

AUTHENTIC PERFORMANCE



In 1995, Neon was the... car performance. In 2002, the... Cruiser re-defined the term "cool"... anticipated Dodge SRT4 knocked the... market back on its heels. Mopar's... game-over upgrades with the latest performance... upgrades, designed to work together to turn your... factory rocket into a street and track monster like no... other. How hard you hit 'em is up to you!

...the... compact... with a powerful... performance... designed to work together to turn your... factory rocket into a street and track monster like no... other. How hard you hit 'em is up to you!

PERFORMANCE



PERFORMANCE CATALOG

# MOPAR PERFORMANCE TERMS AND CONDITIONS



## NOTICE

Federal and many state laws prohibit the removal, modification or rendering inoperative of any part or element of design affecting emissions or safety on motor vehicles used for transporting persons or property on a public street or highway. Violation may result in a fine of up to \$32,500 per vehicle. Mechanical and/or electronic performance parts listed in this catalog with a "1" cannot be used on vehicles used on public streets or highways.

These parts may be used only on vehicles used solely in sanctioned off-highway events. No other applications are intended or implied. Those parts that have been granted an exemption by the California Air Resources Board (CARB) or meet the EPA requirements of memorandum 1A are legal for highway use in California, New York, and Massachusetts and are noted as such.

## NO PARTS WARRANTY – "AS IS"

Mopar Performance parts beginning with a "P" prefix are sold "as is" unless otherwise noted. This means that parts sold by Mopar Performance carry no warranty whatsoever. Implied warranties, such as warranties of merchantability, are excluded. (An implied warranty of merchantability means that the part is reasonably fit for the general purpose for which it was sold). The entire risk as to quality and performance of such parts is with the buyer. Should such parts prove defective following their purchase, the buyer and not the manufacturer, distributor or retailer, assumes the entire cost of all necessary servicing or repair. Chrysler, Jeep®, Dodge and Ram vehicle and parts warranties are voided if the vehicle or parts are used for competition. The addition of performance parts does not by itself void a vehicle's warranty. However, added performance parts (parts not originally supplied on the vehicle from the factory) are not covered by the vehicle's warranty, and any failure that they may cause is also not covered by the vehicle's warranty.

## MOPAR PERFORMANCE CRATE ENGINE 90-DAY LIMITED WARRANTY

Mopar Performance Crate Engine Assemblies not used in competition are warranted for "parts only," AS DELIVERED against defects in materials or workmanship for 90 days from the date of purchase. The following parts, if defective, will be replaced on an exchange basis for 90 days: engine blocks and all internal parts; cylinder head assemblies; intake manifold; core plugs; valve covers; oil pan; timing gear; water pump; gaskets and seals. See your dealer for a copy of the limited warranty, which contains additional terms and limitations.

## MOPAR PARTS 12-MONTH LIMITED WARRANTY

Except parts as listed above, certain parts from Mopar Performance sold over the counter or wholesaled are warranted against defects in workmanship or materials for 12 months/unlimited miles for parts (exchange) only. These parts are identified in this catalog as having a specific part number structure. Part numbers starting with "P" are not covered under the 12-month warranty. Other parts listed in this catalog without a "P" prefix part number are covered under the 12-Month Limited Warranty described here. See your dealer for a copy of the limited warranty, which contains additional terms and limitations. Parts installed on a Chrysler, Plymouth, Jeep®, Dodge and Ram vehicle by an authorized Chrysler, Jeep®, Dodge and Ram dealer are warranted for 12 months/unlimited miles for parts (exchange) only. See your dealer for a copy of the limited warranty, which contains additional terms and limitations.

## **EMISSIONS STATEMENT**

Federal law requires emissions parts on new vehicles to be warranted for at least two years or 24,000 miles, whichever comes first. Federal and many state laws also prohibit the removal, modification or rendering inoperative any part that affects emissions or safety on motor vehicles used on public streets or highways. Many Mopar Performance parts are designated for track use or off-road use only. Installation of certain components may bring the vehicle out of compliance with safety and/or emissions standards. Mopar recommends that vehicles with parts designated in this fashion not be operated on public roads. Mopar Performance customers are responsible for complying with applicable state and local environmental regulations. Additionally, certain performance parts may affect the emissions characteristics of the vehicle. If you install them on the vehicle, and your vehicle consequently fails a required state or local I/M (inspection and maintenance) emissions test, including any test required to maintain or renew your vehicle's registration, or if your vehicle is subject to an emissions recall, Chrysler Group LLC may not be required to repair your vehicle under the emissions performance warranty, and you may be required to remove those parts at your own expense in order to obtain repairs necessary to pass the I/M test or to perform the recall.

## **NOTE — CALIFORNIA ONLY**

The emissions laws and regulations of the state of California apply to all non-racing vehicles operated in California. Consequently, those parts marked in this catalog with a "1" and appropriately marked on their packaging may legally be used in California only on a racing vehicle that will never be operated on public roads.

## **PARTS ORDERING AND INQUIRIES**

The parts in this catalog may be ordered from authorized Chrysler, Jeep®, Dodge and Ram dealerships or the speed shops carrying the Mopar Performance line of products. When a part ordered has been superseded, the replacing part will be shipped automatically. The price of the replacing part may differ from the ordered part. All products, illustrations and specifications are based upon current information at the time of publication approval. Although descriptions are believed correct, complete accuracy cannot be guaranteed. Chrysler Group LLC reserves the right to make changes at any time, without notice or obligation, to the information contained in this printed document, including and without limitation to prices, specifications, equipment, colors, materials, and to change or discontinue products.

# TABLE OF CONTENTS

## ENGINES ..... 10

<b>Hemi® , Gen III</b> .....	<b>10</b>
Crate Engines .....	10
Blocks .....	10
Engine Block Hardware .....	11
Crankshafts and Hardware .....	12
Vibration Dampers .....	12
Pistons and Connecting Rods .....	12
Camshafts, Lifters, and Hardware .....	12
Cylinder Heads, Gaskets, and Hardware .....	13
Valve Covers and Hardware .....	14
Intake Manifolds, Hardware, and Gaskets .....	14
Carburetors and Hardware .....	15
Ignition and Electronics .....	15
Oiling Components .....	17
Transmission and Drivetrain .....	17
Rocker Arms, Shafts, Supports, and Hardware .....	19
<b>Hemi® , Gen II</b> .....	<b>22</b>
Crate Engines .....	22
Blocks .....	24
Engine Installation Components .....	25
Engine Block Hardware .....	25
Crankshafts and Hardware .....	26
Vibration Dampers .....	26
Timing Chain and Sprockets .....	27
Pistons and Connecting Rods .....	27
Camshafts, Lifters, and Hardware .....	28
Cylinder Heads, Gaskets, and Hardware .....	29
Valve Covers and Hardware .....	30
Valves and Valve Train Hardware .....	32
Rocker Arms, Shafts, Supports, and Hardware .....	34
Intake Manifolds, Hardware, and Gaskets .....	35
Oiling Components .....	37
Cooling Systems .....	39
<b>Big Block</b> .....	<b>42</b>
Blocks .....	42
Engine Block Hardware .....	42
Crankshafts and Hardware .....	42
Vibration Dampers .....	43
Timing Chain and Sprockets .....	43
Camshafts, Lifters, and Hardware .....	44
Cylinder Heads, Gaskets, and Hardware .....	50
Valve Covers and Hardware .....	51
Valves and Valve Train Hardware .....	53

Rocker Arms, Shafts, Supports, and Hardware .....	54
Intake Manifolds, Hardware, and Gaskets .....	56
Oiling Components .....	57
Cooling Systems .....	60
<b>Small Block</b> .....	<b>64</b>
Crate Engines .....	64
Blocks .....	66
Engine Block Hardware .....	69
Crankshafts and Hardware .....	69
Vibration Dampers .....	70
Timing Chain and Sprockets .....	71
Camshafts, Lifters, and Hardware .....	74
Cylinder Heads, Gaskets, and Hardware .....	78
Valve Covers and Hardware .....	82
Valves and Valve Train Hardware .....	85
Rocker Arms, Shafts, Supports, and Hardware .....	87
Intake Manifolds, Hardware, and Gaskets .....	90
Oiling Components .....	93
Cooling Systems .....	95

## RESTORATION ..... 100

<b>Fuel Systems</b> .....	<b>100</b>
Carburetors and Hardware .....	100
Fuel Pumps and Hardware .....	101
Vapor Separator .....	102
Six Pack Induction Systems .....	102
Air Systems .....	104
Fuel Injection .....	106
<b>Ignition and Electronics</b> .....	<b>108</b>
Distributors and Hardware .....	108
Electronic Ignition Systems .....	109
Ballast Resistors .....	110
Ignition Wires and Spark Plugs .....	111
Coils .....	112
Starters .....	113
Voltage Regulators .....	113
Ignition and Electronics .....	114
Alternators .....	114
<b>Automatic Transmission</b> .....	<b>116</b>
Flex Plates and Hardware .....	116
Shifters and Shift Improvement Kits .....	116
Automatic Transmission Components .....	116
Transmission Overhaul Kits .....	118
Transmission Pans and Hardware .....	119

# TABLE OF CONTENTS

Torque Converters and Hardware . . . . .	119
<b>Manual Transmission . . . . .</b>	<b>122</b>
Flywheels and Hardware . . . . .	122
Bell Housing . . . . .	123
Clutch Discs, Pressure Plates and Hardware . . . . .	123
Shifters and Shift Improvement Kits . . . . .	125
<b>Drivetrain and Rear Axle Components . . . . .</b>	<b>128</b>
Universal Joint and Yoke Kits . . . . .	128
Rear Axle Components . . . . .	129
Differential Components . . . . .	130
<b>Steering, Suspension, and Brakes . . . . .</b>	<b>132</b>
Leaf Springs and Hardware . . . . .	132
Frame Components . . . . .	135
Torsion Bars and Hardware . . . . .	135
Suspension Seals and Bushings . . . . .	135
Manual Steering Hardware . . . . .	136
Shocks and Struts . . . . .	136
Brakes . . . . .	136
<b>Interior/Body . . . . .</b>	<b>140</b>
Underhood . . . . .	140
Interior . . . . .	145
Grilles and Headlamp Bezels . . . . .	147
Hoods and Hood Components . . . . .	148
Handles . . . . .	149
Mirrors . . . . .	150
Trunk . . . . .	151
Racks . . . . .	151
Bumpers/ Bumperettes . . . . .	151
Lamps and Lenses . . . . .	151
Sheetmetal . . . . .	153
Wheelhouse . . . . .	154
Valence . . . . .	154
Emblems and Decals . . . . .	155
Wheel Components . . . . .	158

## **CHRYSLER/DODGE . . . . . 164**

<b>Viper . . . . .</b>	<b>164</b>
Brakes . . . . .	164
Viper SRT10 Power Kit . . . . .	164
Valves and Valve Train Hardware . . . . .	165
Ignition and Electronics . . . . .	165
Cooling Systems . . . . .	166
Differential Components . . . . .	167

Transmission Components . . . . .	168
Suspension Upgrades and Components . . . . .	169
Air Systems . . . . .	170
Exhaust Systems . . . . .	171
GTS-R Engine Parts . . . . .	171
Exterior Body Components . . . . .	173
<b>Eight-Cylinder Late Model Vehicles . . . . .</b>	<b>176</b>
Electronic Control Modules . . . . .	176
Air Systems . . . . .	176
Exhaust Systems . . . . .	177
Exterior Body Components . . . . .	179
Interior . . . . .	180
Suspension Upgrades and Components . . . . .	180
Drivetrain and Rear Axle Components . . . . .	181
<b>Four- and Six-Cylinder Late Model Vehicles . . . . .</b>	<b>184</b>
Turbo Service Parts . . . . .	184
Camshafts, Lifters, and Hardware . . . . .	185
Rocker Arms, Shafts, Supports, and Hardware . . . . .	186
Cylinder Heads, Gaskets, and Hardware . . . . .	186
Engine Struts and Mounts . . . . .	186
Pistons and Connecting Rods . . . . .	186
Intake Manifolds, Hardware, and Gaskets . . . . .	187
Valve Train Hardware and Components . . . . .	187
Valve Covers and Hardware . . . . .	188
Suspension Upgrades and Components . . . . .	188
Ignition and Electronics . . . . .	192
Air Systems . . . . .	194
Oiling Components . . . . .	195
Exhaust Systems . . . . .	196
Transaxle Components . . . . .	197
Wheel Components . . . . .	197
Exterior Body Components . . . . .	198
Brakes . . . . .	198
Bearing . . . . .	198

## **RACING . . . . . 202**

<b>Drag Racing . . . . .</b>	<b>202</b>
LC22R Challenger Drag Pak Service Parts . . . . .	202
Blocks . . . . .	203
Gear Drives and Service Parts . . . . .	207
Crankshafts and Hardware . . . . .	207
Cylinder Heads, Gaskets, and Hardware . . . . .	207
Valve Covers and Hardware . . . . .	208
Hemi Pro Stock . . . . .	208
Race Bodies . . . . .	208

# TABLE OF CONTENTS

<b>Sprint Car / Midget / Dirt Late Model</b> .....	<b>212</b>
Blocks .....	212
Engine Block Hardware .....	212
Cylinder Heads, Gaskets, and Hardware .....	213
Intake Manifolds, Hardware, and Gaskets .....	214
Valve Covers .....	214
Camshafts, Lifters, and Hardware .....	215
Rocker Arms, Shafts, Supports, and Hardware .....	215
Crankshafts and Hardware .....	215
Gear Drives and Service Parts .....	216
Oiling Components .....	217
Books .....	217
<b>NASCAR® / Late Model</b> .....	<b>220</b>
Blocks .....	220
Engine Block Hardware .....	220
Crankshafts and Hardware .....	221
Camshafts, Lifters, and Hardware .....	221
Cylinder Heads, Gaskets, and Hardware .....	221
Exhaust Systems .....	223
Valve Covers and Hardware .....	223
Oil, Fuel, and Water Pumps .....	223
NASCAR .....	223
Books .....	224

## **JEEP/RAM** .....

**230**

<b>Jeep/Ram</b> .....	<b>230</b>
Blocks .....	230
Engine Block Hardware .....	230
Timing Chain and Sprockets .....	230
Vibration Dampers .....	230
Camshafts, Lifters, and Hardware .....	231
Cylinder Heads, Gaskets, and Hardware .....	231
Rocker Arms, Shafts, Supports, and Hardware .....	232
Valve Covers and Hardware .....	232
Valves and Valve Train Hardware .....	232
Intake Manifolds, Hardware, and Gaskets .....	233
Air Systems .....	234
Exhaust Systems .....	238
Oiling Components .....	241
Suspension Upgrades and Components .....	242
Ignition and Electronics .....	252
Automatic Transmission Components .....	253
Transmission/Transfer Cases .....	254
Drivetrain and Rear Axle Components .....	255
Axle Components .....	256

Exterior Body Components .....	257
Hoods and Hood Components .....	258
Off Road Tools and Accessories .....	258

## **MISCELLANEOUS** .....

**262**

<b>Performance Gauges</b> .....	<b>262</b>
Gauges .....	262
Gauge Pods .....	270
Gauge Components .....	270
<b>SilverStar Lighting</b> .....	<b>274</b>
Lamps .....	274
<b>Merchandise</b> .....	<b>278</b>
Diecast .....	278
Posters .....	280
Books .....	281
Fender Covers .....	282
Wheel Covers .....	282
Decals .....	283

## MOPAR® ENGINES: Fast and Furious

Whether you're into the gargantuan crates that powered an entire era, the HEMI® that spawned a revolution, or the finely-tuned small blocks that harness every drop of fuel, you'll find the engines you need on the pages that follow. Drop one in and let everyone else play catch-up.

PERFORMANCE







# HEMI® GEN III .01

6.1L - 426 - 5.7L



PERFORMANCE

## HEMI®, GEN III

### CRATE ENGINES

#### A. 426 Hemi Crate Engine, 540 Horsepower

Mopar's newest crate engine pays homage to its legendary roots in this all new aluminum Gen III Hemi. At 540 horsepower and 530 ft.-lbs. of torque (SAE J1349), this Hemi is a real beast.

##### Features:

- 426 cubic-inches in a HEMI Gen III Siamese-Bore Block (P5155507)
- All Aluminum Cylinder Heads and Engine Block (4.0" Stroke X 4.125" Bore)
- Over 500 Horsepower and 500 lb-ft Torque
- Forged Crankshaft, Connecting Rods and Pistons
- 8620 HR billet steel main caps with 6-bolt (# 2/3/4) and 4-bolt (# 1/5) caps to beef-up the bottom end for severe performance applications
- All HEMI Gen III dress items fit (front cover, oil pan, oil filter mounting, Front End Accessory Drive (FEAD) etc.)
- Includes attachments for a front motor plate

<sup>1</sup> P5155513 Crate Engine, 426 Hemi, Aluminum, Gen III, 540 Horsepower, 530 ft.-lbs. Torque

#### B. 6.1L Hemi Crate Engine - 425 Horsepower

These cast iron 6.1L Hemi engines deliver horsepower and torque right out of the crate. P5155437 includes factory wire harness and throttle body. P5155067 includes billet fuel rails and integral pressure gauge (P5153783), cable operated 80 mm throttle body (P5153689), and programmable EMS kit (P5155067). Dyno tested and ready to run.

<sup>1</sup> P5155067 Crate Engine, 6.1L Hemi, EFI, 425 Horsepower, 420 ft.-lbs. Torque. Includes billet fuel rail with integral pressure regulator (P5153783), cable operated 80mm throttle body (P5153689), and programmable EMS kit (P5153921). Dyno tested, ready to run.

<sup>1</sup> P5155437 Crate Engine, 6.1L Hemi, No EMS, 425 Horsepower, 420 ft.-lbs. Torque

#### C. 5.7L Eagle Crate Engine, 372 Horsepower

The 5.7-liter HEMI® V8 available with Multi-Displacement System (MDS) delivers:

- Variable Cam Timing, bringing more power and optimal performance
- Greater efficiency when equipped with MDS
- Dual ignition (two spark plugs per cylinder) to increase peak power and torque

<sup>1</sup> P5155459 Crate Engine, 5.7L Eagle, 372 Horsepower, 400 ft.-lbs. Torque

### BLOCKS

#### D. Short Blocks

<sup>1</sup> P5155003 Block, Cast Iron, Short, 392 Hemi. Includes Performance Crankshaft, Pistons, Rods, and Rod Bearings.

<sup>1</sup> P5155038 Block, Cast Iron, Short, 6.1L Hemi. Includes Performance Pistons, Rods, and Rod Bearings.



A.



B.



C.



D.



A.

## BLOCKS

### A. Blocks- Aluminum

Hemi Gen III Aluminum Blocks are 100 pounds lighter than 6.1L production cast iron blocks! They are designed to accommodate all parts from a 6.1L Hemi Gen III engine.

#### Features:

- Lightweight aluminum gives added performance in more ways than one - better acceleration, braking, vehicle dynamics, weight distribution, you name it. Lighter is better.
- Water jackets have been completely re-designed to accommodate a Siamese bore. Extensive Computational Fluid Dynamics (CFD) studies have been performed to balance thermal conditions for consistent and reliable performance.
- Crankcase clearance designed for a 4.125" stroke crankshaft. A 4.250" stroke will fit with machining around the oil drain backs.
- The main bearing supports and the bottom end of the block have been completely redesigned for the additional strength required for a forced induction 440+ cubic inch motor.
- 8620 HR billet steel main caps with four-bolt center caps beef-up the bottom end for severe performance applications.
- Capable of supporting a dry sump package for reduced windage and to allow more engine installation options, including lower vehicle center of gravity.
- Camshaft bearing support area increased to permit the use of a 60 mm roller bearing, if desired.
- Lifter bores can be opened to 1.060" for a bushed-style lifter.
- Additional boss in the front timing chain area for an idler (double roller chain). Additional boss for a front gear drive, plus attachments for a front motor plate.
- All HEMI Gen III dress items fit Gen III Aluminum Blocks (front cover, oil pan, oil filter mounting, Front End Accessory Drive (FEAD), etc.)

- <sup>1</sup> **P5155507** Block, Aluminum, 426 Hemi, Gen III, Bored at 4.125", Can Be Bored Up to 4.155"
- <sup>1</sup> **P5153897** Block, Aluminum, 6.1L Hemi, Finished Bored at 4.055"
- <sup>1</sup> **P5153898** Block, Aluminum, 6.1L Hemi, Semi-Finished Bored at 4.114". Can be Bored Up to 4.185"
- <sup>1</sup> **P5155630** Block, Aluminum, Hemi Gen III, Semi Finished Builder's Special

## ENGINE BLOCK HARDWARE

### Girdles (Not Shown)

Adds bottom end strength to Hemi Gen III aluminum engine blocks. Designed for modified, high performance engine builds. Note that the block must be modified for clearance. Cannot be used with stock windage tray. Requires fabricated oil pan and pickup tube.

- P5155532** Girdle, Engine Block, 6.1L Hemi

# HEMI®, GEN III

## CRANKSHAFTS AND HARDWARE

### A. Forged Steel Crankshaft

High-strength premium quality 4140 forged steel crankshaft machined from proprietary forgings. For use in high-performance and race applications. Crank nose is machined for full-length damper key and features 2.100" rod throws and "new Hemi" eight-bolt flange - 3.795" Stroke. For 6.1L Hemi block-based stroker applications.

<sup>1</sup> P5153578 Crankshaft, 4140 Forged Steel, 3.795" Stroke, 2.100" Rod Journals, 392 Hemi Crate Engine

### Crankshaft Trigger Wheel Kit (Not Shown)

P5155041 Crankshaft Trigger Wheel, includes Fasteners, 6.1L/392 Hemi. Does Not Fit 5.7L Crankshafts.



## VIBRATION DAMPERS

### B. Vibration Dampers

ATI Super Damper, SFI-approved for street and race applications. Built specifically for high-performance applications, the ATI Super Damper provides balanced dampening of torsional crankshaft vibrations at all RPM. Comes with 360-degree, laser-etched timing marks. 5% O.D.

<sup>1</sup> P5153630 Damper, Crank, SFI, 5.7L / 6.1L / 392 Hemi, Car/Jeep Timing Cover

<sup>1</sup> P5153631 Damper, Crank, SFI, 5.7L Hemi, Truck Timing Cover

A.

B. P5153630

## PISTONS AND CONNECTING RODS

### C. Pistons

Features intake valve notch and 10.5:1 compression ratio.

<sup>1</sup> P5153635 Piston, Forged Aluminum, Designed for production 4.055" bore and 3.795" stroke. Uses full floating 0.927" pin. 10.5:1 compression ratio. Uses stock piston rings. 6.1L/392 Hemi Engine Set.

### D. Connecting Rod Bolt Kit

P5153480 Bolt Kit, Connecting Rod, 5.7L Hemi



## CAMSHAFTS, LIFTERS, AND HARDWARE

### E. Camshaft, 392 Hemi

Developed exclusively for the Mopar 392 Hemi Crate Engine to provide the best combination of power, torque and reliability. This hydraulic roller camshaft is designed to work with production 6.1L engine block and hydraulic roller lifters (not included), performance valve springs and pushrods. Valve notches will be required for proper valve-to-piston clearance (.080" minimum intake, .100" minimum exhaust). Stock pistons are NOT recommended.

<sup>1</sup> P5153691 Camshaft, Duration @ .006" 279 degrees intake / 285 degrees exhaust. Lobe spread 110, Gross lift with stock rockers .584 inch intake/ .552 inch exhaust, 392 Hemi Crate Engine

B. P5153631

C. P5153635



D.

E.

## CAMSHAFTS, LIFTERS, AND HARDWARE

## A. Camshaft, 5.7L Hemi

This 5.7L Hemi Mopar Performance camshaft was designed applying the same technology utilized on NASCAR racing engines as a drop-in replacement for the stock cam. It will increase airflow and engine output at 3,000 rpm and above while maintaining low rpm drivability characteristics. Requires non-MDS hydraulic lifters. Recommended springs: 5.7L Hemi production springs.

<sup>1</sup> **P5153325AB** Camshaft, Duration @ .006" 259 degrees intake, 267 degrees exhaust. Duration @ .050" 204 degrees intake / 210.5 degrees exhaust. Lobe spread 116 degrees. Gross lift with stock rockers .500 inch intake, .488 inch exhaust, 5.7L Hemi

## B. Camshaft and Lifters Kit, 5.7L Hemi

Includes 5.7L Hemi Mopar Performance Camshaft (P5153325AB) and non-MDS hydraulic lifters. (16 total)

<sup>1</sup> **P5153570AB** Camshaft, with Non MDS Style Lifters, 5.7L Hemi

## C. Pushrod Set

Competition chrome moly steel Pushrod set features 6.625" and 7.875" length, 5/16" diameter.

<sup>1</sup> **P5153629** Pushrod, Chrome Moly Steel, 0.080" Wall, 6.625" and 7.875" Length, 5/16" Diameter, 5.7L/6.1L/392 Hemi, Engine Set

## CYLINDER HEADS, GASKETS, AND HARDWARE

## D. Cylinder Heads- CNC Ported

These bolt-on, CNC-ported Cylinder Heads are equipped with the highest quality parts and technology available to deliver optimum performance. Capable of handling camshafts with valve lifts up to .600", they are designed to optimize flow while maintaining optimum port velocity. 2.100" intake valve, 1.600" exhaust valve. 5.7L: 2.055" intake valve, 1.600" exhaust valve.

## Specifications:

- Brand-new, factory-fresh castings (no core required)
- Five-axis, CNC-ported
- Ovate wire, "beehive" competition valve springs
- One-piece stainless steel intake and exhaust valves
- Titanium, 7° valve spring retainers
- Machined, 7° round groove valve locks
- High-temperature Viton valve seals, bronze alloy valve guides
- Hardened, custom valve seats
- Premium "five-angle" CNC-machined valve job

<sup>1</sup> **P5153345** Cylinder Head, CNC-Ported, Bare, LH, 5.7L Hemi

<sup>1</sup> **P5153346** Cylinder Head, CNC-Ported, Bare, RH, 5.7L Hemi

<sup>1</sup> **P5153343** Cylinder Head, CNC-Ported, Asm., LH, 5.7L Hemi

<sup>1</sup> **P5153344** Cylinder Head, CNC-Ported, Asm., RH, 5.7L Hemi



A.



B.



C.



D.

Questions? Call the Mopar Direct Connection Techline at 1-888-528-HEMI (4364)

<sup>1</sup> Not legal on pollution-controlled vehicles or vehicles registered for highway use.

## HEMI®, GEN III

### CYLINDER HEADS, GASKETS, AND HARDWARE

#### Cylinder Head Hardware (Not Shown)

P5155517 Hardware Kit, Stud Set, Cylinder Head, 6.1L Hemi

### VALVE COVERS AND HARDWARE

#### A. Valve Covers, 5.7L Hemi

These Valve Covers feature a Permarstar™ chrome finish. A perfect way to dress up any 5.7L Hemi engine. They will not discolor under heat. Set includes two valve covers, valve cover gaskets and spark plug seals.

P4510845 Valve Covers, Permarstar Chrome, Up to 2005, 5.7L Hemi Crate Engine, Production 5.7L Engines

#### Valve Covers, 5.7L/6.1L Hemi (Not Shown)

P5155524 Valve Cover, Billet Aluminum, 5.7L / 6.1L Hemi

#### Breathers (Not Shown)

P5155631 Breather, Billet Aluminum, 5.7L / 6.1L Hemi

### INTAKE MANIFOLDS, HARDWARE, AND GASKETS

#### B. Single Plane Intake Manifold

5.7L Crate Engine Single Plane Intake Manifolds - both Carburetor and EFI versions. EFI version is machined to accept injectors and MAP sensor. Both are drilled with the standard Holley pattern.

<sup>1</sup> P4510581AB Intake Manifold, Aluminum, Single Plane, 5.7L Carbureted Engine

<sup>1</sup> P4510582AB Intake Manifold, Aluminum, Single Plane, 5.7L EFI Engine

#### C. Dual Plane Intake Manifold

This Dual Plane Mid-Riser Intake Manifold can accept two Edelbrock or AFB-style carburetors.

<sup>1</sup> P5153556 Intake Manifold, Aluminum, Dual Plane, Dual Quad, Accepts AFB / AVS Style Carburetors. Use with Carburetor and Linkage Kit P5153904, 5.7L Hemi (2003-2008)

<sup>1</sup> P5155462 Intake Manifold, Aluminum, Stock, 6.1L Hemi

#### D. PCV Valve Adapter

Complete kit to install a PCV system to an intake manifold. Kit includes PCV valve, hose, related clamps and fittings plus makeup air filter and oil fill cap. Use with carbureted intake manifolds P4510812, P5153633, and P5153634.

<sup>1</sup> P5155005 PCV Adapter Kit, 5.7L/6.1L/392 Intake Manifolds



A.



B. P4510582



C. P5153556



D. P5155005

## INTAKE MANIFOLDS, HARDWARE, AND GASKETS

### Intake Manifold Gaskets (Not Shown)

- <sup>1</sup> P5153757 Gasket, Intake Manifold, 5.7L Hemi, Set
- <sup>1</sup> P5153758 Gasket, Intake Manifold, 5.7L/6.1L, Set, Drag Pak



## CARBURETORS AND HARDWARE

### A. Holley 600 CFM Carburetor

- <sup>1</sup> P4510358 Carburetor, Holley 600 cfm, 5.7L Hemi Crate Engine

## IGNITION AND ELECTRONICS

### B. EMS, Programmable

"Plug and Play" Engine Management Systems (EMS)  
 These engine management systems will forever change the way you look at and perform fuel injection tuning! User-friendly Windows™ based software (XP, 2000, NT, 98, 95 and ME) makes the task of copying, viewing and manipulating data as simple as a click of the mouse. User-defined templates are easily configurable and enable tuners to establish "quick keys" to any pertinent information during the tuning process. The infinitely adjustable Mopar EMS software allows tuners to program virtually any combination of engine control, power adders and auxiliary devices, and accurately deliver proper amounts of fuel and correct ignition timing for virtually any engine configuration or operating condition. Mopar's programmable engine management system is capable of adapting to almost any vehicle using "flying lead" wiring harness (available separately). We are confident that this is the most versatile, powerful, and comprehensive universal engine management program available for your Mopar!

Unique features found in Mopar's universal EMS also include independent, built-in "peak and hold" injector drivers, capable of controlling both high and low impedance injectors of any brand or flow rate. Direct ignition coil drivers control the coil-on-plug system with no additional hardware required. Unique, dual-UEGO (wideband O<sub>2</sub> sensor) input provides accurate A/F tuning and calibration capabilities no matter how heavily modified the engine. In addition, dual-channel (typically, one per cylinder bank) detonation (spark knock) sensor capability provides safe engine operation under a wide range of loads, altitudes, and fuel octane availability.

- <sup>1</sup> P5153608 EMS, Programmable, Carbureted Applications
- <sup>1</sup> P5153528 EMS, Programmable, EFI Applications

Note: For crate engine or conversion of 5.7L or 6.1L into an older classic car or truck. Not designed for newer vehicles already equipped with a 5.7L or 6.1L Hemi.

**IMPORTANT NOTICE:** This device is not legal for use on pollution-controlled vehicles certified for use on streets or highways. Once this device is installed, use of the vehicle on a street or highway is a violation of the Clean Air Act, potentially subjecting the operator and the installer to civil penalties of up to \$32,500 per vehicle depending on the circumstances.

A.

---



B.

---

Questions? Call the Mopar Direct Connection Techline at 1-888-528-HEMI (4364)

<sup>1</sup> Not legal on pollution-controlled vehicles or vehicles registered for highway use.

## IGNITION AND ELECTRONICS

### A. Engine Wiring Harness- Programmable

Mopar Performance stand-alone engine harnesses are designed to provide everything you need to properly wire your car in one simple configuration. Each master wiring harness includes built-in fuses and relays for fans, pumps, auxiliary power, and more. Harness has bundle identifiers for easy identification and installation to production Mopar sensors. Secure, "bolt-in" plug mates to Mopar EMS controller and eliminates any chance of separation. Each harness incorporates flyinglead UEGO branches, allowing custom positioning of both left and right UEGO sensors.

- <sup>1</sup> P5153607AB Wiring Harness, Programmable, for use with 392 / 6.1L / 5.7L Hemi with Carbureted Intake, 2006-up Coils
- <sup>1</sup> P5153530AB Wiring Harness, Programmable, for use with 392 / 6.1L / 5.7L Hemi with Production Intake and Manual Single Blade Throttle Body (P5153689) and 2006-up Coils. (5.7L Truck Manifold May Require Wire Length Modification)
- <sup>1</sup> P5153606AB Wiring Harness, Programmable, for use with 5.7L Hemi with Carbureted Intake and 2003-05 Coils
- <sup>1</sup> P5155529AB Wiring Harness, Programmable, for use with 5.7L Hemi, with Four-Barrel Throttle Body (P4510363) and Four-barrel EFI Intake (P4510582) and 2003-05 Coils.

### B. EMS, Programmable, Kits

The EMS Programmable Kits combine Mopar's programmable Engine Management System with a stand-alone engine harness.

- <sup>1</sup> P5153920 EMS Kit, Programmable, with Control Unit and Harness, for use with 392/6.1L/5.7L Hemi with Carbureted Intake and 2006 and newer Coils. Contains P5153607AB and P5153608
- <sup>1</sup> P5153916 EMS Kit, Programmable, with Control Unit and Harness, for use with 5.7L Hemi with Carbureted Intake and 2003-05 Coils. Contains P5153606AB and P5153608
- <sup>1</sup> P5153917 EMS Kit, Programmable, with Control Unit and Harness, for use with 5.7L Hemi with four-barrel Throttle Body (P4510363) and four-barrel EFI Intake (P4510582) and 2003-05 Coils. Contains P5155529AB and P5153528
- <sup>1</sup> P5153921 EMS Kit, Programmable, with Control Unit and Harness, for use with 6.1L/392 EFI Kit. Contains P5153530AB and P5153528.

**IMPORTANT NOTICE:** This device is not legal for use on pollution-controlled vehicles certified for use on streets or highways. Once this device is installed, use of the vehicle on a street or highway is a violation of the Clean Air Act, potentially subjecting the operator and the installer to civil penalties of up to \$32,500 per vehicle depending on the circumstances.

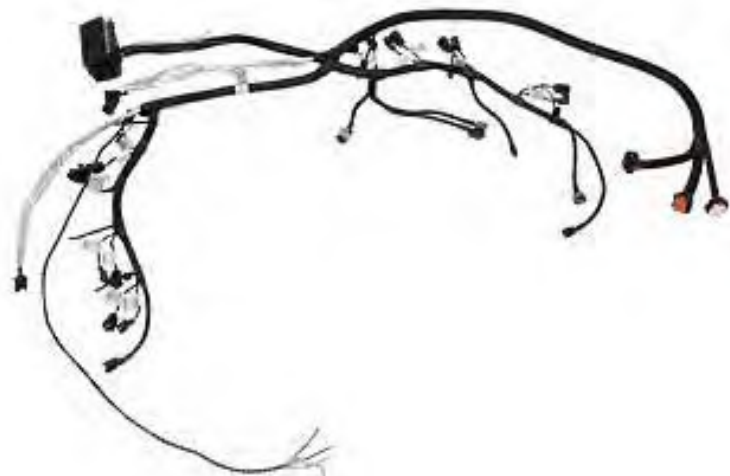

A.

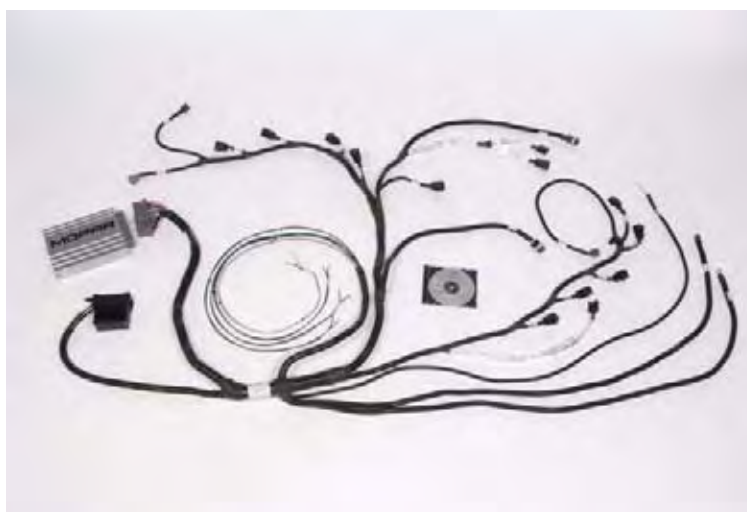

B. P5153916





A. P4510816



B. P5153783



B. P5155068



B. P5155065



B. P5153730



C. P5153437



D.

## IGNITION AND ELECTRONICS

### A. EMS, Non-Programmable

Service part for 5.7L Hemi Crate Engine. Non-programmable.

- <sup>1</sup> P4510816 EMS, Non-Programmable, Carbureted, 5.7L Hemi Engine
- <sup>1</sup> P4510342 EMS, Non-Programmable, EFI, 5.7L Hemi Engine
- <sup>1</sup> P4510357 Wiring Harness, Non Programmable, for use with 5.7L Hemi with Carbureted Intake and 2003-05 Coils
- <sup>1</sup> P4510356 Wiring Harness, Non Programmable, for use with 5.7L Hemi with Four-barrel Throttle Body (P4510363) and Four-barrel EFI Intake (P4510582), 2003-05 Coils

**IMPORTANT NOTICE:** This device is not legal for use on pollution-controlled vehicles certified for use on streets or highways. Once this device is installed, use of the vehicle on a street or highway is a violation of the Clean Air Act, potentially subjecting the operator and the installer to civil penalties of up to \$32,500 per vehicle depending on the circumstances.

### B. EMS, Accessories

- 04606487AB ACT Sensor, For Use With Hemi Applications
- <sup>1</sup> P5153783 Fuel Rail, Billet Aluminum, 5.7L/6.1L/392 Hemi
- <sup>1</sup> P5155068 Hall Effect EMS & Electric Speedometer Sender. Sixteen pulse per revolution. Hall effect sender. 7/8-18 thread. .104 x .104 square drive key, with mechanical pass through for cruise control.
- 04861552AC IAC Motor, For Use With Hemi Applications
- 56041018AD MAP Sensor, For Use With Hemi Applications
- P5155065 Pin Connector Kit (5 pre-terminated wires) for adding inputs/outputs to the Mopar Programmable EMS Units
- 05017479AA TPS, For Use With Hemi Applications
- <sup>1</sup> P5153730 UEGO Sensor, Wideband, Use with Mopar Programmable EMS Systems and Crate Engines

## OILING COMPONENTS

### C. Oiler Filler Neck

- P5153437 Oil Fill Assembly with Cap, High Rise, For Use With 5.7/6.1L High Rise Intake Manifold (P4510813AB)

## TRANSMISSION AND DRIVETRAIN

### D. Torque Converters

- <sup>1</sup> P5153726 Torque Converter, Performance 175K, 2004-08 Charger/300/ Magnum/ Challenger, 5.7L/6.1L

HEMI®, GEN III

## TRANSMISSION AND DRIVETRAIN

### A. Flywheel- Steel

Use this 130-tooth, 30-pound Steel Flywheel if you need extra rotating mass to launch the car off the line. Also great for street applications where drivability and heavy-duty applications are required. Accepts 10.5" Mopar Race, Muscle, or Street/Strip diaphragm Clutch Cover (P5153595 recommended). Use with Mopar Small Block Lightweight Starter P5249644AB, SFI Bell Housing P5153602.

<sup>1</sup> P5153592 Flywheel, Steel, 392/ 6.1L/ 5.7L

Note: Not to be used as an OEM replacement for production 5.7L/6.1L flywheels.

### B. Flywheel- Aluminum

Use this 130-tooth, 14.5-pound aluminum flywheel with any 5.7L/6.1L Hemi engine to reduce rotating mass and inertia, and gain quicker engine acceleration. Flywheel has a steel serviceable friction surface. Accepts 10.5" Mopar Race, Muscle or Street/Strip Diaphragm Clutch Covers (P5153595 recommended). Use Mopar Small Block Starter P5249644AB, SFI Bell Housing P5153602.

<sup>1</sup> P5153593 Flywheel, Aluminum, 392/6.1L/ 5.7L Hemi

Note: Not to be used as an OEM replacement for production 5.7L/6.1L flywheels.

### C. Bell Housing, SFI

This hydroformed SFI Bell Housing can be used with A-833 four-speed or Tremec TKO transmissions. Both hydraulic and mechanical Mopar clutch linkage systems can be used, either with the stock "Z-bar" design, or the hydraulic clutch components listed below. Comes with the bell housing, backing plate, all fasteners, pivot ball and pilot bearing.

P5153602 Bell Housing, SFI, 5.7L/6.1L Hemi, All Magnum (carb) and LA Small Block Engines

52107555 Clutch Fork

52107625 Clutch Master/Slave Assembly

52087542 Pivot Ball

53008342 Release Bearing

04338855 Spring, Clutch Release Fork

Note: Some modifications will be necessary to adapt a hydraulic system to your vehicle.

### D. Diaphragm Clutch Cover

This 10.5" Diaphragm Clutch Cover is capable of 2,850 psi clamp load, 430-445 psi finger pressure. Provides better modulation and pedal feel. Compatible with most Mopar clutch release bearings that have a flat face. Use with Flywheel P5153592 and P5153593 for 5.7L/6.1L conversion.

P5153595 Diaphragm Clutch Cover



A.



B.



C.



D.



A.

## TRANSMISSION AND DRIVETRAIN

### A. Clutch Plate, Hemi Conversion

Use this special Conversion Clutch Plate when putting a five-speed or six-speed Tremec transmission behind your 5.7L/6.1L Hemi crate engine. Sprung hub for smoother engagement (1-1/8-inch 26-spline hub). Constructed of organic material; capable of 500 ft.-lbs. torque.

**P5153594** Clutch Plate, Conversion, 5.7L/6.1L Hemi

### Flex Plates (Not Shown)

<sup>1</sup> **P5155427** Flex Plate, RWD, Butterfly, 727/904 Transmissions, No Ring Gear, Requires Converters with Integral Ring Gears, Drilled for Both Patterns Even, and Offset, 5.7/ 6.1/ 392 Hemi, 5/16" Bolts

<sup>1</sup> **P5153753** Flex Plate, SFI-approved for use to adapt 727/904 type automatic transmissions to the new 5.7L, 6.1L and 392 Hemi blocks, 7/16" Bolts

## ROCKER ARMS, SHAFTS, SUPPORTS, AND HARDWARE

### B. Tie Bar

Tie Bars are intended to increase the stiffness of the rocker shaft attachment to the cylinder head. Tie Bars also help enhance cylinder head durability and valve train stability when running the increased RPM and load required by motorsport applications. They are designed to work with current production rocker shaft assemblies and attaching fasteners. Note that when used with production plastic valve covers, the covers will require a slight clearance notch to be added at each end.

**P5155654** Tie Bar, 2005-08 5.7L Hemi, 2005-10 6.1L Hemi

**P5155655** Tie Bar, 2009-10 5.7L Eagle, 2011 6.4L



B. P5155654 (Cylinder Head Not Included)



B. P5155654

Questions? Call the Mopar Direct Connection Techline at 1-888-528-HEMI (4364)

<sup>1</sup> Not legal on pollution-controlled vehicles or vehicles registered for highway use.



# HEMI® GEN II .02

572 - 528 - 472 - 426



## HEMI®, GEN II

### CRATE ENGINES

#### A. 572 Hemi Crate Engine, 650 Horsepower

There is no substitute for displacement! The largest of Mopar's Gen II line up this giant 572-cid Hemi is rated at 650 horsepower and 660 lb-ft. of torque. Pictured with Mopar's available Cross Ram Intake (P5007534) with Holley Carbs (P4452778 and P4452779) and Hemi Air Horns (P5007809).

<sup>1</sup> **P5155429** Crate Engine, 572 Hemi, Black, 650 Horsepower, 660 ft.-lbs Torque

<sup>1</sup> **P5155431** Crate Engine, 572 Hemi, Orange, 650 Horsepower, 660 ft.-lbs Torque

#### B. 528 Hemi Crate Engine- 640 Horsepower

Bigger is truly better in high-performance engines. Mopar has developed a huge 528 Hemi Crate Engine that cranks out a whopping 640 horsepower and 612 ft.-lbs. of torque! Mopar recommends that for maximum performance, an 850/900 cfm Holley carburetor and 2-1/4" exhaust headers be used (not available through Mopar). Shown with available Cross Ram Intake (P5007534), Holley Carburetors (P4452778 and P4452779), and Hemi Air Horns (P5007809). Refer to the Hemi and Fuel Systems sections of this catalog for details. Assembled by legendary Hemi engine builder Ray Barton for Mopar.

<sup>1</sup> **P5007630AE** Crate Engine, 528 Hemi, 640 Horsepower, 612 ft.-lbs. Torque

##### Specifications:

- Built with All-New Components
- Heavy-Duty, Siamese-Bore Cast Iron Block with Cross-Bolted Mains
- Aluminum Cylinder Heads
- Black Cast Aluminum Valve Covers
- Breathers
- Stainless Steel 2.25" Intake and 1.94" Exhaust Valves
- Heavy-Duty Single Valve Springs
- Premium Material Valve Stem Seals
- Camshaft grind selected by Ray Barton for Mopar's 528 Hemi
- Forged Pistons - 4.50" Bore, 10.0:1 C.R.
- Aluminum Single Plane Four-barrel Intake Manifold
- Forged Steel Crankshaft - 4.15" Stroke
- Precision Double Roller Timing Chain and Sprockets
- Chrome Front Cover
- Six-quart Center Sump Oil Pan (1970-71 B- and E-Body Style)
- Spark Plug Wires
- High-Performance Electronic Distributor
- Heavy-Duty Engine Stand and Shipping Crate

Note: 10.0:1 compression ratio with aluminum heads allows the use of current high-octane premium pump gasoline. Crate engines that change the emissions performance of the vehicle may not be legal for use on vehicles regulated for highway use in California and other states. Horsepower and torque ratings based on test engine. Ratings may vary on individual engines. Verify hood clearance for Intake Manifold.



A. P5155429



B.

## CRATE ENGINES

## A. 472 Hemi Crate Engine - 530 Horsepower

The 472 Hemi Crate Engine with increased displacement and power is an impressive step up from the familiar 426 Hemi. Mopar recommends the use of an 850 cfm vacuum secondary Holley carburetor and 2.00" exhaust headers (not available through Mopar).

<sup>1</sup> P5249666AE Crate Engine, 472 Hemi, 530 Horsepower, 530 ft.-lbs. Torque

## Specifications:

- Built with All-New Components
- Heavy-Duty Cast Iron Block with Cross-Bolted Mains
- Cast Iron Cylinder Heads
- Chrome Valve Covers
- Breathers
- Stainless Steel 2.25" Intake Valves and 1.94" Exhaust Valves
- Heavy-Duty Single Valve Springs with Dampers
- Premium Material Valve Stem Seals
- 301° Hydraulic Camshaft (248° duration @ .050") - 0.582"/0.563" Lift
- Forged Pistons - 4.250" Bore, 9.0:1 C.R.
- Aluminum Dual-Plane M1® Four-barrel Intake Manifold
- Forged Steel Crankshaft - 4.150" Stroke
- Premium Double Roller Timing Chain and Sprockets
- Front Timing Chain Cover
- Six-Quart Center Sump Oil Pan (1970-71 B- and E-Body Style)
- 7 mm Silicone Spark Plug Wires
- Spark Plugs
- High-Performance Electronic Distributor
- Heavy-Duty Engine Stand and Shipping Crate

Note: 9.0:1 compression ratio allows the use of current high-octane premium pump gasoline. Crate engines that change the emissions performance of the vehicle may not be legal for use on vehicles regulated for highway use in California and other states. Horsepower and torque ratings based on test engine. Ratings may vary on individual engines.



A.

---

## HEMI®, GEN II

### CRATE ENGINES

#### A. 426 Hemi Crate Engine - 465 horsepower

Remove and store your rare numbers-matching original Hemi and replace it with a Mopar 426 Hemi Crate Engine. Here's classic power to move you -- 465 horsepower and 465 ft.-lbs. of torque under your right foot. For maximum performance, Mopar recommends the use of a 750 cfm Holley carburetor (P4349228) and 2.00" exhaust headers (not available through Mopar).

<sup>1</sup> P5249667AE Crate Engine, 426 Hemi, 465 Horsepower, 465 ft.-lbs. Torque

##### Specifications:

- Built with All-New Components
- Heavy-Duty Cast Iron Block with Cross-Bolted Mains
- Cast Iron Cylinder Heads
- Chrome Valve Covers
- Breathers
- Stainless Steel 2.25" Intake Valves and 1.94" Exhaust Valves
- Heavy-Duty Single Valve Springs with Dampers
- Premium Material Umbrella-Type Valve Stem Seals
- 288° Hydraulic Camshaft (234° duration @ .050")- 0.499"/0.483" Lift
- Forged Pistons - 4.250" Bore, 8.7:1 C.R.
- Aluminum Dual-Plane Four-barrel Intake Manifold
- Forged Steel Crankshaft - 3.750" Stroke
- Premium Double Roller Timing Chain and Sprockets
- Front Timing Chain Cover
- Six-Quart Center Sump Oil Pan (1970-71 B- and E-Body Style)
- Spark Plug Wires
- High-Performance Electronic Distributor

Note: 8.7:1 compression ratio allows the use of current high-octane premium pump gasoline. Crate engines that change the emissions performance of the vehicle may not be legal for use on vehicles regulated for highway use in California and other states. Horsepower and torque ratings based on test engine. Ratings may vary on individual engines.

### BLOCKS

#### B. Blocks- Cast Iron, Siamese-Bore

Cast Iron Siamese-Bore 426 Hemi Blocks give engine builders the flexibility for a larger bore. Blocks can be bored to the stock size of 4.25", but are specifically designed to be bored larger. Mopar recommends that you sonic check each block if you plan to exceed as-shipped bore diameters.

<sup>1</sup> P5155072 Block, Cast Iron, 426 Hemi, Siamese-bore, Finished Bored at 4.25"

<sup>1</sup> P5153862 Block, Cast Iron, 426 Hemi, Siamese-bore, Finished Bored at 4.50"

<sup>1</sup> P5153942 Block, Cast Iron, 426 Hemi, Siamese-bore, Rough Bored at 4.24"

<sup>1</sup> P5153943 Block, Cast Iron, 426 Hemi, Siamese-bore, Rough Bored at 4.24", Tappet Machining Deleted

#### C. Blocks- Aluminum, Siamese-bore

Cast from 356 T-6 aluminum. Extra wall thickness in critical areas.

<sup>1</sup> P5153864 Block, Aluminum, 426 Hemi, Siamese-bore, Finished Bored at 4.50"



A.



B. P5153942



C. P5153864



## ENGINE INSTALLATION COMPONENTS

## A. Engine Installation Components

Mopar offers these much needed parts to make your 426 Hemi original production or crate engine installation easier. Each part sold individually, unless noted.

- P4510285 Bracket, Coil, 426 Hemi
- P4510287 Brackets, Engine Mounting, LH/RH, 426 Hemi Crate Engine, Engine Set
- P4510288 Insulator, Left Hand, 426 Hemi
- P4510289 Insulator, Right Hand, 426 Hemi
- P4510284 Oil Dipstick and Tube, 426 Hemi
- P4510283 Pulley, Crank Spacer, 3/16" Thick, 426 Hemi
- P4510281 Pulley, Crank, Belt Groove with Power Steering, 426 Hemi
- P4510286 Pulley, Crank, without Power Steering, 426 Hemi
- P4510282 Pulley, Water Pump, 426 Hemi



A.

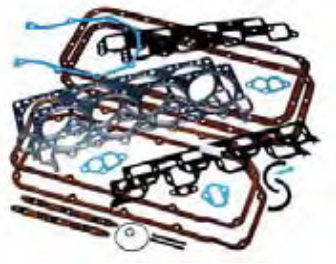

B.

## ENGINE BLOCK HARDWARE

## B. Engine Teardown Gasket Sets

All gaskets needed for complete Hemi engine teardown, including oil pan, cylinder head, valve cover, timing chain case cover, intake manifold and oil pump.

- P3412083 Gasket, Engine Teardown, 1966 and Newer 426 Hemi, Set

## C. Oil Seal Package

Includes crank seals and installation tool.

- P4271961 Oil Seal Package, 426 Hemi and Big Block



C.



D.

## D. Block Hardware Package

Includes all necessary dowels, plugs, bushings and keys, as well as core plugs, rear cam bearing plug, drive gear bushing and head dowels.

- P5155034 Hardware Package, Block, 426 Hemi/ Big Block, For Use With New B/RB Hemi and Wedge Engine Blocks
- P5249259AB Hardware Package, Block, 426 Hemi/ Big Block, For Use With Original Style Hemi Blocks

## E. Core Plugs

These round, press-in engine Core Plugs fit original style standard or Mopar race cast iron blocks.

- P5249708 Core Plugs, Brass, 426 Hemi and Big Block



D.



E.

Questions? Call the Mopar Direct Connection Techline at 1-888-528-HEMI (4364)

<sup>1</sup> Not legal on pollution-controlled vehicles or vehicles registered for highway use.

## HEMI®, GEN II

### CRANKSHAFTS AND HARDWARE

#### A. Forged Crankshafts - Machined

High-strength, high-quality Forged Crankshafts machined from 4340 steel. For high-performance race applications. Eight-bolt flange.

- <sup>1</sup> P5007251 Crankshaft, Forged, 3.75" Stroke, Full Radius, Eight-bolt, Balanced, 426 Hemi/ Wedge/ "RB" Engine, Race
- <sup>1</sup> P5007250 Crankshaft, Forged, 4.15" Stroke, Full Radius, Eight-bolt, Balanced, 426 Hemi/ Wedge/ "RB" Engine, Race

#### B. Crank Key Package

Locates crank sprocket on the nose of the crankshaft. Contains two keys.

- P5249822 Key Package, Crank, 426 Hemi/ Big Block/ Small Block/ Slant Six

#### C. Crank Bolt Set

Used to attach the vibration damper to the crankshaft.

- P5249562 Bolt Set, Crank, 1.25" Length, Thin Damper, 426 Hemi/ Big Block with O.E.M Dampers
- P5249557AB Bolt Set, Crank, 2.25" Length, 426 Hemi/ Big Block/ Small Block/ Aftermarket Dampers



A.

B.

### VIBRATION DAMPERS

#### D. Vibration Damper- Thin Crank

Designed for forged cranks and used primarily in Big Block and Hemi engines. It features 90° index markings and a symmetrical six-bolt pattern for pulley attachment. On pre-1972 engines with stock pulleys, minor modifications will be needed to attach bottom pulley. Not SFI approved. Must use 383/440 engine pulleys (not available through Mopar).

- <sup>1</sup> P3830183 Vibration Damper, Thin Crank, Hemi (crate engines) and Big Block without 400 Cast Crank or 440 with Six Pack Connecting Rods

#### E. Vibration Damper- SFI Approved

Features a steel ring and a universal six-bolt front pulley mount pattern.

- <sup>1</sup> P5249699 Vibration Damper, Steel, 1966-71 426 Hemi

#### F. Damper Degree Timing Tape

Improve timing accuracy with this Damper Degree Timing Tape. Marked in 90° increments. Self-adhesive strip adheres to the Crank Vibration Damper for clear identification of marks. Permits initial total spark advance up to 60° instead of only 10°-15° as on chain case timing tab.

- P4529070AB Damper Degree Timing Tape



C.

D.



E.

F. Damper Not Included



A.



B.



C.



D.



E.



F.



G.

## VIBRATION DAMPERS

### A. Oil Slinger

Protects front seal from excessive oil contact. Forces lubricant oil into chain.

**P5249636** Oil Slinger, 426 Hemi/ Big Block/ Small Block/ Slant Six/ 3.9L V6

## TIMING CHAIN AND SPROCKETS

### B. Double Roller Chain and Sprocket

Provide added durability and decreased rotational friction versus the production silent chains. Three machined keyways in crank sprocket to adjust cam timing. Kits include magnafluxed sprockets and roller timing chain.

<sup>1</sup> **P5249269** Chain and Sprockets, Roller, Double, 3-Bolt Mount, B/RB, Hemi

### C. Timing Chain Cover, Chrome

Includes cover, seal, and gasket.

**P4349816** Cover, Timing Chain, Chrome-Plated, Front

### D. Bolt Set, Timing Cover, Chrome

Engine chrome dress-up projects are incomplete without chrome bolts.

**P4452795** Bolt Set, Front Timing Cover, Chrome

### E. Front Cover Seal and Gasket

**P4876280** Seal, Front Cover, 426 Hemi/ Big Block/ Small Block

**P4876769** Gasket, Front Cover, Hemi/Big Block

## PISTONS AND CONNECTING RODS

### F. Forged Aluminum Piston

Features valve notches and floating pin. Top and second rings measure 1/16", while oil rings measure 3/16".

<sup>1</sup> **P4876026** Piston, Forged Aluminum, 4.500" Bore, 4.500" Stroke, 6.860" Rod, 12.5:1 C.R., 426 Hemi

### G. Forged Steel Connecting Rods

This durable connecting rod is forged from 4340 super high-strength steel. Includes high-strength bolts.

<sup>1</sup> **P5249898** Connecting Rod, Floating Pin, Forged Steel, 6.86" Center-to-Center, Hemi, Sold Individually

# HEMI®, GEN II

## CAMSHAFTS, LIFTERS, AND HARDWARE

### A. Camshafts, Purple Shaft

All Mopar Purple Shaft performance camshafts are designed, developed, dyno'd and track tested by engineers for increased power and rpm potential while maintaining reliability and the best possible low-speed characteristics, including torque and idle quality. Each package contains the camshaft, tappets, and instruction sheet. For 426-based Hemi engines.

- <sup>1</sup> P4529315 Camshaft, Hydraulic, Duration @ .050° 241° Intake / 241° Exhaust. Intake Centerline 106°. Lift .484" Intake / .475" Exhaust. Recommended springs P3690933, 1970-71 Street
- <sup>1</sup> P4529316AC Camshaft, Mechanical, Duration @ .050° 241° Intake/241° Exhaust. Intake Centerline 106°. Lift .484" Intake / .475" Exhaust. Recommended springs P3690933, 1966-69 Street

### B. Camshafts, High Performance, Hydraulic

- <sup>1</sup> P5155620 Camshaft, Hydraulic Roller, 0.566 / 0.544 Lift, 280 / 288 Adv. Duration
- <sup>1</sup> P5155621 Camshaft, Hydraulic Roller, 0.569 / 0.548 Lift, 286 / 294 Adv. Duration
- <sup>1</sup> P5155622 Camshaft, Hydraulic Roller, 0.574 / 0.551 Lift, 292 / 300 Adv. Duration
- <sup>1</sup> P5155618 Camshaft, Hydraulic, 0.502 / 0.486 Lift, 278 / 278 Adv. Duration
- <sup>1</sup> P5155619 Camshaft, Hydraulic, 0.534 / 0.517 Lift, 292 / 292 Adv. Duration

### C. Camshafts, High Performance, Mechanical

- <sup>1</sup> P5155626 Camshaft, Mechanical Roller, 0.811 / 0.793 Lift, 322 / 337 Adv. Duration
- <sup>1</sup> P5155625 Camshaft, Mechanical Roller, 0.822 / 0.793 Lift, 317 / 337 Adv. Duration
- <sup>1</sup> P5155623 Camshaft, Mechanical, 0.518 / 0.502 Lift, 270 / 270 Adv. Duration
- <sup>1</sup> P5155624 Camshaft, Mechanical, 0.557 / 0.54 Lift, 285 / 285 Adv. Duration

See chart for additional information.

### D. Mechanical Tappet

Sold individually.

- <sup>1</sup> P2843177 Tappet, Mechanical, 0.0005" Undersize

### E. Roller Tappet Set

Includes matched pair of roller tappets with guide bar.

- <sup>1</sup> P4452920 Tappet, Roller, for Bushed Lifter Bores, Hemi/Big Block, Set

### F. Hydraulic Tappet

Sold individually.

- <sup>1</sup> P4006767 Tappet, Hydraulic, Hemi/ Big Block



A.

B.



C.

D.



E.

F.

## CAMSHAFTS, LIFTERS, AND HARDWARE

## A. Pushrods

Engineered to be installed in your Hemi® engine rebuilding project. Pushrods are 3/8" diameter and sold as complete engine sets or individually for service (426 Hemi).

- <sup>1</sup> P4529561 Pushrod, Hydraulic, Overall Length 10.64" Intake, 11.62" Exhaust, Set of 16
- <sup>1</sup> P4529547 Pushrod, Hydraulic, Overall Length 10.64" Intake, Sold Individually
- <sup>1</sup> P4529548 Pushrod, Hydraulic, Overall Length 11.62" Exhaust, Sold Individually
- <sup>1</sup> P4529549 Pushrod, Mechanical, Overall Length 10.81" Intake, Sold Individually

Note: Hydraulic pushrods are made to 1970-71 OEM lengths for use with OEM height lifters. Check overall lengths for your application before purchase.

## B. Camshaft Bearings

Complete engine set.

- P5249711 Bearings, Camshaft, Babbitt Applications, 426 Hemi/ Big Block

## C. Offset Camshaft Bushing Set

Includes five bushings: 2°, 4°, 6°, 8° offset, and one on-center bushing. Color guide only - check installations with dial indicator. Gold = 2°, Copper = 4°, Silver = 6°, Black = 8°

- P3690936 Bushing Set, Camshaft, Offset, 426 Hemi/ Big Block/ Slant Six

## D. Camshaft Sprocket Attaching Hardware

- P6030269 Bolt, Camshaft Sprocket, For One-Bolt Mounting, 426 Hemi/ Big Block, Sold Individually
- P5007801 Bolt, Camshaft Sprocket, For Three-bolt Mounting, 426 Hemi/ Big Block, Set of three
- P2120930 Bolt, Camshaft, Sprocket, For Three-Bolt Mounting, 383/440/426, Sold Individually

## CYLINDER HEADS, GASKETS, AND HARDWARE

## E. Cylinder Heads, Aluminum

Interchangeable with production cast iron heads and offers a weight reduction of 50 lbs. per engine set. Features include single plug per cylinder (capability for dual), common 2.25" intake and 1.94" exhaust valve machining, 170 cc combustion chamber, valve seats and guide inserts. Includes valves, springs, retainers and keepers.

- <sup>1</sup> P5153875 Cylinder Head, Aluminum, Assembly, as used on 528 Hemi Crate Engine
- <sup>1</sup> P5153779 Cylinder Head, Aluminum, Bare, 426 Hemi



A.



B.



C.



D.



E.

Questions? Call the Mopar Direct Connection Techline at 1-888-528-HEMI (4364)

<sup>1</sup> Not legal on pollution-controlled vehicles or vehicles registered for highway use.

## HEMI®, GEN II

### CYLINDER HEADS, GASKETS, AND HARDWARE

#### A. Cylinder Heads, Cast Iron

Designed for more power. Stiffer and stronger than original, increased material permits porting for improved airflow. Features the same outward appearance as the original 1966-1971 heads, except for shape of alternator boss. All components attach the same as original (intake and exhaust valves, valve guides, seats, rocker gear, etc.). Features 170 cc combustion chamber and 2.25" intake and 1.94" exhaust valve machining.

<sup>1</sup> P4876855 Cylinder Head, Cast Iron, Assembly, as used on 426 Hemi Crate Engine

<sup>1</sup> P4529898 Cylinder Head, Cast Iron, Bare, 426 Hemi

#### B. Cylinder Head Gasket, Composite Material

Can be used for standard and high-compression (up to 12.5:1) 426-based Hemi engines. These premium high-quality head gaskets offer maximum sealing and have a thickness of 0.040" to 0.042". Sold in pairs.

P4529456 Gasket, Cylinder Head, Composite Material, 4.250" - 4.310" Bore Range

P4876071 Gasket, Cylinder Head, Composite Material, 4.380" - 4.500" Bore Range

#### C. Cylinder Head Gasket, Multi-Layer Steel

Hemi multi-layer steel gaskets. Sold in pairs.

P5155234 Gasket, Multi-layer Steel, 0.025" Compressed Thickness, for 4.250" Bore Diameter. Especially recommended for use with aluminum heads.

#### D. Cylinder Head Hardware

P5155279 Bolt Set, Cylinder Head, For Current Replacement Blocks, Includes Head Bolts, Washers, Nuts, and Studs (4.50" Long) for One Cylinder Head, 426 Hemi,

P4529978 Bolt Set, Cylinder Head, For Original and Restoration Blocks. Includes Head Bolts, Washers, Nuts, and Studs (3.86" Long) for One Cylinder Head. Requires Additional 4 1/2" Inboard Stud for Use With Current Replacement Blocks, 426 Hemi

P5249570 Hardware Kit, Cylinder Head, Includes Dowels (10) and Freeze Plugs (4), 426 Hemi

### VALVE COVERS AND HARDWARE

#### E. Valve Covers, Cast Aluminum, Black Wrinkle

Painted black wrinkle and finned with Hemi logo cast in. For single-plug cylinder head applications. Uses Street Hemi valve cover rail. Gaskets included. Takes P5249949 oil cap.

P5007796 Valve Cover, Cast Aluminum, Black Wrinkle, 1966 and Later Street Hemi, Set



A. P4529898

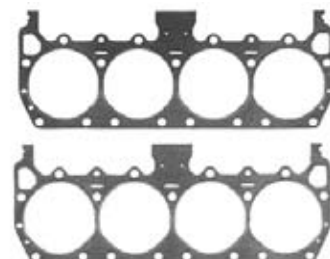

B.



C.



D.



E.

## VALVE COVERS AND HARDWARE

## A. Valve Covers, O.E. Stamped Steel, Black Wrinkle

Mopar takes another giant step to help the restoration crowd with these O.E. Black Wrinkle 426 Hemi® Valve Cover Sets. Original equipment for all 1966-1971 426 Hemi engines, these stamped steel black wrinkle covers have the spark plug wire brackets and rubber coated alternator wiring looms. Sets include left and right valve covers, hold-down studs and nuts. P4529399 also includes chrome breather cap, metal PCV valve and chrome PCV cap. Set P4510577 includes chrome oil fill cap and grommets for PCV and breather.

**P4529339** Valve Cover, Black Wrinkle, Original Equipment, 1966-69 426 Hemi, Set

**P4510577** Valve Cover, Black Wrinkle, Original Equipment, 1970-71 426 Hemi, Set

## Valve Covers, Cast Aluminum, Painted (Not Shown)

**P5155433** Valve Cover, Cast Aluminum, Black, 572 Hemi, Set

**P5155432** Valve Cover, Cast Aluminum, Orange, 572 Hemi, Set

## B. Valve Covers, Chrome

Features quality chrome plating. Includes two valve covers and gaskets.

**P4529338** Valve Cover, Chrome, 426 Hemi, Set

**P4120353** Gasket, Valve Cover, Rubber Reinforced Cork, Replacement, Two Per Set, 1966 and Newer Street Hemi

## C. Valve Cover Service Parts, Cast Aluminum Covers

These parts will come in handy when servicing Mopar cast aluminum valve covers (P5007796).

**P5007499** Cap, Breather, Bolt-On

**P5249949** Cap, Oil Fill, Screw-In

**P5249947** Stud and Nut Set, 20 Pieces Each

## D. Valve Cover Service Parts, Stamped Steel Covers

Contains 20 studs and 20 nuts, and allows you to retain factory valve covers. For use with all stamped (sheet metal) covers.

**P4529897** Stud and Nut Set, 20 Pieces Each, 1966-71 426 Hemi

## E. PCV Package

Use this original equipment 426 Hemi® PCV Package for restoration or repair of Hemi valve covers. This factory reissue kit contains one PCV valve cap, a PCV valve and nut, and one PCV valve retaining spring. Push-on-style PCV valve cap is chrome and fits 1964-69 Hemi valve covers, including Mopar Chrome or Black Wrinkle valve cover kits. Can be used to service non-Hemi, 1960s-era push-on-style PCV valves.

**P4529895** PCV Package, 1964-69 426 Hemi



A.



B.



C.



D.



E.

## HEMI®, GEN II

### VALVE COVERS AND HARDWARE

#### A. Breather Cap, Chrome

For use with stamped steel Hemi valve covers, both black wrinkle and chrome  
**P4529896** Breather Cap, Chrome, Push-In, 1964-69 426 Hemi

### VALVES AND VALVE TRAIN HARDWARE

#### B. Valves

These stainless steel 426 Hemi Valves have swirl-polished underheads with no flat or ski jump areas. Feature a 5/16" stem diameter and one square groove. For use with cast iron and aluminum cylinder heads.

**P5249204** Valve, Exhaust, 1.94" Diameter, 4.86" Stem Length, 426 Hemi

**P5249203** Valve, Intake, 2.25" Diameter, 5.40" Stem Length, 426 Hemi

#### C. Valve Seals

Made of high-temp Viton® material, these Valve Seals feature a full or semi-umbrella shape for best dual-purpose use. Helps prevent oil seepage down valve guides. Not recommended for use with dual valve springs. Sold in sets of 16.

<sup>1</sup> **P5249661** Valve Seals, 5/16" Stem, 0.530" Guide, 426 Hemi and 5.2L/5.9L Magnum/Jeep Engines

#### D. Valve Stem Lash Caps

These lash caps are 0.080" thick and fit between the end of the valve and the rocker arm tip. They are made of hardened steel for improved rocker tip durability. Larger area than stock valve tip to help spread the rocker loads. Sold in sets of 16.

**P4120635** Lash Caps, Valve Stem, 5/16" Stem, 426 Hemi/ Big Block/ Small Block/ Truck Magnum/Jeep Engines

#### E. Valve Guides

These silicon-bronze alloy Valve Guides are designed for aluminum heads. They must be pressed into the head once it is prepped. Guide replacement in aluminum heads requires removal of the old guide and some prep to resize the guide holes. Guide inside diameter must be sized for the valve stem once pressed into the head. Can be used to modify, rebuild or repair aluminum heads. Sold individually. For 426-based Hemi.

**P4876710** Valve Guide, 5/16" Valve Stem, Exhaust

**P4876709** Valve Guide, 5/16" Valve Stem, Intake

#### F. Valve Keepers (Split Locks)

These single-groove-style Hemi® Split Locks are made from hardened material. They feature a 5/16" stem diameter and can be used for restoration or performance applications. Sold as cylinder head sets of 16 pieces. Note that two sets are required for all V8 engines. For 426-based Hemi.

**P4529038** Valve Keepers, 10°, Use with Retainers P4120785 and P4286775

**P4120634** Valve Keepers, 7°, Use with Retainers P4452769 and P4529288



A.

B.



C.

D.



E.

F.



## VALVES AND VALVE TRAIN HARDWARE

## A. Valve Springs

High-pressure Valve Springs can be used on exhaust and intake valves for all high-performance applications. They feature a shorter fully-compressed height and allow for increased valve lift. Springs maintain spring load at higher rpms...a must for high-performance cams. Sold individually. With a single spring, the damper is installed inside the main spring; with a dual spring, the damper is installed between the inner and outer springs. There are no dampers in the triple springs. The retainers listed are the basic recommendation. Check the actual retainer listing for other options: added installed height, materials and lock size. For 426-based Hemi.

<sup>1</sup> P4286812	Valve Spring, Single, 0.430"/0.460" Lift
<sup>1</sup> P3690933	Valve Spring, Single, 0.440"/0.500" Lift
<sup>1</sup> P5249848	Valve Spring, Single, 0.480"/0.540" Lift
<sup>1</sup> P2806077	Valve Spring, Double, 0.500"/0.610" Lift
<sup>1</sup> P2946353	Valve Spring, Double, 0.520"/0.700" Lift
<sup>1</sup> P4876064	Valve Spring, Double, 0.590"/0.640" Lift

See chart for additional information.

## B. Valve Spring Retainers

Available in three levels of performance: steel for restoration, chrome moly for heavy-duty applications, and titanium for top-level race performance. Sold individually.

P4529288	Retainer, Chrome Moly, 5/16", Single/Dual, Std Height, 7°
P4452769	Retainer, Steel, 5/16", Single, Std Height, 7°
P4120785	Retainer, Titanium, 3/8", Dual, Std Height, 10°
P4286775	Retainer, Titanium, 3/8", Triple, .060" Increase, 10°



A.



A.



B.



B.

## HEMI (GEN II) VALVE SPRINGS

Part Number	Installed Ht.	Description	OD	Wire Diameter	Lift Range	Material	Retainers
P4286812	1.83"/1.86"	Single/damper	1.49"	0.208"	0.430"/0.460"	Chrome vanadium	P4452033
P3690933	1.83"/1.86"	Single/damper	1.53"	0.224"	0.440"/0.500"	Chrome vanadium	P4452769, P4529288, P5007858
P5249848	1.86"/1.87"	Single/damper	1.55"	0.216"	0.480"/0.540"	Chrome silicon	P4452769, P4289288
P2806077	1.83"/1.86"	Dual/damper	1.52"	0.215"	0.500"/0.610"	Chrome vanadium	P4529288, P4120785
P4876064	1.86"/1.88"	Dual/damper	1.60"	0.216"	0.590"/0.640"	Chrome silicon	P4529288, P4120785
P4007536	2.00"/2.02"	Triple	1.62"	0.225"	0.640"/0.745"	Chrome silicon	P4286775
P5249849	2.00"/2.02"	Dual/damper	1.55"	0.216"	0.650"/0.750"	Chrome silicon	P4120785

1. All valve springs are sold individually.

2. With a single spring, the damper is installed inside the main spring; with a dual spring, the damper is installed between the inner and outer springs. There is no damper in the triple springs.

3. Retainers listed are the basic recommendation. Check the actual retainer listing for other options-added installed height, materials, lock size.

Questions? Call the Mopar Direct Connection Techline at 1-888-528-HEMI (4364)

<sup>1</sup> Not legal on pollution-controlled vehicles or vehicles registered for highway use.

## HEMI®, GEN II

### ROCKER ARMS, SHAFTS, SUPPORTS, AND HARDWARE

#### A. Rocker Arms, Mechanical

Made of SAE 1041 forged steel, featuring hardened valve tip pads (to help prevent scuffing) and internal bushings. Can serve as a replacement for original production rockers. Fits both cast iron and aluminum 426 Hemi heads. Sold individually. High-ratio rockers may require grinding on block and head for push rod clearance.

<sup>1</sup> P4529708AC Rocker Arm, Mechanical, 1.65 Ratio, Exhaust

<sup>1</sup> P4529707AC Rocker Arm, Mechanical, 1.70 Ratio, Intake

#### B. Rocker Arm Set

Independent shaft Rocker Arm Set designed and patented by Hemi legend Ray Barton. If your Hemi is running all-out, you know the need for a full-roller rocker system that maintains valve train geometry throughout the RPM range and the entire range of rocker arm travel. Reduces friction and valve train weight. Provides easy access to valve springs on race day so you can make critical adjustments and changes quickly. Case hardened and tempered shafts, 7/16" diameter adjusters and jam nuts.

<sup>1</sup> P5153782 Rocker, Roller, Aluminum, Race, 426 Hemi, Set

#### C. Rocker Arms, Roller Tip, Stainless

Made from high-strength, investment grade cast stainless steel. Each features a roller tip to reduce friction and improve geometry. Designed for drag racing and high strength, they use standard Hemi rocker ratios. Sold individually. For 426 Hemi.

<sup>1</sup> P5249603AB Rocker, Stainless Steel, Roller Tip, 1.50 Ratio, Intake

<sup>1</sup> P5249604AB Rocker, Stainless Steel, Roller Tip, 1.55 Ratio, Exhaust

#### D. Rocker Shafts

Chrome Rocker Shafts for use with mechanical valve gear. Sold individually.

P5249632 Rocker Shaft, Exhaust, On-Center, 426 Hemi

P5249631 Rocker Shaft, Intake, On-Center, 426 Hemi

#### E. Rocker Shaft Springs

For use on all production-based Hemi® valve gear. Used to locate rockers on the shaft. Includes 14 long springs and two short springs. Package contains one engine set.

P4452827 Rocker Shaft Springs, 426 Hemi

#### F. Rocker Shaft Stand

Blue anodized, extruded aluminum Rocker Shaft Supports for 426 Hemi®. Complete engine set includes ten pieces plus hardware.

P5249505 Rocker Shaft Stand, 426 Hemi

#### G. Rocker Shaft End Plugs

Sold as a set of four. They do not fit aftermarket rocker shafts.

P5249633 Rocker Shaft End Plugs, 426 Hemi/Big Block



A.



B.



C.



D.



E.



F.



G.

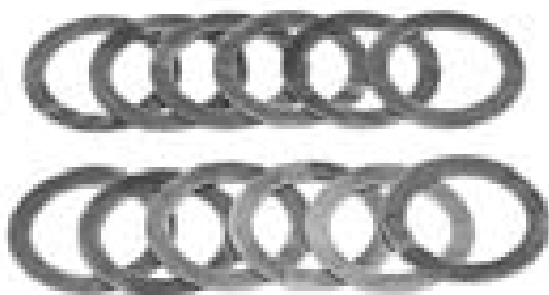

A.



B.



C.



D.

## ROCKER ARMS, SHAFTS, SUPPORTS, AND HARDWARE

### A. Rocker Shim Package

Use to improve adjustable rocker arm-to-valve tip alignment, 0.015" thick. Twelve per set, for 426 Hemi.

**P3690896** Rocker Arm Spacer Set, 0.015" Thick, .878" I.D., 1.246" O.D., Set of 12

## INTAKE MANIFOLDS, HARDWARE, AND GASKETS

### B. Single Plane Intake Manifold

For Hemi engines with serious airflow requirements. This intake was designed by Ray Barton for 500+ inch Hemi engines or for applications intending to make over 600 HP. The intake manifold can be the limiting factor in a heavy-breathing engine like Mopar's Hemis. Don't let your top end get all bottled up. Increased plenum volume over most Dual Plane manifolds. Smooth transition to intake runners from plenum which increases air flow velocity -- that's what your high-HP Hemi needs. Integral valley cover pan cleans things up nicely. Carburetor flange machined for 4150-series Holley.

<sup>1</sup> **P5153781** Intake Manifold, Aluminum, Single Plane, Holly 4150 Series, 426 Hemi

### C. Dual Plane Intake Manifold

This revised four-barrel aluminum Dual Plane Intake Manifold features a rectangle port and fits all Hemi 426/472/528 engines. Stock exhaust heat is now located on the rear of the manifold, just like the original dual four-barrel production in-line manifold.

<sup>1</sup> **P4876188** Intake Manifold, Aluminum, Dual Plane, Four-barrel Carburetor, 426, 472, 528 Hemi

### D. Dual Quad Intake Manifold- Holley Carb

This new aluminum in-line Dual Quad Hemi Intake Manifold is based on the Marine version and is built from the original tooling. Machined to accept aftermarket AFB or Holley carburetors (P4452778 rear, P4452779 front - see Fuel Systems section of this catalog). Will fit production 426 Hemi heads and has provisions for manifold heat and power brakes. It retains the stock height of the production 1966-71 Street Hemi AFB intake manifold. Production AFB air cleaner baseplate/lid will need to be changed or modified. Some O.E. and aftermarket linkage components and fuel lines are needed to complete the installation.

<sup>1</sup> **P4510633** Intake Manifold, Aluminum, Dual Quad, Holley Carb Set Up, 426 Hemi

## HEMI®, GEN II

### INTAKE MANIFOLDS, HARDWARE, AND GASKETS

#### A. Dual Quad Intake Manifold- AFB Carb

Back by popular demand - the original 1966-71 Street In-line, Dual Quad Intake Manifold. Uses original Carter AFB carburetors and maintains mounting bosses for throttle return brackets. Features factory casting numbers along with the Chrysler Pentastar logo. Designed specifically for the 426 Street Hemi.

<sup>1</sup> P5153737 Intake Manifold, Aluminum, Dual Quad, AFB Carb Set Up, 426 Street Hemi

#### B. Cross Ram Intake Manifold

This aluminum Cross Ram Intake Manifold features rectangle ports and is designed for two four-barrel carburetors. May require hood modifications on some vehicles due to increased height of manifold.

<sup>1</sup> P5007534 Intake Manifold, Aluminum, Cross Ram, Dual Four-barrel Carburetors, 426/472/528 Hemi

P5007334 Gasket, Cross Ram, For Removable Top

#### C. Dual Plane Intake Manifold - Six Pack

This intake manifold is designed to allow the use of (3) 2-barrel Six Pack carburetors on a 426 C.I.D. Chrysler Hemi engines. This intake manifold has mounting bosses on the drivers side that are the same as the stock style dual 4 barrel Hemi intake. The carburetor pads have the same dimensions and position as a 1969-1971 440 C.I.D. Chrysler Six Pack. This intake manifold can be used with the 440 carburetors, fuel line kit, linkage kit, and air cleaner. be sure to check for hood clearance with the air cleaner.

<sup>1</sup> P5153738 Intake Manifold, Dual Plane, Six Pack, 426 Hemi

#### D. Intake Manifold Gasket Sets

Custom-fit set comes complete to service one engine. Includes gaskets and end seals.

P4120086 Gasket, Intake Manifold, 0.060" Thick, 426 Hemi Except D4D6, Set

P4529534 Gasket, Intake Manifold, 0.090" Thick, 426 Hemi Except D4D6, Set

P5155316 Gasket, Intake Manifold, 0.103" Thick, 426 Hemi, Except D4D6, Set

P4532199 Gasket, Intake Manifold, 0.120" Thick with .005" Tolerance, 426 Hemi

#### E. Intake Manifold Screw Set

Set of 16 Allen screws and washers to attach the Race Hemi Cross Ram Intake Manifold.

P4529330 Screw, Intake Manifold, A-990 Cross Ram, Hemi, Set



A.



B.



C.



D.



E.

## INTAKE MANIFOLDS, HARDWARE, AND GASKETS

### A. Intake Manifold Heat Shield

Original equipment for all 426 Street Hemi intake manifolds. Bolts to the bottom of the intake manifold to prevent hot engine oil from heating the manifold and robbing horsepower. Also fits Aluminum Dual Plane Intake Manifold P4876188 and Aluminum Dual Quad Intake Manifold P5153737.

**P4529431** Heat Shield, Intake Manifold, 426 Hemi

### B. Intake Manifold Plug Package

Includes eight intake manifold plugs. Used in 426 and Hemi® Cross Ram Intake Manifolds.

**P5249926** Plug Package, Intake Manifold, Cross Ram, Hemi and Max Wedge. Includes eight intake manifold plugs.



A.

B.

## OILING COMPONENTS

### C. Oil Pans

Includes factory engineered and approved oil pan, drain plug and washer. Center sump style is used on passenger car applications, while the rear sump style is used for pickups. Windage Trays may be used if desired.

**P4529884** Oil Pan, Six-Quart, Center Sump, 1970-71 426 Hemi E-Body

**P5007816** Oil Pan, Eight-Quart, Center Sump, Hemi/Big Block



C.

D.

### D. Windage Trays

Designed to provide improved engine lubrication by reducing interior windage at higher engine speed. Packages include tray and two pan gaskets.

**P4120998** Windage Tray, 3.75" Stroke

**P5007345** Windage Tray, 4.15" Stroke

### E. Oil Pan Gaskets

For Big Block and Hemi applications. Note that two are required for Windage Tray applications.

**P4452099** Gasket, Oil Pan, Race, Set of Two

**P3412049** Gasket, Oil Pan, Sold Individually

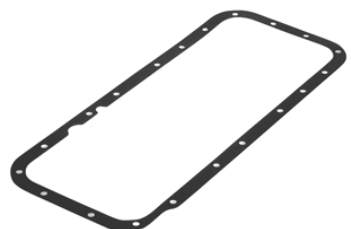

E.

F.

### F. Oil Pan Bolt Set

**P4120613** Bolt Set, Oil Pan, 426 Hemi, Big Block/ Small Block, Set of 20 Bolts

## HEMI®, GEN II

### OILING COMPONENTS

#### A. Oil Pickup and Screen Assemblies

Factory original reissue.

- P5007818** Oil Pickup and Screen Assembly, Eight-Quart, 1/2" Pipe, Use with Oil Pan P5007816
- P4529566** Oil Pickup and Screen Assembly, Five-Quart, 1/2" Pipe, 1966-69 426 Hemi
- P4529567** Oil Pickup and Screen Assembly, Six-Quart, 1/2" Pipe, 1970-71 426 Hemi, Use with Oil Pan P4529884
- P5249818** Oil Pickup and Screen Assembly, Six-Quart, 1/2" Pipe, Siamese Bore, Not Raised Cam, 426 Hemi and Big Block

#### B. Oil Pressure Relief Spring

Increases engine oil pressure over stock spring for high-performance applications. Delivers up to 70 lbs. of oil pressure. Includes a cap and instructions.

- P4286571** Spring, Oil Pressure Relief, B/RB/Hemi

#### C. Oil Pump Assembly

This high-output assembly provides a 25% increase in oil volume. Ideal replacement for stock pump in high-performance applications.

- P4286590** Oil Pump Assembly, Use With 02084355 Service Gasket

#### D. Oil Pump Priming Shaft

Special hardened steel priming shaft fits on any 3/8" or larger drill. Insert shaft into hole where distributor fits. Pressurizes oil galleries to ensure against dry starts and engine damage.

- P4286800** Shaft, Oil Pump Priming

#### E. Distributor Drive Gear Assemblies

Features a hardened tip shaft with full radius blend from hex to round and pinned gears.

- P3571071** Distributor Drive Gear, Flat Tappet Cams
- P3412064** Distributor Drive Gear, Flat Tappet Cams, Milodon Oil System
- P3690875** Distributor Drive Gear, Roller Tappet, Aluminum-Bronze Gear
- P3690876** Distributor Drive Gear, Roller Tappet, Aluminum-Bronze Gear, Milodon Oil System

#### F. Oil Filter- Performance

Engineered to meet the demands of heavy-duty and high-performance applications. Filter is black with Mopar Performance Pentastar logo.

- P4452890** Oil Filter, High-Performance, Black Finish, 6/8 Cylinder Engines



A.



B.



C.



D.



E.



F.



A.



B. P4529805



C.



D.



E.



F.



G.

## OILING COMPONENTS

### A. Oil Filter - Race

High-performance, heavy-duty oil filter has a thicker canister with high burst strength. Filter is black with Mopar Performance Pentastar logo.

**P4529190** Oil Filter, Race, Black Finish, 426 Hemi, Big Block, Small Block

### B. Oil Filter- Restoration

Mopar has reissued these service replacement oil filters, used in the 1960s and 1970s. The white filter was used from the 1960s throughout the 70s. The high-performance white filter (P4529805) was recommended for use in competition from 1965 to 1974. The black filter was used from the late 1950s through the early 60s. These filters may not fit some V8 applications (those after 1972 requiring short filters).

**P4529806** Oil Filter, Restoration, Black with Yellow Mopar logo, 1962-66 V8

**P4529805** Oil Filter, Restoration, High-Performance, White with Red Stripe

## COOLING SYSTEMS

### C. Lightweight Aluminum Water Pump

Fully assembled and ready to install. Features an eight-blade impeller. Dimensions are same as stock cast iron version.

**P5007643AB** Water Pump, Aluminum, B/RB/ Hemi

### D. Water Pump Housing

Lightweight aluminum water pump housing. More than eight pounds lighter than typical production cast iron housing. Has dual alternator bracket mounting bosses, so it fits all "B" and "RB" engines, 1958-74.

**P4286900** Water Pump Housing, Aluminum, B/RB/ Hemi

Note: Radiator hose inlet is on the driver's side, so it cannot be used on 1973-up vehicles that have the hose on the passenger side.

### E. Water Pump Installation Kit

Includes water pump gasket, pump housing gasket, plugs, water pump screws, and long and short housing screws.

**P5007449** Water Pump Installation Kit

### F. Bolt Set, Water Pump Housing, Chrome

Engine chrome dress-up projects are incomplete without chrome bolts.

**P5007621** Bolts, Water Pump, Chrome

### G. 90 Degree Water Neck Outlet

Cast aluminum 90° Water Neck Outlet provides greater flexibility in routing cooling system hoses and improves the appearance of the engine compartment. Features three-direction capability, ideal for compact engine compartments.

**P5249191** Thermostat Housing, 90 Degrees

## HEMI®, GEN II

### COOLING SYSTEMS

#### A. Thermostat Housing, Chrome

This high-quality Chrome Thermostat Housing is made of heavy-duty material. Includes gasket and two chrome bolts.

**P4286759** Water Neck, Chrome, Up To 1978, V8

#### B. Viscous Fan Package

Most late 1960s and early 1970s factory-built muscle cars were equipped with viscous fans for cooling purposes. This package provides thermostatically controlled cooling, and includes a lightweight balanced fan. Offers up to 15 horsepower gain on typical high-performance V8s.

**P4120758** Viscous Fan Package, 18" fan. 3.25 Pitch

#### C. Thermostat

This heavy-duty thermostat can handle increased heat management duties in high-performance engines. Comes with replacement gasket.

**P4876307** Thermostat, 180 Degree, 426 Hemi/Big Block/Small Block/Slant Six Engines, Up to 1978



A.



B.



C.



440 SIX BARREL



27-11-1996 18:25

## BIG BLOCK

### BLOCKS

#### A. Blocks- Cast Iron, Siamese-Bore

Mopar Siamese-bore Big Blocks are specifically designed to be bored larger. Mopar still recommends that you sonic check each block if you exceed as-shipped bore diameters.

- <sup>1</sup> P5153860 Block, Cast Iron, 440 Wedge, Siamese-Bore, Finished Bored at 4.50"
- <sup>1</sup> P5153944 Block, Cast Iron, 440 Wedge, Siamese-Bore, Rough Bored at 4.31"

### ENGINE BLOCK HARDWARE

#### B. Oil Seal Package

Includes crank seals and installation tool.

- P4271961 Oil Seal Package, 426 Hemi and Big Block

#### C. Core Plugs

Round, press-in engine block Core Plugs fit original style or Mopar Race Cast Iron Blocks.

- P5249708 Core Plugs, Brass, 426 Hemi and Big Block

#### D. Block Hardware Package

- P5155034 Hardware Package, Block, 426 Hemi/ Big Block, For Use With New B/RB Hemi and Wedge Engine Blocks
- P5249259AB Hardware Package, Block, 426 Hemi/ Big Block, For Use With Original Style Hemi Blocks

### CRANKSHAFTS AND HARDWARE

#### E. Forged Race Crankshafts

High-strength, high-quality Forged Steel Cranks machined from 4340 steel. For high-performance race applications. Eight-bolt flange "RB" main journal size.

- <sup>1</sup> P5007251 Crankshaft, Forged, 3.75" Stroke, Full Radius, Eight-bolt, Balanced, 426 Hemi/ Wedge/ "RB" Engine, Race
- <sup>1</sup> P5007250 Crankshaft, Forged, 4.15" Stroke, Full Radius, Eight-bolt, Balanced, 426 Hemi/ Wedge/ "RB" Engine, Race

#### F. Crank Key Package

Used to locate the crank sprocket on the nose of the crankshaft. Contains two keys.

- P5249822 Key Package, Crank, 426 Hemi/ Big Block/ Small Block/ Slant Six



A. P5153944



B.



C.



D.



D.



E.

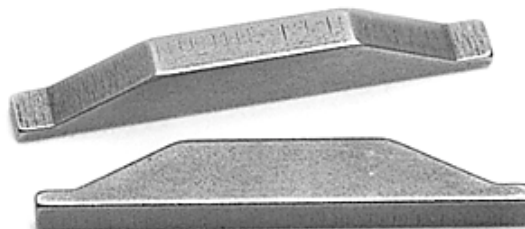

F.

## CRANKSHAFTS AND HARDWARE

## A. Crank Bolt Set

Used to attach the vibration damper to the crankshaft.

- P5249562** Bolt Set, Crank, 1.25" Length, Thin Damper, 426 Hemi/ Big Block with O.E.M Dampers
- P5249557AB** Bolt Set, Crank, 2.25" Length, 426 Hemi/ Big Block/ Small Block/ Aftermarket Dampers



A.



B.

## VIBRATION DAMPERS

## B. Vibration Damper- SFI Approved

Features a steel ring and a universal, symmetrical six-bolt front pulley mount pattern.

- <sup>1</sup> **P5249694** Vibration Damper, Steel, 440 Forged Crank, 1962-70 361/383 "B" Forged Crank, 413/426 Wedge

## C. Vibration Damper- Thin Crank

Designed for forged cranks. Features 90° index markings and a symmetrical six-bolt pattern for pulley attachment. On pre-1972 engines with stock pulleys, minor modifications will be needed to attach bottom pulley. Not SFI-approved. Must use 383/440 engine pulleys (not available through Mopar).

- <sup>1</sup> **P3830183** Vibration Damper, Thin Crank, Hemi (crate engines) and Big Block without 400 Cast Crank or 440 with Six Pack Connecting Rods



C.



D. Damper Not Included

## D. Damper Degree Timing Tape

Improve timing accuracy with this Damper Degree Timing Tape. Marked in 90° increments. Self-adhesive strip adheres to the crank vibration damper for clear identification of marks. Permits reading spark advance up to 60° instead of only 10°-15° as on chain case timing tab.

- P4529070AB** Damper Degree Timing Tape

## E. Oil Slinger

Protects the front seal from excessive oil contact. Forces lubricant oil into chain.

- P5249636** Oil Slinger, 426 Hemi/ Big Block/ Small Block/ Slant Six/ 3.9L V6

## TIMING CHAIN AND SPROCKETS

## F. Double Roller Chain and Sprocket

High-strength Double Roller Chain provides added durability and decreased rotational friction versus the production silent chain. Has three matched keyways on crank sprocket to adjust cam timing. Kit includes magna-fluxed sprockets and roller timing chains.

- <sup>1</sup> **P5249268** Chain and Sprockets, Roller, Double, 1-Bolt Mount, B/BB, Hemi
- <sup>1</sup> **P5249269** Chain and Sprockets, Roller, Double, 3-Bolt Mount, B/BB, Hemi



E.



F.

Questions? Call the Mopar Direct Connection Techline at 1-888-528-HEMI (4364)

<sup>1</sup> Not legal on pollution-controlled vehicles or vehicles registered for highway use.

## BIG BLOCK

### TIMING CHAIN AND SPROCKETS

#### A. Timing Chain Cover, Chrome

Package includes cover, seal, and gasket.

**P4349816** Cover, Timing Chain, Chrome-Plated, Front

#### B. Bolt Set, Timing Chain Cover, Chrome

Engine chrome dress-up projects are incomplete without chrome bolts.

**P4452795** Bolt Set, Front Timing Cover, Chrome

#### C. Front Cover Seal and Gasket

**P4876280** Seal, Front Cover, 426 Hemi/ Big Block/ Small Block

**P4876769** Gasket, Front Cover, Hemi/Big Block



A.

### CAMSHAFTS, LIFTERS, AND HARDWARE

#### D. Camshafts, High Performance, Hydraulic

<sup>1</sup> **P5155597** Camshaft, Hydraulic Roller, 0.538 / 0.534 Lift, 274 / 282 Adv. Duration

<sup>1</sup> **P5155598** Camshaft, Hydraulic Roller, 0.541 / 0.537 Lift, 280 / 288 Adv. Duration

<sup>1</sup> **P5155599** Camshaft, Hydraulic Roller, 0.544 / 0.541 Lift, 286 / 294 Adv. Duration

<sup>1</sup> **P5155600** Camshaft, Hydraulic Roller, 0.549 / 0.544 Lift, 292 / 300 Adv. Duration

<sup>1</sup> **P5155589** Camshaft, Hydraulic, 0.432 / 0.444 Lift, 250 / 260 Adv. Duration

<sup>1</sup> **P5155590** Camshaft, Hydraulic, 0.447 / 0.455 Lift, 256 / 268 Adv. Duration

<sup>1</sup> **P5155591** Camshaft, Hydraulic, 0.462 / 0.47 Lift, 262 / 270 Adv. Duration

<sup>1</sup> **P5155596** Camshaft, Hydraulic, 0.464 / 0.464 Lift, 268 / 276 Adv. Duration

<sup>1</sup> **P5155592** Camshaft, Hydraulic, 0.477 / 0.48 Lift, 268 / 280 Adv. Duration

<sup>1</sup> **P5155593** Camshaft, Hydraulic, 0.488 / 0.491 Lift, 274 / 286 Adv. Duration

<sup>1</sup> **P5155594** Camshaft, Hydraulic, 0.507 / 0.51 Lift, 284 / 296 Adv. Duration

See chart for additional information.



B.



C.



D.

## CAMSHAFTS, LIFTERS, AND HARDWARE

## A. Camshafts, High Performance, Mechanical



A.

<sup>1</sup> P5155601	Camshaft, Mechanical, 0.488 / 0.501 Lift, 268 / 274 Adv. Duration
<sup>1</sup> P5155602	Camshaft, Mechanical, 0.502 / 0.511 Lift, 274 / 280 Adv. Duration
<sup>1</sup> P5155603	Camshaft, Mechanical, 0.52 / 0.54 Lift, 282 / 290 Adv. Duration
<sup>1</sup> P5155604	Camshaft, Mechanical, 0.54 / 0.558 Lift, 290 / 298 Adv. Duration
<sup>1</sup> P5155605	Camshaft, Mechanical, 0.55 / 0.57 Lift, 286 / 296 Adv. Duration
<sup>1</sup> P5155606	Camshaft, Mechanical, 0.567 / 0.579 Lift, 294 / 299 Adv. Duration
<sup>1</sup> P5155607	Camshaft, Mechanical, 0.59 / 0.609 Lift, 302 / 311 Adv. Duration
<sup>1</sup> P5155608	Camshaft, Mechanical, 0.65 / 0.63 Lift, 305 / 320 Adv. Duration
<sup>1</sup> P5155609	Camshaft, Mechanical, 0.65 / 0.65 Lift, 324 / 324 Adv. Duration
<sup>1</sup> P5155610	Camshaft, Mechanical Roller, 0.564 / 0.57 Lift, 274 / 280 Adv. Duration
<sup>1</sup> P5155611	Camshaft, Mechanical Roller, 0.57 / 0.576 Lift, 280 / 286 Adv. Duration
<sup>1</sup> P5155612	Camshaft, Mechanical Roller, 0.576 / 0.582 Lift, 286 / 292 Adv. Duration
<sup>1</sup> P5155613	Camshaft, Mechanical Roller, 0.582 / 0.588 Lift, 292 / 297 Adv. Duration
<sup>1</sup> P5155615	Camshaft, Mechanical Roller, 0.625 / 0.625 Lift, 306 / 306 Adv. Duration
<sup>1</sup> P5155616	Camshaft, Mechanical Roller, 0.657 / 0.659 Lift, 308 / 315 Adv. Duration
<sup>1</sup> P5155614	Camshaft, Mechanical Roller, 0.66 / 0.66 Lift, 283 / 291 Adv. Duration
<sup>1</sup> P5155617	Camshaft, Mechanical Roller, 0.66 / 0.663 Lift, 316 / 321 Adv. Duration

See chart for additional information.

## CAMSHAFTS, LIFTERS, AND HARDWARE

## BIG BLOCK HIGH PERFORMANCE CAMSHAFTS

Mopar Part Number	Valve Setting		RPM Operating Range	DURATION				VALVE LIFT		LOBE SEP ANGLE	Notes
	Intake	Exhaust		ADVERTISED		@ .050"		W/ 1.6 ROCKER			
				IN.	EX.	IN.	EX.	IN.	EX.		
<b>XTREME ENERGY™ Hydraulic Flat Tappet Camshafts</b>											
P5155589	Hyd.	Hyd.	600 to 4800	250	260	206	212	.432	.444	110°	Very strong torque excellent mileage, smooth idle.
P5155590	Hyd.	Hyd.	1000 to 5200	256	268	212	218	.447	.455	110°	Strong torque through low end and mid-range, good idle.
P5155591	Hyd.	Hyd.	1300 to 5600	262	270	218	224	.462	.470	110°	Excellent response, good mileage, stock converter, 3.23 gear.
P5155592	Hyd.	Hyd.	1600 to 5800	268	280	224	230	.477	.480	110°	Great for street machines, slightly rough idle works with stock converter.
P5155593	Hyd.	Hyd.	1800 to 6000	274	286	230	236	.488	.491	110°	High performance street. Very strong mid-range with headers, 2200+ stall.
P5155594	Hyd.	Hyd.	2300 to 6500	284	296	240	246	.507	.510	110°	Street/strip, needs 2800+ stall, 9:1 compression, rough idle.
P5155595	Hyd.	Hyd.	2800 to 6800	294	306	250	256	.519	.524	110°	Pro Street/bracket, good intake, headers, gear, 3200+ stall.
<b>MAGNUM MUSCLE Hydraulic Flat Tappet Camshafts (Today's Version Of Yesterday's Muscle Car Cams)</b>											
P5155596	Hyd.	Hyd.	1600 to 5600	268	276	222	226	.464	.464	110°	Factory I.D. #2895206 for: * 383c.i. 1968-70 factory 335 hp. * 383c.i. 1971 factory 300hp. * 440c.i. 1967-70 factory 375/390. * 440c.i. 1971 factory 370/383
<b>XTREME ENERGY™ Retro-Fit Hydraulic Roller Camshafts</b>											
P5155597	Hyd.	Hyd.	1800 to 5800	274	282	224	230	.538	.534	110°	3.55-4.10 gear, 2000 stall in 440, 2200+ in 383, 9:1 compression, high performance street.
P5155598	Hyd.	Hyd.	2200 to 6000	280	288	230	236	.541	.537	110°	3.91+ gear, 2500+ stall, 9.5:1 compression, aftermarket intake, headers.
P5155599	Hyd.	Hyd.	2500 to 6200	286	294	236	242	.544	.541	110°	3.91+ gear, 9.5:1+ compression, 2800+ stall, needs headers, rough idle.
P5155600	Hyd.	Hyd.	2800 to 6400	292	300	242	248	.549	.544	110°	4.10 gear, 3000+ stall, 10:1 compression, very rough idle, Pro Street/bracket race applications.
<b>XTREME ENERGY™ Solid Mechanical Flat Tappet Camshafts</b>											
P5155601	.016	.018	1800 to 5800	268	274	230	236	.488	.501	110°	Excellent for street and mild strip, 2200+ stall or 4 speed.
P5155602	.016	.018	2200 to 6200	274	280	236	242	.502	.511	110°	Serious street/strip, 9.5:1 compression with 2800+ stall. Strong mid-range.
P5155603	.016	.018	2500 to 6500	282	290	244	252	.520	.540	110°	Very strong mid and upper rpm power. 10:1 compression with 3000+ stall.
P5155604	.016	.018	3200 to 7000	290	298	252	260	.540	.558	110°	Max effort street/bracket race cam. 10.5:1 compression, 3500+ stall and low gears.
<b>DRAG RACE Solid Mechanical Flat Tappet Camshafts</b>											
P5155605	.018	.020	3500 to 6500	286	296	256	266	.550	.570	108°	Good bracket cam. 10.5:1+ compression, 3500+ stall in 440, 3800+ in 383.
P5155606	.018	.020	3800 to 6800	294	299	264	270	.567	.579	108°	Best with 11:1 compression in 383 with 4500+ stall, 4200+ stall with 440. Strong mid-range.
P5155607	.018	.020	4500 to 7200	302	311	274	282	.590	.609	108°	Good Super Street, Super Gas or bracket cam. Best with 12:1 compression in 440 with 5000+ stall or 5600+ stall in 383.
P5155608	.020	.022	5000 to 7500	305	320	279	287	.650	.630	110°	Good Super Street, Super Gas or bracket cam. Best in 470+ engines with 12:1 compression and 5500 stall.
P5155609	.028	.030	5000 to 7200	324	324	290	290	.650	.650	108°	440 with 5000+ stall, 513 gear, 11:1+ compression, 850+ CFM carb.
<b>XTREME ENERGY™ Mechanical Street Roller Camshafts</b>											
P5155610	.016	.018	2000 to 6000	274	280	236	242	.564	.570	110°	Best all around street roller. 9.5:1 compression with 2500+ stall.
P5155611	.016	.018	2500 to 6200	280	286	242	248	.570	.576	110°	9.5:1 with 3000+ stall. Strong mid-range with a lopey idle.
P5155612	.016	.018	3000 to 6500	286	292	248	254	.576	.582	110°	Serious street/strip effort, 10:1 compression with 3200+ stall.
P5155613	.016	.018	3500 to 6600	292	297	254	260	.582	.588	110°	Strong mid to upper rpm power, 10.5:1 compression with 3500+ stall. Radical idle.
<b>DRAG RACE Mechanical Roller Camshafts</b>											
P5155614	.026	.028	3500 to 6300	283	291	252	263	.660	.660	108°	Super strong low end torque. Best with 10.5:1 compression and single plane intake. 3500+ stall in 440, 3800 in 383.
P5155615	.028	.030	4000 to 7000	306	306	273	273	.625	.625	108°	383 Super Gas Super Street, 12:1+ compression, 5000+ stall.
P5155616	.026	.028	4500 to 7000	308	315	275	282	.657	.659	108°	Good Super Gas, Super Street with 12:1 compression and 850+ CFM carb. 5000+ stall with 440, 5400+ with 383.
P5155617	.026	.028	4800 to 7200	316	321	283	288	.660	.663	108°	Fast Bracket, Super Gas or Super Comp. Best with 12.5:1 compression and ported iron or aftermarket heads. 5500+ stall in 440.

## CAMSHAFTS, LIFTERS, AND HARDWARE

## A. Camshafts, Purple Shaft, Hydraulic

Mopar Performance cams are designed and engineered exclusively for your engine. A wide range of profiles is available from mild to wild and bracket to all-out racing. All Mopar Performance cams are designed, developed, dyno'd and track tested by engineers. These cams are developed for increased power and rpm potential while maintaining reliability and the best possible low-speed characteristics, including torque and idle quality. These Purple Shaft cams offer the best horsepower-to-dollar-spent value. Each cam package contains the cam, tappets and instruction sheet.

- <sup>1</sup> P4452783AC Camshaft, Hydraulic, 268/284 Adv. Duration
- <sup>1</sup> P4529270AC Camshaft, Hydraulic, 268/284 Adv. Duration
- <sup>1</sup> P4286677AC Camshaft, Hydraulic, 272/272 Adv. Duration
- <sup>1</sup> P4452993AC Camshaft, Hydraulic, 280/280 Adv. Duration
- <sup>1</sup> P4120235AC Camshaft, Hydraulic, 284/284 Adv. Duration
- <sup>1</sup> P5007697AC Camshaft, Hydraulic, 284/284 Adv. Duration
- <sup>1</sup> P4120237AC Camshaft, Hydraulic, 292/292 Adv. Duration
- <sup>1</sup> P5007698AC Camshaft, Hydraulic, 292/292 Adv. Duration
- <sup>1</sup> P4120659AC Camshaft, Mechanical, 284/284 Adv. Duration
- <sup>1</sup> P4120661AC Camshaft, Mechanical, 296/296 Adv. Duration
- <sup>1</sup> P4120663AC Camshaft, Mechanical, 312/312 Adv. Duration
- <sup>1</sup> P4349268AC Camshaft, Mechanical, 324/324 Adv. Duration

See chart for additional information.

Note: For flat tappet camshafts, Mopar recommends the use of a high zinc oil for maximum durability.



A.

# BIG BLOCK

## CAMSHAFTS, LIFTERS, AND HARDWARE

### A. Camshafts, Purple Shaft, Mechanical

- <sup>1</sup> P4120659AC Camshaft, Mechanical, 284/284 Adv. Duration
- <sup>1</sup> P4120661AC Camshaft, Mechanical, 296/296 Adv. Duration
- <sup>1</sup> P4120663AC Camshaft, Mechanical, 312/312 Adv. Duration
- <sup>1</sup> P4349268AC Camshaft, Mechanical, 324/324 Adv. Duration

See chart for additional information.

### B. Camshaft Sprocket Attaching Hardware

- P6030269 Bolt, Camshaft Sprocket, For One-Bolt Mounting, 426 Hemi/Big Block, Sold Individually
- P5007801 Bolt, Camshaft Sprocket, For Three-bolt Mounting, 426 Hemi/Big Block, Set of three
- P2120930 Bolt, Camshaft, Sprocket, For Three-Bolt Mounting, 383/440/426, Sold Individually



A.



B.

## BIG BLOCK PURPLE SHAFT CAMSHAFTS

Part No.	Advertised Duration	@ 0.050"	O-Lap	Center Line	Lift	Recom Spring	Basic RPM	Applications & Comments
<b>Hydraulic Camshafts</b>								
P4452783AC	268/284	228/241	46	115	0.450/0.458	P3690933	Idle-5800	Resto, 383/440 Magnum Super Commando Road Runner One Bolt Pattern
P4529270AC	268/284	228/241	46	115	0.450/0.458	P3690933	Idle-5800	Resto, 440 Six Pak (1969-71) Three Bolt Pattern
P4286677AC	272/272	231/231	48	112	0.455/0.455	—	1300-5700	Street One Bolt Pattern
P4452993AC	280/280	238/238	60	110	0.474/0.474	P3690933	2000-5900	Street/Strip One Bolt Pattern
P4120235AC	284/284	241/241	68	108	0.484/0.484	P3690933	2200-5900	Street/Strip One Bolt Pattern
P5007897AC	284/284	241/241	56	114	0.484/0.484	P3690933	2200-5900	Revised Center Line for Improved Street driveability One Bolt Pattern
P4120237AC	292/292	248/248	76	108	0.509/0.509	P5249848	2600-6000	Street/Strip One Bolt Pattern
P5007698AC	292/292	248/248	64	114	0.509/0.509	P5249848	2600-6000	Revised Center Line for Improved Street driveability One Bolt Pattern
<b>Mechanical Camshafts</b>								
P4120659AC	284/284	241/241	60	112	0.528/0.528	P5249848	2400-6600	Street/Strip Three Bolt Pattern
P4120661AC	296/296	252/252	76	110	0.557/0.557	P2806077	3000-6700	Street/Strip Three Bolt Pattern
P4120663AC	312/312	265/265	104	106	0.590/0.590	P2806077	3400-6900	Strip Three Bolt Pattern
P4349268AC	324/324	275/275	112	106	0.620/0.620	P4876064	4000-7000	Strip Three Bolt Pattern

Valve lash is listed in thousandths, for example .028", lash settings are "cold."





A.



B.



C.



D.



E.



F. P4876392



F. P4876391

## CAMSHAFTS, LIFTERS, AND HARDWARE

## A. Offset Camshaft Bushing Set

Set includes five bushings: 2°, 4°, 6°, 8° offset, and one on-center bushing. Color guide only — check installations with dial indicator. Gold = 2°, Copper = 4°, Silver = 6°, Black = 8°

**P3690936** Bushing Set, Camshaft, Offset, 426 Hemi/ Big Block/ Slant Six

## B. Hydraulic Tappet

Sold individually.

**P4006767** Tappet, Hydraulic, Hemi/ Big Block

## C. Mechanical Tappet

Sold individually.

**P2843177** Tappet, Mechanical, 0.0005" Undersize

## D. Roller Tappet Set

Includes matched pair of roller tappets with guide bar.

**P4452920** Tappet, Roller, for Bushed Lifter Bores, Hemi/Big Block, Set

## E. Pushrods, Mechanical- Hydraulic

Engineered to be installed in your engine rebuilding project. Pushrods are 3/8" diameter and are sold as complete engine sets or individually for service.

**P4529559** Pushrod, Hydraulic, 9.31" Length, "RB" Engine, Set of 16

**P4529545** Pushrod, Hydraulic, 9.31" Length, "RB" Engines, Sold Individually

**P4529560** Pushrod, Mechanical, 9.20" Length, Ball and Cup Style, "RB" Engine, Set of 16

**P4529546** Pushrod, Mechanical, 9.20" Length, Ball and Cup Style, "RB" Engine, Sold Individually

## F. Pushrods, Mechanical/Hydraulic

Special pushrods to use with adjustable rocker arms and hydraulic tappet cams.

**P4876392** Pushrod, Mechanical/Hydraulic, "RB" Engines, Set of 16

**P4876391** Pushrod, Mechanical/Hydraulic, "RB" Engines, sold individually

## BIG BLOCK

### CYLINDER HEADS, GASKETS, AND HARDWARE

#### A. Cylinder Heads, Aluminum

Head casting number 452 is complete with valves and springs (2.14" intake and 1.81" exhaust). Flow is 290 cfm intake and 217 cfm exhaust at .600" lift. These ready-to-bolt-on Heads use a straight plug design so you can use stock exhaust manifolds or many popular aftermarket headers. 361 and 440 Engines

- <sup>1</sup> P5153524 Cylinder Head, Aluminum, Includes Valves and Springs, Straight Plug, 84cc, 2.14" Intake / 1.81" Exhaust, "B/RB" Engines

#### B. Cylinder Heads, Stage V

Replaces stock cylinder head. Same as 1968-78 casting and chamber.

- <sup>1</sup> P4529993 Cylinder Head, Cast Iron, 90cc, 2.14" Intake, 1.81" Exhaust, Wedge, Stage V

#### C. Cylinder Heads, Stage VI

- <sup>1</sup> P4529335 Cylinder Head, Aluminum, 2.14" Intake, 1.81" Exhaust, Stage VI

- <sup>1</sup> P4876383 Cylinder Head, Aluminum, CNC-Ported, Stage VI, 2.18" Intake, 1.81" Exhaust

- <sup>1</sup> P4876386 Cylinder Head, Aluminum, CNC-Ported, Stage VI, 2.25" Intake, 1.81" Exhaust, Max Wedge

#### D. Cylinder Heads, Stage VII

These heads have a flow rate of 325 cfm intake, 226 cfm exhaust, at .700" lift.

- <sup>1</sup> P5153823 Cylinder Head, Aluminum, Max Wedge, Raised Port, Stage VII, 75cc, Angled Plug, 2.20" Intake, 1.81" Exhaust, 290cc Intake, 100cc Exhaust, B/RB.

- <sup>1</sup> P5153654 Cylinder Head, Aluminum, Wedge, Raised Port, Stage VII, 75cc, Angled Plug, 2.20" Intake, 1.81" Exhaust, 280cc Intake, 100cc Exhaust, B/RB

See chart for additional information.



A. P5153524



B. P4529993



C. P4529335



C. P4876386



D. P5153823



D. P5153654

### BIG BLOCK CYLINDER HEADS

Part Number	Design Type	Head / Assembly	Material	Chamber	Valve Sizes	Approx. Weight	Description
P5153524	452	Assembly	Aluminum	84 cc	2.14/1.81	25	Complete assembled head, straight spark plug design
P5007494	Max Wedge	Head	Cast iron	86 cc	2.08/1.88	50	Max Wedge III with revised ports — Cast pedestal, 6-bolt valve cover (approved for NHRA Stock and Super Stock)
P5249824	Max Wedge	Head	Cast iron	86 cc	2.14/1.81	50	Max Wedge III — Cast pedestal (not legal for Stock/Super Stock)
P5153654	Raised Port	Head	Aluminum	75 cc	2.20/1.81	25	Raised port design, angle spark plug, 280 cc Intake, 100 cc Exhaust
P5153823	Raised Port	Head	Aluminum	75 cc	2.20/1.81	25	Raised max wedge port design, angle spark plug, 290 cc Intake, 100 cc Exhaust
P4529993	Stage V	Head	Cast iron	90 cc	2.14/1.81	50	Replaces Stock — Same as 1968–78 casting and chamber
P4529335	Stage VI	Head	Aluminum	78 cc	2.14/1.81	25	Bare machined casting with bronze guides
P4876386	Stage VI	Head	Aluminum	N/A	2.25/1.81	25	CNC ported with Max Wedge port — use 2.25" intake and 1.81" exhaust valves
P4876383	Stage VI	Head	Aluminum	N/A	2.18/1.81	25	CNC ported with standard Stage VI port — use roller tappet cam with lifts over 0.600"

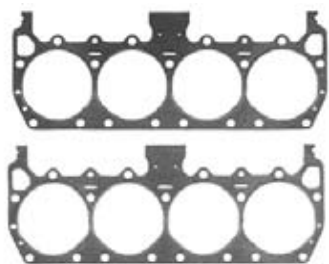

A.

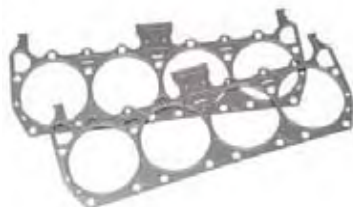

B.



C.



D.



E.



F.



G.

## CYLINDER HEADS, GASKETS, AND HARDWARE

### A. Cylinder Head Gaskets, Composite

Thick composite material gaskets (0.040" to 0.042", unless otherwise noted) can be used for replacement or competition applications up to 12.5:1 compression ratio. Sold as an engine set.

**P4349559** Gasket, Cylinder Head, Composite Material, Up to 4.380" Bore

### B. Cylinder Head Gaskets, Steel

**P5155236** Gasket, Cylinder Head, Multi Layer Steel, 0.025" Thick, B/RB Wedge, Individual

**P5155237** Gasket, Cylinder Head, Multi-Layer Steel, 0.025" Thick, B/RB Wedge, Engine Set

**P4286754** Gasket, Cylinder Head, Single Layer Production Style, 0.020" Thickness, Engine Set

### C. Head Bolt Set

Includes all required head bolts.

**P4120472** Bolt Set, Cylinder Head, 7/16"

### D. Porting Templates

Die cut clear templates take the guesswork out of porting a set of heads. Use to increase intake and exhaust flow as well as torque and horsepower.

**P4120437** Porting Template, 2.08"/1.74" Valve Size, Cast Iron Head, Big Block Production Heads

## VALVE COVERS AND HARDWARE

### E. Valve Covers, Cast Aluminum, Black Wrinkle

High-strength Cast Aluminum Valve Covers are more rigid than stamped steel, offering better anti-leak properties. Mopar Pentastar logo is cast into each cover. Set includes two valve covers, two oil filler caps, and baffle package.

**P5007614** Valve Cover, Cast Aluminum, Black Wrinkle, Set

### F. Valve Covers, Aluminum, "As Cast"

Sold "as cast," so you can set up the breathers the way you want them, and there's no paint to remove if welding is done. Mopar Pentastar logo is cast into each cover. Cast covers are more rigid than stamped steel which helps prevent valve cover leaks. Set includes two valve covers and oil filler caps.

**P5007615** Valve Cover, Aluminum, "As Cast," Set

### G. Valve Covers, Cast Aluminum, Polished

Polished to a chrome-like shine that's perfect for that show car engine look. Features Mopar Pentastar logo. Set includes two valve covers and two oil filler caps (does not include baffling).

**P5007616** Valve Cover, Cast Aluminum, Polished, Set

## BIG BLOCK

### VALVE COVERS AND HARDWARE

#### A. Valve Covers, Chrome, Direct Connection

P4349633AB Valve Covers, Chrome, Direct Connection, Big Block, Set

#### B. Valve Covers, Fabricated Aluminum

P5155526 Valve Cover, Aluminum, Wedge, Big Block, Set

#### C. Gaskets, Valve Cover

P4120101 Gasket, Valve Cover, Production Material, Set

P5155509 Gasket, Valve Cover, Reusable, B/RB Eng.

P4452091 Gasket, Valve Cover, Rubber Reinforced Cork. For Cast Valve Covers, Set

#### D. Baffle and Screw Package

For cast aluminum valve covers only.

P5007052 Baffle and Screw Package, Big Block/ Small Block/ Truck Magnum/Jeep Engines

#### E. Valve Cover Hardware

For stamped steel valve covers only. Accessory kit includes 12 chrome-plated screws and washers, one chrome-plated oil filter cap and two rubber grommets.

P4120272 Valve Cover Accessory Set, Big Block or Small Block

P5007419 Grommet and Plug Set, Valve Cover, Big Block or Small Block

P5007458 Bolt Set, Valve Cover, Chrome, Big Block/Small Block, 12 Pieces

P4349620 Washer Package, Chrome, 12 Pieces

#### F. Valve Cover Retaining Screw Set

Includes 12 black Retaining Screws. For cast aluminum valve covers only.

P5007053 Retaining Screw, Valve Cover, Big Block/Small Block

#### G. Grommet Set, Cast Aluminum Valve Covers

Includes two grommets. For cast aluminum valve covers only.

P5007921 Grommet, Knockout, Die-Cast Valve Cover, Set

#### H. Breather Caps, Chrome

For use with Mopar cast aluminum valve covers to fill extra valve cover holes. Push-in-style Breather Cap requires the use of Grommet Set P4529882.

P4529881 Breather Cap, Push-In Style, Chrome

P4529880 Breather Cap, Twist-On, Bottom Vented, Chrome

P4529882 Grommet, Rubber, Use with Breather Cap P4529881



A. P4349633AB



B.

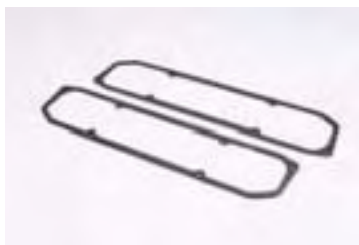

C. P4452091



D.



E.



F.



G.



H. P4529880

## VALVES AND VALVE TRAIN HARDWARE

## A. Valves

These stainless steel Valves have swirl-polished underheads that have no flat or ski jump areas. Each features a 3/8" stem diameter and one square groove.

- <sup>1</sup> P5249201 Valve, Exhaust, 1.74" Diameter, 4.87" Stem Length
- <sup>1</sup> P5249202 Valve, Exhaust, 1.81" Diameter, 4.87" Stem Length
- <sup>1</sup> P4876398 Valve, Exhaust, 1.88" Diameter, 4.87" Stem Length
- <sup>1</sup> P5249199 Valve, Intake, 2.08" Diameter, 4.86" Stem Length
- <sup>1</sup> P5249200 Valve, Intake, 2.14" Diameter, 4.86" Stem Length
- <sup>1</sup> P5249866 Valve, Intake, 2.18" Diameter, 4.86" Stem Length
- <sup>1</sup> P4876396 Valve, Intake, 2.20" Diameter, 4.86" Stem Length



A.

## B. Valve Seals

Made of high-temp Viton material, these Valve Seals feature a full or semi-umbrella shape for best dual-purpose use. Helps prevent oil seepage down valve guides. Not recommended for use with dual valve springs. Sold in sets of 16.

- <sup>1</sup> P4120492 Valve Seals, 3/8" Stem, Big Block/ Small Block



B.

## C. Valve Stem Lash Caps

These Lash Caps are 0.080" thick and fit between the end of the valve and the rocker arm tip. They are made of hardened steel for improved rocker tip durability. Larger area than stock valve tip to help spread the rocker loads. Sold in sets of 16.

- <sup>1</sup> P4120626 Lash Caps, Valve Stem, 3/8" Stem, A/B/RB Engines



C.

## D. Valve Keepers (Split Locks)

These single-groove-style Valve Keepers are made from hardened material. They feature a 3/8" stem diameter and can be used for restoration or performance applications. Sold as cylinder head sets of 16 pieces. Note that two sets are required for all V8 engines.

- <sup>1</sup> P4120618 Valve Keepers, 7°, Single Groove
- <sup>1</sup> P4286612 Valve Keepers, 10°, Single Groove



D.

Questions? Call the Mopar Direct Connection Techline at 1-888-528-HEMI (4364)

<sup>1</sup> Not legal on pollution-controlled vehicles or vehicles registered for highway use.

## BIG BLOCK

### VALVES AND VALVE TRAIN HARDWARE

#### A. Valve Springs

High-pressure Valve Springs can be used on exhaust and intake valves for all high-performance applications. They feature a shorter fully compressed height and allow for increased valve lift. Springs maintain spring load at higher rpms. A must for high-performance cams. Sold individually.

- <sup>1</sup> P4286812 Valve Spring, Single, 0.430"/0.460" Lift
- <sup>1</sup> P3690933 Valve Spring, Single, 0.440"/0.500" Lift
- <sup>1</sup> P5249848 Valve Spring, Single, 0.480"/0.540" Lift
- <sup>1</sup> P2806077 Valve Spring, Double, 0.500"/0.610" Lift
- <sup>1</sup> P4876064 Valve Spring, Double, 0.590"/0.640" Lift

See chart for additional information.

#### B. Valve Spring Retainers

Available in two levels of performance: Chrome Moly for restoration and heavy-duty applications and Titanium for top-level race performance. Sold individually.

- P4452033 Retainer, Chrome Moly, 3/8", Single, Std Height, 7°
- P4529288 Retainer, Chrome Moly, 5/16", Single/Dual, Std Height, 7°
- P4452769 Retainer, Steel, 5/16", Single, Std Height, 7°
- P4120785 Retainer, Titanium, 3/8", Dual, Std Height, 10°
- P4286775 Retainer, Titanium, 3/8", Triple, .060" Increase, 10°

### ROCKER ARMS, SHAFTS, SUPPORTS, AND HARDWARE

#### C. Rocker Arm Sets, Aluminum, Race

Includes 16 Rockers and two Shafts, appropriate spacers and assembly lube. Extruded high strength aluminum body. Roller tip to reduce internal friction and improve geometry. Adjustable with lock nut. Use with raised port heads P5153654 and P5153823.

- <sup>1</sup> P5153900 Rocker Arm Set, 1.6 ratio, 0.565" Offset Intake



A.



A.



B.



B.



C.

### BIG BLOCK VALVE SPRINGS

Part Number	Installed Ht.	Description	OD	Wire Diameter	Lift Range	Material	Retainers
P4286812	1.83"/1.86"	Single/damper	1.49"	0.208"	0.430"/0.460"	Chrome Vanadium	P4452033
P3690933	1.83"/1.86"	Single/damper	1.53"	0.224"	0.440"/0.500"	Chrome Vanadium	P4452769, P4529288, P5007858
P5249848	1.86"/1.87"	Single/damper	1.55"	0.216"	0.480"/0.540"	Chrome Silicon	P4452769, P4289288
P2806077	1.83"/1.86"	Dual/damper	1.52"	0.215"	0.500"/0.610"	Chrome Vanadium	P4529288, P4120785
P4876064	1.86"/1.88"	Dual/damper	1.60"	0.216"	0.590"/0.640"	Chrome Silicon	P4529288, P4120785
P4007536	2.00"/2.02"	Triple	1.62"	0.225"	0.640"/0.745"	Chrome Silicon	P4286775
P5249849	2.00"/2.02"	Dual/damper	1.55"	0.216"	0.650"/0.750"	Chrome Silicon	P4120785

1. All valve springs are sold individually.

2. With a single spring, the damper is installed inside the main spring; with a dual spring, the damper is installed between the inner and outer springs. There is no damper in the triple springs.

3. Retainers listed are the basic recommendation. Check the actual retainer listing for other options-added installed height, materials, lock size.

## ROCKER ARMS, SHAFTS, SUPPORTS, AND HARDWARE

## A. Rocker Shafts

P4529101 Rocker Shaft, Hydraulic Valve Gear, On-Center, Sold Individually



A.



B.

## B. Rocker Shaft End Plugs

Sold as a set of four. These do not fit aftermarket rocker shafts.

P5249633 Rocker Shaft End Plugs, 426 Hemi/Big Block

## C. Rocker Shaft Hold-Down

Billet Aluminum Rocker Shaft Hold-Downs provide greater rocker shaft stiffness, which helps rocker shaft maintain roundness when torque is applied. Roundness is important with mechanical rockers and high spring loads. Anodized blue.

P5249714 Rocker Shaft Hold-Down

## D. Rocker Shaft Retainers and Bolts

Package contains previously hard-to-find hold down retainers and bolts necessary to secure both rocker shafts. Manufactured to Mopar original equipment specifications to assure high quality. For use on all cylinder heads with cast-in rocker stands.

P4529744 Rocker Shaft Retainers and Bolts



C.



D.

## E. Rocker Shaft Stands

Heavy-duty billet aluminum CNC-machined Rocker Shaft Stands for standard rocker shafts and rocker arms.

P5007217 Rocker Shaft Stand, Max Wedge I, II and P4529996

P5007742 Rocker Shaft Stand, Stage VI CNC Ported Heads P4876383 and P4876386



E.

Questions? Call the Mopar Direct Connection Techline at 1-888-528-HEMI (4364)

<sup>1</sup> Not legal on pollution-controlled vehicles or vehicles registered for highway use.

## BIG BLOCK

### INTAKE MANIFOLDS, HARDWARE, AND GASKETS

#### A. Single Plane Intake Manifolds

Engineered for use with standard cylinder heads. Requires no attaching modifications. Perfect for Bracket, Super Stock, or general high-performance applications. Offers a 5-10 horsepower advantage over other single plane manifolds. Carburetor flange accepts standard Holley four-barrel carburetor.

- <sup>1</sup> P4529724 Intake Manifold, Aluminum, Single Plane, 4500 Carb., 361/383/400 with Stage IV, V, or Production Heads
- <sup>1</sup> P4529725 Intake Manifold, Aluminum, Single Plane, 4500 Carb., 413/426W/440 with Stage IV, V, or Production Heads
- <sup>1</sup> P4529462 Intake Manifold, Aluminum, Single Plane, Four-barrel Carburetor, 361/383/400 with Stage IV, V, or Production Heads
- <sup>1</sup> P4529463 Intake Manifold, Aluminum, Single Plane, Four-barrel Carburetor, 413/426W/440 with Stage IV, V, or Production Heads

#### B. Single Plane Intake Manifolds- Race

- <sup>1</sup> P4876337 Intake Manifold, Aluminum, Single Plane, Race, 4150-Style Carburetor, "RB", Max Wedge, Stock Cylinder Heads
- <sup>1</sup> P4876129 Intake Manifold, Aluminum, Single Plane, Race, 4500 Carburetor, "RB", Max Wedge Stage VI Heads
- <sup>1</sup> P4876128 Intake Manifold, Aluminum, Single Plane, Race, Four-barrel Carburetor, "RB", Max Wedge Stage VI Heads

#### C. Dual Plane Intakes - Six Pack

- <sup>1</sup> P4529055 Intake Manifold, Aluminum, Dual Plane, Six Pack, 361/383/400 with Stage IV, V, or Production Heads
- <sup>1</sup> P4529056 Intake Manifold, Aluminum, Dual Plane, Six Pack, 413/426W/440 with Stage IV, V, or Production Heads

#### D. Cross Ram Intake Manifold- Max Wedge

After 40 years, Mopar is pleased to bring back the Cross Ram Max Wedge Intake Manifold! This brand-new design improves airflow by as much as 20% and is fully interchangeable on all Max Wedge applications. It is based on the 1964 Max Wedge intake and uses production and aftermarket-style AFB carburetors. Designed for "RB" engines with Max Wedge heads. Uses P5153567 Linkage Package.

- <sup>1</sup> P5007330 Intake Manifold, Aluminum, Cross Ram, Dual 4-bbl Carbs, Max Wedge and "RB" Engines, Use Bolt Kit P5153338.



A.



B.



C.



D. P5007330





A. P5249433



B.



C.



D.

## INTAKE MANIFOLDS, HARDWARE, AND GASKETS

### A. Intake Manifold Gaskets

Custom-fit set comes complete to service one engine. Includes gaskets, end seals, O-rings, and distributor seal (where applicable).

- P5249483 Gasket, Intake Manifold, 0.030" Thick, Big Port with Stage VI Heads, Set
- P5249433 Gasket, Intake Manifold, 0.030" Thick, Big Block with Stage VI Heads, Set
- P5249467 Gasket, Intake Manifold, 0.045" Thick, Big Block with Stage VI Heads, Set
- P5249484 Gasket, Intake Manifold, 0.045" Thick, Big Port with Stage VI Heads, Set
- P5249485 Gasket, Intake Manifold, 0.060" Thick, Big Port with Stage VI Heads, Set
- P5249643 Gasket, Intake manifold, 0.060" Thick, Composite Material, Max Wedge
- P5155129 Gasket, Intake Manifold, Stock RB Wedge, Set

### B. Intake Manifold Gasket Heat Block-Off

Stainless steel Intake Manifold Gasket Heat Block-Off keeps exhaust heat from transferring to the intake manifold for a cooler, denser fuel-air mixture.

- P4286825 Gasket, Heat Block-Off, Intake Manifold, "B" Engines
- P4286826 Gasket, Heat Block-Off, Intake Manifold, "RB" Engines
- P4452103 Gasket, Heat Block-Off, Intake Manifold, 361/383/400 with Stage IV, V, or Production Heads, Race, Set
- P4452105 Gasket, Heat Block-Off, Intake Manifold, 413/426W/440 with Stage IV/V, or Production Heads, Race, Set

### C. Intake Manifold Hardware

- P5249926 Plug Package, Intake Manifold, Cross Ram, Hemi and Max Wedge. Includes eight intake manifold plugs.
- P5153338 Hardware Kit, Max Wedge Cross Ram Intake Manifold P5007330, Includes bolts and plugs

## OILING COMPONENTS

### D. Oil Pans

Includes factory engineered and approved oil pan, drain plug and washer. Center sump style is used on passenger car applications, while the rear sump style is used for pickups. Windage Trays may be used if desired. See the Oil Pickup and Screen Assemblies for specific application information. Listed quart capacity is with filter installed.

- P5155628 Oil Pan, Five-Quart, Center Sump, RB Engines
- P5249064AB Oil Pan, Six-Quart, Rear Sump
- P5007807AB Oil Pan, Six-Quart, Center Sump, Stock Style, Must Use Oil Pickup P5007848, Stamped
- P5007816 Oil Pan, Eight-Quart, Center Sump, Hemi/Big Block

## BIG BLOCK

### OILING COMPONENTS

#### A. Oil Pan Bolt Set

**P4120613** Bolt Set, Oil Pan, 426 Hemi, Big Block/ Small Block, Set of 20 Bolts

#### B. Oil Pan Gaskets

For Big Block and Hemi® applications. Note that two are required for Windage Tray applications.

**P4452099** Gasket, Oil Pan, Race, Set of Two

**P3412049** Gasket, Oil Pan, Sold Individually

#### C. Oil Pickup and Screen Assemblies - Eight-Quart

Factory original reissued oil pickup and screen assemblies. Standard pickups are 3/8", race-style requires hole enlargement in stock blocks.

**P5007818** Oil Pickup and Screen Assembly, Eight-Quart, 1/2" Pipe, Use with Oil Pan P5007816

**P5007817** Oil Pickup and Screen Assembly, Eight-Quart, 3/8" Pipe, Use with Oil Pan P5007816

#### D. Oil Pickup and Screen Assemblies - Six-Quart

Factory original reissued Oil Pickup and Screen Assemblies. Standard pickups are 3/8", while race styles require hole enlargement in stock blocks. P4529564 does not fit the 440 Six Pak.

**P5249817** Oil Pickup and Screen Assembly, Six-Quart, 1/2" Pipe, "B" Engines

**P5249818** Oil Pickup and Screen Assembly, Six-Quart, 1/2" Pipe, Siamese Bore, Not Raised Cam, 426 Hemi and Big Block

**P4529564** Oil Pickup and Screen Assembly, Six-Quart, 3/8" Pipe, "B" Engines

**P4529565** Oil Pickup and Screen Assembly, Six-Quart, 3/8" Pipe, "RB" Engines

**P5007848** Oil Pickup and Screen Assembly, Six-Quart, 3/8" Pipe, Use with Oil Pan P5007807AB

#### Oil Pickup Adapters (Not Shown)

For new replacement Wedge blocks with bolt-on pickup bosses. Use when running 1/2" oil pickup. Replaces stock 3/8" boss.

**P5155063** Oil Pick Up Adapter, 3/8", Wedge

**P5155064** Oil Pick Up Adaptor, 1/2", Wedge

#### E. Oil Pressure Relief Spring

Increases engine oil pressure over stock spring for high-performance applications. Delivers up to 70 lbs. of oil pressure. Includes cap and instructions.

**P4286571** Spring, Oil Pressure Relief, B/RB/Hemi



A.

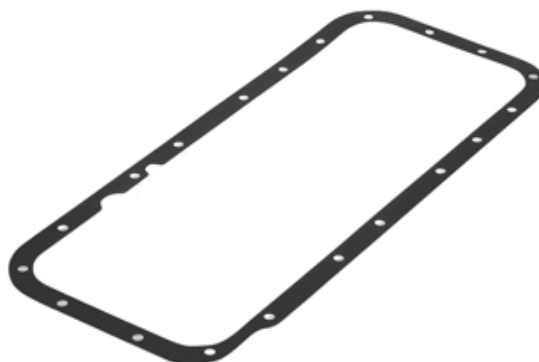

B.



C/D.



E.



A.



B.



C.



D.



E.



F.



G.

## OILING COMPONENTS

### A. Valley Trays

Keeps engine oil in the tappet chamber and off the intake manifold.

**P4876847** Valley Tray, "B" Engines, w/Stage VI Heads

**P4876848** Valley Tray, "RB" Engines

**P5153821AB** Valley Tray, Engines with Raised Port P5153654 or P5153823 Heads, For "B" Blocks

**P5153822AB** Valley Tray, Engines with Raised Port P5153654 or P5153823 Heads, For "RB" Blocks

### B. Windage Trays

Designed to provide improved engine lubrication by reducing interior windage at higher engine speed. Package includes tray and two pan gaskets.

**P4120998** Windage Tray, 3.75" Stroke

**P5007345** Windage Tray, 4.15" Stroke

### C. Oil Pump Assembly

Provides a 25% increase in oil volume. Ideal replacement for stock pump in high-performance applications.

**P4286590** Oil Pump Assembly, Use With 02084355 Service Gasket

### D. Distributor Drive Gear Assemblies

Features a hardened tip shaft with full radius blend from hex to round and pinned gears.

**P3571071** Distributor Drive Gear, Flat Tappet Cams

**P3412064** Distributor Drive Gear, Flat Tappet Cams, Milodon Oil System

**P3690875** Distributor Drive Gear, Roller Tappet, Aluminum-Bronze Gear

**P3690876** Distributor Drive Gear, Roller Tappet, Aluminum-Bronze Gear, Milodon Oil System

### E. Dipstick and Tube, Chrome

**P4349629** Dipstick and Tube, Chrome, Big Block

### F. Oil Filter- Performance

Engineered to meet the demands of heavy-duty and high-performance applications. Black with Mopar Pentastar logo.

**P4452890** Oil Filter, High-Performance, Black Finish, 6/8 Cylinder Engines

### G. Oil Filter - Race

High-performance, heavy-duty race oil filter has a thicker canister with high burst strength. Black with Mopar Pentastar logo.

**P4529190** Oil Filter, Race, Black Finish, 426 Hemi, Big Block, Small Block

## BIG BLOCK

### OILING COMPONENTS

#### A. Oil Filter- Restoration

Mopar has reissued these service replacement oil filters, used in the 1960s and 1970s. The white filter was used from the 1960s throughout the '70s. The high-performance white filter (P4529805) was recommended for use in competition from 1965 to 1974. The black filter was used from the late 1950s through the early 60s. These filters may not fit some V8 applications (those after 1972 requiring short filters).

- P4529806** Oil Filter, Restoration, Black with Yellow Mopar logo, 1962-66 V8
- P4529805** Oil Filter, Restoration, High-Performance, White with Red Stripe



A. P4529805



B.

### COOLING SYSTEMS

#### B. Oil Pump Priming Shaft

Don't fire up that engine without pre-lubing (priming) it thoroughly with oil. Special hardened steel shaft fits on any 3/8" or larger drill. Insert shaft into hole where distributor fits. Pressurizes oil galleries to ensure against dry starts and engine damage. Fits all V8 engines.

- P4286800** Shaft, Oil Pump Priming

#### C. Water Pump

Fully assembled and ready to install. Features an eight-blade impeller. Dimensions are same as stock cast iron version.

- P5007643AB** Water Pump, Aluminum, B/RB/ Hemi



C.



D.

#### D. Water Pump Housing

Lightweight aluminum water pump housing. More than eight pounds lighter than typical production cast iron housing. Has dual alternator bracket mounting bosses, so it fits all "B" and "RB" engines, 1958-74.

- P4286900** Water Pump Housing, Aluminum, B/RB/ Hemi

Note: Radiator hose inlet is on the driver's side, so it cannot be used on 1973-up vehicles that have the hose on the passenger side.

#### E. Water Pump Installation Kit

Includes water pump gasket, pump housing gasket, plugs, water pump screws, plus long and short housing screws.

- P5007449** Water Pump Installation Kit



E.



F.

#### F. Thermostat Housing, Chrome

This high-quality Chrome Thermostat Housing is made of heavy-duty material. Includes gasket and two chrome bolts.

- P4286759** Water Neck, Chrome, Up To 1978, V8

#### G. Bolt Set, Water Pump Housing, Chrome

Engine chrome dress-up projects are incomplete without chrome bolts.

- P5007621** Bolts, Water Pump, Chrome



G.

## COOLING SYSTEMS

**A. 90 Degree Water Neck Outlet**

Cast aluminum 90° Thermostat Housing provides greater flexibility in routing cooling system hoses and improves the appearance of the engine compartment. Features three-direction capability - ideal for compact engine compartments.

**P5249191** Thermostat Housing, 90 Degrees



A.

**B. Thermostat**

Heavy-duty Thermostat can handle increased heat management duties in high-performance engines. Replacement gasket included.

**P4876307** Thermostat, 180 Degree, 426 Hemi/Big Block/Small Block/Slant Six Engines, Up to 1978



B.

**C. Viscous Fan Package**

Most late 1960s and early 1970s factory-built muscle cars were equipped with viscous fans for cooling purposes. This package provides thermostatically controlled cooling, and includes a lightweight balanced fan. Offers up to 15 horsepower gain on typical high-performance V8s.

**P4120758** Viscous Fan Package, 18" fan. 3.25 Pitch



C.

Questions? Call the Mopar Direct Connection Techline at 1-888-528-HEMI (4364)

<sup>1</sup> Not legal on pollution-controlled vehicles or vehicles registered for highway use.





P  
R  
I  
O  
R  
I  
T  
Y  
I  
S  
S  
U  
E

## SMALL BLOCK

### CRATE ENGINES

#### A. 440 Super Commando Crate Engine - 530 Horsepower

Big block power and cubic inches in a small block package! Mopar's 440 Super Commando small block stroker crate engine gives you over 500 horsepower on pump gas, and offers the compact size of a small block.

<sup>1</sup> P5153523 Crate Engine, 440 Super Commando, 530 Horsepower, 540 ft.-lbs. Torque

Specifications:

- Bore: 4.185"
- Stroke: 4.000"
- Compression Ratio: 10:1
- Block: 340 Siamese Block with Four-bolt Mains
- Cylinder Heads: Aluminum
- Intake Manifold: Single Plane Four-barrel
- Camshaft: Hydraulic, 251°/257° Duration @ .050", .603" Lift
- Oil Pan: Eight-quart Center Sump Street/Strip Oil Pan
- Crankshaft: Forged 4340
- Pistons: Forged
- Valves: 2.080"/1.600" Stainless, w/ 5/16" Stems
- Connecting Rods: Forged 6.123"
- Rocker Arm: Aluminum Roller with 1.6:1 Ratio

Note: Crate engines that change the emissions performance of the vehicle may not be legal for use on vehicles regulated for highway use in California and other states. Horsepower and torque ratings based on test engine. Ratings may vary on individual engines.

#### B. 410 Six Pack Crate Engine - 470 Horsepower

Nothing shrinks time and distance like cubic inches and a good induction system. Mopar's new 410 Stroker Small-Block has all the goods for whatever your application is. Basic ingredients include a new 340 block featuring 4-bolt mains, aluminum "LA" heads, high-lift hydraulic camshaft and a 4.00" Stroker heavy-duty forged crankshaft. Topped off with a sexy aluminum "Six Pack" intake manifold and Mopar cast aluminum valve covers. The 410 has the right stuff to impress the troops at the drag strip and on cruise nights.

<sup>1</sup> P5153527 Crate Engine, 410 Six Pack, 470 Horsepower, 490 ft.-lbs. Torque

Specifications:

- Bore: 4.040"
- Stroke: 4.000"
- Compression Ratio: 10:1
- Block: New 340 Replacement Block with Four-bolt Mains
- Cylinder Heads: Aluminum "LA" Heads
- Intake Manifold: Aluminum "Six Pack"
- Camshaft: Hydraulic, 292°/292° Duration; .508" Lift
- Oil Pan: Eight-quart Center Sump Street/Strip Oil Pan

Note: Shown with available carburetors P4349237 Center and P4349238 Outboard (not included).

Note: Crate engines that change the emissions performance of the vehicle may not be legal for use on vehicles regulated for highway use in California and other states. Horsepower and torque ratings based on test engine. Ratings may vary on individual engines.



A. Shown with carburetor and air cleaner, not included



B. Shown with carburetors, not included



## CRATE ENGINES

## A. 360 Magnum Crate Engine - 405 Horsepower

Mopar offers a high output Magnum 360, now standard with new aluminum Magnum cylinder heads. Mopar testing produced 405 horsepower at 5,900 rpm, with peak torque output of 400 ft.-lbs. at 4,600 rpm. Mopar recommends the use of a 750 cfm Holley carburetor (P4349228) and 1-7/8" exhaust headers (not available through Mopar).

<sup>1</sup> P5155074 Crate Engine, 360 Magnum, 405 Horsepower, 400 ft.-lbs. Torque

## Specifications:

- New HP Magnum Block
- New Aluminum Magnum Cylinder Heads
- Mopar Cast Aluminum Valve Covers
- High-Strength Stainless Steel Valves - 2.02" Intake, 1.60" Exhaust
- Heavy-Duty Valve Springs
- Hydraulic Roller Camshaft - 288°/292° Advertised Duration
- Pistons - 10:1 C.R.
- Single Plane, M1® 4-bbl Aluminum Intake Manifold  
(Includes Bosses for MPI Conversion; Taller than Stock - Check Hood Clearance)
- Center Sump Oil Pan Similar to Commando Engine  
(Fits Passenger Cars; Pan Swap Required for Truck Use)
- Mopar Performance Electronic Ignition Kit with Distributor
- Heavy-Duty Engine Stand and Engine Crate
- Does Not Include Accessory Brackets
- Not for Use with Air Conditioning
- Not Recommended for Factory MPI Replacement
- Flex Plate P4876706 and a Symmetrical, Neutrally Balanced Torque Converter or Flywheel P5249842 Are Recommended (Not Included)

Note: Uses premium fuel. Crate engines that change the emissions performance of the vehicle may not be legal for use on vehicles regulated for highway use in California and other states. Horsepower and torque ratings based on test engine. Ratings may vary on individual engines.



A. P5155074

## SMALL BLOCK

### CRATE ENGINES

#### A. 340 Six-Pack Crate Engine - 330 Horsepower

The new 340 crate engine is built with all new parts, including a 340 block with four-bolt mains, Aluminum "LA" cylinder heads, HD cast crankshaft, six-pack intake, ignition system, water pump and stock-style front sump oil pan that will fit in most muscle cars.

<sup>1</sup> P5153526 Crate Engine, 340 Six-pack, 330 Horsepower, 330 ft-lbs Torque

##### Specifications:

- Bore: 4.040"
- Stroke: 3.310"
- Compression Ratio: 10:1
- Block: New 340 Replacement Block with Four-bolt Mains
- Cylinder Heads: Aluminum "LA"
- Intake Manifold: Aluminum Six Pack
- Camshaft: Hydraulic (292°/292° Duration, 0.508" Lift)
- Oil Pan: Stock Style Center Sump - Fits Most Muscle Cars

Note: Shown with Available Carburetors - P4349241 Center, P4349239 Outboard (not included).

Note: Crate engines that change the emissions performance of the vehicle may not be legal for use on vehicles regulated for highway use in California and other states. Horsepower and torque ratings based on test engine. Ratings may vary on individual engines.

### BLOCKS

#### Long Block Assemblies (Not Shown)

<sup>1</sup> P5153947 Block, Long Assembly, 5.9L/360 Magnum



A. Shown with carburetors, not included

## BLOCKS

## A. Short Block Assemblies

These Short Block Assemblies are built with all-new components including block, crankshaft, connecting rods, pistons and camshaft bearings. Does not include camshaft, timing cover or timing set.

- <sup>1</sup> P5153907 Block, Short Assembly, 4.000" Bore, 3.580" Stroke, 5.9L Magnum/ 360 "LA"
- <sup>1</sup> P5153908 Block, Short Assembly, 4.040" Bore, 3.310" Stroke, 340 "LA"
- <sup>1</sup> P5153909 Block, Short Assembly, 4.040" Bore, 4.000" Stroke, 410 "LA", Stroker 340
- <sup>1</sup> P5153910 Block, Short Assembly, 4.185" Bore, 4.000" Stroke, 440 "LA", Stroker 340

See chart for additional information.

Note: Short Block Assemblies that change the emissions performance of the vehicle may not be legal for use on vehicles regulated for highway use in California and other states.



A.



A.

## MAGNUM / "LA" SHORT BLOCKS

Part Number	Displacement	Block Type	Deck Height	Bore	Stroke	Crankshaft	Piston	Rods	Comp Height	Comp Ratio/ CC Size
P5153907	360	Magnum/ "LA"	9.6	4.000"	3.58"	Cast	Cast	Forged 6.123"	1.667"	9:1 w/ 60cc
P5153908	340	"LA"	9.6	4.040"	3.31"	Cast	Cast	Forged 6.123"	1.840"	10:1 w/ 63cc
P5153909	410	"LA"	9.6	4.040"	4.00"	Forged	Forged	Forged 6.123"	1.450"	10:1 w/ 63cc
P5153910	440	"LA"	9.6	4.185"	4.00"	Forged	Forged	Forged 6.123"	1.350"	10:1 w/ 63cc

Questions? Call the Mopar Direct Connection Techline at 1-888-528-HEMI (4364)

<sup>1</sup> Not legal on pollution-controlled vehicles or vehicles registered for highway use.

## SMALL BLOCK

### BLOCKS

#### A. HP Magnum and "LA" Blocks

Magnum and "LA" Blocks are designed for general high performance use and entry level racing.

Features:

- Ready for assembly without the need for any additional machining
- Bored and honed to standard bore size
- Camshaft Bearings and freeze plugs installed in block
- Hardware kit included
- Ductile Iron Main Caps with ARP bolts (four-bolt on the center three caps)
- Dual motor mounts with "LA" and Magnum mounts (must use late 1970s 318 mount for left side)
- Heavy duty casting with thicker deck and bore walls
- Works with all stock-style engine components
- P5153452 & P5153579 work with Magnum stock-style Hydraulic Roller Camshafts (requires tappet retainer kit P5155275)
- Not recommended for use with aftermarket tie bar style mechanical roller tappets
- Siamese Bore (all except P5007552AB) - allows up to 4.220" bore size
- Standard deck height - 9.600"
- Setup for wet sump oiling system with oil drain holes in the valley
- Magnum blocks can also be used for "LA" applications with dual oiling system provisions (LA oil passages to heads or Magnum oiling through pushrods, and flat tappet or hydraulic roller cams)
- MPI provisions for Magnum crank trigger
- 59° Tappet Bore - works with all stock-style cylinder heads and camshafts
- P5153579 requires use of 318/340 "LA" oil pan (stock 5.2L Magnum oil pan will not fit)

<sup>1</sup> P5153478AB Block, Cast Iron, 340 Replacement, Siamese-bore, 4.040" Finished Bore

<sup>1</sup> P5007552AB Block, Cast Iron, 340, Non-Siamese-bore, 4.040" Finished Bore

<sup>1</sup> P5153743 Block, Cast Iron, Race, 340 Replacement, Siamese-bore, 4.175" Rough Bore

<sup>1</sup> P5153579 Block, Cast Iron, Race, 5.2L Magnum/318 "LA", Siamese-bore, 3.910" Finished Bore

<sup>1</sup> P5153452 Block, Cast Iron, Race, 5.9L Magnum/360 "LA", Siamese-bore, 4.000" Finished Bore

See chart for additional information.

Note: P5153478AB is not legal for NHRA Stock Eliminator race applications. Use P5007552AB.



A. P5007552AB

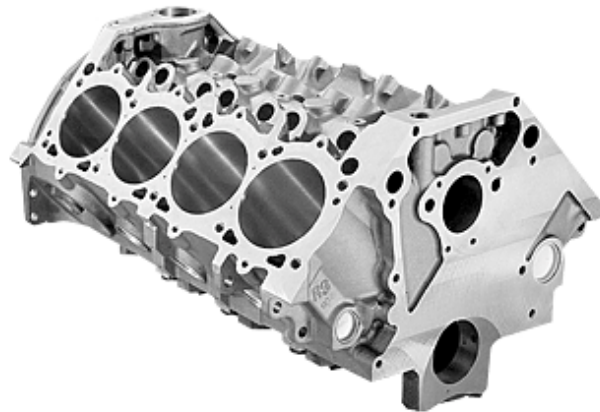

A.

#### SMALL BLOCK ENGINE DISPLACEMENT\*

Stroke	Bore										
	3.910"	3.940"	3.970"	4.000"	4.030"	4.040"	4.060"	4.100"	4.125"	4.180"	4.220"
3.31"	318	323	328	333	338	340	343	350	354	363	370
3.58"	344	349	355	360	365	367	371	378	383	393	401
3.79"	364	370	375	381	387	389	392	400	405	416	424
4.00"	384	390	396	402	408	410	414	422	427	439	448
4.25"	408	414	421	427	433	436	440	449	454	466	476

\* Cubic Inches

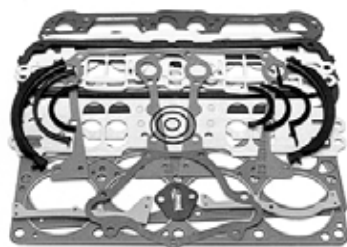

A.



B.



C.



D.



E.



F.

## ENGINE BLOCK HARDWARE

### A. Engine Teardown Gaskets

Engine Teardown Gasket Set includes all gaskets needed for complete engine teardown: oil pan, cylinder head, valve cover, timing chain case cover, intake manifold and oil pump gaskets.

- P4120692 Gasket, Engine Teardown, 340/360 Small Block
- P4876248 Gasket, Engine Teardown, 5.2L Magnum Jeep/Truck
- P4876249 Gasket, Engine Teardown, 5.9L Magnum Jeep/Truck

### B. Engine Bearing

Two sets are required for complete engine installation. Comes with narrow #5 Main Bearing- Std. size H-Series bearing with 1/2 groove. race use only.

- P5153513 Main Bearings, Standard, 318/340

### C. Block Hardware Package

Includes all the necessary dowels, plugs, bushings, and keys, as well as core plugs, rear cam bearing plug, drive gear bushing, head dowels and oil filter plate (with gasket and fitting).

- P5249261AB Hardware Package, Block, (oil filter plate and gasket will not fit 1965-'92 273/318/340/360 "LA" engines- use Mopar part numbers - plate 2402103, and gasket 04897939AA)

### D. Brass Core Plugs

Round, press-in engine block Brass Core Plugs will never rust and fit standard or Mopar race cast iron blocks.

- P5249706 Freeze Plugs, Brass

### E. Front Cover Gasket

For 5.2L/5.9L Dodge Truck Magnum and Jeep engines.

- P4876052 Gasket, Front Cover, 5.2L/5.9L Dodge Truck Magnum/Jeep Engines

## CRANKSHAFTS AND HARDWARE

### F. Forged Crankshafts

Surface hardened, Forged Crankshafts feature radiused fillets at main and rod journals, six-bolt flange, 4340 steel. Requires balancing. 4.00" stroke cranks require clearancing on block.

- <sup>1</sup> P5007253 Crankshaft, Forged, 3.58" Stroke, 318/340 Main
- <sup>1</sup> P5007255 Crankshaft, Forged, 3.58" Stroke, 360 Main
- <sup>1</sup> P5007252 Crankshaft, Forged, 4.00" Stroke, 318/340 Main
- <sup>1</sup> P5007254 Crankshaft, Forged, 4.00" Stroke, 360 Main

## SMALL BLOCK

### CRANKSHAFTS AND HARDWARE

#### A. Cast Crankshafts

Special heavy-duty Cast Crankshafts with radiused fillets. Features six-bolt pattern on crank flange. Requires balancing. 4.00" stroke cranks require clearancing on block.

- <sup>1</sup> P5007257 Crankshaft, Cast Iron, 3.58" Stroke, 318/340 Main
- <sup>1</sup> P5007259 Crankshaft, Cast Iron, 3.58" Stroke, 360 Main Small Block, 5.9L Magnum Jeep/Truck
- <sup>1</sup> P5007256 Crankshaft, Cast Iron, 4.00" Stroke, 318/340 Main
- <sup>1</sup> P5007258 Crankshaft, Cast Iron, 4.00" Stroke, 360 Main Small Block, 5.9L Magnum Jeep/Truck

#### B. Crank Bolt Set

Heavy-duty bolts used to attach the vibration damper to the crankshaft.

- P5249557AB Bolt Set, Crank, 2.25" Length, 426 Hemi/ Big Block/ Small Block/ Aftermarket Dampers

#### C. Crank Key Package

Used to locate the crankshaft sprocket on the nose of the crankshaft. Contains two keys.

- P5249822 Key Package, Crank, 426 Hemi/ Big Block/ Small Block/ Slant Six

### VIBRATION DAMPERS

#### D. Vibration Damper- SFI Approved

Features a steel ring and a universal front pulley mount pattern.

- <sup>1</sup> P5249690 Vibration Damper, Steel, 1967-91 273/318 Small Block, 1968-71 340 Small Block Forged Crank

#### E. Vibration Damper

Production-style Crank Vibration Damper is designed for all production-balanced Small Block engines. Not SFI-approved.

- <sup>1</sup> P5007187AB Vibration Damper, 5.9L Truck Magnum/Jeep Engines, 360 Magnum Crate Engines
- <sup>1</sup> P5007301 Vibration Damper, Externally Balanced, 1971-92 360 "A" Engines, pre-Magnum Short Blocks P4876907 and P4876908
- <sup>1</sup> P4452816 Vibration Damper, Internally Balanced, 1967-91 273/318, 1968-early 1972 340 Forged Crank

#### F. Damper Degree Timing Tape

Improve timing accuracy with this Damper Degree Timing Tape. Marked in 90° increments. Self-adhesive strip adheres to the Crank Vibration Damper for clear identification of marks. Permits reading up to 60° instead of only 10°-15° as on chain case timing tab.

- P4529070AB Damper Degree Timing Tape



A.



B.



C.



D.



E.



F. Damper Not Included



A.



B/C.



D.



E.



F.



G.

## VIBRATION DAMPERS

### A. Oil Slinger

Protects front seal from excessive oil contact. Forces lubricant oil into chain.

P5249636 Oil Slinger, 426 Hemi/ Big Block/ Small Block/ Slant Six/ 3.9L V6

## TIMING CHAIN AND SPROCKETS

### B. All-Out Race Chain and Sprockets

Matched sprockets and double roller chain for all-out race applications. Kits feature three matched keyways to adjust cam timing. Includes magna-fluxed sprockets and roller timing chains.

<sup>1</sup> P4876559 Chain and Sprockets, 0.005" Oversize, Race

<sup>1</sup> P5249131 Chain, Double, Roller, Replacement, Cloyes Race Application

### C. Double Roller Chain and Sprocket

High-strength Double Roller Chain provides added durability and decreased rotational friction versus production silent chain.

<sup>1</sup> P5249131 Chain, Double, Roller, Replacement, Cloyes Race Application

<sup>1</sup> P5249267 Chain, Double, Roller, with Sprockets, One-bolt Mount, Three Matched Keyways, Small Block, 5.2L/5.9L Magnum/Jeep Engines

### D. Timing Chain Tensioner

Stabilizes cam timing by reducing timing chain slack. Can be used in place of thrust plate (P5249637).

<sup>1</sup> P5007709 Timing Chain Tensioner, Small Block/ 3.9L/ 5.2L/ 5.9L Truck/Magnum/Jeep Engines

### E. Front Cover Seal and Gasket

P4876280 Seal, Front Cover, 426 Hemi/ Big Block/ Small Block

P4876700 Gasket, Front Cover, for Short Deck Race Blocks (9.00"-9.20"), use with Covers P4876631-32

### F. Timing Chain Covers

<sup>1</sup> P5249930AB Cover, Timing Chain, Production, Includes Seal and Gasket, 9.600" Deck, Small Block and V6

<sup>1</sup> P4876632 Cover, Timing Chain, Sand Cast, Race, 9.00"-9.20" Deck, Race Water Pump/Front Motor Plate

### G. Bolt Set, Chrome, Front Timing Cover

Package includes a complete set of chrome bolts for timing chain covers.

P4529256 Bolt Set, Chrome, Water Pump, 1969-92 "A" Engine

## SMALL BLOCK HIGH PERFORMANCE CAMSHAFTS

Mopar Part Number	Valve Setting		RPM Operating Range	DURATION				VALVE LIFT		LOBE SEP ANGLE	Notes
				ADVERTISED		@ .050"		W/ 1.6 ROCKER			
	Intake	Exhaust		IN.	EX.	IN.	EX.	IN.	EX.		
<b>XTREME ENERGY™ Hydraulic Flat Tappet Camshafts</b>											
P5155541	Hyd.	Hyd.	800 to 4800	250	260	206	212	.432	.444	110°	Very strong torque excellent mileage, smooth idle.
P5155542	Hyd.	Hyd.	1000 to 5200	256	268	212	218	.447	.455	110°	Strong torque through low end and mid-range, good idle.
P5155543	Hyd.	Hyd.	1300 to 5600	262	270	218	224	.462	.470	110°	Excellent response, good mileage, stock converter, 3.23-4.10 gear
P5155544	Hyd.	Hyd.	1600 to 5800	268	280	224	230	.477	.480	110°	Great for street machines, largest cam for stock converter, 273-318 works best with 2000 stall.
P5155545	Hyd.	Hyd.	1800 to 6000	274	286	230	236	.488	.491	110°	Very strong torque and throttle response, 2200+ stall.
P5155546	Hyd.	Hyd.	2300 to 6500	284	296	240	246	.507	.510	110°	Street/strip, needs 3000+ stall, headers, gears, rough idle.
P5155547	Hyd.	Hyd.	3000 to 7000	294	306	250	256	.519	.524	110°	Pro Street/bracket, good intake, headers, gear, 3500+ stall.
<b>MAGNUM MUSCLE Hydraulic Flat Tappet Camshafts (Today's Version Of Yesterday's Muscle Car Cams)</b>											
P5155548	Hyd.	Hyd.	1800 to 5800	268	276	222	226	.464	.464	110°	Factory I.D. #2893206 for: * 340c.i., 1968-71, factory 275 hp. * 340c.i., 1970, factory 290 hp.    * 340c.i., 1972-73, factory 240 hp
<b>DRAG RACE Hydraulic Flat Tappet Camshafts</b>											
P5155549	Hyd.	Hyd.	3500 to 6500	305	305	253	253	.525	.525	110°	Needs 4000+ stall. Headers, manifold, 750 CFM.
<b>XTREME ENERGY™ Retro-Fit Hydraulic Roller Camshafts</b>											
P5155550	Hyd.	Hyd.	1400 to 5500	268	276	218	224	.535	.531	110°	3.23-3.91 gears, stock converter in 340 and 360, mild converter in 318, 9:1 compression, street machine.
P5155551	Hyd.	Hyd.	1800 to 5800	274	282	224	230	.538	.534	110°	3.55-4.10 gears, 2200+ stall, 9:1 compression, headers, high performance street.
P5155552	Hyd.	Hyd.	2200 to 6000	280	288	230	236	.541	.537	110°	3.91+ gears, 9.5:1 compression, 2500+ stall, aftermarket intake, headers.
P5155553	Hyd.	Hyd.	2500 to 6200	286	294	236	242	.544	.541	110°	3.91+ gears, 2800+ stall, 9.5:1 compression, needs headers rough idle, street strip.
P5155554	Hyd.	Hyd.	2800 to 6400	292	300	242	248	.548	.544	110°	4.10 gear, 3000+ stall, 10:1 compression, Pro Street applications, very rough idle.
<b>COMPUTER CONTROLLED Hydraulic Roller Camshafts (1985-92 w/ Shaft Rockers &amp; Mech. Fuel Pump, Long Snout)</b>											
P5155555	Hyd.	Hyd.	700 to 4800	254	262	199	206	.450	.450	112°	Best in a 318 Magnum engine. Good towing cam for Dakota P/U. This cam has oil holes and a long snout.
P5155556	Hyd.	Hyd.	800 to 5000	262	264	206	210	.450	.480	112°	Best in a 360 Magnum engine. Good towing cam for full size P/U. Good performance cam for Dakota. This cam has oil holes and a long snout, may require computer modifications.
P5155557	Hyd.	Hyd.	900 to 5200	264	274	210	220	.480	.480	112°	Best performance cam for 360 Magnum engine. This cam has oil holes and a long snout, will require computer modifications.
<b>COMPUTER CONTROLLED Hydraulic Roller Camshafts (1988-91 w/ Shaft Rockers &amp; Electric Fuel Pump, Short Snout)</b>											
P5155558	Hyd.	Hyd.	700 to 4800	254	262	199	206	.450	.450	112°	Factory replacement for fuel injected engines with shaft mounted rocker arms. Good torque cam in 318.
P5155559	Hyd.	Hyd.	800 to 5000	262	264	206	210	.450	.480	112°	Performance cam for 318. Good towing cam for 360. May require computer modifications.
P5155560	Hyd.	Hyd.	900 to 5200	264	274	210	220	.480	.480	112°	High performance cam for 360. Will require computer modifications.
<b>XTREME ENERGY™ Computer Controlled Hydraulic Roller Camshafts For 1992-02 Magnum Engines (WITH 1.6 ROCKERS)</b>											
P5155561	Hyd.	Hyd.	700 to 4800	258	264	206	212	.480	.480	112°	Super strong torque cam for 318, idle to 4500 rpm.
P5155562	Hyd.	Hyd.	1000 to 5000	264	270	212	218	.480	.480	114°	Strong towing cam for 360, performance cam for 318 with better exhaust and computer modifications.
P5155563	Hyd.	Hyd.	1200 to 5400	265	273	216	224	.506	.506	114°	Performance cam for 360. 1200-5400 rpm. Likes lower gears and exhaust. Will require computer modifications.
<b>COMPUTER CONTROLLED Hydraulic Roller Camshafts For 1992-02 Magnum Engines (WITH 1.6 ROCKERS)</b>											
P5155564	Hyd.	Hyd.	700 to 4800	254	262	199	206	.480	.480	112°	Factory replacement for 318 with strong torque.
P5155565	Hyd.	Hyd.	800 to 5000	262	264	206	210	.480	.512	112°	Performance street cam for 318. Excellent torque in 360. May require computer modifications.
P5155566	Hyd.	Hyd.	900 to 5200	264	274	210	220	.512	.512	112°	High performance cam for 360. Will require computer modifications.
<b>XTREME ENERGY™ Solid Mechanical Flat Tappet Camshafts</b>											
P5155567	.016	.018	2000 to 6000	268	274	230	236	.488	.501	110°	340-360 street/strip use. 9:1 compression with 2500 stall, strong mid-range.
P5155568	.016	.018	2200 to 6200	274	280	236	242	.502	.511	110°	Great for street machines and mild bracket racing, 9.5:1 compression with 2800 stall, lopy idle.
P5155569	.016	.018	2500 to 6500	282	290	244	252	.520	.540	110°	Serious street/strip effort, needs 10:1 compression, single plane intake and 3000 stall. Radical idle.



**SMALL BLOCK HIGH PERFORMANCE CAMSHAFTS (CONTINUED)**

Mopar Part Number	Valve Setting		RPM Operating Range	DURATION				VALVE LIFT		LOBE SEP ANGLE	Notes
	Intake	Exhaust		ADVERTISED		@ .050"		W/ 1.6 ROCKER			
				IN.	EX.	IN.	EX.	IN.	EX.		
<b>DRAG RACE Solid Mechanical Flat Tappet Camshafts</b>											
P5155570	.020	.022	3500 to 6500	281	299	252	262	.542	.555	106°	3500+ converter in 360 or 3800+ in 340. Needs single plane intake and 10.5:1 compression. Excellent low end and mid-range torque.
P5155571	.026	.028	4000 to 7000	290	290	255	255	.540	.540	106°	318-340. 4000+ stall 750 CFM, manifold. 4.88 gear. 10.5:1+ compression.
P5155572	.020	.022	4000 to 7000	290	304	260	266	.558	.555	106°	Best all around bracket cam. 4000+ converter in 360 or 4300+ stall in 340, min. compression ratio is 11:1.
P5155573	.018	.020	4300 to 7400	295	312	266	274	.570	.572	106°	4500 converter in 360 or 4800+ stall in 340, 11.5:1 compression.
P5155574	.018	.020	4500 to 7500	300	316	270	278	.579	.578	108°	Good Super Street or fast bracket cam. Works best with 12:1 compression and 5000+ converter.
<b>XTREME ENERGY Mechanical Roller Camshafts</b>											
P5155575	.016	.018	2000 to 6000	268	274	230	236	.552	.564	110°	Good for mild street/strip use with 9:1 compression and a 2500 stall. Noticeable idle.
P5155576	.016	.018	2200 to 6300	274	280	236	242	.564	.570	110°	Serious street/strip use. 9.5:1 compression with 2800+ stall. Lopey idle.
P5155577	.016	.018	2500 to 6500	280	286	242	248	.570	.576	110°	3000 stall with 10:1 compression, strong mid-range with a radical idle.
P5155578	.016	.018	2800 to 6800	286	292	248	254	.576	.582	110°	3300 + stall with 10:1 compression. Strong top end with a racey idle.
<b>DRAG RACE Mechanical Roller Camshafts</b>											
P5155579	.020	.022	4200 to 7400	296	303	263	270	.649	.651	106°	Good all around bracket cam. 4200+ stall in 360 or 4500+ stall in 340, 11.5:1 compression.
P5155580	.020	.022	4500 to 7500	302	309	269	276	.654	.655	106°	Good Super Street or bracket cam. 11.5:1 compression with 4500+ stall.
P5155581	.026	.028	4800 to 7800	308	317	275	284	.658	.661	108°	Good Super Gas or Fast Bracket cam. 12:1 compression with 5500+ stall.
P5155582	.026	.028	5500 to 8000	314	321	281	288	.661	.664	110°	Good Super Gas, Super Comp or Fast Bracket cam, medium to large cubic inch engines with 6000+ converter.

## SMALL BLOCK

### CAMSHAFTS, LIFTERS, AND HARDWARE

#### A. Camshafts, High Performance, Hydraulic

<sup>1</sup> P5155541	Camshaft, Hydraulic, 0.432 / 0.444 Lift, 250 / 260 Adv. Duration
<sup>1</sup> P5155542	Camshaft, Hydraulic, 0.447 / 0.455 Lift, 256 / 268 Adv. Duration
<sup>1</sup> P5155543	Camshaft, Hydraulic, 0.462 / 0.470 Lift, 262 / 270 Adv. Duration
<sup>1</sup> P5155548	Camshaft, Hydraulic, 0.464 / 0.464 Lift, 268 / 276 Adv. Duration
<sup>1</sup> P5155544	Camshaft, Hydraulic, 0.477 / 0.480 Lift, 268 / 280 Adv. Duration
<sup>1</sup> P5155545	Camshaft, Hydraulic, 0.488 / 0.491 Lift, 274 / 286 Adv. Duration
<sup>1</sup> P5155546	Camshaft, Hydraulic, 0.507 / 0.510 Lift, 284 / 296 Adv. Duration
<sup>1</sup> P5155547	Camshaft, Hydraulic, 0.519 / 0.524 Lift, 294 / 306 Adv. Duration
<sup>1</sup> P5155549	Camshaft, Hydraulic, 0.525 / 0.525 Lift, 305 / 305 Adv. Duration
<sup>1</sup> P5155555	Camshaft, Hydraulic Roller, 0.450 / 0.450 Lift, 254 / 262 Adv. Duration
<sup>1</sup> P5155558	Camshaft, Hydraulic Roller, 0.450 / 0.450 Lift, 254 / 262 Adv. Duration
<sup>1</sup> P5155556	Camshaft, Hydraulic Roller, 0.450 / 0.480 Lift, 262 / 264 Adv. Duration
<sup>1</sup> P5155559	Camshaft, Hydraulic Roller, 0.450 / 0.480 Lift, 262 / 264 Adv. Duration
<sup>1</sup> P5155564	Camshaft, Hydraulic Roller, 0.480 / 0.480 Lift, 254 / 262 Adv. Duration
<sup>1</sup> P5155561	Camshaft, Hydraulic Roller, 0.480 / 0.480 Lift, 258 / 264 Adv. Duration
<sup>1</sup> P5155562	Camshaft, Hydraulic Roller, 0.480 / 0.480 Lift, 264 / 270 Adv. Duration
<sup>1</sup> P5155557	Camshaft, Hydraulic Roller, 0.480 / 0.480 Lift, 264 / 274 Adv. Duration
<sup>1</sup> P5155560	Camshaft, Hydraulic Roller, 0.480 / 0.480 Lift, 264 / 274 Adv. Duration
<sup>1</sup> P5155565	Camshaft, Hydraulic Roller, 0.480 / 0.512 Lift, 262 / 264 Adv. Duration
<sup>1</sup> P4876348	Camshaft, Hydraulic Roller, 0.501 / 0.513 Lift, 230/234 Adv. Duration
<sup>1</sup> P5155563	Camshaft, Hydraulic Roller, 0.506 / 0.506 Lift, 265 / 273 Adv. Duration
<sup>1</sup> P5155566	Camshaft, Hydraulic Roller, 0.512 / 0.512 Lift, 264 / 274 Adv. Duration
<sup>1</sup> P5155550	Camshaft, Hydraulic Roller, 0.535 / 0.531 Lift, 268 / 276 Adv. Duration
<sup>1</sup> P5155551	Camshaft, Hydraulic Roller, 0.538 / 0.534 Lift, 274 / 282 Adv. Duration
<sup>1</sup> P5155552	Camshaft, Hydraulic Roller, 0.541 / 0.537 Lift, 280 / 288 Adv. Duration
<sup>1</sup> P5155553	Camshaft, Hydraulic Roller, 0.544 / 0.541 Lift, 286 / 294 Adv. Duration
<sup>1</sup> P5155554	Camshaft, Hydraulic Roller, 0.549 / 0.544 Lift, 292 / 300 Adv. Duration



A.

## CAMSHAFTS, LIFTERS, AND HARDWARE

## A. Camshafts, High Performance, Mechanical



A.

<sup>1</sup> P5155567	Camshaft, Mechanical, 0.488 / 0.501 Lift, 268 / 274 Adv. Duration
<sup>1</sup> P5155568	Camshaft, Mechanical, 0.502 / 0.511 Lift, 274 / 280 Adv. Duration
<sup>1</sup> P5155569	Camshaft, Mechanical, 0.520 / 0.540 Lift, 282 / 290 Adv. Duration
<sup>1</sup> P5155571	Camshaft, Mechanical, 0.540 / 0.540 Lift, 290 / 290 Adv. Duration
<sup>1</sup> P5155570	Camshaft, Mechanical, 0.542 / 0.555 Lift, 281 / 299 Adv. Duration
<sup>1</sup> P5155572	Camshaft, Mechanical, 0.558 / 0.555 Lift, 290 / 304 Adv. Duration
<sup>1</sup> P5155573	Camshaft, Mechanical, 0.570 / 0.572 Lift, 295 / 312 Adv. Duration
<sup>1</sup> P5155574	Camshaft, Mechanical, 0.579 / 0.578 Lift, 300 / 316 Adv. Duration
<sup>1</sup> P5155575	Camshaft, Mechanical Roller, 0.552 / 0.564 Lift, 268 / 274 Adv. Duration
<sup>1</sup> P5155576	Camshaft, Mechanical Roller, 0.564 / 0.570 Lift, 274 / 280 Adv. Duration
<sup>1</sup> P5155577	Camshaft, Mechanical Roller, 0.570 / 0.576 Lift, 280 / 286 Adv. Duration
<sup>1</sup> P5155578	Camshaft, Mechanical Roller, 0.576 / 0.582 Lift, 286 / 292 Adv. Duration
<sup>1</sup> P5155579	Camshaft, Mechanical Roller, 0.649 / 0.651 Lift, 296 / 303 Adv. Duration
<sup>1</sup> P5155580	Camshaft, Mechanical Roller, 0.654 / 0.655 Lift, 302 / 309 Adv. Duration
<sup>1</sup> P5155581	Camshaft, Mechanical Roller, 0.658 / 0.661 Lift, 308 / 317 Adv. Duration
<sup>1</sup> P5155582	Camshaft, Mechanical Roller, 0.661 / 0.664 Lift, 314 / 321 Adv. Duration

See chart for additional information.

## B. Camshafts, Purple Shaft, Hydraulic

All Mopar Purple Shaft performance camshafts are designed, developed, dyno'd and track-tested by engineers for increased power and rpm potential while maintaining reliability and the best possible low-speed characteristics, including torque and idle quality. Each package contains the camshaft, instruction sheet, and tappets.



B.

<sup>1</sup> P4452757AC	Camshaft, 0.410"/0.425" Lift, 248/256 Adv. Duration
<sup>1</sup> P4452782AC	Camshaft, 0.429"/0.444" Lift, 228/235 Adv. Duration
<sup>1</sup> P4452759AC	Camshaft, 0.430"/0.450" Lift, 260/268 Adv. Duration
<sup>1</sup> P4452761AC	Camshaft, 0.450"/0.455" Lift, 268/272 Adv. Duration
<sup>1</sup> P4452992AC	Camshaft, 0.474"/0.474" Lift, 280/280 Adv. Duration
<sup>1</sup> P4120231AC	Camshaft, 0.484"/0.484" Lift, 284/284 Adv. Duration
<sup>1</sup> P4120233AC	Camshaft, 0.508"/0.508" Lift, 292/292 Adv. Duration

Note: Mopar recommends the use of a high zinc oil for maximum durability for flat tappet camshafts.

## SMALL BLOCK

### CAMSHAFTS, LIFTERS, AND HARDWARE

#### A. Camshafts, Purple Shaft, Mechanical

All Mopar Purple Shaft performance camshafts are designed, developed, dyno'd and track-tested by engineers for increased power and rpm potential while maintaining reliability and the best possible low-speed characteristics, including torque and idle quality. Each package contains the camshaft, instruction sheet, and tappets.

<sup>1</sup> P4120653AC Camshaft, 0.528"/0.528" Lift, 284/284 Adv. Duration

<sup>1</sup> P4120655AC Camshaft, 0.557"/0.557" Lift, 296/296 Adv. Duration

<sup>1</sup> P4120657AC Camshaft, 0.590"/0.590" Lift, 312/312 Adv. Duration

See chart for additional information.

Note: Mopar recommends the use of a high zinc oil for maximum durability for flat tappet camshafts.

#### B. Camshafts, Roller UGL, Race

The 48° tappet "R" blocks (R1, R2, R3, R4) require special camshafts. These UGL (unground lobe) camshafts enable cam grinders to grind specific cam profiles to create a finished cam. Cannot be used in engine as is.

<sup>1</sup> P5007932 Camshaft, Roller, UGL, Race, Roller Tappets, for 50 mm Roller Bearings P4876707, "R" Blocks

<sup>1</sup> P5007437 Camshaft, Roller, UGL, Race, Roller Tappets, for 60 mm Roller Bearings P5007361, "R" Blocks

<sup>1</sup> P4876633 Camshaft, Roller, UGL, Race, Roller Tappets, for Babbitt Bearings P4876372, "R" Blocks

#### C. Camshaft Plate Kit

Designed to take the thrust of the camshaft. Includes the cam plate and all necessary bolts.

P5249637 Camshaft Plate Kit



A.



B.



C.

### SMALL BLOCK PURPLE SHAFT CAMSHAFTS

Part No.	Advertised Duration	@ 0.50"	O-Lap	Center Line	Lift	Recom. Spring	Basic RPM	Applications and Comments
<b>Hydraulic Camshafts</b>								
P4452757	248/256	211/218	32	110	0.410/0.425	P4286813	1000 – 5000	Drag mild comp and perf RV
P4452782	268/276	228/235	44	114	0.429/0.444	P4120249	Idle – 5800	Muscle car – factory original
P4452759	260/268	221/228	44	110	0.430/0.450	P4286813	1200 – 5200	Drag mild comp and high perf RV
P4452761	268/272	228/231	50	110	0.450/0.445	P4120249	1500 – 5800	Drag light comp and good mid-range
P4452992	280/280	238/238	60	110	0.474/0.474	P4120249	2000 – 6000	Drag mild comp w/ auto or 4 speed
P4120231	284/284	241/241	68	108	0.484/0.484	P4120249	2600 – 6000	Drag mod. comp w/ auto or 4 speed
P4120233	292/292	248/248	76	108	0.508/0.508	P5249847	2800 – 6200	Drag modified comp
P4529317	320/320	272/272	104	108	0.533/0.533	P5249847	3800 – 6400	Drag mod. comp w/ auto or 4 speed
<b>Mechanical Camshafts</b>								
P4120653	284/284	241/241	60	112	0.528/0.528	P5249847	2800 – 6900	Drag modified comp
P4120655	296/296	252/252	76	110	0.557/0.557	P3614542	3400 – 7200	Drag pro comp, man & high stall auto
P4120657	312/312	265/265	104	106	0.590/0.590	P3614542	4000 – 7500	Drag pro comp, auto. w/race conv.



A.



B.



C.



D.



E.



F.



G. P5153848



H.

## CAMSHAFTS, LIFTERS, AND HARDWARE

## A. Camshaft Sprocket Attaching Hardware

Required when a fuel pump eccentric is used.

- P2120930** Bolt, Camshaft, Sprocket, For Three-Bolt Mounting, 383/440/426, Sold Individually  
**P4529838** Hardware Package, Camshaft Sprocket

## B. Offset Camshaft Keys

For centerlining your camshaft, these hardened keys are color coded in 1°, 2°, 3°, 4° and 5° increments. Production key is used for zero offset.

- P5249600** Camshaft Keys, Offset, 3.7L/ 3.9L/ 4.7L/ 5.2L/ 5.9L Truck Magnum/Jeep Engines

Note: Color code for cam keys: Natural-1°, Red-2°, Blue-3°, Yellow-4°, White-5°

## C. Mechanical Tappet

Sold individually.

- <sup>1</sup> **P2843177** Tappet, Mechanical, 0.0005" Undersize

## D. Hydraulic Tappet

Sold individually.

- <sup>1</sup> **P3614321** Tappet, Hydraulic, 340 Engine

## E. Hydraulic Roller Tappets

- <sup>1</sup> **P4876054** Tappets, Hydraulic, Roller, 5.2L/5.9L Truck Magnum/Jeep Engines, Sold Individually  
<sup>1</sup> **P5249862** Tappets, Hydraulic, Roller, 5.2L/5.9L Truck Magnum/Jeep Engines, Magnum Crate, Set of 16  
<sup>1</sup> **P4876055** Tappet Aligning Yoke, 5.2L/5.9L Dodge Truck Magnum/Jeep Engines, Sold Individually

## F. Roller Tappet

Includes matched pair of Roller Tappets with guide bar.

- <sup>1</sup> **P4452919** Tappet Set, Roller, Not Recommended with "R" Blocks and 340 Replacement Blocks

## G. Pushrods

- <sup>1</sup> **P5153848** Pushrod Set, Required for Use With Aluminum Magnum Cylinder Head P5153847  
<sup>1</sup> **P5249662** Pushrods, Hydraulic, Roller, 6.92", 5.2L/5.9L Magnum/Jeep Engines/ Magnum Crate, Set of 16

## H. Dog Bones

- <sup>1</sup> **P5155275** Dog Bone Kit, For Hydraulic Roller Tappets on Magnum Race Blocks P5153452 AND P5153579, Includes 8 Dog Bones, Screws, Springs

## SMALL BLOCK

### CYLINDER HEADS, GASKETS, AND HARDWARE

#### A. Cylinder Heads, "LA"

Aluminum Assemblies, Requires Head Bolt Set P5153851.

- <sup>1</sup> P5153849 Cylinder Head, Aluminum, 63 cc Combustion Chamber, 2.020"/1.600" Valves With HP Springs, 1967-1992 "LA" 318/360 Engines
- <sup>1</sup> P5155639 Cylinder Head, Aluminum, Bare, Used in P5153849
- <sup>1</sup> P5153850 Cylinder Head, Super Commando, Aluminum, Machined and Assembled with 2.080" / 1.600" Valves (5/16" Stem) with HP Springs, Use Rocker Arm Set P5153995, "LA" Engines
- <sup>1</sup> P5155128 Cylinder Head, Aluminum, Super Commando, Bare, Used in P5153850

#### B. Cylinder Heads, Cast Iron, W2 Race

Features flat-machined rocker pads that require the use of T&D Race Rocker Arms and long valves. Heads must be oiled through the tappets and hollow pushrods. Older style rocker stands and rocker systems do not work with these heads.

- <sup>1</sup> P5007708AB Cylinder Head, Cast Iron, Race, 2.02" Intake, 1.60" Exhaust, 48° Tappet, 47cc Chamber, W2
- <sup>1</sup> P5007445AB Cylinder Head, Cast Iron, Race, 2.02" Intake, 1.60" Exhaust, 48° Tappet, 65 cc Chamber, W2
- <sup>1</sup> P5249769 Cylinder Head, Cast Iron, Race, 2.02" Intake, 1.60" Exhaust, 59° Tappet, 65cc Chamber, W2

#### C. Cylinder Heads, Raised Port, W9

Partially machined W9 Cylinder Head with raised intake and exhaust ports. Recommended for use in Sprint cars and Midget cars.

Features:

- High-strength, lightweight A356 aluminum alloy casting
- Ports raised significantly higher than standard W9 Cylinder Heads
- Machined deck, intake surface, head bolts and valve cover rail
- Ports are cast small to allow for flexibility in porting (requires porting)
- Chamber is cast filled in to allow very small machined chamber (requires machining)
- Requires machining for valve guides, spark plugs, intake screws, porting, valve spring pockets, rocker stands and injectors
- Recommended valve length: 6.040" intake and 6.060" exhaust
- Six-bolt head attachment design
- Recommended for use with T&D rocker arms with 0.750" offset (custom order)

- <sup>1</sup> P5007904AB Cylinder Head, Aluminum, Raised Port, with Extra Stiffening Ribs, Small Block, A4 Midget Block, W9RP



A. P5153849



A. P5153850



B.



C.

## CYLINDER HEADS, GASKETS, AND HARDWARE

### A. Cylinder Heads, Aluminum, W9

Designed with the professional racer in mind, W9 Aluminum Cylinder Heads incorporate the latest in "paperless design technology" to give racers the leading edge. Features high-strength, lightweight A356 aluminum alloy casting with thick decks that permit small chambers for maximum compression ratios, six-bolt head attachment design for sealing integrity, and raised intake and exhaust ports for maximum performance. Heads have a 15° valve angle, with additional material to permit "rolling" the head (except head P5007861 which is 13°). They are the same length as the block to permit ease of installation with engine plates.

- <sup>1</sup> P5007861      Cylinder Head, Aluminum, 48°, Small Block, A4 Midget Block, W9 (13°)
- <sup>1</sup> P5007855      Cylinder Head, Aluminum, 48°, Small Block, A4 Midget Block, W9 (15°)
- <sup>1</sup> P5007065AB    Cylinder Head, Aluminum, 48°, Small Blocks, W9



A.

---

## SMALL BLOCK

### CYLINDER HEADS, GASKETS, AND HARDWARE

#### A. Cylinder Heads, Magnum

Features higher airflow and performance over cast iron (stock) Magnum cylinder heads. Uses Magnum vertical-style intake manifold attachment and production exhaust flange pattern. No heat crossover.

- <sup>1</sup> P5153847 Cylinder Head, Aluminum, 5.2 / 5.9L Magnum, with valves and springs. 58 cc Combustion Chamber, 2.020"/1.600" Valves. Requires the use Of 1.6:1 Roller Rocker Arms (P5153852), Pushrods (P5153848), and Taller Than Stock Valve Covers (P5007617 or P5007618)
- <sup>1</sup> P5155469 Cylinder Head, Cast Iron, Bare, 1.920" IN, 1.624" EX, 62CC Chamber, 172CC IN Runner, 1992-2003 Magnum 5.2L / 5.9L

See chart for additional information.

#### B. Magnum Cylinder Head Conversion Components

Designed to allow the use of production Magnum heads on pre-1992 Small Block engines. Requires the use of Magnum cylinder heads, hydraulic pushrods, Jeep® tappets (P4529220AB), and eight Magnum engine rocker arms (P4876050) to oil rocker arms through tappet and pushrod. Not for use with Magnum Cylinder Head P5153847.

- <sup>1</sup> P5007477 Pushrod, Hydraulic, 7.625", Set of 16
- <sup>1</sup> P4876050 Rocker Arm Set, Single Cylinder, 5.2L/5.9L Magnum Engines and Magnum Crate Engines
- <sup>1</sup> P4529220AB Tappet, Hydraulic, Small Block/ 2.5L/4.0L Jeep Engines, Sold Individually



A.



B.

### SMALL BLOCK CYLINDER HEADS

Part Number	Description	Material	Chamber Size	Tappet Angle	Valve Angle	Valve Sizes	Valve Stem Size	Int. Port Volume	Int. Flow @.600"	Int. Port Shape	Exh. Port Shape	Valve Cover	Approx Weight
P5007445AB	W2	Cast iron	65 cc	48°	15°	2.02"/1.60"	3/8"	190 cc	265 cfm	Oval W2	"D" W2/5	Std 5 bolt	51
P5007708AB	W2	Cast iron	47 cc	48°	15°	2.02"/1.60"	3/8"	190 cc	265 cfm	Oval W2	"D" W2/5	Std 5 bolt	51
P5249769	W2	Cast iron	65 cc	59°	18°	2.02"/1.60"	3/8"	180 cc	260 cfm	Oval W2	"D" W2/5	Std 5 bolt	51
P5153599	W2	Cast iron	70 cc	59°	18°	2.02"/1.60"	3/8"	189 cc	260 cfm	Oval W2	"D" W2/5	Std 5 bolt	51
P5153600	W2	Cast iron	70 cc	59°	18°	2.02"/1.60"	3/8"	189 cc	260 cfm	Oval W2	"D" W2/5	Std 5 bolt	51
P5007509AB	P5 Hemi	Aluminum	N/A	45°/59°	10°/2°	N/A	5/16"	N/A	N/A	Rect.	Oval P5	P5 Hemi	36
P5007065AB	W9	Aluminum	62 cc	48°	15°	N/A	11/32"	200 cc	290 cfm	Rect. W8/9	"D" W7/9	Std 5 bolt	22
P5007855	W9 Partially Machined	Aluminum	52 cc	48°	15°	N/A	N/A	N/A	N/A	Rect. W8/9	"D" W7/9	Std 5 bolt	22
P5007861	W9 Partially Machined	Aluminum	52 cc	48°	13°	N/A	N/A	N/A	N/A	Rect. W8/9	"D" W7/9	Std 5 bolt	22
P5007904	W9 Raised Port, Partially Machined	Aluminum	N/A	48°	13°	N/A	N/A	N/A	N/A	N/A	N/A	Std 5 bolt	24
P5153847	Magnum - Assy	Aluminum	58 cc	59°	18°	2.02"/1.60"	11/32"	175 cc	260 cfm	Rect.	std	10 bolt	30
P5153849	Commando - Assy	Aluminum	63 cc	59°	18°	2.02"/1.60"	11/32"	177 cc	222 cfm	Rect. 360	std	Std 5 bolt	30
P4876310AB	Commando - Lg Port	Aluminum	50 cc	59°	18°	2.02"/1.60"	3/8"	188 cc	265 cfm	Rect. 360	std	Std 5 bolt	25
P5153850	Super Commando	Aluminum	63 cc	59°	18°	2.055"/1.60"	11/32"	N/A	265 cfm	Wide	std	Std 5 bolt	30





A.



B.



C.



C. P5153851



D.



E.



F.

## CYLINDER HEADS, GASKETS, AND HARDWARE

### A. Gaskets, Cylinder Head, Composite

Can be used for replacement or competition applications up to 12.5:1 compression ratio. Small Block four-bolt pattern. Sold as an engine set.

- <sup>1</sup> P4876048 Gasket, Cylinder Head, Composite Material, 5.9L Truck Magnum/Jeep Engines, Set
- <sup>1</sup> P4349557 Gasket, Cylinder Head, Composite Material, up to 4.06" Bore, 0.040" to 0.042" Compressed Thickness, Small Block
- <sup>1</sup> P4120094 Gasket, Cylinder Head, Composite Material, Up to 4.125" Bore, Up to 12.5:1 CR, Small Block

### B. Low Compression Ratio Composition Material Gasket

Not recommended for compression ratios over 10:5.1.

- P4120093 Gasket, Cylinder Head, Composition Material, Up to 4.060" Bore; 0.040" Thickness

### C. Head Bolt Sets

Includes all required head bolts.

- P5153851 Bolt Set, Cylinder Head with Washers, Use With Cylinder Heads P5153849 and P5153850
- P4120471 Bolt Set, Cylinder Head, 318/340/360 "LA" Engines up to 1992
- P4876759 Bolt Set, Cylinder Head, Magnum, Small Block/ 5.2L/5.9L Truck Magnum/Jeep Engines

### D. Head Stud Kits

Kits contain studs, nuts and washers for changeover of stock head bolts.

- P4876757 Stud Kit, Cylinder Head, Aluminum Block, W9 Heads
- P5007912 Stud Kit, Cylinder Head, Aluminum Block, W9 Raised Port Cylinder Head (A8 and A4 Engine Blocks with W9RP Cylinder Heads)

### E. Hardened Washer Sets

For use with head bolts and main caps. Sold in sets of 20.

- P4120459 Washer, Hardened, 1/2"
- P4120456 Washer, Hardened, 3/8"

### F. Exhaust Manifold Heat Shield - 340

- P2946105 Heat Shield, Exhaust Manifold, Driver's Side, 340

## SMALL BLOCK

### VALVE COVERS AND HARDWARE

#### A. Valve Covers, Aluminum, "As Cast"

Cast aluminum covers are more rigid than stamped steel, which helps prevent valve cover leaks. Sold "as cast" so you can set up the breathers required. There's no paint to remove if welding is done. Mopar Pentastar logo is cast into each cover. Set includes two valve covers and oil filler caps.

**P5007612AB** Valve Cover, Aluminum, "As Cast," Set

**P5249581AB** Gasket, Valve Cover, Five-Bolt Rubber with Steel Shim Reinforcement, 318/340/360/ "A" Engines up to 1992, Set

**P4452089** Gasket, Valve Cover, Race, Set

#### B. Valve Covers, Cast Aluminum, Polished

Polished to a chrome-like shine that's perfect for that show car engine look. Features Mopar Pentastar logo. Set includes two valve covers, two oil filler caps and baffle package.

**P5007613AB** Valve Cover, Cast Aluminum, Polished, Set

**P4452089** Gasket, Valve Cover, Race, Set

#### C. Valve Covers, Cast Aluminum, "Mopar Magnum"

Polished Cast Aluminum Valve Cover Sets are more rigid than stamped steel for better anti-leak properties. Features Magnum logo. Each set includes all grommets and a quarter-turn oil filler cap. Gaskets must be ordered separately.

**P5007618** Valve Cover, Cast Aluminum, Polished, 5.2L/5.9L Truck Magnum Engines, Set

**P5249660** Gasket, Valve Cover, 10-Bolt Mold Rubber Steel Shim, 5.2L/5.9L Truck Magnum Engines, Set of 2

#### D. Valve Covers, Cast Aluminum, Black Wrinkle

High-strength Cast Aluminum Valve Covers are more rigid than stamped steel, offering better anti-leak properties. Mopar Pentastar logo is cast into each cover. Set includes two valve covers, two oil filler caps and baffle package.

**P5007611AB** Valve Cover, Cast Aluminum, Black Wrinkle, Set

**P5007617** Valve Cover, Cast Aluminum, Black Wrinkle, 5.2L/5.9L Truck Magnum Engines, 1993 and Up, Set

**P5007619** Valve Cover, Cast Aluminum, Black Wrinkle, 1993-98 5.2L/5.9L Jeep Engines, Set

**P5249581AB** Gasket, Valve Cover, Five-Bolt Rubber with Steel Shim Reinforcement, 318/340/360/ "A" Engines up to 1992, Set

**P4452089** Gasket, Valve Cover, Race, Set

#### E. Valve Covers, Fabricated Aluminum

**P5155525** Valve Cover, Aluminum, Black, Wedge, Small Block



A.



B.



C.



D.



E.



A. P5007446



A. P4349632AB



B.



B.



C.



D.



E.



F.

## VALVE COVERS AND HARDWARE

## A. Valve Covers, Chrome

Dress up your engine compartment with these high-quality, chrome-plated stamped steel valve covers. Set includes two valve covers and grommets. Does not include gaskets, screws or baffling.

**P5007446** Valve Cover, Chrome, Mopar Pentastar Logo, Set

**P4349632AB** Valve Cover, Chrome, "Direct Connection" Logo, Small Block, Set

**P4452089** Gasket, Valve Cover, Race, Set

## B. Valve Cover Hardware- Chrome

For stamped steel valve covers only. Accessory set includes 12 chrome-plated screws and washers, one chrome-plated oil filter cap and two rubber grommets.

**P4120272** Valve Cover Accessory Set, Big Block or Small Block

**P5007419** Grommet and Plug Set, Valve Cover, Big Block or Small Block

**P5007458** Bolt Set, Valve Cover, Chrome, Big Block/Small Block, 12 Pieces

## C. Valve Covers, Wide

Five-bolt cover features reversed lip design that allows the cover to be wider on stock production gasket surface. Extra width allows for larger valve springs and longer rocker arms. Mopar Pentastar logo featured on each cover. Use with Stud Package P4876676.

**P4876124** Valve Cover, Wide, Stock Production Small Blocks and W2/W5/W7/W9 Flanges, Set

## Valve Cover Gaskets and Hardware- Wide (Not Shown)

**P4876676** Stud Kit, Wide "LA" and W8 Valve Covers, 10 Studs with Lock Nuts

**P5249581AB** Gasket, Valve Cover, Five-Bolt Rubber with Steel Shim Reinforcement, 318/340/360/ "A" Engines up to 1992, Set

## D. Baffle and Screw Package

For cast aluminum valve covers only.

**P5007052** Baffle and Screw Package, Big Block/ Small Block/ Truck Magnum/Jeep Engines

## E. Bolt Set- Valve Cover

Package includes 12 retaining bolts.

**P5007053** Retaining Screw, Valve Cover, Big Block/Small Block

## F. Bolt Set- Chrome

Fit 5.2L/5.9L Magnum valve cover packages P5007617 and P5007618. Designed for cast aluminum valve covers only. Set includes 20 bolts (ten per cover).

**P5007620** Bolt Set, Cast Aluminum Valve Cover, Small Block/ 5.2L/5.9L Truck Magnum/Jeep Engines

## SMALL BLOCK

### VALVE COVERS AND HARDWARE

#### A. Breather Caps, Chrome

For use with Mopar cast aluminum valve covers to fill extra valve cover holes. Push-in-style Breather Cap requires the use of Grommet Set P4529882.

- P4529881 Breather Cap, Push-In Style, Chrome
- P4529880 Breather Cap, Twist-On, Bottom Vented, Chrome
- P4120446 Breather Cap, with Tube
- P4529882 Grommet, Rubber, Use with Breather Cap P4529881

#### B. Grommet- Knockout

For use on the knockout hole of die cast valve covers. It is recommended that the hole be cleaned up to 0.950" to 0.980" for best seal.

- P5007921 Grommet, Knockout, Die-Cast Valve Cover, Set

#### C. Grommet- PCV & Breather

Grommets to service black, polished, or "as-cast" Mopar Cast Aluminum Valve Covers (except Hemi). Set includes one grommet for PCV and one that can be used for plug or opened for breather.

- P5249642 Grommet, Cast Aluminum Valve Cover, 5.2L/5.9L Truck Magnum/Jeep Engines, Set



A. P4120446



A. P4529880



B.



C.

## VALVES AND VALVE TRAIN HARDWARE

## A. Valves

These stainless Valves have swirl-polished underheads with no flat or ski jump areas. Each features a 3/8" stem diameter and one square groove.

- <sup>1</sup> P5249187 Valve, Exhaust, 1.60" Diameter, 4.97" Stem Length, 340/360 Small Block
- <sup>1</sup> P5249197 Valve, Exhaust, 1.60" Diameter, 5.29" Stem Length, W2/W5 Heads
- <sup>1</sup> P5249876 Valve, Exhaust, 1.625" Diameter, 4.93" Stem Length, 3.9L/5.2L/5.9L Magnum/Jeep Engines
- <sup>1</sup> P5249188 Valve, Exhaust, 1.65" Diameter, 4.97" Stem Length, 340/360 Small Block
- <sup>1</sup> P5249198 Valve, Exhaust, 1.65" Diameter, 5.29" Stem Length, W2/W5 Heads
- <sup>1</sup> P5249878 Valve, Intake, 2.02" Diameter, 4.91" Stem Length, 3.9L, 5.2L, 5.9L Truck Magnum/Jeep Engines
- <sup>1</sup> P4876397 Valve, Intake, 1.88" Diameter, 4.98" Stem Length, 340/360 Small Block
- <sup>1</sup> P5249875 Valve, Intake, 1.92" Diameter, 4.91" Stem, 3.9L/5.2L/5.9L Magnum/Jeep Engines
- <sup>1</sup> P5249877 Valve, Intake, 1.97" Diameter, 4.91" Stem, 3.9L/5.2L/5.9L Magnum/Jeep Engines
- <sup>1</sup> P5249185 Valve, Intake, 2.02" Diameter, 4.98" Stem Length, 340/360 Small Block
- <sup>1</sup> P5249195 Valve, Intake, 2.02" Diameter, 5.28" Stem Length, W2/W5 Heads
- <sup>1</sup> P5249186 Valve, Intake, 2.08" Diameter, 4.98" Stem Length, 340/360 Small Block
- <sup>1</sup> P5249196 Valve, Intake, 2.08" Diameter, 5.28" Stem Length, W2/W5 Heads
- <sup>1</sup> P4876580 Valve, X-Long, Intake, Race, 2.15" Diameter, 5.4065" Overall Length

A.



B.

## B. Valve Seals - Race

Sold in sets of 16.

- <sup>1</sup> P3690963AB Valve Seals, Race, 3/8" Stem, 0.530" Guide, Small Block

## C. Valve Seals

Made of high-temp Viton material, these Valve Seals feature a full or semi-umbrella shape for best dual-purpose use. Helps prevent oil seepage down valve guides. Not recommended for use with dual valve springs. Sold in sets of 16. Does not apply to 0.530" guide.

- <sup>1</sup> P4120492 Valve Seals, 3/8" Stem, Big Block/ Small Block
- <sup>1</sup> P5249661 Valve Seals, 5/16" Stem, 0.530" Guide, 426 Hemi and 5.2L/5.9L Magnum/Jeep Engines

C.



Questions? Call the Mopar Direct Connection Techline at 1-888-528-HEMI (4364)

<sup>1</sup> Not legal on pollution-controlled vehicles or vehicles registered for highway use.

## SMALL BLOCK

### VALVES AND VALVE TRAIN HARDWARE

#### A. Valve Keepers (Split Locks)

Made from hardened material. Single, double and triple groove styles available to meet your application requirements. Features a 3/8" stem diameter and is available in 7° and 10° angles. Can be used for restoration or performance applications. Set includes 16 pieces (two sets required for V8 engines).

- <sup>1</sup> P4120618 Valve Keepers, 7°, Single Groove
- <sup>1</sup> P4286612 Valve Keepers, 10°, Single Groove
- <sup>1</sup> P4120619 Valve Keepers, 7°, Double Groove

#### B. Valve Stem Lash Caps

These lash caps are 0.080" thick and fit between the end of the valve and the rocker arm tip. They are made of hardened steel for improved rocker tip durability. Larger area than stock valve tip to help spread the rocker loads. Sold in sets of 16.

- P4120626 Lash Caps, Valve Stem, 3/8" Stem, A/B/RB Engines
- P4120635 Lash Caps, Valve Stem, 5/16" Stem, 426 Hemi/ Big Block/ Small Block/ Truck Magnum/Jeep Engines

#### C. Valve Spring Retainers

Available in two levels of performance: Chrome Moly for heavy-duty applications and Titanium for top-level race performance. Sold individually.

- P4452032 Retainer, Valve Spring, Chrome Moly, 7 Degree, 8mm Stem Diameter, Single, 2.2L/2.5L SOHC and 5.2L/5.9L Magnum Engines
- P4452033 Retainer, Chrome Moly, 3/8", Single, Std Height, 7°
- P4007178 Retainer, Titanium, 3/8", Single, Std Height, 7°, 340/360 "LA"
- P4120785 Retainer, Titanium, 3/8", Dual, Std Height, 10°
- P4286775 Retainer, Titanium, 3/8", Triple, .060" Increase, 10°



A.



A.



B.



C.



C.

## VALVES AND VALVE TRAIN HARDWARE

## A. Valve Springs

High-pressure Valve Springs can be used on exhaust and intake valves for all high-performance applications. They feature a shorter, fully-compressed height and allow for increased valve lift. Springs maintain spring load at higher rpms. A must for high-performance cams. Sold individually. With a single spring, the damper is installed inside the main spring; with a dual spring, the damper is installed between the inner and outer springs. There are no dampers in the triple springs. The retainers listed are the basic recommendation. Check the actual retainer listing for other options: added installed height, materials and lock size.

<sup>1</sup> P5249464	Valve Spring, 3.9L/ 5.2L/ 5.9L Magnum Jeep/Truck
<sup>1</sup> P4876062	Valve Spring, 5.2L/5.9L Magnum Jeep/Truck
<sup>1</sup> P4876063	Valve Spring, Single, HP Jeep V-8
<sup>1</sup> P4286813	Valve Spring, Single, 0.380"/0.450" Lift
<sup>1</sup> P4286812	Valve Spring, Single, 0.430"/0.460" Lift
<sup>1</sup> P4120249	Valve Spring, Single, 0.430"/0.500" Lift
<sup>1</sup> P3690933	Valve Spring, Single, 0.440"/0.500" Lift
<sup>1</sup> P5249847	Valve Spring, Single, 0.480"/0.535" Lift
<sup>1</sup> P5249848	Valve Spring, Single, 0.480"/0.540" Lift
<sup>1</sup> P3614542	Valve Spring, Double, 0.500"/0.610" Lift
<sup>1</sup> P3412068	Valve Spring, Double, 0.500"/0.620" Lift
<sup>1</sup> P2806077	Valve Spring, Double, 0.500"/0.610" Lift
<sup>1</sup> P2946353	Valve Spring, Double, 0.520"/0.700" Lift
<sup>1</sup> P4876064	Valve Spring, Double, 0.590"/0.640" Lift

See chart for additional information.

## ROCKER ARMS, SHAFTS, SUPPORTS, AND HARDWARE

## B. Rocker Arms, Hydraulic

Features thicker cross-sectional material in pushrod socket area for added durability. Package set includes 16 heavy-duty hydraulic rocker arms (eight right, eight left), rocker shaft retainers and hold-down bolts. Rocker shafts not included.

<sup>1</sup> P4529742	Rocker Arm, Hydraulic, Production, 1.5 Ratio, Package
<sup>1</sup> P4529475	Rocker Arm, Hydraulic, Service, 1.5 Ratio, Left, Sold Individually
<sup>1</sup> P4529474	Rocker Arm, Hydraulic, Service, 1.5 Ratio, Right, Sold Individually

## C. Rocker Arm System, Pro Race

Complete rocker arm system made of high-strength aluminum, including shafts and bolts. Designed for high rpm, high load racing applications. Roller tip, needle bearing center pivot. Requires hollow pushrods and tappets for oiling. High-ratio rockers may require grinding on block and head for clearance. Not for street use.

<sup>1</sup> P5007470	Rocker Arm Set, 0.550" Offset, 1.6 Ratio, One Head Only, W9
-----------------------	---



A.



A.



B.



C.

Questions? Call the Mopar Direct Connection Techline at 1-888-528-HEMI (4364)

<sup>1</sup> Not legal on pollution-controlled vehicles or vehicles registered for highway use.

## SMALL BLOCK

### VALVES AND VALVE TRAIN HARDWARE

#### SMALL BLOCK VALVE SPRINGS

Part Number	Installed Height	Description	O.D.	Wire Diameter	Lift Range	Material	Retainer
P4529214	1.64"	Magnum, Cylindrical	1.31"	0.177"	0.350"/0.430"	Production	P4529216
P4529215	1.64"	Magnum, Conical	Prod.	—	0.350"/0.430"	Production	P4529217
P4286813	1.65"/1.70"	Single/Damper	1.39"	0.185"	0.390"/0.450"	Chrome Vanadium	P4452033, P4286573
P5249464	1.64"	Magnum, Dual/Damper	1.42"	0.187"	0.400"/0.525"	Chrome Silicon	P4452032
P4286812	1.83"/1.86"	Single/Damper	1.49"	0.208"	0.430"/0.460"	Chrome Vanadium	P4452033
P4120249	1.67"/1.70"	Single/Damper	1.50"	0.206"	0.430"/0.500"	Chrome Vanadium	P4452033
P3690933	1.83"/1.86"	Single/Damper	1.53"	0.224"	0.440"/0.510"	Chrome Vanadium	P4452033
P5249847	1.68"/1.70"	Single/Damper	1.50"	0.207"	0.480"/0.535"	Chrome Silicon	P4452033
P5249848	1.83"/1.87"	Single/Damper	1.55"	0.216"	0.480"/0.540"	Chrome Silicon	P4452769, 4289288
P4876062	1.64"	Magnum, Dual/Damper	1.42"	0.187"	0.480"/0.600"	Chrome Silicon	P4452032
P3614542	1.67"/1.70"	Dual/Damper	1.45"	0.185"	0.500"/0.610"	Chrome Silicon	P4452033, P4286573
P2806077	1.83"/1.86"	Dual/Damper	1.52"	0.215"	0.500"/0.610"	Chrome Vanadium	P4529288, P4120785
P3412068	1.68"/1.70"	Dual/Damper	1.46"	0.191"	0.520"/0.620"	Special	P4452033
P2946353	1.99"/2.0"	Dual/Damper	1.59"	0.224"	0.520"/0.700"	Special	P4120785
P4876064	1.86"/1.88"	Dual/Damper	1.60"	0.216"	0.590"/0.640"	Chrome Vanadium	P4529288, P4120785
P4007536	2.0"/2.02"	Triple	1.62"	0.225"	0.640"/0.745"	Chrome Silicon	P4286775
P5249849	2.0"/2.02"	Dual/Damper	1.55"	0.216"	0.650"/0.750"	Chrome Silicon	P4120785

1. All valve springs are sold individually.

2. On W7 heads and others with x-long valves, like the 5.40" length, the typical installed spring height is 2.00" so only the springs listed above for the 1.99" thru 2.02" installed heights can be used.

3. With a single spring, the damper is installed inside the main spring; with a dual spring, the damper is installed between the inner and outer spring. There is no damper in the triple springs.

4. Retainers listed are the basic recommendation. Check the actual retainer listing for other options-added installed height, materials, lock size.





A. P5153852



A. P5153995

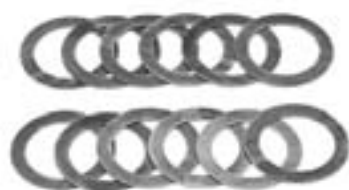

B.



C.



D.



E.



F.

## ROCKER ARMS, SHAFTS, SUPPORTS, AND HARDWARE

### A. Rocker Arms, Mechanical

Includes 16 aluminum roller rocker arms and all necessary hardware, rockers are adjustable.

- <sup>1</sup> P5153995 Rocker Arms, Aluminum, For Large Port Super Commando Head P5153850 With +0.350" Offset on the Intake Rockers, Engine Set

### B. Rocker Arm Spacer Set

- P3690896 Rocker Arm Spacer Set, 0.015" Thick, .878" I.D., 1.246" O.D., Set of 12
- P4529741 Rocker Arm Spacer Set, Hydraulic Production Style, A-Engine, Set of Eight

### C. Rocker Shafts

- <sup>1</sup> P4510636 Rocker Shaft, Hydraulic Valve Gear, On-Center, Sold Individually
- <sup>1</sup> P4120589 Rocker Shaft, Mechanical Valve Gear, Offset, W2/W5 Heads, Sold Individually
- <sup>1</sup> P3577086 Rocker Shaft, Mechanical Valve Gear, On-Center, 340 T/A, Sold Individually
- <sup>1</sup> P5249091 Rocker Shaft, Roller Valve Gear, Aluminum, On-Center, Set of Two

### D. Rocker Shaft Stands

Machined from T6061 billet aluminum, these high-strength Rocker Shaft Stands securely mount W2/W5 offset rocker shafts. Designed to upgrade cast aluminum rocker stands, these units will not flex, crack or crush. Each set contains ten stands (six narrow and four wide) and mounting bolts.

- <sup>1</sup> P5249049 Rocker Shaft Stand, Billet Aluminum, W2/W5 Heads

### E. Rocker Shaft Hold-Down

Billet Aluminum Rocker Shaft Hold-Down provides greater rocker shaft stiffness which helps rocker shaft maintain roundness when torque is applied. Roundness is important with mechanical rockers and high spring loads. Anodized blue.

- <sup>1</sup> P5249712 Rocker Shaft Hold-Down, Standard Small Block Heads
- <sup>1</sup> P5249713 Rocker Shaft Hold-Down, W2 Heads

### F. Rocker Shaft Retainers and Bolts

Package contains previously hard-to-find hold down retainers and bolts necessary to secure both rocker shafts. Manufactured to Mopar original equipment specifications to assure high quality. For use on all cylinder heads with cast-in rocker stands.

- <sup>1</sup> P4529740 Rocker Shaft Retainers and Bolts

## SMALL BLOCK

### ROCKER ARMS, SHAFTS, SUPPORTS, AND HARDWARE

#### A. Rocker Arms, Roller

These complete Roller Rocker Arm Sets for Magnum engines include 16 roller tip rocker arms, pivots, guides, and pushrods. Rockers are die-cast aluminum and are individually adjustable. Can be used as heavy-duty replacement with standard or high-performance hydraulic camshafts. May interfere with production Magnum engine valve covers. High-ratio rockers will increase valve lift - use matching valve spring, and check piston-to-valve clearance. Not for use with Cylinder Head P5153847.

<sup>1</sup> P5007404 Rocker Arm, Roller, 1.7:1 Ratio, 5.2L/5.9L Dodge Truck Magnum/Jeep Engines. Fits Production and R/T Heads.

#### B. Rocker Arm Stud Kit

Required with aluminum Magnum cylinder heads and aluminum roller rocker arms. Does not fit P5153847 head.

P5007645 Stud Kit, Rocker, Roller, 3/8" Coarse Thread, 5.2L/5.9L Truck Magnum/Jeep Engines



### INTAKE MANIFOLDS, HARDWARE, AND GASKETS

#### C. Single Plane Intake Manifolds

<sup>1</sup> P5155314 Intake Manifold, Aluminum, Single Plane, Victor Style, Big Port and Standard Holley Four-barrel Carburetor, "LA" Engine with Super Commando Heads

<sup>1</sup> P4876334 Intake Manifold, Aluminum, Single Plane, Four-barrel Carburetor, 1967-91, Standard Heads

<sup>1</sup> P5007380AB Intake Manifold, Aluminum, Single Plane, Four-barrel Carburetor, 5.2L/5.9L Truck Magnum/Jeep Engines, Magnum Crate Engines

<sup>1</sup> P4876829AB Intake Manifold, Aluminum, Single Plane, Four-barrel Carburetor, Large Oval Port, 9.200" Deck, W2 Cylinder Heads

<sup>1</sup> P4529408 Intake Manifold, Aluminum, Single Plane, Four-barrel Carburetor, Oval Port, Water Heat 9.600" Deck, W2 Cylinder Heads

<sup>1</sup> P4532598 Intake Manifold, Aluminum, Single Plane, Four-barrel Carburetor, Rectangle Port, 9.000" Deck, W7/W8/W9 Cylinder Heads

<sup>1</sup> P4876162 Intake Manifold, Aluminum, Single Plane, Four-barrel Carburetor, Rectangle Port, 9.600" Deck, W7/W8/W9 Cylinder Heads

A.



B.



C.

## INTAKE MANIFOLDS, HARDWARE, AND GASKETS

### A. Dual Plane Intake Manifolds

- <sup>1</sup> P4876335AB Intake Manifold, Aluminum, Dual Plane, Four-barrel Carburetor, 1967-91, Standard Heads
- <sup>1</sup> P5007381AB Intake Manifold, Aluminum, Dual Plane, Four-barrel Carburetor, 5.2L/5.9L Truck Magnum/Jeep Engines
- <sup>1</sup> P5249572AB Intake Manifold, Aluminum, Dual Plane, Four-barrel Carburetor, 9.200" Deck, W2 Cylinder Heads
- <sup>1</sup> P5249572 Intake Manifold, Aluminum, Dual Plane, Four-barrel Carburetor, 9.560" Deck, W2 Cylinder Heads
- <sup>1</sup> P5155426 Intake Manifold, Aluminum, Dual Plane, Four-barrel Carburetor, 9.600" Deck, W2 Cylinder Heads
- <sup>1</sup> P5249193 Intake Manifold, Cast Iron, "A" Engine W2, 2BBL

### B. Dual Plane Intakes - Six Pack

- <sup>1</sup> P4529054 Intake Manifold, Aluminum, Dual Plane, Six Pack, Rectangle Port (1967-91 Small Block)

### C. Intake Manifold Gasket Sets

Custom-fit for use with Small Block cylinder heads. Complete kit to service one engine including gaskets, end seals, O-rings, and distributor seal (where applicable).

- P4876049 Gasket, Intake Manifold, 5.9L Magnum Jeep/Truck
- P4452101 Gasket, Intake Manifold, Small Block, 0.060" Thick
- P4120210AB Gasket, Intake Manifold, W2 Heads, 0.030" Thick
- P4120211AB Gasket, Intake Manifold, W2 Heads, 0.045" Thick
- P4007571AB Gasket, Intake Manifold, W2 Heads, 0.060" Thick
- P4876446 Gasket, Intake Manifold, W2 Heads, 0.090" Thick
- P4876447 Gasket, Intake Manifold, W2 Heads, 0.115" Thick
- P5249466 Gasket, Intake Manifold, W5 Heads, 0.060" Thick
- P5249480 Gasket, Intake Manifold, W7 Heads, 0.030" Thick
- P5007153AB Gasket, Intake Manifold, W9 Heads, 0.030" Thick
- P5007154AB Gasket, Intake Manifold, W9 Heads, 0.045" Thick
- P5007155AB Gasket, Intake Manifold, W9 Heads, 0.060" Thick
- P4007570AB Gasket, Intake Manifold, Standard "LA", 0.055" Thick
- P4286569 Gasket, Intake Manifold, Standard "LA", 0.055" Thick, with Heat Block-off Plate

### D. Intake Manifold Attaching Bolts

A complete package of bolts required to attach the intake manifold to the cylinder heads. Engine set.

- P4876771 Bolt Package, Intake Manifold, 3/8" x 1-5/8", 1967-91 Small Block
- P4876772 Bolt Package, Intake Manifold, 5/16" x 2-3/4", 1992-98 5.2L/5.9L Magnum Jeep/Truck



A.



B.



C. P4120210



C. P4876049



D.

Questions? Call the Mopar Direct Connection Techline at 1-888-528-HEMI (4364)

<sup>1</sup> Not legal on pollution-controlled vehicles or vehicles registered for highway use.

## SMALL BLOCK

### INTAKE MANIFOLDS, HARDWARE, AND GASKETS

#### A. Bypass Hose

Designed to go from the intake manifold to the water pump. Made of heavy-duty silicone rubber. Includes two clamps.

**P4876373** Bypass Hose, 1970-91 Small Block

**P4876374** Bypass Fitting, Intake Manifold, Adapts Bypass Hose to Manifold, 1970-91 Small Block

#### B. Choke Seal

For dual plane production and aluminum intake manifolds. Package includes choke cup, gasket and two screws.

**P5249639** Choke Seal, Big Block/ Small Block

#### C. 360 Magnum Crate Engine Fuel Injection Kit

Mopar now has fuel injection kits available for 380/390/395 horsepower-rated 360 cid Magnum crate engines with automatic or manual transmissions. Installing one of these kits on your powerplant will improve fuel distribution and cylinder filling, resulting in impressive mid-range torque response and horsepower gains over standard carburetion. Mopar 360 Magnum crate engine fuel injection kits come complete and provide excellent throttle response, driveability and improved fuel economy. Developed in collaboration with Mopar Action Magazine.

##### Features:

- Factory-engineered "Plug 'n Play" wiring harness for easy installation
- JTEC engine controller with unique calibration
- Intake manifold assembly with 1,000 cfm four-barrel throttle body, fuel rail and 33 lbs./hr. fuel injectors
- External electric fuel pump, filter and fuel regulator
- Distributor, ignition wires and coil
- Complete set of new OEM sensors
- Engineered for Mopar 360 Crate Engines: P5249499, P5155074, P4510851, P5153475, P5007646

<sup>1</sup> **P5153590** Fuel Injection Kit, Automatic Transmission, 380/390/395 hp 360 Magnum Crate Engine

Note: Requires use of P4876706 Flex Plate or Magnum Flywheel 53020585 or Dual Trigger Distributor.

**IMPORTANT NOTICE:** This device is not legal for use on pollution-controlled vehicles certified for use on streets or highways. Once this device is installed, use of the vehicle on a street or highway is a violation of the Clean Air Act, potentially subjecting the operator and the installer to civil penalties of up to \$32,500 per vehicle depending on the circumstances.



A.



B.



C.



A. P5007790



A. P5007398AB



B.



C. P5153702



D.



E.

## INTAKE MANIFOLDS, HARDWARE, AND GASKETS

### A. Aluminum Single Plane Intakes - MPI

Can be used as a direct replacement for production engines. Allows use of air conditioning and all factory accessories. Designed to use production throttle body, injectors, fuel rail and other hardware from your stock intake. Available in EGR and non-EGR. Replacement for stock.

- <sup>1</sup> **P5007790** Intake Manifold, Aluminum, Single Plane, Two- or Four-barrel EFI, Right Linkage, 5.2L/5.9L Magnum Jeep/Truck, Requires Modifications
- <sup>1</sup> **P5007398AB** Intake Manifold, Aluminum, Single Plane, Two-barrel EFI with EGR, 1992-97 5.2L/5.9L Magnum Jeep/Truck, Requires Installation Kit P5007638
- <sup>1</sup> **P5007852** Intake Manifold, Aluminum, Single Plane, Two-barrel EFI without EGR, 1998-2003 5.2L/5.9L Magnum Jeep/Truck, Requires Installation Kit P5007638
- <sup>1</sup> **P5007638** Installation Kit, Intake Manifold, Two-barrel Intake Only, 5.2L/5.9L Truck Magnum/Jeep Engines

### B. Throttle Body Adapter

You can save time and money by using this Mopar Throttle Body Adapter. Although it will require minor fabrication, this adapter will allow you to use a stock Magnum engine throttle body on a four-barrel carburetor intake.

- <sup>1</sup> **P5007865** Throttle Body Adapter, 5.2L/5.9L Dodge Truck Magnum/Jeep Engines

### C. Throttle Body- 360 Magnum

- <sup>1</sup> **P5153702** Throttle Body, Service part for 360 Fuel Injection Kits

Note: Pinout is different from Delphi IAC and Mopar IAC

## OILING COMPONENTS

### D. Oil Pans

Includes a factory-engineered and approved Oil Pan and pickup, drain plug and washer. Center sump- style is used on passenger car applications, while the rear sump-style is used for pickups. Mopar Windage Trays may be used if desired.

- P5249062** Oil Pan, Five-quart, Rear Sump, 273/318/340 Small Block
- P5249060** Oil Pan, Five-quart, Rear Sump, 360 Small Block and 5.9L Magnum

### E. Oil Pan Bolt Set

- P4120613** Bolt Set, Oil Pan, 426 Hemi, Big Block/ Small Block, Set of 20 Bolts

## SMALL BLOCK

### OILING COMPONENTS

#### A. Oil Pan Gaskets

- P4452097 Gasket, Oil Pan, 1970-90 318/340 Small Block
- P4007573 Gasket, Oil Pan, 360 Small Block
- P5249932 Gasket, Oil Pan, 5.9L Dodge Truck Magnum/Jeep Engines
- P4452093 Gasket, Oil Pan, Race, 360 Small Block
- P4007572 Gasket, Oil Pan, Reusable, 318/340 Small Block

#### B. Oil Pickup and Screen Assemblies

Factory original reissued Oil Pickup and Screen Assembly. Standard pickups are 3/8".

- <sup>1</sup> P4529563 Oil Pickup and Screen Assembly, Center Sump Pans P5249059 and P5249061 (Small Block)

#### C. Oil Pressure Relief Spring

Increases engine oil pressure over stock spring for high-performance applications. Delivers up to 70 lbs. of oil pressure. Includes a cap and instructions.

- <sup>1</sup> P3690944 Oil Pressure Relief Spring, Small Block/ 2.2L/2.5L/ 3.9L V6, Set

#### D. Windage Tray

Designed to provide improved engine lubrication by reducing the interior windage at higher engine speeds. Includes Windage Tray and mounting hardware (mounting hardware also available separately).

- <sup>1</sup> P4529790 Windage Tray Package, 318/340/360 Small Block
- <sup>1</sup> P3690939 Hardware Kit, Windage Tray, 318/340/360 Small Block

#### E. Oil Pump Assembly

This high-output oil pump assembly provides a 25% increase in oil volume. Ideal replacement for stock pump in high-performance applications.

- <sup>1</sup> P4286589 Oil Pump Assembly, Small Block, 3.9L V6

#### F. Distributor Drive Gear Assemblies

Features hardened tip shaft with full radius blend from hex to round and pinned gear.

- <sup>1</sup> P3690874 Distributor Drive Gear, Billet Roller Cam, Aluminum-Bronze Gear
- <sup>1</sup> P3690715 Distributor Drive Gear, HD

#### G. Tube and Peen Tool Package

Blocks off oil to right-side tappet bores. Required for race engines with high-lift roller cams.

- <sup>1</sup> P4120603 Tube and Peen Tool Package (Small Block)



A. P4007573



A.



B.



C.



D.



E.



F.



G. P4120603



A.



B.



C.



D.



E.



F. P4529805



F.



G.

## OILING COMPONENTS

### A. Right Angle Oil Filter Adapter Kit

Allows 90° rotation of the oil filter. Made of aluminum and provides necessary clearance for headers, engine swaps, etc. Filter not included.

- P5249624AB Oil Filter Adapter, Right Angle
- P5249320 Gasket, for Oil Filter Adapter P5249624AB
- P5007515 Mounting Screw, for Oil Filter Adapter, P5249624AB

### B. Oil Pump Priming Shaft

Don't fire up that engine without pre-lubing (priming) it thoroughly with oil. Special hardened steel shaft fits on any 3/8" or larger drill. Insert shaft into hole where distributor fits. Pressurizes oil galleries to ensure against dry starts and subsequent engine damage. Fits all V8 engines.

- P4286800 Shaft, Oil Pump Priming

### C. Dipstick and Tube, Chrome

- P4349628 Dipstick and Tube, Chrome, Center Sump Pan, Small Block Passenger Cars

### D. Oil Filter- Performance

Engineered to meet the demands of heavy-duty and high-performance applications. Black with Mopar Pentastar logo.

- P4452890 Oil Filter, High-Performance, Black Finish, 6/8 Cylinder Engines

### E. Oil Filter - Race

High-performance, heavy-duty Race Oil Filter has a thicker canister with high burst strength. Black with Mopar Pentastar logo.

- P4529190 Oil Filter, Race, Black Finish, 426 Hemi, Big Block, Small Block

### F. Oil Filter- Restoration

Mopar has reissued these service replacement Restoration Oil Filters used in the 1960s and 1970s. The white filter was used from the 1960's throughout the 1970's. The high-performance white filter (P4529805) was recommended for use in competition from 1965-74. These filters may not fit some V8 applications (those after 1972 requiring short filters).

- P4529806 Oil Filter, Restoration, Black with Yellow Mopar logo, 1962-66 V8
- P4529805 Oil Filter, Restoration, High-Performance, White with Red Stripe

## COOLING SYSTEMS

### G. Water Pumps

Mopar Aluminum Water Pumps feature basic high flow designs. The six-blade pump is recommended for use with cast iron cylinder heads and for drag racing applications. The eight-blade pump is recommended for use with aluminum cylinder heads and for circle track applications. Passenger side lower hose inlet (1970 and up Small Block).

- <sup>1</sup> P5249558 Water Pump, Aluminum, 6-Blade
- <sup>1</sup> P5249559 Water Pump, Aluminum, 8-Blade

## SMALL BLOCK

### COOLING SYSTEMS

#### A. Water Pump, Race

Mopar Race Aluminum Water Pumps provide extra high flow. Must be used with Sand Cast Race Timing Cover P4876632 (NASCAR Only) and Motor Plate.

<sup>1</sup> P4876548 Water Pump, Aluminum, Race, use with Timing Chain Cover P4876632



A. P4876548

#### B. Bolt Set, Water Pump, Chrome

Engine chrome dress-up projects just aren't complete without chrome bolts.

P4529256 Bolt Set, Chrome, Water Pump, 1969-92 "A" Engine



B.

#### C. Thermostat Housing, Chrome

This high-quality housing is made of heavy-duty material. Includes gasket and two chrome bolts.

P4452025 Water Neck, Chrome, 1979-93, V8 and V6

P4286759 Water Neck, Chrome, Up To 1978, V8

#### D. 90 Degree Thermostat Housing

Cast aluminum housing provides greater flexibility in routing cooling system hoses and improves the appearance of the engine compartment. Features three-direction capability -- ideal for compact engine compartments.

P5249191 Thermostat Housing, 90 Degrees

#### E. Thermostat

Heavy-duty Mopar Thermostat can handle increased heat management duties in high-performance engines. Replacement gasket included.

P4876307 Thermostat, 180 Degree, 426 Hemi/Big Block/Small Block/Slant Six Engines, Up to 1978

P4876308 Thermostat, 195 Degree, 1979 and Up



C.



D.

#### F. Viscous Fan Package

Most late 1960s and early 1970s factory-built muscle cars were equipped with viscous fans for cooling purposes. This package provides thermostatically controlled cooling and includes a lightweight balanced fan. Offers up to 15 horsepower gain on typical high-performance V8s. 15" fan blade 3 1/4" deep.

P4120758 Viscous Fan Package, 18" fan. 3.25 Pitch



E.



F.



## MOPAR® RESTORATION: Winning

If it ain't original, it ain't worth having. So sayeth the wise man. Which is why true enthusiasts skip the pretenders and head straight to Mopar® Restoration Parts. They're designed from the same blueprints as the originals, often cast from the same molds, for a quality that puts the aftermarket to shame. Authentic Performance isn't just an advertising slogan; it's a promise.





# FUEL SYSTEMS .05

P  
R  
I  
N  
T  
I  
N  
G  
S



27-11-1994 11:25

## FUEL SYSTEMS

### CARBURETORS AND HARDWARE

#### A. Holley Universal Carburetor

Features universal calibration, a manual choke, center-hung bowls and vacuum secondary.

<sup>1</sup> P4349228 Carburetor, Holley Universal, R3310, 750 cfm (Big Block and Small Block)

#### B. Holley Cross Ram Carburetors

Holley Carburetors were the "go fast" choice for the legendary Super Stock 426 Hemi® engine. Mopar brings back these original equipment Holley carburetors for 1964, 1965 and 1968 race Hemis. These are exact reissues of the original carburetors. Airflow is 770 cfm.

<sup>1</sup> P4452779 Carburetor, Cross Ram, Left, 1964–65, 1968 Race Hemi

<sup>1</sup> P4452778 Carburetor, Cross Ram, Right, 1964–65, 1968 Race Hemi

#### C. Holley Service Gasket Set

This handy carburetor service gasket set includes everything required to service and performance-tune your Holley. Package includes only the necessary parts for proper servicing of the following: primary bowl, primary metering block, secondary bowl, secondary metering block/plate gaskets, required bowl screw O-rings and fuel transfer tube O-rings.

P4349304 Gasket Set, Carburetor, Holley Service, 2-bbl, R4412 and 7448, 340/440/Hemi Six Pack, Holley Cross Ram

#### D. Cross Ram Carburetor Air Horns

For use with Holley Cross Ram Carburetors. Perfect for Super Stock competition or restoration. Sold as a pair (front and rear).

<sup>1</sup> P5007809 Air Horns, 1964-65 426 Hemi, 1968 Super Stock 426 Hemi

#### E. Cross Ram Linkage

Use with Hemi® Cross Ram Intake Manifold (P5007534) and Holley Carburetors (P4452778 and P4452779). Refer to the Hemi sections of this catalog for more information.

<sup>1</sup> P4510635 Linkage, Cross Ram, Hemi

#### F. Throttle Cable Mounting Bracket

Designed to hold the stock throttle cable to Mopar Performance Magnum Intake Manifold. Will hold throttle cable in proper relationship to carburetor. Includes hardware.

P4876850 Bracket, Throttle Cable, Magnum 300/ 380/ 395/ 435 Crate Engines with Carburetor

P4876314 Bracket, Throttle Cable, Used with Magnum V8 W/CARB, Single Plane 4BBL

#### G. Throttle Cable Mounting Bracket, Tall

Used to attach the throttle cable to Mopar M1® Single Plane Intake Manifolds or when using a 1-inch carb spacer.

P4510318 Bracket, Throttle Cable, Tall, Big Block



A.



B.



C.



D.



E.



F.



G.

**CARBURETORS AND HARDWARE**

**A. Tall Return Spring Bracket**

Use on Mopar M1® Single Plane Intake Manifold applications or when using a 1-inch carb spacer.

**P4510646** Bracket, Throttle Return Spring, Tall, Big Block

**B. Accelerator Return Spring Bracket**

Designed for Magnum Crate Engines with four-barrel carburetor intake manifolds. Developed to hold accelerator pedal return spring in proper relationship to carburetor.

**P4876313** Bracket, Accelerator Return Spring, 4-bbl, 300/380/395/435/Magnum Crate Engines

**C. Carburetor Kickdown Bracket**

Use with Automatic Transmission Kickdown Cable (P4510646). Refer to Automatic Transmission section of this catalog for more information.

**P4510319** Bracket, Carburetor Kickdown, Big Block

**D. Max Wedge Intake Linkage Package**

For use with Max Wedge Intake Manifold (P5007330) with Carter AFB Carburetors or Edelbrock Performer Series Carburetors.

**P5153567** Linkage Kit, Max Wedge Intake Manifolds

**E. Thin Carburetor Adapter**

Designed with air/fuel flow technologies in mind versus ease of machining. Tested and used by top engine builders, these adapters are only 1/16-inch thick and allow the use of square bore carburetors on spread bore manifolds.

**P5007869** Carburetor Adapter, Thin, Big Block/ Small Block

**F. Throttle Cable, Street Hemi**

A performance Throttle Cable for Street Hemi applications. Includes the retaining clip and a plug to finish the installation.

**P4529112** Throttle Cable, 19 3/4" Long, 1968-70 Hemi B-Body

**FUEL PUMPS AND HARDWARE**

**G. Fuel Pumps, Mechanical**

Provides higher delivery rate than stock at 80 gph @ 8.7 psi. unless otherwise stated.

<sup>1</sup> **P4007039AB** Fuel Pump, Mechanical, 426 Hemi/ Big Block

<sup>1</sup> **P4529368** Fuel Pump, Mechanical, 65 GPH at 6.5 to 8 PSI Running at 800 RPM, A-Engine

<sup>1</sup> **P4007040** Fuel Pump, Mechanical, Small Block

**H. Fuel Pump Eccentric, Moly-Coated**

The moly coating on this Fuel Pump Eccentric significantly reduces friction and wear.

<sup>1</sup> **P4120484** Fuel Pump Eccentric, Moly-Coated, Small Block



A.



B.



C.



D.



E.



F.



G.



H.

Questions? Call the Mopar Direct Connection Techline at 1-888-528-HEMI (4364)

<sup>1</sup> Not legal on pollution-controlled vehicles or vehicles registered for highway use.

## FUEL SYSTEMS

### FUEL PUMPS AND HARDWARE

#### A. Fuel Pump Block-Off Plate, Chrome

Covers the hole created when removing the mechanical fuel pump for replacement with electric pump. Gasket included.

<sup>1</sup> P5007546 Block-Off Plate, Fuel Pump, Chrome

### VAPOR SEPARATOR

#### B. Vapor Separator

77R06295 Vapor Separator, 1968-71 440/426 HEMI

### SIX PACK INDUCTION SYSTEMS

Some of the fastest vehicles of the muscle car era were powered by Six Pack powerplants. Mopar now offers the components to restore or build your own Six Pack car.

#### C. Six Pack Holley Carburetors

These carburetors are exact reissues of the original equipment Six Pack. Order one center and two outboard carburetors to match your engine. Six Pack "A" engines use intake manifold P4529054. Six Pack "RB" engines use intake manifold P4529056. Refer to the Big Block and Small Block sections of this catalog for more information.

- <sup>1</sup> P4349237 Carburetor, Holley, Center 1971 "RB" Six Pack, Manual Transmission
- <sup>1</sup> P4349235 Carburetor, Holley, Center, 1969-70 "B"/"RB" Six Pack
- <sup>1</sup> P4349241 Carburetor, Holley, Center, Small Block Six Pack, Automatic Transmission
- <sup>1</sup> P4349239 Carburetor, Holley, Outboard, "B" Six Pack and Small Block Six Pack
- <sup>1</sup> P4349236 Carburetor, Holley, Outboard, 1969-70 "RB" Six Pack
- <sup>1</sup> P4349238 Carburetor, Holley, Outboard, 1971 "RB" Six Pack

#### D. Six Pack Secondary Diaphragm Set

For use with Holley Six Pack two-barrel outboard carburetors. Sold individually.

P4349321 Secondary Diaphragm Set, Six Pack

#### E. Six Pack Gasket Set

Set features O.E. gaskets made exactly the way they were in the early 1970s and includes three premium quality air cleaner and carburetor-to-manifold gaskets. Fits all six-barrel applications.

P4529060 Gasket, Six Pack, Set

#### F. Six Pack Choke Thermostat Assembly

Reproduction O.E. Choke Thermostat Assembly. Fits all production six-barrel applications.

P4529185 Choke Thermostat Assembly, Six Pack



A.



B. 77R06295



C.



D.



E.



F.

SIX PACK INDUCTION SYSTEMS

**A. Six Pack Fuel Line Kit**

This exact reproduction of the O.E. Six Pack fuel lines includes two fuel tees and the four fuel tubes.

**P4529264** Fuel Line, Six Pack

**B. Six Pack Installation Kits**

Mopar carries a full line of six-barrel components for both Small Block and Big Block applications, right down to these installation kits. Kits include throttle cables, fuel lines, coil brackets, linkage kit, choke, nuts, springs and washers. Buy the six-barrel carburetors, manifold and air cleaner, then install them with this complete O.E. reproduction kit.

**P4529059** Installation Kit, Six Pack, Big Block

**P4529058** Installation Kit, Six Pack, Small Block

**C. Six Pack Linkage Kit**

Perfect for repair or restoration projects. Kit includes front carb rod, rear carb rod, front and rear clips, adjusting pivot, throttle cable, bolt, nut, clip and washer assembly.

**P4529061** Linkage Kit, Six Pack

**D. Throttle Cable, Six Pack**

This performance cable includes the retaining clip and a plug to finish the installation.

**P4529111** Throttle Cable, 1970-71 Six Pack E-Body and 1971 Six Pack B-Body

**E. Six Pack Air Cleaner Lids**

Top off your Six Pack with a Mopar air cleaner lid. Designed and produced to factory specifications for the perfect finish.

**P4529748** Air Cleaner Lid, Chrome, Six Pack

**P2946393** Air Cleaner Lid, Orange, Six Pack

**F. Six Pack Air Cleaner Assembly Kits**

This low-profile, high-flow air cleaner tops off the Six Pack system. Kits include metal base, orange lid, studs, nuts, gaskets and air filter. They were designed specifically for 1970-71 B- and E-body vehicles, but they can be used for other vehicle applications as well.

**P5007737AB** Air Cleaner Kit, Cold Air, 1970 440 Six Pack with Air Grabber or Ramcharger Hood Scoop

**P4529057AB** Air Cleaner Kit, Non-Cold Air, Six Pack

**G. Six Pack Restoration Air Filter Element**

**P4529965AB** Air Filter, Resto Six Pack and Hemi



A.



B.



C.



D.



E.



F.



G.

## FUEL SYSTEMS

## AIR SYSTEMS

### A. Air Cleaner Lids

**77R06094** Air Cleaner Lid, Used On Air Grabber Hoods, 1970 Road Runner/GTX

### B. Cast Air Cleaner Systems

Features a black cast aluminum lid with the Mopar Pentastar logo to match the style of the cast aluminum Mopar valve covers. Includes 12-3/4-inch x 2-3/4-inch element.

**P5249807** Air Cleaner, Cast, Hemi/ Big Block/ Small Block/ 5.2L/5.9L Magnum/Jeep Engines

### C. Replacement Air Cleaners

These are original-style (unsilenced) Replacement Air Cleaners, as found on 1968-69 340, 383 and 440 high-performance engines. Air cleaners are offered in chrome-plated. The chrome air cleaner is available with or without a breather tube. All air cleaner packages come with a base plate, filter element, base-to-carb gasket, air cleaner stud and chrome-plated wing nut. These air cleaners provide better airflow to help produce more horsepower than most aftermarket air cleaners. To top off your air cleaner, add one of Mopar's original style engine identification plates.

**77R06313** Air Cleaner, Chrome, Dual 4bbl (with small carb throats), 426 HEMI "Chrome Dome"

**P4529025** Air Cleaner, Chrome, with Breather Tube, 383/440 Big Block/ 340 Small Block

**P4529002** Air Cleaner, Chrome, without Breather Tube, 383/440 Big Block/340 Small Block



A.



B. P5249807



C.





A.



B.



C.

## AIR SYSTEMS

### A. Engine ID Plates

Most cars equipped with 340, 383 or 440 engines rolled out of the assembly plant with an Engine Identification Plate on top of the air cleaner. Mopar has 21 different original style plates to cover all engines that were available during the muscle car era. The proper selection of engine ID plates is as follows: 1967-68 Red; 1969-71 Orange. Plates to cover engines that were not available in the 1960s and 1970s are also available (318 four-barrel, 360 four-barrel, 440 four-barrel, Hemi four-barrel and 360 Magnum).

- P4876415 Engine ID Plate, Orange, 318 4-bbl
- P4529083 Engine ID Plate, Orange, 340 4-bbl
- P4876416 Engine ID Plate, Orange, 360 4-bbl
- P4876414 Engine ID Plate, Orange, 360 Magnum
- P4529085 Engine ID Plate, Orange, 383 Magnum
- P4529073 Engine ID Plate, Orange, 383 Road Runner
- P4529081 Engine ID Plate, Orange, 383 Super Commando
- P4876417 Engine ID Plate, Orange, 440 4-bbl
- P4529077 Engine ID Plate, Orange, 440 Chrysler TNT
- P4529071 Engine ID Plate, Orange, 440 Magnum
- P4529079 Engine ID Plate, Orange, 440 Super Commando
- P4876448 Engine ID Plate, Orange, Hemi 4-bbl
- P4529084 Engine ID Plate, Red, 340 4-bbl
- P4529075 Engine ID Plate, Red, 383 4-bbl
- P4529076 Engine ID Plate, Red, 383 Commando
- P4529086 Engine ID Plate, Red, 383 Magnum
- P4529074 Engine ID Plate, Red, 383 Road Runner
- P4529082 Engine ID Plate, Red, 383 Super Commando
- P4529078 Engine ID Plate, Red, 440 Chrysler TNT
- P4529072 Engine ID Plate, Red, 440 Magnum
- P4529080 Engine ID Plate, Red, 440 Super Commando

### B. Air Cleaner Wing Nut

Judges notice everything, right down to the wing nut on your air cleaner. This exact factory reproduction guarantees you won't lose valuable judging points the next time you're at the Mopar Nationals. Sold individually.

- 77R06283 Wing Nut, Air Cleaner, V-8

### C. Breather Hose

- 77R06312 Breather Hose, Air Cleaner, 1966-71 V8 Applications

## FUEL SYSTEMS

### FUEL INJECTION

#### A. 360 Magnum Crate Engine Fuel Injection Kit

Mopar now has fuel injection kits available for 380/390/395 horsepower-rated 360 cid Magnum crate engines with automatic or manual transmissions. Installing one of these kits on your powerplant will improve fuel distribution and cylinder filling, resulting in impressive mid-range torque response and horsepower gains over standard carburetion. Mopar 360 Magnum crate engine fuel injection kits come complete, and provide excellent throttle response, drivability and improved fuel economy. Developed in collaboration with Mopar Action Magazine.

##### Features:

- Factory-engineered "Plug 'n Play" wiring harness for easy installation
- JTEC engine controller with unique calibration
- Intake manifold assembly with 1,000 cfm four-barrel throttle body, fuel rail, and 33 lbs./hr. fuel injectors
- External electric fuel pump, filter and fuel regulator
- Distributor, ignition wires and coil
- Complete set of new OEM sensors
- Engineered for Mopar 360 Crate Engines: P5249499, P5155074, P4510851, P5153475, P5007646

<sup>1</sup> P5153590 Fuel Injection Kit, Automatic Transmission, 380/390/395 hp 360 Magnum Crate Engine

Note: Requires Use of P4876706 Flex Plate or 143 Tooth Magnum Flywheel 53020585 or Dual Trigger Distributor.

#### B. Fuel Pump, Electric, 360 Magnum

<sup>1</sup> P5153688 Fuel Pump, Electric, Service part for 360 Fuel Injection Kits



A.



B.

# IGNITION AND ELECTRONICS .06



P  
R  
I  
O  
R  
I  
T  
Y  
M  
A  
N

## IGNITION AND ELECTRONICS

### DISTRIBUTORS AND HARDWARE

#### A. Vacuum Advanced Electronic Distributors

Features a high-performance advance curve and an adjustable vacuum advance unit. Includes cap and rotor.

- <sup>1</sup> P3690431 Distributor, Vacuum Advance, Electronic, 383/400 Big Block
- <sup>1</sup> P3690432 Distributor, Vacuum Advance, Electronic, 426 Hemi/ 426 Wedge/ 413/ 440 Big Block
- <sup>1</sup> P3690430 Distributor, Vacuum Advance, Electronic, Small Block

#### B. Distributor, Electronic, Billet Aluminum

One-piece Billet Aluminum Electronic Distributors designed for street, bracket and oval track applications.

- <sup>1</sup> P5249775 Distributor, Billet Aluminum, Electronic, 426 Hemi / "RB" Engines
- <sup>1</sup> P5249776 Distributor, Billet Aluminum, Electronic, Small Block

#### C. Hold-Down Clamps, Distributor, Chrome

Under the hood every detail matters, and chrome is the perfect enhancement. Add to your underhood atmosphere with heavy-duty Chrome Distributor Hold-down Clamps and chrome-plated bolts. Sold individually.

- P4349279 Hold-Down Clamp, Distributor, Chrome, 426 Hemi/ Big Block
- P4349278 Hold-Down Clamp, Distributor, Chrome, Small Block

#### D. Distributor Advance Weight Springs

Use these Distributor Advance Weight Springs to convert stock distributor and Mopar Performance electronic distributors built prior to 2001 to quick advance curve. Package contains two springs.

- <sup>1</sup> P2932675 Weight Springs, Distributor Advance

#### E. Timing Curve Adjustment Kit

Kit contains six different primary springs, three different secondary springs and two degree key sets, allowing you to adjust timing to your performance needs. For use in parts: P3690426, P3690427, P3690428, P3690430, P3690431, P3690432, P5249775, P5249776, P5249777, P5249778, P5249779, P5249780. With detailed instructions.

- <sup>1</sup> P5153446 Timing Curve Adjustment Kit

Note: Timing curve adjustment kit . Fits most Mopar Performance distributors shipped after September 2004.

#### F. Distributor Cap and Rotor Sets

- P4876255AB Distributor Cap and Rotor, 1992-97 Dodge Truck Magnum/Jeep Engines, 5.2L/5.9L
- P5007856 Distributor Cap and Rotor, for Distributors P3690430-2, 426 Hemi/ Big Block/ Small Block and O.E.M Single Point and Electronic Distributors



A.



B. P5249776



C.



D.



E.



F.

DISTRIBUTORS AND HARDWARE

A. Distributor Cap, O.E. Replacement

Replacement for the original tan-colored distributor cap used in Chrysler high-performance V8 muscle cars of the late 1960s and early 1970s (sold individually).

**P4529791** Distributor Cap, Original Replacement, For Single Point Distributors, Big Block/Small Block

B. Intermediate Shaft Bushing

**P1737725** Intermediate Shaft Bushing, V6 and V8

C. Pickup Coil and Lead Assembly

Serves electronic and mechanical tach drive distributors.

**P5153576** Reluctor and Coil Pick Up, Used with Billet Aluminum Distributors

ELECTRONIC IGNITION SYSTEMS

D. Electronic Ignition Conversion Kits

Now available to convert old point-type ignitions to electronic ignitions. Modern magnetic impulse ignition systems have many advantages over breaker-type ignition systems. They require fewer tune-ups, increase secondary voltage, improve starting, eliminate irregular timing and dwell change with engine speed, and increase plug life. Packages include vacuum advance electronic distributor with high-performance advance curve, wiring harness, electronic control unit, ballast resistor and installation instructions.

<sup>1</sup> **P3690427** Electronic Conversion Kit, 383/400 Big Block

<sup>1</sup> **P3690428** Electronic Conversion Kit, 426 Hemi, 426 Wedge, 413/440 Big Block

<sup>1</sup> **P3690426** Electronic Conversion Kit, Small Block

E. Capacitive Discharge Ignition Controllers

Features a capacitive discharge technology that fires a series of multiple sparks for 20 degrees of crankshaft rotation when the engine is running under 3,000 rpm. This ensures complete combustion and produces great throttle response with a smooth idle. There's also an adjustable rev limiter (100 rpm increments) for overrev protection!

<sup>1</sup> **P5155516** Ignition Controller, Capacitive Discharge, V6/V8

F. Drag Race Ignition Controller

Features 14,000 rpm capability with built-in rev control (supplied with 7,000, 8,000, 9,000 rpm limits) and 115 millijoule spark energy. Produces 480-volt output on primary windings and is compatible with two- and three-step module selectors, timing controls and crank triggers. Can be used with Mopar Performance coils, P4876732, P4876733 or P4876734.

<sup>1</sup> **P4876731** Ignition Controller, MSD 7AL-2, Professional Drag Race, V8



A.

B.



C.

D.



E.

F.

## IGNITION AND ELECTRONICS

### ELECTRONIC IGNITION SYSTEMS

#### A. Orange Electronic Control Unit

For general high-performance use up through 6,000 rpm.

<sup>1</sup> P4120505 ECU, Orange Box, Hemi/ Big Block/ Small Block

#### B. Electronic Control Unit, Chrome

For a hotter spark, use this general high-performance control unit (up through 8,000 rpm).

<sup>1</sup> P4120534 ECU, Chrome, Hemi/ Big Block/ Small Block

#### C. Electronic Ignition Update Set

Contains lightweight advance springs to recurve the electronic ignition distributor for quicker spark advance and high-performance control unit. Kit includes P4120505 and P2932675 (Orange Electronic Control Unit and Spring Package).

<sup>1</sup> P4007968 Electronic Ignition Update Set, Hemi/ Big Block/ Small Block

#### D. Control Unit Wiring Harness Kit

Use this harness to service a missing or worn ECU-to-distributor harness.

P3690152 Wiring Harness, Control Unit, For Electronic Ignitions, Hemi/ Big Block/ Small Block

#### E. Ignition Switch

If your ignition switch needs replacing, don't install an old, used piece. Replace it with a brand-new unit from Mopar. This ignition switch is an exact reproduction and it perfectly replaces your old unit with no modifications necessary.

03747092 Ignition Switch, 1970-74 B/C/E-Body, 1970-76 A-Body

### BALLAST RESISTORS

#### F. Ballast Resistor, Dual

The sharpest eyes will spot the correct ballast resistor on a restoration project. This Mopar Ballast Resistor is a reissued factory original as used on 1972 and later OEM electronic ignitions with four-pin dual ballast resistors.

<sup>1</sup> P4529795 Ballast Resistor, Dual, Restoration

#### G. Ballast Resistors - Electronic Distributor

<sup>1</sup> P5206436 Ballast Resistor, For Electronic Ignition Systems, Using P4120505 Orange Box and Production Coil, or With P4120889 Coil, 1 OHM

<sup>1</sup> P2444641 Ballast Resistor, for Mechanical Advance Distributor, Using P3690560 and P4876832/33 Coils, 1/4 OHM, Race Only



A.



B.



C.



D.



E.



F.



G.

**IGNITION WIRES AND SPARK PLUGS**

**A. Ignition Wire Set - 8 mm**

Mopar's custom Ignition Wire Set is specifically made for high-performance use. It features a suppression core for general high-performance applications. Wires are blue with the Mopar name imprinted along the wire. Use P4529032, plus eight heat-resistant insulators and boots (P4120808) on Hemi engines.

**P4529032** Wire Set, Spark Plug, 8 mm, Suppression Core, Hemi/ Big Block/ Small Block

**B. Ignition Wire Sets - 8 mm, Pre-Cut**

These pre-made Ignition Wire Sets are designed with factory-attached cap and plug ends. They are constructed with either a radio suppression core for high-performance street use or a metallic core for racing applications. Wrapped in 8 mm heat-resistant insulation to maintain maximum voltage.

**P5007408** Wire Set, Spark Plug, 8 mm, Metallic Core, Big Block

**P5007407** Wire Set, Spark Plug, 8 mm, Radio Suppression Core, Big Block

**P5007405** Wire Set, Spark Plug, 8 mm, Radio Suppression Core, Small Block

**C. Ignition Wire Sets - 7.5 mm, Pre-Cut**

Pre-cut, high-performance 7.5 mm Ignition Wire Sets specifically designed to maintain compatibility with the onboard computers and electronics found on production vehicles. Each package contains high-tech-style boot ends at both the distributor and plug ends of the wire. These blue wires are Imprinted with the Mopar name and the cylinder number.

**P4876436** Wire Set, Spark Plug, 7.5 mm, 1991-02 4.0L Jeep Engines

**P4876432** Wire Set, Spark Plug, 7.5 mm, 1992-03 5.2L/5.9L Truck Magnum/Jeep Engines, 2 5/8" Long boot

**P4876434** Wire Set, Spark Plug, 7.5 mm, 1994-02 8.0L Ram

**P4876437** Wire Set, Spark Plug, 7.5 mm, 1996-00 2.5L Dakota and Wrangler

**P4876775** Wire Set, Spark Plug, 7.5 mm, 426 Hemi

**P4876433** Wire Set, Spark Plug, 7.5 mm, 5.2L/5.9L Truck Magnum/Jeep Engines (1992-03) 1 7/8" Short boot

**D. Ignition Wire Set, Restoration**

Just like O.E., carbon suppression wires are manufactured in the right color with the right lettering and each includes the correct spark plug boot. Set contains eight ignition secondary wires and one coil wire.

**P4529792** Wire Set, Spark Plug, Orange, 1971 & Prior 383/440 Big Block, Restoration.

**P4529797** Wire Set, Spark Plug, Orange, 340 Small Block, Restoration

**E. Ignition Wire Separator Set**

Includes eight pieces. Fits 7.5 mm wire.

**P4007667** Wire Separator, Spark Plug, Set of eight (8).



A.



B.



C.



D.



E.

RESTORATION

## IGNITION AND ELECTRONICS

### IGNITION WIRES AND SPARK PLUGS

#### A. Insulator and Boot Kit, Hemi

Kit to service one cylinder (eight required per engine). Use with 8 mm ignition wire set P4529032.

**P4120808** Insulator and Boot Kit, Hemi

#### B. Plug Tube and Seal Set

Includes eight special spark plug tubes and tube seals, as used on 426 Hemi engines.

**P4120294** Plug Tube and Seal Set 426/ 472/ 528 Hemi

#### C. Spark Plug Wire Removal Tool

Here's the tool you need for easy removal of spark plug wires without pulling the wire out of the terminal end and boot.

**P5249718** Spark Plug Wire Removal Tool

#### D. Universal Fit Spark Plug Wire Loom

Works with 7 mm or 8 mm wire. Includes four 1/4" mounting studs (20 tpi). Not for use with cast aluminum valve covers.

**P5007481** Loom, Spark Plug Wire, Universal Fit

#### E. Spark Plugs

Bosch Motorsports Spark Plugs are specifically designed for optimal performance of your Mopar engine. Sold in sets of four.

**P4876926** Spark Plug, FR 8 DCX, Hemi/ Small Block

**P4876927** Spark Plug, WR 9 FC, Big Block

## COILS

#### F. Ignition Coil, Restoration

For you purists out there, Mopar offers this Restoration Ignition Coil. An exact reproduction of the original factory black unit, right down to the vintage Mopar logo. If your coil is over ten years old, replace it with this brand-new piece.

**02495531** Coil, Ignition, Black with Vintage Mopar Logo, 1972-78 Small-Block/Big-Block/Hemi, Restoration

#### G. Blaster Coils

These high-performance cylindrical Blaster Coils are oil-filled. They feature 100:1 turns ratio, threaded-stud primary connection and conventional "socket-style" tower. Designed for high-performance street and race applications. Use 1/4-ohm ballast resistor P2444641 when used with ignition kits P3690426, P3690427, P3690428.

<sup>1</sup> **P5155514** Coil, Blaster, Black, for Controllers P4876728-29, V8

<sup>1</sup> **P5155515** Coil, Blaster, Chrome, for Controllers P4876728-29 and P4876731 (V8)



A.



B.



C.



D.



E.



F.



G.



COILS

**A. Ignition Coil, High Performance**

For all 12-volt applications. Not recommended for engine speeds over 6,500 rpm. Use 1-ohm ballast resistor P5206436.

<sup>1</sup> P4120889 Coil, Ignition, Super, Hemi/ Big Block/ Small Block

**B. Pro Power Coil**

Features a unique design shape that is potted with urethane and special windings for fast rise time characteristics required for high rpm. Designed for short drag race applications only. Use with Drag Race Ignition Controller (P4876731).

<sup>1</sup> P4876734 Coil, Blaster, Pro Power, Race V8

**C. Ignition Coil, Race**

Specifically designed to be used with race-only electronic ignition kits. Not recommended for continued operation at speeds below 3,000 rpm for more than 30-minute periods. Use 1/4-ohm ballast resistor P2444641.

<sup>1</sup> P3690560 Coil, Ignition, Race, V8

**D. Coil Bracket**

Another underhood piece to dress up your engine compartment. Includes a special clamp screw.

<sup>1</sup> P4286728 Coil Bracket, Chrome, V8 and 6-cyl

STARTERS

**E. Lightweight Starters**

These specially-designed starter motors with heavy-duty features for V8 applications need no adapters. Weighing approximately 7 lbs. complete, these units are lighter than the previous Mopar Performance lightweight starter, half the weight of the original 1960s-70s vintage production starter, and one inch shorter. May require header/exhaust/block modifications on some applications.

<sup>1</sup> P5007860AB Starter, Lightweight, 426 Hemi/ Big Block

<sup>1</sup> P5249644AC Starter, Lightweight, Small Block

VOLTAGE REGULATORS

**F. Voltage Regulator, Constant Output**

To ensure your ignition and electrical systems can provide maximum performance, install a Mopar Constant Output Voltage Regulator. Voltage is held at a constant 13.5 volts. For race applications only.

<sup>1</sup> P3690731 Voltage Regulator, Constant Output, 1970 and Newer V8, Race

<sup>1</sup> P3690732 Voltage Regulator, Constant Output, to 1969, Race



A.



B.



C.



D.



E.



F.

## IGNITION AND ELECTRONICS

### VOLTAGE REGULATORS

#### A. Voltage Regulators

For restoration or repair, Mopar offers this factory reissue of the Voltage Regulator as used on muscle cars of the early 1970s. The regulator is black with the original Mopar part number imprinted in yellow. Contains modern electronics.

<sup>1</sup> 77R06285 Voltage Regulator, 1970, Restoration

<sup>1</sup> 77R06286 Voltage Regulator, 1971, Restoration

<sup>1</sup> P4529794 Voltage Regulator, Muscle Car, O. E.

#### B. Tach Adapter

Designed for applications when high-capacitive discharge coils interfere with tachometer or fuel injection signals. Provides a clear 12-volt square wave signal output with a 30% duty cycle.

P4876738 Tachometer Adapter, V8

#### C. Tach Adapter

Designed for applications when high-capacitive discharge coils interfere with tachometer or fuel injection signals. Provides a clear 12-volt square wave signal output with a 30% duty cycle.

P4876738 Tachometer Adapter, V8

## IGNITION AND ELECTRONICS

#### D. Engine Wiring Harness- 360 Magnum

<sup>1</sup> P5153687 Wiring Harness, Service part for 360 Fuel Injection Kits

## ALTERNATORS

#### E. Alternator Brackets

P2206445 Alternator Bracket, 426 Hemi/ Big Block

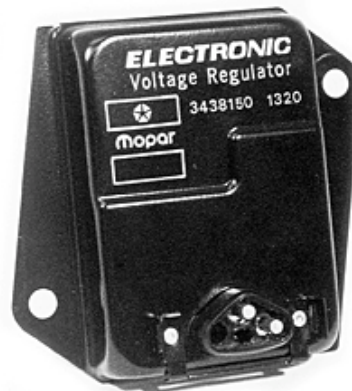

A. P4529794



B/C.

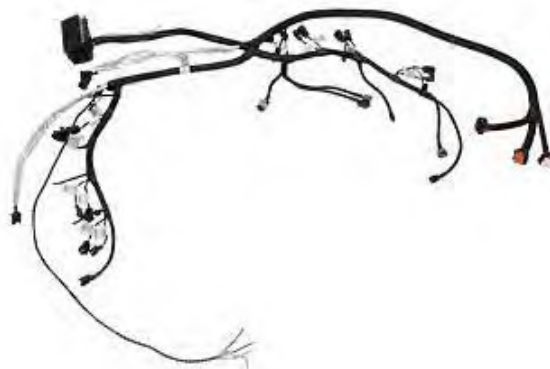

D.



E. P2206445

# AUTOMATIC TRANSMISSION .07



P  
R  
E  
P  
A  
R  
E  
D  
F  
O  
R  
M  
A  
T  
I  
O  
N  
S

## AUTOMATIC TRANSMISSION

### FLEX PLATES AND HARDWARE

#### A. Flex Plates - 7/16" Bolts

- <sup>1</sup> P5153795 Flex Plate, Non-SFI-approved for use with eight-bolt Crank Flange
- <sup>1</sup> P5153753 Flex Plate, SFI-approved for use to adapt 727/904 type automatic transmissions to the new 5.7L, 6.1L and 392 Hemi blocks, 7/16" Bolts
- <sup>1</sup> P4529752AB Flex Plate, SFI-approved for use with eight-bolt Crank Flange
- <sup>1</sup> P4529751AB Flex Plate, SFI-approved for use with six-bolt Crank Flange

#### B. Flex Plates - 5/16" Bolts

This weighted, externally balanced Torque Converter Flex Plate is for use with econo/lockup torque converters.

- <sup>1</sup> P4876706 Flex Plate, RWD, 1996-2003 5.9L Dodge Truck Magnum/Jeep Engines, Can be used with SEFI symmetrical bolt pattern
- <sup>1</sup> P4876821 Flex Plate, RWD, 6-Bolt Crank, V8 To 1991
- <sup>1</sup> P5007378 Flex Plate, RWD, 8-Bolt Crank, Stroker Cranks
- <sup>1</sup> P5155427 Flex Plate, RWD, Butterfly, 727/904 Transmissions, No Ring Gear, Requires Converters with Integral Ring Gears, Drilled for Both Patterns Even, and Offset, 5.7/ 6.1/ 392 Hemi, 5/16" Bolts

#### C. Flex Plate Screw Package

Includes six crank screws and four converter screws.

- <sup>1</sup> P4876820 Screws, Flex Plate, Six-bolt Crank, 5/16" Converter, Hemi/Big Block/ Small Block/ Slant Six, 3.9L V6

## SHIFTERS AND SHIFT IMPROVEMENT KITS

#### D. RWD Shift Improver Packages

Enjoy firmer, quicker shifts with these Shift Improver Packages. On 1971-86.5 A-727/A-904 transmissions, the part-throttle kickdown is retained. For general purpose or high-performance use.

- <sup>1</sup> P4349469AB Shift Improver Package, to 1986 1/2, A-727
- <sup>1</sup> P4007899 Shift Improver Package, to 1986 1/2, A-904/ A-998/ A-999

## AUTOMATIC TRANSMISSION COMPONENTS

#### E. Valve Body Assembly

Get manual shift turbo action. RWD Valve Body Assembly eliminates 2-3 shift overlap. Fits all 1966-76 Mopar transmissions and 1966-83 non-lockup, reverse pattern. For race use only.

- <sup>1</sup> P4007291 Valve Body Assembly, 1966-83, A-727, A-904



A. P4529752AB



B. P4876706



B. P4876821



C.



D.

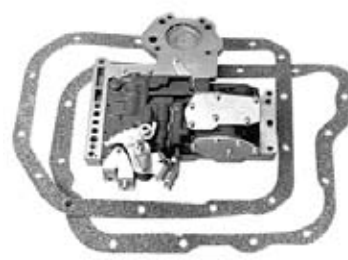

E.

**AUTOMATIC TRANSMISSION COMPONENTS**

**A. Transmission Neutral Safety Switch**

- P2932820 Neutral Safety Switch, Transmission, 1969–84 A-727 and A-904 Torqueflite applications (Long)
- P5007747 Neutral Safety Switch, Transmission, 3-Prong, 1985-Present A-727/A-904, (Short)

**B. Transmission Lockup Solenoid Connector**

When removing or installing an automatic transmission, the Lockup Solenoid Connector can become damaged or broken. Not to worry! Mopar now carries this previously hard-to-find replacement part for your A-727 or A-904 automatic transmission.

- <sup>1</sup> P4348719 Lockup Solenoid Connector, Transmission, 1967–78 A-727 and A-904

**C. Kickdown Lever**

This special 5:1 ratio Kickdown Lever can be used as a replacement on the 426 Hemi® transmission. Speeds up front band actuation on other A-904 and A-727 transmissions to firm upshifts.

- <sup>1</sup> P4529023AB Kickdown Lever, A-904/A-727

**D. Kickdown Cable**

For engine and transmission swaps when production kickdown linkage will not work or is not available.

- <sup>1</sup> 77R06161 Kick Down Cable, Torqueflite, Kit
- <sup>1</sup> P4510645 Kickdown Cable, Single 4-bbl Applications

**E. Automatic Transmission Filter Spacer**

Extruded aluminum Automatic Transmission Filter Spacer for RWD applications. One inch thick and machined with O-ring groove and three mounting screw holes.

- <sup>1</sup> P4510054 Filter Spacer 1.00", Automatic Transmission

**F. Transmission Plug and Cap Package**

Package contains plastic plugs and caps to prevent unwanted dust and dirt from getting into a transmission during storage or transport.

- P4120280 Plug and Cap Package, Transmission, A-500/ A-518/ A-727/ A-904/ A-998/ A-999

**G. Front Clutch Piston Spring**

When rebuilding your A-727 transmission, you should always replace the Front Clutch Spring. This spring provides the correct amount of tension to ensure firm upshifts and prolonged clutch life. Sold individually.

- <sup>1</sup> P2801243 Spring, Front Clutch, A-727



A.



B.



C.



D. 77R06161



E.



F.



G.

## AUTOMATIC TRANSMISSION

### AUTOMATIC TRANSMISSION COMPONENTS

#### A. Clutch Kits

Dual-purpose performance A-904 (includes A-998, A-999 and A-500) or A-727 transmissions can be fixed with these complete Clutch Kits. All components are high-quality O.E. parts designed for your transmission. Kits contain front and rear discs, clutch plates and instructions.

<sup>1</sup> P4529016 Clutch Kit, A-727

<sup>1</sup> P4529008 Clutch Kit, A-904/A-500

#### B. Front Bands

Mopar takes the same high-quality, heavy-duty transmission Front Bands found in our complete A-904 or A-727 transmission kits, but packages them separately for your convenience. Select either dual-purpose performance or race applications.

<sup>1</sup> P4529020 Band, Flex, Front, RWD, A-727, Race

<sup>1</sup> P4529017 Band, Solid, Front, RWD, A-727, Performance

## TRANSMISSION OVERHAUL KITS

#### C. Transmission Overhaul Kits, Performance

Packages include factory original equipment transmission seals, filters, gaskets, rings, bands and discs.

<sup>1</sup> P5007843 Overhaul Kit, Transmission, Heavy Duty, 1987-97 A-500

<sup>1</sup> P5007845 Overhaul Kit, Transmission, Heavy Duty, 1990-97 A-518/A-618

<sup>1</sup> P5007844 Overhaul Kit, Transmission, High Performance, 1987-97 A-500

#### D. Transmission Overhaul Kits, General Purpose

Intended for general purpose street or drag strip usage. Friction materials are factory-quality, O.E. parts manufactured through Raybestos. Adequate for dual purpose applications. Low/reverse band is not included, since wear is usually minimal and does not require replacement.

<sup>1</sup> P5007172 Overhaul Kit, Transmission, A-727

<sup>1</sup> P5007568 Overhaul Kit, Transmission, A-904/A-500

#### Transmission Overhaul Kits, Race (Not Shown)

Recommended for strip use only. Aggressive Kevlar-lined front drum flex band (steel drum only) and Raybestos blue plate special racing front and rear clutch plates distinguish these from general performance overhaul kits.

<sup>1</sup> P5007171 Overhaul Kit, Transmission, Race, A-727

<sup>1</sup> P5007569 Overhaul Kit, Transmission, Race, A-904/A-500

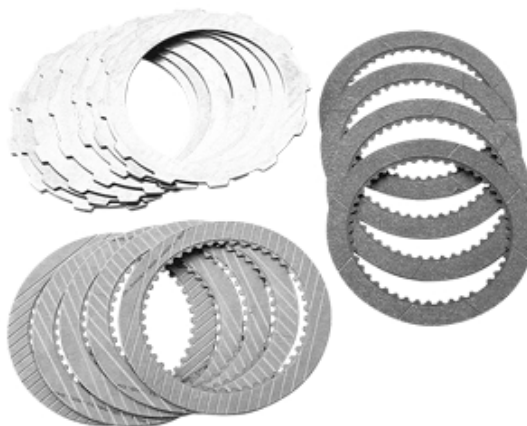

A.



B.



C.



D.

**TRANSMISSION PANS AND HARDWARE**

**A. Transmission Attaching Bolts, Chrome**

Fits all automatic transmission assemblies.

**P4452785** Bolt Package, Chrome, A-904/ A-727/ A-500/ A-518



A.

**B. Transmission Gasket and Filter Packages**

All the parts you need for changing the fluid in your automatic transmission.

**P4120461** Filter and Gasket, Transmission, Automatic, A-727

**P4120462** Filter and Gasket, Transmission, Automatic, A-904/A-999

**P3690855** Gasket, Transmission, A-727



B.

**C. Cast Aluminum Deep Oil Pan Packages**

Extra-capacity Cast Aluminum Deep Oil Pans improve the cooling and lubrication of critical transmission components, for better shift performance and longer component life. A new, redesigned billet bolt-on spacer is provided to lower the fluid pickup. Adds two quarts to sump. Includes drain plug and extra hole for temperature gauge (plug required if gauge is not used).

**P5007740AB** Oil Pan, Cast, 3.90" Deep, 1990-2001 A-518

**P5007793AB** Oil Pan, Cast, 3.90" Deep, A-727

**P5007795AB** Oil Pan, Cast, 4.50" Deep, 1989-2001 A-500



C.

**D. Stamped Steel Deep Oil Pan Packages**

Extra-capacity stamped steel oil pans improve the cooling and lubrication of critical transmission components, for better shift performance and longer component life. A new, redesigned billet bolt-on spacer is provided to lower the fluid pickup. Includes drain plug.

**P4120161AB** Oil Pan, Deep, Chrome-Plated, A-727

**P3690730AB** Oil Pan, Deep, Stamped Steel, A-727

**P4007886AB** Oil Pan, Deep, Stamped Steel, A-904/A-999



D.

**E. Transmission Filter Extension Kit**

For use with Automatic Transmission Deep Pan Packages. Kit contains one filter extension, one transmission pan gasket, and one transmission fluid filter.

<sup>1</sup> **P5249321AB** Filter Extension Package, A-727



E.

**TORQUE CONVERTERS AND HARDWARE**

**F. Balance Weight and Positioning Template Package**

Required for rebalancing performance torque converters. For use with externally balanced cast iron cranks.

**P5249843** Balance Weight and Positioning Template Package, 5.9L Truck Magnum/Jeep Engines

**P4120241** Balance Weight and Positioning Template, Package 1971-91 440 Six Pack, 1971-92 360, not Magnum



F.

## AUTOMATIC TRANSMISSION

### TORQUE CONVERTERS AND HARDWARE

#### A. Torque Converter Bolt Set

Includes four bolts to attach torque converter to the flex plate. Available for both eight- and six-cylinder engines.

- P4529591 Bolt Package, Torque Converter, 5/16", V8 and Six Cylinder
- P4529592 Screws, Torque Converter to Flex Plate, 7/16", 426 Hemi, Set of Four

#### B. Torque Converters, Lockup

These performance Torque Converters have higher stall speeds than production units, but aren't as expensive as aftermarket race units. The higher stall speed offers better throttle response and a quicker launch.

- <sup>1</sup> P4529403AB Torque Converter, Lockup, 1900-2100 Stall Speed, 1967-92 A-904
- <sup>1</sup> P5007291AB Torque Converter, Lockup, 1900-2100 Stall Speed, 1993-96 A-904
- <sup>1</sup> P5007293AB Torque Converter, Lockup, 1900-2100 Stall Speed, 1996 and newer A-500
- <sup>1</sup> P5007298AB Torque Converter, Lockup, 1900-2100 Stall Speed, A-518
- <sup>1</sup> P4876947AB Torque Converter, Lockup, 1900-2100 Stall Speed, A-727
- <sup>1</sup> P5007292AB Torque Converter, Lockup, 2250-2350 Stall Speed, 1993-96 A-904
- <sup>1</sup> P5007294AB Torque Converter, Lockup, 2250-2350 Stall Speed, 1996 and newer A-500

#### Torque Converters, Econo (Not Shown)

- <sup>1</sup> P4876805AB Torque Converter, Econo, 1900-2100 Stall Speed, 1967-92 A-904



A.

---



B. P4529403AB

---



# MANUAL TRANSMISSION .08



PERFORMANCE

27-11-1996 11:29

## MANUAL TRANSMISSION

### FLYWHEELS AND HARDWARE

#### A. Flywheel- Cast

Replacement flywheel for 1971-1992 360 cast crank engine with external balance. Not SFI- approved. Six-bolt for 10.50" clutch.

<sup>1</sup> P4529110 Flywheel, Cast Crank, 130-Tooth, 1971-92 360 "A" Engines, Not 360 Magnum

<sup>1</sup> P5249842 Flywheel, Cast Crank, 130-Tooth, 1993-03 5.9L Dodge Truck Magnum/Jeep Engines

#### B. Flywheel- Steel- Race

Race Steel Flywheel weighs 18 1/2 lbs. and is designed for use with 10 1/2" clutch.

<sup>1</sup> P4876047 Flywheel, Steel, Race, 6-Bolt, Big Block/Small Block

#### C. Flywheel- Steel

Steel Replacement Flywheels weigh 30 lbs. and are for use with 10 1/2" clutch.

<sup>1</sup> P4529142 Flywheel, Steel, 6-Bolt, 130-Tooth, Big Block/ Small Block

<sup>1</sup> P4529143 Flywheel, Steel, 8-Bolt, 130 Tooth, Big Block/ Small Block Gen II Hemi

#### D. Flywheel Hardware Kit

Ideal for Inline 6 and 90° V6 and V8 engines. Includes six crankshaft and pressure plate bolts.

P4529113 Hardware Kit, Flywheel, 6-Bolt, V8 and 6-cyl.

Note: Not to be used as an OEM replacement for production 5.7L/6.1L hardware.



A.



B.



C.



D.

## BELL HOUSING

### A. Bell Housing, SFI

This hydroformed SFI Bell Housing can be used with A-833 four-speed or Tremec TKO transmissions. Both hydraulic and mechanical Mopar clutch linkage systems can be used, either with the stock "Z-bar" design, or the hydraulic clutch components listed below. Comes with the bell housing, backing plate, all fasteners, pivot ball and pilot bearing.

<b>P5153602</b>	Bell Housing, SFI, 5.7L/6.1L Hemi, All Magnum (carb) and LA Small Block Engines
<b>52107555</b>	Clutch Fork
<b>52107625</b>	Clutch Master/Slave Assembly
<b>52087542</b>	Pivot Ball
<b>53008342</b>	Release Bearing
<b>04338855</b>	Spring, Clutch Release Fork

Note: Some modifications will be necessary to adapt a hydraulic system to your vehicle.

## CLUTCH DISCS, PRESSURE PLATES AND HARDWARE

### B. Clutch Fork Replacement Kits

For manual transmission clutch forks. Kits contain a clutch fork and boot. Clutch fork pivot not included.

<b>P4529453</b>	Clutch Fork Repair Kit, 10-3/4" Approx. Length, "B" Engine B/E-Bodies
<b>P4529452AB</b>	Clutch Fork Repair Kit, 10-3/4" Approx. Length, Small Block, B/E-Bodies
<b>P4529451</b>	Clutch Fork Repair Kit, 12-1/2" Approx. Length, Small Block, A-Body, Except 1976

### C. Clutch Linkage Shaft Service Kits

Complete kits to restore the clutch shaft linkage from the clutch pedal to the clutch fork on RWD manual transmissions. Each kit contains nylon bearings, snap rings, seals, washers, lock springs, pivot ball studs and instructions.

<b>P4529489</b>	Clutch Linkage Shaft Service Kit, A-Body
<b>P4529447</b>	Clutch Linkage Shaft Service Kit, B/E-Bodies



A.



B.



C.

Questions? Call the Mopar Direct Connection Techline at 1-888-528-HEMI (4364)

<sup>1</sup> Not legal on pollution-controlled vehicles or vehicles registered for highway use.

## MANUAL TRANSMISSION

### CLUTCH DISCS, PRESSURE PLATES AND HARDWARE

#### A. Clutch Rod Repair Kits

Repair kits for the clutch rod that runs from the clutch linkage to the clutch fork. Each kit contains a clutch rod, nuts, washers, springs, clips and instructions.

- P4529450 Clutch Rod, 4.880" Overall Length, Big Block, B/E-Bodies
- P4529448 Clutch Rod, 6.885" Overall Length, Small Block, A-Body

#### B. Clutch Cover and Pressure Plate - Race

Super heavy-duty for 3,100-lb. spring load.

- <sup>1</sup> P4529406 Race Clutch Cover and Pressure Plate, Race, 10-1/2", Hemi/Big Block/Small Block

#### C. Pressure Plates- Street & Strip

Designed as replacements for early V8 muscle cars. Roller design similar to original production units. Use with Muscle Car Clutch Discs.

- <sup>1</sup> P4529140 Pressure Plate, 10-1/2", 2,500 lb. Base, Dodge and Plymouth V8 Muscle Cars
- <sup>1</sup> P4876919 Pressure Plate, 11" (10.95"), 2,750 lb. Base and 143 Tooth Flywheel, 1970 and Later Hemi, 426 Hemi/ 440 Big Block
- <sup>1</sup> P4529141 Pressure Plate, Scalloped Muscle Car, 10.5" Bolt Pattern, 10.95", 2,500 lb. Base, 1970-72 Hemi/Big Block

#### D. Muscle Car Clutch Discs

Designed as replacements for various Dodge and Plymouth V8 muscle cars. Use with Mopar Muscle Car Pressure Plates (P4529140 and P4529141).

- P4529138 Clutch Disc, 10-1/2", 18-Spline, Dodge and Plymouth V8 Muscle Cars
- P4529136 Clutch Disc, 10-1/2", 23-Spline, Dodge and Plymouth V8 Muscle Cars
- P4529139 Clutch Disc, 11" (10.95"), 18- Spline, Dodge and Plymouth V8 Muscle Cars
- P4529137 Clutch Disc, 11" (10.95"), 23-Spline, Dodge and Plymouth V8 Muscle Cars

#### E. Clutch Release Roller Bearing/Sleeve Assembly

It is recommended that you replace your throw-out bearing every time you replace your clutch. This Clutch Release Roller Bearing and Sleeve Assembly applies to four-speed transmissions with 10.50" clutch. Fits only 18-spline input shaft, A-833 transmission.

- <sup>1</sup> P4529064 Clutch Release Roller Bearing and Sleeve Assembly



A.



B.



C.



D.



E.



A.



B.



C.



D. P3467766

## CLUTCH DISCS, PRESSURE PLATES AND HARDWARE

### A. Four-Speed Front Bearing Retainers

Mopar has re-released these A-833 Four-Speed Front Bearing Retainers. No more scouring the salvage yards for the correct one. Whether you are swapping transmissions or restoring a legend, you can choose the correct bearing retainer for your application. Each package includes the retainer, retainer gasket and input shaft seal. Bearing retainers are identified by their outside diameter (OD), attaching bolt circle diameter (BC) and corresponding transmission input shaft.

- P4529694** Retainer, Bearing, 4.35" O.D., 3.70" BC, for 23-Spline Input Shaft, A-833
- P4529695** Retainer, Bearing, 4.80" O.D., 3.70" BC, for 23-Spline Input Shaft, A-833
- P4529697** Retainer, Bearing, 4.80" O.D., 4.16" BC, for 18-Spline Input Shaft, A-833
- P4529696** Retainer, Bearing, 4.80" O.D., 4.16" BC, for 23-Spline Input Shaft, A-833

### B. Pilot Bearing

The Pilot Bearing should always be replaced when servicing the clutch and throw out bearing, or whenever a new clutch is installed.

- P4876056AA** Pilot Bearing, 5.2L/5.9L Dodge Truck Magnum/Jeep Engines
- P5007051** Pilot Bearing, Big Block and Small Block

## SHIFTERS AND SHIFT IMPROVEMENT KITS

### C. Hurst Pistol Grip Shifters

Offered exclusively through Mopar, Hurst Pistol Grip Shift levers are back! Give your four-speed Mopar muscle car that original look and feel it deserves with these brand-new, factory reissued pistol grip shift levers from Hurst. All pistol grip sticks are the bolt-in style and are designed for use with Hurst Comp Plus Shifter (part number 391-6769, not available through Mopar).

- P4510948** Shifter, Hurst Pistol Grip, 1970 B-Body with Console
- P4510612** Shifter, Hurst Pistol Grip, 1970-74 E-Body, 1971-74 B-Body with Console
- P4510611** Shifter, Hurst Pistol Grip, 1971-74 B-Body Non-Console with Center Arm Rest
- P4510610** Shifter, Hurst Pistol Grip, All 1968-69 Non-Console, 1970 B-Body Non-Console
- P4510614** Insert, Shifter, Hurst Pistol Grip, Simulated Wood Grain

### D. Shifter Boot

If your shifter boot is damaged, worn, or missing, we've got you covered. This quality reproduction looks great and uses the same materials as the original production unit.

- 03467764** Shifter Boot, 1967-76 Dart/Demon/Duster
- P3467766** Shifter Boot, 1970-74 'Cuda/Challenger, 1971-74 Road Runner/GTX and Charger



# DRIVETRAIN & REAR AXLE COMPONENTS .09



PERFORMANCE

27-11-1994 11:29

## DRIVETRAIN AND REAR AXLE COMPONENTS

### UNIVERSAL JOINT AND YOKE KITS

#### A. Axle Yoke Kits

Complete driveshaft pinion yoke kits include yoke, U-joint retaining straps, strap hold-down bolts, yoke retaining washer and nut, and instructions.

**P4876804** Axle Yoke, 10 Spline, 7290 Joint, Dana 60 Axles, 8-3/4"

**P4529483AB** Axle Yoke, 29 Spline, 7290 Joint, 8-3/4" Axles

29 spline Dana and 8 3/4 yokes are not interchangeable.

#### B. Yoke Kits, Billet

For use with 742 or 489 housing or Mopar Performance aluminum housing (P4876445). Kits include U-bolts and pinion nut.

**P4510656** Axle Yoke, 10 Spline, 1.078" Bearing Cap, 4130 Chrome Moly Billet, 8-3/4" Axles

**P4510638** Axle Yoke, 10 Spline, 1.078" Bearing Cap, Aluminum Billet, 8-3/4" Axles

**P4510657** Axle Yoke, 10 Spline, 1.125" Bearing Cap, 4130 Chrome Moly Billet, 8-3/4" Axles

**P4510655** Axle Yoke, 10 Spline, 1.125" Bearing Cap, Aluminum Billet, 8-3/4" Axles

#### C. Slip Yoke Kits

For use with driveshaft kits or general service.

**P5007409** Slip Yoke Kit, Type 7260 U-Joint, 26 Spline, 6.80" Long, A-904

#### D. Universal Joint Packages

U-joint for driveshaft use.

**P3690773** U-Bolt Assembly Package, Universal, 1330 Series

#### E. U-Bolt Conversion Kit

**P4120714AB** U-Bolt Conversion Kit, Adapts 7290 Driveshaft to a U-Bolt style Yoke, Dana 60 Axles w/o dust shield. Use with 7290 U-Joint (not included).

Kits do not include U-Joint or U-Bolts. Allows the use of stock prop shaft.

#### F. U-Joint U-Bolt Service Package

Serves U-Bolt Conversion Kit. Two required.

**P3690774** U-Joint and U-Bolt Service Package, Dana 60 Axles

#### G. U-Joint Strap and Bolt Set

This inexpensive package will help you avoid potential driveshaft failure and give you peace of mind. Use with Dana 60 Axle Yoke Kit (P4876804).

**P4120468** U-Joint Strap and Bolt Package, 7260, 8-1/4" and 8-3/4" Axles

**P4120469** U-Joint Strap and Bolt Package, 7290, 8-3/4" and Dana 60 Axles



A.



B.



C.



D.



E.



F.



G.



REAR AXLE COMPONENTS

A. Ring and Pinion Sets

These high-performance rear end Ring and Pinion Gears are manufactured with a special heat treat process. They are made with the special needs of drag race and off-road competition in mind.

<sup>1</sup> **P5249927AB** Ring and Pinion Gears, Rear Axle, 3.55:1 Ratio, 12-Bolt Cover, 9 1/4" Axles

B. Aluminum Carrier Housing

Designed to reduce weight and hold up under high torque. Uses 1-3/4-inch large stem pinion and standard components. The 8-3/4-inch aluminum axle housing uses "742-style" large stem ring and pinions and fits 8-3/4-inch banjo housings (up to 1974). It features a weight reduction of 44% (approximately 11 lbs. to 14 lbs.), compared to production cast iron housing, and includes 6061 billet aluminum caps. It is stiffer than cast iron, and decreases pinion deflection by 10%. It uses "742-style" bearings and shims, service parts and sure-grips. Clearance required on 3.23:1 or higher ratios. Adjuster lock bolts may need to be replaced with socket head bolts.

**P4876445** Carrier Housing, Aluminum, 8-3/4" Axles

**P5007239** Gasket, Carrier Housing, 8-3/4" Axles

C. Axle Brace

Keeps axle tubes from twisting under extreme loads, and provides strength and rigidity to Chrysler 8-3/4-inch axles. Welding required.

**P4510642** Axle Brace, 8-3/4" Axles

D. Differential Clutch Kits

O.E. clutch discs and plates to rebuild a limited slip differential.

**P4529484** Differential Clutch Kit, 8-3/4" Axles

**P4529485** Differential Clutch Kit, 9-3/4" Axles

E. Bearing Set, Rear Axle

Specifically designed by Mopar to eliminate production bearing retainers and axle end play adjuster. Set contains two axle shaft bearings, two bearing retainer sleeves, two axle shaft seals and two axle flange gaskets. For drag racing use only.

**P5249444** Bearing Set, Rear Axle, 1965 and Newer 8-3/4" and 9-3/4" Axles

F. Crush Sleeves

Original equipment Crush Sleeves for setting up rear axle. Includes pinion nut washer and pinion flange nut.

**P4529700** Crush Sleeve, 8-1/4" Axles

**P4529702** Crush Sleeve, 9-1/4" Axles



A.



B.



C.



D.



E.



F.

## DRIVETRAIN AND REAR AXLE COMPONENTS

### REAR AXLE COMPONENTS

#### A. Ring Gear Retaining Bolt Set

Complete set of 12 bolts with instructions.

- P5249163** Bolt Package, Ring Gear, Left-Hand Thread, to 1970: 7-1/4" and 8-3/4"; to 1971: 8-1/4" Axles
- P4529486** Bolt Package, Ring Gear, Right Hand Thread, 1971-on: 7-1/4" and 8-3/4" Axles, 1972-on: 8-1/4" Axles



### DIFFERENTIAL COMPONENTS

#### B. Sure-Grip Differential Assemblies

Mopar supplies production replacement Clutch-Type Sure-Grip Differential Assemblies for rear axles. These assemblies are complete for high-performance applications. Designed for gear ratios of 2.76:1 and higher.

- P4876118** Differential Assembly, Sure Grip, 8-3/4" Axles

#### C. Differential Covers, Chrome

Impress those behind you with a Mopar Chrome Differential Cover. Attaching bolts not included.

- P3690753** Cover, Differential, Chrome, RWD, 8-1/4" Axles
- P3690754** Cover, Differential, Chrome, RWD, 9-1/4" Axles, 1973 and Newer
- P3690755** Cover, Differential, Chrome, RWD, 9-3/4" Dana 60 Axles

A.

B.

#### D. Bolt Set, Differential Cover

Chrome Attaching Bolt packages for Chrome Differential Covers.

- P4452787** Bolt Set, Chrome, 7-1/4", 8-1/4", 9-1/4" Axles, 12 Pcs.
- P5249719** Bolt Set, Chrome, 9 3/4" Dana Axles, 10 Pcs.



C.

D.

#### E. Shim Package, Rear Axle

An incorrect rear axle pinion angle not only robs precious horsepower, but can also cause launch problems and parts failure. Mopar has developed these tapered pinion angle shims so the pinion-to-driveshaft angle can be adjusted to the correct 5 to 7 degrees (for drag racing only), to less than 1 degree for highway use. Package includes two each of 1°, 2° and 3° shims (six shims total).

- P4529536** Axle Shim Package, Rear, 8-1/4"/ 8-3/4" Dana 60 Axles
- P5153561** Axle Shim, Rear, 1°, 2pcs.
- P5153562** Axle Shim, Rear, 2°, 2pcs.
- P5153563** Axle Shim, Rear, 3°, 2pcs.



E.

# STEERING, SUSPENSION & BRAKES 10



P  
R  
I  
N  
T  
I  
N  
G  
S

27-11-1996 10:29

1002

R-2280

## STEERING, SUSPENSION, AND BRAKES

### LEAF SPRINGS AND HARDWARE

#### A. XHD Leaf Springs - Original Equipment

These extra heavy-duty O.E. Leaf Springs are just like the bias design production springs that were stock on 1968-72 A-Body vehicles with 340 high-performance engines, 1967-71 B-Body vehicles with 440 or 426 manual and automatic transmissions, and 1970-74 E-Body vehicles with 440 or 426 manual or automatic transmissions. Springs will fit any A-Body (1968-72), B-Body (1966-72) or E-Body (1970-74), regardless of engine size, and come with front bushings installed in assembly. B-Body: front 22", rear 36". Select right or left spring.

- P4510269** Leaf Spring, Left, O. E., 1964-75 A-Body
- P4452983** Leaf Spring, Left, O. E., 1966-72 B-Body
- P4452985** Leaf Spring, Left, O. E., 1970-74 E-Body
- P4510268** Leaf Spring, Right, O. E., 1964-75 A-Body
- P4452982** Leaf Spring, Right, O. E., 1966-72 B-Body
- P4452984** Leaf Spring, Right, O. E., 1970-74 E-Body



#### B. Competition Leaf Springs - Super Stock

Designed to control torque roll, providing equal bite on rear wheels through limited axle windup. These springs don't lock up the rear, but allow it to move, keeping the tires on the track where they belong. The rear springs listed below have a 20-inch front segment and require a longer front spring hanger bracket for B-, E-, F-, J- and M-Bodies (not included). Standard hanger brackets used on A-Body. When P3412002/03 is used on a "B" or "E" body frame, the rear spring eye in the frame must be relocated forward; Pinion Snubber is recommended. If using P4120863, vehicle will not be level at standstill.

- <sup>1</sup> **P4120864** Leaf Spring, Competition, Left, 2,800 lbs. (A-Body)
- <sup>1</sup> **P3412003** Leaf Spring, Competition, Left, 3,000-3,200 lbs., Modified, Hemi Super Stock A-Body, B-Body with Relocated Shackle
- <sup>1</sup> **P4120866** Leaf Spring, Competition, Left, 3,300 lbs., E-Body Barracuda-Challenger, B-Body w/Shackle Relocation
- <sup>1</sup> **P3690457** Leaf Spring, Competition, Left, 3,400 lbs., 1964-65 Super Stock B-Body
- <sup>1</sup> **P3690461** Leaf Spring, Competition, Left, 3,600 lbs., E-Body Barracuda-Challenger, B-Body w/Shackle Relocation
- <sup>1</sup> **P3690455** Leaf Spring, Competition, Left, 3,800 lbs., B-Body
- <sup>1</sup> **P4120863** Leaf Spring, Competition, Right, 2,800 lbs., A-Body
- <sup>1</sup> **P3412002** Leaf Spring, Competition, Right, 3,000-3,200 lbs., Modified Cars, 1968 Hemi Super Stock A-Body
- <sup>1</sup> **P4120865** Leaf Spring, Competition, Right, 3,300 lbs., E-Body Barracuda-Challenger, B-Body w/Shackle Relocation
- <sup>1</sup> **P3690456** Leaf Spring, Competition, Right, 3,400 lbs., 1964-65 Super Stock B-Body
- <sup>1</sup> **P3690460** Leaf Spring, Competition, Right, 3,600 lbs., E-Body Barracuda-Challenger, B-Body w/Shackle Relocation
- <sup>1</sup> **P3690454** Leaf Spring, Competition, Right, 3,800 lbs., B-Body

A.



B.

#### C. Oval Track Leaf Springs

Reissued Mopar Kit Car Leaf Springs are ideal for oval track applications. These springs are widely used on dirt track race cars. The spring rate is 120 lbs. per inch. Front 20.5", Rear 35.0".

- <sup>1</sup> **P4529415** Leaf Spring, Oval track, 1" Arch
- <sup>1</sup> **P4529414** Leaf Spring, Oval Track, No Arch



C.

LEAF SPRINGS AND HARDWARE

A. Solid Leaf Spring Front Eye Bushings

Contains two 1-1/2-inch aluminum Spring Eye Bushings with steel sleeves. Improves spring reaction by cutting down on rubber deflection. Steel sleeve allows free movement of aluminum bushing. Designed for use with competition leaf springs (Super Stock).

**P4510644** Bushing, Leaf Spring, Front Eye, Aluminum, Solid, 1-1/2" Diameter., 3.125" Length, A-/B-/E-Bodies

B. Rear Spring Shackle Bushings

For A-, B- or E-Body vehicles. Available in high-performance polyurethane for improved vehicle handling, or factory original equipment heavy-duty rubber for restoration projects. Sold in sets of eight bushings.

**P4510643** Shackle Bushings, Rear Spring, Polyurethane, A-Body

**P4452987** Shackle Bushings, Rear Spring, Rubber, O. E., 1", B-/E-Body, Super Stock Springs

**P4452986** Shackle Bushings, Rear Spring, Rubber, O. E., 7/8" A-Body

C. Rear Spring Clamp Package

Clamps to the front half of rear leaf springs to increase stiffness so you can fine-tune the rear suspension for optimal traction. Contains clamps for two springs.

**P4120470** Clamp Package, Rear Springs.

D. Rear Spring Front Hanger Bracket Sets

These straight hangers are 2.0" longer for use with Super Stock springs.

<sup>1</sup> **P4120080** Hanger Bracket, Front, 108"/110"/115" Wheelbase, 1964-65 Mod. B-Body, 1970-74 E-Body, 1971-74 B-Body HT, Set

<sup>1</sup> **P4120081** Hanger Bracket, Front, 110" Wheelbase, 1976-80 F-Body, 1980-83 J-Body, 1977-78 M-Body, Set

<sup>1</sup> **P4120105** Hanger Bracket, Front, 116" Wheelbase, 1966-70 Plymouth B-Body Sedans, 1971-74 B-Body Wagons, Set

<sup>1</sup> **P4120079** Hanger Bracket, Front, 117" Wheelbase, 1966-70 Dodge B-Body Sedan and Wagon, Set

E. Offset Rear Spring Front Hanger Bracket Sets

Moves the springs in next to the frame. Requires spring seat and offset shackles to be moved. Offers the maximum possible movement inboard for tire clearance without frame rework.

**P4120077** Hanger Bracket, Rear Spring, Front, Offset, A-Body

**P4120078** Hanger Bracket, Rear Spring, Front, Offset, E-Body with Super Stock Springs



A.



B.



C.



D.

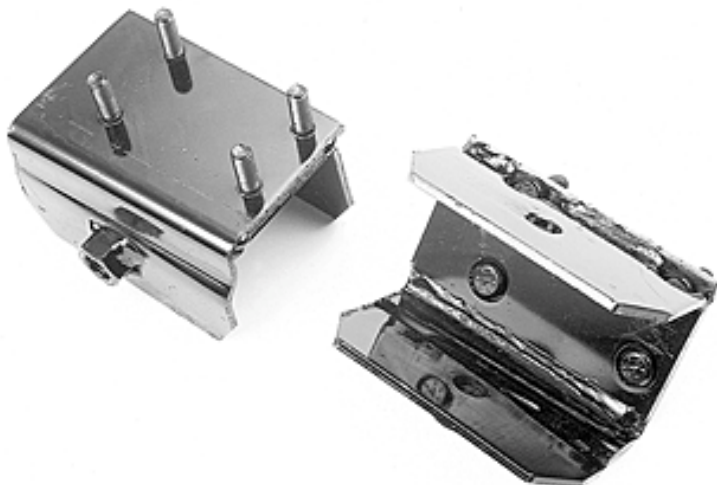

E.

Questions? Call the Mopar Direct Connection Techline at 1-888-528-HEMI (4364)

<sup>1</sup> Not legal on pollution-controlled vehicles or vehicles registered for highway use.

## STEERING, SUSPENSION, AND BRAKES

### LEAF SPRINGS AND HARDWARE

#### A. Rear Spring Mounting Seats

When installing a leaf spring suspension, use these Rear Spring Mounting Seats. These seats work with all 3-inch diameter tube rear axles (8 1/4", 8 3/4", 9 1/4", 9 3/4")

- P5007857** Mounting Seats, Rear Spring, 0.520" Centerline. Fits all Mopar Performance Leaf Springs
- P4120074** Mounting Seats, Rear Spring, 0.670" Centerline

#### B. Rear Spring Shock Mounting Plates

Designed for A-, B- and E-Body cars. Provides lower shock pivot, plus support for the U-bolts that hold the rear spring to the axle. Sold individually. Shock stud is not included.

- P4876519** Shock Mounting Plates, Rear Spring, Left, A/B/E-Bodies

#### C. Spring Relocation Kits

Moves leaf springs in 3" per side for added tire clearance. Kits mount longitudinally. Requires welding. Includes front hangers, shackles, rear shackle mounts and spring mounting seats. A-body uses small rear spring eye.

- P4876558AB** Spring Relocation Kit, A-Body
- P4120665AB** Spring Relocation Kit, B/E-Body

#### D. Spring U-Bolt and Nut Packages

For replacement of U-bolts when working on your vehicle's springs. Packages include four spring/axle U-bolts and eight nuts.

- P5249709** Spring U-Bolt and Nut Package, 7", 8 3/4" and Dana 60 Axles
- P4120611** Spring U-Bolt and Nut Package, 8"
- P4120612** Spring U-Bolt and Nut Package, 9"

#### E. Straight Rear Shackle Packages

Packages come with bushings, side plates and nuts. Can be used for general service and special applications, such as spring relocation kits.

- P5249715** Shackle Bushing Rear, Straight, A-Body, One Shackle Only
- P5249716** Shackle Bushing Rear, Straight, B-Body, One Shackle Only

#### F. Offset Rear Shackle Packages

Offset is approximately 0.80" for use on cars with relocated rear springs. Use with offset front hangers.

- P4120075** Shackle Bushing, Rear, Offset, A-Body
- P4120076** Shackle Bushing, Rear, Offset, B/E-Body



A.

B.



C.

D.



E.

F.

FRAME COMPONENTS

A. Bolt-In Frame Connector Packages

These prefabricated Bolt-In Frame Connector Packages let you tie the front and rear frame longitudinally on all A-, B- or E-body drag cars. They can be welded for additional strength and rigidity. Packages include two connectors, brackets and necessary mounting hardware.

- P4286868 Frame Connector, Bolt-In, 108" Wheelbase, 1967-76 A-Body
- P4286870 Frame Connector, Bolt-In, 108"-110" Wheelbase, 1970-74 E-Body
- P4876658 Frame Connector, Bolt-In, 111" Wheelbase, 1967-76 A-Body
- P4286869 Frame Connector, Bolt-In, 115"-117" Wheelbase, 1966-72.5 B-Body

B. Adjustable Pinion Snubbers

Helps control axle windup by adjusting the height to the floor pan. Units fit to the center front of the rear axle housing.

- P3690182 Pinion Snubber, Adjustable, 8-3/4" Axles
- P3690181 Pinion Snubber, Adjustable, Dana 60 Axles

TORSION BARS AND HARDWARE

C. Torsion Bar Sets

Mopar offers torsion bars for A-Body and 1962-1972 B and E Body vehicles in a variety of diameters for restoration, performance and racing. Improve the suspension performance and cornering ability or weight transfer of your vehicle with these Mopar Torsion Bar Sets. The A-Body bars are 35.70" long; the B and E-Body bars are 41" long. These sets bolt right into stock locations without modifications (sold in sets of two). A and E-Body bars fit all years. B-Body bars fit 1962-1972 only.

- P5249148 Torsion Bar, 0.810" Diameter, A-Body, Set
- P5249150 Torsion Bar, 0.890" Diameter, A-Body, Set
- P5249151 Torsion Bar, 0.920" Diameter, A-Body, Set
- P5249157 Torsion Bar, 0.920" Diameter, B/E-Body, Set
- P5249158 Torsion Bar, 0.960" Diameter, B/E-Body, Set

D. Torsion Bar Lock and Seal

- P5249609 Lock and Seal, Torsion Bar, A Body/ 1962-72 B/E-Bodies
- P4876097 Lock Clip, Torsion Bar, A/B/E-Bodies

SUSPENSION SEALS AND BUSHINGS

E. Front End Seal Packages

Contains seals for tie rod ends, pitman arm, upper and lower, ball joints and idler arm.

- P5249229 Seal Package, Front, 1968-72 B-Body



A.



B.



C.



D.



E.

## STEERING, SUSPENSION, AND BRAKES

### SUSPENSION SEALS AND BUSHINGS

#### A. Front Strut Bushing Packages

Used to minimize fore and aft movement during braking and hard acceleration. Made of special high-durometer material.

- <sup>1</sup> P4529183 Bushing Package, Front Strut, 1967-76 A-Body, 2-pcs.
- <sup>1</sup> P4529184 Bushing Package, Front Strut, B/E-Body, 4-pcs.

#### B. Replacement End-Link Bushings

These hard, urethane End-Link Bushings can be used to replace your stock bushing or with Mopar Sway Bars. Extra hard for positive stiffness and longer wearability. Sold as a set of eight.

- <sup>1</sup> P4349116 Bushings, End Link, Replacement

### MANUAL STEERING HARDWARE

#### C. Manual Steering Gear Worm and Ball Nut Package

Replace your 26:1 manual steering production gear ratio set with this improved 20:1 ratio Manual Steering Gear Worm and Ball Nut Package.

- <sup>1</sup> P4007612 Gear Worm and Ball Nut Package, Manual Steering, 1963-85 Passenger Cars

#### D. Power to Manual Steering Adapter

This adapter allows you to convert vehicles equipped with power steering to a manual steering box.

- <sup>1</sup> P4510637 Manual Steering Adapter, A/B/E-Bodies

### SHOCKS AND STRUTS

#### E. Drag Race Rear Shock Absorbers

Designed with the extended length required by special drag racing applications. Sold individually.

- <sup>1</sup> P4529514 Shock Absorber, Rear, Drag Race, Automatic Transmission, A-Body
- <sup>1</sup> P4529515 Shock Absorber, Rear, Drag Race, Automatic Transmission, B/E-Body

### BRAKES

#### F. Master Cylinder Heat Shield

Prevents heat from exhaust header or exhaust manifolds from boiling and degrading brake fluid. Perfect for Big Block, A-Body conversions.

- <sup>1</sup> P4510634 Heat Shield, Master Cylinder, Stainless, Big Block, A-Body

#### G. Master Cylinder Adapter

Converts from four-stud to two-stud attaching style. For use with Mopar Brake Cylinder Pushrod Package (P5249316AB).

- <sup>1</sup> P5249315 Master Cylinder Adapter



A.



B.



C.



D.



E.



F.

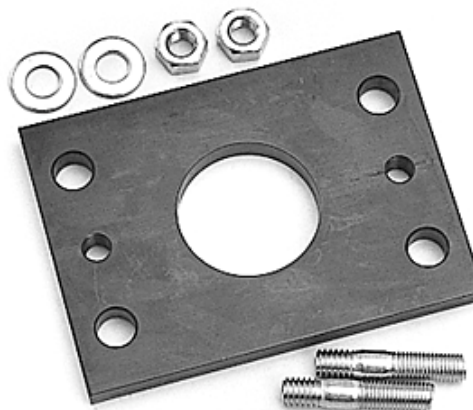

G.



**BRAKES**

**A. Master Cylinder Offset Adapter**

Moves the master cylinder away from the engine for added clearance with Hemi or 440 engine valve covers. Designed specifically for 1968 Hemi A-Body cars. Can also be used for other A-body applications when installed on 426 Hemi engines.

<sup>1</sup> P5249717 Master Cylinder Adapter, Offset, 1968 Hemi A-Body

**B. Brake Pushrod, Adjustable**

For use with Mopar lightweight Master Cylinder Assemblies (P5249270 and P5249271 which are currently discontinued).

<sup>1</sup> P4510640 Pushrod, Brake, Adjustable

**C. Brake Proportioning Valves**

Made from lightweight billet aluminum. Compact for all applications. Perfect for all hydraulic brake applications and is easily adjusted with the turn of a knob. For diagonally-split brakes, install one valve in each rear brake line (does not change brake system to front-to-rear split).

<sup>1</sup> P5249088 Brake Proportioning Valve, Lightweight



A.



B.



C.

Questions? Call the Mopar Direct Connection Techline at 1-888-528-HEMI (4364)

<sup>1</sup> Not legal on pollution-controlled vehicles or vehicles registered for highway use.





PERFORMER

27-11-196-1129

## INTERIOR/BODY

### UNDERHOOD

#### A. Air Cleaner Lids

77R06094 Air Cleaner Lid, Used On Air Grabber Hoods, 1970 Road Runner/GTX

#### B. Decals, Air Cleaner Lid

Mopar offers replacement Decals for doors, hoods, and decklids to perfectly match the style you need. If your decals are damaged or badly faded, replace them with these brand-new pieces.

77R06184 340 SIX BARREL Decal, Air Cleaner Lid

77R06185 340 SIX PACK Decal, Air Cleaner Lid

77R06183 426 HEMI Decal, Air Cleaner Lid

77R06182 440 MAGNUM SIXPACK Decal, Air Cleaner Lid

#### C. Decals, Air Cleaner Element Service

Mopar offers replacement Decals for doors, hoods, and decklids to perfectly match the style you need. If your decals are damaged or badly faded, replace them with these brand-new pieces.

77R06170 Service Decal, Air Cleaner Element, 1968-71 340 4bbl., 383 4bbl., and 440 4bbl. w/o Air Induction

77R06173 Service Decal, Air Cleaner Element, 1969 1/2, Set of 2

77R06171 Service Decal, Air Cleaner Element, 1969-71 All vehicles w/Multi-Carburetion Air Induction -Type Hoods, All AAR and T/A cars.

77R06172 Service Decal, Air Cleaner Element, 1970 AAR and T/A applications

#### D. Decals, Radiator Service

Mopar offers replacement Decals for doors, hoods, and decklids to perfectly match the style you need. If your decals are damaged or badly faded, replace them with these brand-new pieces.

77R06175 Radiator Service/Warning Decal, Chrysler



A.



B. 77R06184



B. 77R06185



B. 77R06183



B. 77R06182



B. 77R06181



C. 77R06170



C. 77R06173



C. 77R06171



C. 77R06172



D. 77R06175



D. 77R06174



A. 02889803



A. 03431074



A. 03431590



B.



C.



D. P1828352



D. 03404404



E. 77R06151



E. 77R06152

## UNDERHOOD

### A. Windshield Washer Reservoir

When judges look under the hood, a sparkling clean Windshield Washer Reservoir really stands out. If yours is yellow or cracked, don't clean it. Instead, replace it with a brand-new one from Mopar. Exact reproduction; uses production hardware.

- P2889803 Windshield Washer Reservoir, 1967-70 B-Body
- P2809011 Windshield Washer Reservoir, 1967-82
- P2497502 Windshield Washer Reservoir, 1968-69 A-Body w/2-Speed Wipers, Restoration
- 03431074 Windshield Washer Reservoir, 1970-71 E-Body/ 1971 B-Body
- P3431154 Windshield Washer Reservoir, 1970-73 C-Body
- 02983067 Windshield Washer Reservoir, 1970-75 A-Body/Duster/Dart/Demon/Swinger/Valiant
- P3431590 Windshield Washer Reservoir, 1972-74 B/E-Body

### B. Battery Tray, Restoration

Replace that rusty or missing battery tray with a new Mopar restoration unit. Manufactured to exact specifications, this tray comes e-coated to protect it from chemical and moisture exposure. This tray fits all 1970-74 E-Body and 1971-74 B-Body applications.

- P2925322 Battery Tray, 1970-74 E-Body/ 1971-74 B-Body, Restoration

### C. Battery Hold-Down Hardware

Your Battery Hold-Down Hardware is old and rusty. You could try and paint it, but that would subtract valuable judging points at the local show 'n shine. Mopar now carries brand-new original equipment-style hardware, so you don't have to spend time searching when you can be enjoying more time behind the wheel.

- P3151736 Battery Hold-Down Nut, Fits all 1962-1974 A/B/E-Body Applications
- 02534814 Battery Hold-Down Stud, Long, Outer

### D. Battery Hold-Down Strap

- P1828352 Battery Hold-Down Strap, 1963-69 A-Body, 1964-69 B-Body, 1968-73 C-Body
- 03404404 Battery Hold-Down Strap, 1970-76 A-Body, 1970-73 B-Body, 1970-74 E-Body

### E. Pulleys- Crankshaft

- 77R06166 Pulley, Crank, w/AC, Four Groove, B/RB/Hemi Crate, Black
- 77R06151 Pulley, Crank, w/o AC, Double Groove, A-Eng. (70 up), B/RB/Hemi and all Magnum and Commando Crate Engines
- 77R06155 Pulley, Crank, w/o AC, Double Groove, A-Eng. (70 up), B/RB/Hemi and all Magnum and Commando Crate Engines, Chrome
- 77R06152 Pulley, Crank, w/o AC, Single Groove, A/B/RB/Hemi and Magnum Crate Engines
- 77R06156 Pulley, Crank, w/o AC, w/o P.S., Single Groove, A-Eng (70 up) B/RB/Crate Hemi, Chrome

## INTERIOR/BODY

### UNDERHOOD

#### A. Pulleys- Power Steering

- 77R06163 Pulley, Power Steering, w/Nutted Key Shaft, Saginaw Style, 1966-75 B/RB/HEMI Crate Engines, Black
- 77R06164 Pulley, Power Steering, w/Nutted Key Shaft, Saginaw Style, 1966-75 B/RB/HEMI Crate Engines, Chrome
- 77R06165 Pulley, Power Steering, w/Press Fit Shaft, Saginaw Style, B/RB/HEMI Crate Engines

#### B. Pulleys- Water Pump

- 77R06153 Pulley, Water Pump, w/o AC, A-Eng., Commando and Magnum Crate Engines
- 77R06158 Pulley, Water Pump, w/o AC, A-Eng., Commando and Magnum Crate Engines, Chrome
- 77R06154 Pulley, Water Pump, w/o AC, B/RB/Crate HEMI
- 77R06150 Pulley, Water Pump, w/o AC, B/RB/HEMI Applications, Black
- 77R06157 Pulley, Water Pump, w/o AC, B/RB/HEMI Applications, Chrome

#### C. Mounting Brackets

- 77R06162 Bracket, Power Steering, Saginaw Style, B/RB/HEMI Applications
- 77R06159 Bracket, Alternator, w/A/C., B/RB Engines
- 77R06160 Bracket, Alternator, w/o A/C., B/RB Hemi Engines
- 77R06168 Bracket, Engine Mounting, LH, B/RB, 1972-93 Dodge Pick-Up, 4X2 & 4X4 Models
- 77R06167 Bracket, Engine Mounting, RH, B/RB, 1972-93 Dodge Pick-Up, 4X2 & 4X4 Models

#### D. Oil Filter- Restoration

Mopar has reissued these service replacement oil filters, used in the 1960s and 1970s. The white filter was used from the 1960's throughout the 70's. The high-performance white filter (P4529805) was recommended for use in competition from 1965 to 1974. The black filter was used from the late 1950's through the early 60's. These filters may not fit some V8 applications (those after 1972 requiring short filters).

- 77R06287 Oil Filter, Factory Assembly Line Style, 1966-71 V8 and Six Cylinder Applications, Restoration
- P4529806 Oil Filter, Restoration, Black with Yellow Mopar logo, 1962-66 V8
- P4529805 Oil Filter, Restoration, High-Performance, White with Red Stripe

#### E. PCV Valves

- 77R06293 PCV Valve, No Ribs, 1970-74 318/ 340/ 360
- 77R06294 PCV Valve, Steel, 90 degrees, All 1963-69 V8 Applications
- 77R06292 PCV Valve, Three-Ribbed, 1970-71 B/RB/HEMI



A. 77R06163



B. 77R06153



C.



D. P4529805



D.



D. 77R06287



E.



A.



B.



C. P2806186



C. P2863257



C. P3462193



C. P3462113



C. P3462184



C. P3462116



D. P2658931



D. P2863245



D. P2863256

UNDERHOOD

A. Engine Paint

Mopar enamel engine paint is matched to OEM colors to keep your engine compartment looking original. 16-ounce cans.

- P4120753AB Engine Paint, Black, 1981-93 2.2L and 1983-00 318/360 Small Block
- P4349217AB Engine Paint, Blue, All 1972-83 Engines, Except 2.2L and 1964-69 318
- P4529149 Engine Paint, Gold
- P4120751AB Engine Paint, Hemi Orange, 1964- 65 Race Hemi, 1962- 64 Max Wedge
- P4349218AB Engine Paint, Red, 1964- 69 273/ 1968- 69 340/ 1964- 69 360 Small Block
- P4529148 Engine Paint, Silver
- P4349216AB Engine Paint, Street Hemi Orange, 1966-71 Hemi, 1970-71 HP 340/383/440
- P4120752AB Engine Paint, Turquoise, 1962- 71 Big Block except High Performance, 1969- 71 383/440 Big Block

B. 340 Exhaust Manifold Heat Shield

This heat shield fits all 1968-70 340 engines with the HP-style driver's side exhaust manifold and it protects the spark plug wire boot from contacting the manifold.

- P2946105 Heat Shield, Exhaust Manifold, Driver's Side, 340

C. Radiator Hose- Upper

- P2806186 Radiator Hose, Upper, 1967-71 B-Body, w/383-4, 440-4, 440-6 & 426 Hemi, w/26" Radiator
- P2863201 Radiator Hose, Upper, 1968 B-Body, B/RB, with 22" Radiator
- P2863244 Radiator Hose, Upper, 1969 B-Body, w/383, 440-4, w/26" Radiator
- P2863230 Radiator Hose, Upper, 1969 B-Body, w/426 Hemi only
- P2863257 Radiator Hose, Upper, 1969-71 B/E-Body, w/383, 440, w/26" Radiator
- P3462193 Radiator Hose, Upper, 1970 AAR 'Cuda, T/A Challenger, w/340 Six Pack only
- P3462114 Radiator Hose, Upper, 1970-71 B-Body, w/440-6 and 1970-71 B/E-Body w/383, 22" Radiator
- P3462113 Radiator Hose, Upper, 1970-71 E-Body, w/426 Hemi and Shaker Hood
- P3462184 Radiator Hose, Upper, 1970-71 E-Body, w/426 Hemi and Shaker Hood
- P3462116 Radiator Hose, Upper, 1970-71 E-Body, w/440-6 & 440-4, w/22" Radiator

D. Radiator Hoses- Lower

- P3462165 Radiator Hose, Lower, 318/ 340, 1970-71 A/B/E-Body
- P2658931 Radiator Hose, Lower, 383/ 440, 1967-68 B-Body
- P2863245 Radiator Hose, Lower, 383/ 440-4/ 440-6, 1969 B-Body
- P2863256 Radiator Hose, Lower, 383/ 440-4/ 440-6/ 426 Hemi, 1970 B/E-Body
- P3462119 Radiator Hose, Lower, 440-4/ 440-6/ 426 Hemi, 1971 B/E-Body

Questions? Call the Mopar Direct Connection Techline at 1-888-528-HEMI (4364)

<sup>1</sup> Not legal on pollution-controlled vehicles or vehicles registered for highway use.

## INTERIOR/BODY

### UNDERHOOD

#### A. Heater Hose

77R06297	Heater Hose, w/AC, 1967 A/B-Body, All V8 Applications
77R06299	Heater Hose, w/AC, 1968 A/B-Body, All V8 Applications
77R06301	Heater Hose, w/AC, 1969 A/B-Body, All V8 Applications
77R06307	Heater Hose, w/AC, 1970 A/E-Body, All V8 Applications
77R06303	Heater Hose, w/AC, 1970 B-Body, All V8 Applications
77R06305	Heater Hose, w/AC, 1971 B-Body, All V8 Applications
77R06311	Heater Hose, w/AC, 1971 E-Body, All V8 Applications
77R06309	Heater Hose, w/AC, 1972 A/B/E-Body, All V8 Applications
77R06296	Heater Hose, w/o AC, 1967 A/B-Body, All V8 Applications
77R06298	Heater Hose, w/o AC, 1968 A/B-Body, All V8 Applications
77R06300	Heater Hose, w/o AC, 1969 A/B-Body, All V8 Applications
77R06306	Heater Hose, w/o AC, 1970 A/E-Body, All V8 Applications
77R06302	Heater Hose, w/o AC, 1970 B-Body, All V8 Applications
77R06304	Heater Hose, w/o AC, 1971 B-Body, All V8 Applications
77R06310	Heater Hose, w/o AC, 1971 E-Body, All V8 Applications
77R06308	Heater Hose, w/o AC, 1972 A/B/E-Body, All V8 Applications



A.

#### B. Radiator Cap

When you open the hood, it's right there where everyone can see it -- especially the judges. If your radiator cap is more than ten years old or just looks bad, replace it with this original equipment-quality piece.

77R06021	Radiator Cap, 16 lb. (22" and 26" Radiator)
----------	---



B.

#### C. Radiator Cooling Fan Shrouds- 26.00"

P2785434	Fan Shroud, Radiator, 1967-69 426 Hemi, 383/440 Big Block B-Body, Five-Stud Mounting, Restoration
P2998326	Fan Shroud, Radiator, 1970-73 426 Hemi, 383/440 Big Block B/E-Bodies, Four-Screw Mounting Shown, Restoration



C.

#### D. Exhaust Tips

77R06139	Exhaust Tips, 1970-74 'Cuda, 2-1/2" Stainless, Pair
77R06135	Exhaust Tips, Long, 1971-74 B-Body, 2-1/2" Black, Chrome Slotted, Pair
77R06136	Exhaust Tips, Short, 1971-74 B-Body, 2-1/2" Red, Chrome Slotted, Pair



D. 77R06135





A. 77R06039



A. 77R06040



A. 77R06043



A. 77R06042



A. 77R06045



B. 77R06056



C. 77R06082



D. 77R06061



E. 77R06291



F. 77R06126



F. 77R06127



G. 77R06289

INTERIOR

A. Dash Bezels

- 77R06046 Dash Bezel Housing, 3 & 4 Switch Side Pod, Rallye, 1970-74 E-Body, Black
- 77R06045 Dash Bezel Housing, Rallye, 1970-74 E-Body, Black
- 77R06039 Dash Bezel Kit, Black, 5 Pieces, 1968 B-Body
- 77R06040 Dash Bezel Kit, Black, 5 Pieces, 1969 B-Body
- 77R06043 Dash Bezel Kit, Black, 5 Pieces, 1970 B-Body
- 77R06041 Dash Bezel Kit, Woodgrain, 5 Pieces, 1969 B-Body
- 77R06042 Dash Bezel Kit, Woodgrain, 5 Pieces, 1970 B-Body

B. Gauge Components

- 77R06056 Cable, Clock Reset, Bezel Not Included

C. Gauge Lense

- 77R06083 Gauge Indicator Lenses, Rallye, 1970-74 E-Body, (Sold In a Set of 3)
- 77R06082 Gauge Lense, Clear, Rallye, 1970-71 E-Body
- 77R06084 Gauge Lenses, Clear, Rallye, 1970-74 E-Body, (Sold In a Set of 3)

See the "Performance Gauges" section in this catalog for additional gauge options.

D. Switches

- 77R06057 3- Switch, Woodgrain, Rallye, With Fascia and Mounting Bracket, 1970-71 E-Body
- 77R06060 3- Switch, Woodgrain, Rallye, With Fascia and Mounting Bracket, 1972-74 E-Body
- 77R06059 4- Switch, Woodgrain, Rallye, Top Lift with Fascia and Mounting Bracket, 1970-71 E-Body
- 77R06061 4- Switch, Woodgrain, Rallye, With Rear Defrost, Fascia and Mounting Bracket, 1972-74 E-Body

E. Console

- 77R06291 Console, Automatic, Black, 1967-70 B/C-Body
- 77R06290 Console, Four Speed, Black, 1967-70 B/C-Body

F. Console/Shifter Plate

- 77R06124 Console Plate, 4-Speed, 1968 B-Body
- 77R06126 Console Plate, 4-Speed, Woodgrain, 1969-70 B-Body
- 77R06127 Shifter Plate, Automatic, Chrome, 1970-74 B/E-Body
- 77R06002 Bolt Package, Shifter Plate, Self-Locking

G. Shift Knob

- 77R06289 Shifter, Automatic, Includes Knob, Shifter Button, and Spring, 1969-70 B-Body, 1970 E-Body, 1969-74 A-Body

Questions? Call the Mopar Direct Connection Techline at 1-888-528-HEMI (4364)

<sup>1</sup> Not legal on pollution-controlled vehicles or vehicles registered for highway use.

## INTERIOR/BODY

### INTERIOR

#### A. Shifter Boot

If your shifter boot is damaged, worn or missing, we've got you covered. This quality reproduction looks great and uses the same materials as the original production unit.

- 03467764** Shifter Boot, 1967-76 Dart/Demon/Duster
- P3467766** Shifter Boot, 1970-74 'Cuda/Challenger, 1971-74 Road Runner/GTX and Charger
- 77R06051** Shifter Boot, 4-Speed Rubber, 1966-70 B-Body

#### B. Steering Wheel

If your steering wheel is cracked, faded or badly damaged, replace it with this high-quality reproduction. Helps your interior look like new.

- P5153385** Steering Wheel, Black, 1968-69 Charger/ Coronet/ Dart/ Road Runner/ GTX/ Barracuda

#### C. Turn Signal Switch Assembly

Why pay good money at a swap meet for an old, used turn signal switch assembly when Mopar offers brand-new units for the same price? This high-quality assembly is an exact reproduction. It installs easily with no modifications necessary.

- 04293102** Turn Signal Switch, Assembly, 1970-76 A/B/E-Bodies

#### D. Arm Rests

- 77R06036** Armrest, B-Body, Front, 13", Pair
- 77R06037** Armrest, B-Body, Front, 16 1/4", Pair
- 77R06038** Armrest, B-Body, Rear, 9", Pair



A. P3467766



A. 77R06051



B. P5153385



C.



D. 77R06036



D. 77R06037



D. 77R06038

 <p>A. 77R06068</p>	 <p>A. 77R06071</p>
 <p>A. 77R06069</p>	 <p>A. 77R06101</p>
 <p>A. 77R06070</p>	 <p>A. 77R06284</p>
 <p>B. 03416002</p>	 <p>C.</p>
 <p>D. P5153381</p>	 <p>E. Does not include headlamp bezels</p>

## INTERIOR

### A. Interior Handles/ Levers

- 77R06068 Handle, Door, Interior, 1968-70 B-Body, Sold as a Pair
- 77R06069 Handle, Door, Interior, 1971-74 B-Body, Sold as a Pair
- 77R06071 Handle, Door, Interior, Challenger, Sold as a Pair
- 77R06072 Handle, Door, Interior, 'Cuda, Sold as a Pair
- P2947953 Lever, Turn Signal, 1970-74 Dodge Challenger and Plymouth Barracuda/Cuda Applications
- 77R06284 Lever, Turn Signal, A/B/E-Bodies
- 77R06101 Lock, Door, Interior, E-Body, Sold as a Pair

### B. Rocker Sill Plate

Unless your classic has been hermetically sealed since it was new, your rocker sill plates are probably heavily scratched and/or damaged. These quality pieces are precise reproductions that will help make your ride look factory fresh.

- 03416002 Sill Plate, Rocker, 1971-74 B-Body 2-Door, Sold Individually
- P2879600 Sill Plate, Rocker, 1970-74 Challenger/ Barracuda, Sold Individually

### C. Floor Mats, Paper

- 77R06178 Floor Mat, Paper, Dodge, "Customer Care"
- 77R06177 Floor Mat, Paper, Plymouth, "Customer Care"

### D. Floor Mats, Rubber

These high-quality Rubber Floor Mats are exact reproductions of the factory units. They'll add an authentic look to any classic Mopar.

- P5153381 Floor Mats, Rubber, Black with Mopar Logo
- P5153382 Floor Mats, Rubber, Blue with Mopar Logo
- P5153383 Floor Mats, Rubber, Dark Green with Mopar Logo

## GRILLES AND HEADLAMP BEZELS

### E. Road Runner Grille

Who offers brand-new grilles manufactured to original equipment specifications? Mopar, of course! Add this beautiful reproduction to your ride and be the envy of all. No modifications necessary.

- P5153427 Grille, 1969 Road Runner
- P5153416 Grille, with Headlamp Bezels, 1969 Road Runner

## INTERIOR/BODY

### GRILLES AND HEADLAMP BEZELS

#### A. Grille and Headlamp Bezel Package

Now you can replace the grille and headlight bezels for your classic without having to break the bank. This complete package will make your ride stand apart from the crowd. High-quality reproduction pieces are made to original equipment specifications.

- P5153416 Grille, with Headlamp Bezels, 1969 Road Runner
- 77R06067 Grille, with Headlamp Bezels, Rectangular, Chrome, 1971 'Cuda AAR/Grand Coupe, Sold as a set (Mounting Clips not Included)
- 77R06149 Grille, with Headlight Bezels, 1970 Plymouth Barracuda

#### B. 'Cuda Lower Front Grille

If the lower front grille on your muscle car is badly scratched, distorted or cracked, replace it with this brand-new piece from Mopar. This high-quality reproduction fits perfectly and includes the turn signal light casings. It is durable and paintable. Get one now at a price that can't be beat.

- 03672933 Grille, Front, Lower, 1972-74 'Cuda

#### C. Headlamp Bezels

Headlight Bezels need replacing but you don't have time to search for individual matching pieces? No problem! Mopar offers this high-quality reproduction set for all owners who demand the very best. No modifications necessary.

- P5153417 Bezels, Headlamp, 1969 Road Runner, Set
- 77R06049 Bezels, Headlamp, 1971 'Cuda, Black, Unfinished
- 77R06050 Bezels, Headlamp, 1971 'Cuda, Chrome, Set of 4
- 77R06130 Bezels, Headlamp, 1972-74 Challenger, Set of 4

#### D. Headlamp Brackets

- 77R06054 Brackets, Headlight, 1971 'Cuda, Brackets that mount to the headlight bucket for the 4 light setup including mounting feet, Pair
- 77R06053 Brackets, Road Lamp, 1970 'Cuda, Pair
- 77R06055 Brackets, Road Lamp, 1971 'Cuda, Pair

#### Splash Shield (Not Shown)

- 77R06131 Splash Shield, Inner Headlight, 1970-74 'Cuda, Except 1971, Pair
- 77R06134 Splash Shield, Inner Headlight, 1971 'Cuda, Pair

### HOODS AND HOOD COMPONENTS

#### E. Hood Pin and Cable Kit

Kit includes a pair of Hood Pins and all attachment hardware. Exposed hardware is chrome-plated.

- P4529405 Hood Pin Kit
- 77R06123 Hood Pin Kit, B/E-Body, 23" Lanyard



A. P5153416



A. 77R06149



B. 03672933



C. P5153417



C. 77R06049



D. 77R06054



D. 77R06053



E.

HOODS AND HOOD COMPONENTS

A. Dodge Challenger Hood

This high-quality steel hood is an exact reproduction that will make your Challenger look like it just came from the factory. Forget welding, grinding, filling and sanding--who needs it? But if you want to brag about the long hours you spent to make it look perfect, go right ahead--we won't tell!

**P5153393** Hood, Rallye, Dual Scoop Type, 1970-74 Challenger R/T and Rallye

B. Shaker Hood Seal

A whole lotta shakin' means a lot of wear and tear to your hood seal. If your Shaker Hood Seal hasn't been replaced within the last ten years, odds are you're overdue. This reproduction offers a perfect fit and the same high quality as the original.

**03418658AB** Hood Seal, Shaker, 1970 - 71 'Cuda and Challenger Shaker Hood

C. Actuator Bracket

**77R06052** Actuator Bracket, Air Grabber, 1970-72 Road Runner/Charger

D. Air Grabber Flapper

**77R06062** Air Grabber Flapper, 1970-72 Roadrunner/Charger

HANDLES

E. Exterior Door Handles

**03739844** Gasket, Door Handle, For Use With 03454390/1

**03454391** Handle, Door, Exterior, Left, 1968-70 B-Body, 1968-76 A-Body

**P3760215** Handle, Door, Exterior, Left, 1970-74 Challenger/ 'Cuda

**77R06034** Handle, Door, Exterior, Right, 1968-70 B-Body, 1968-75 A-Body

**03454390** Handle, Door, Exterior, Right, 1968-70 B-Body, 1968-76 A-Body

**P3760214** Handle, Door, Exterior, Right, 1970-74 Challenger/ 'Cuda



A.



B.



C.



D.



E. 03454391



E. P3760214

RESTORATION

## INTERIOR/BODY

### MIRRORS

#### A. Mirrors

Forget about paying an inflated price at a swap meet for a chrome mirror that's scratched or pitted. This brand-new reproduction not only looks great and fits perfectly. New hardware is included.

77R06065	Mirror, Gasket, 1971 E-Body, Set
77R06111	Mirror, Left, Remote, Chrome, 5.0"
77R06104	Mirror, Left, Remote, Chrome, 1970 E-Body
77R06110	Mirror, Left, Remote, Chrome, 3.25"
77R06105	Mirror, Left, Remote, Painted, 1970 E-Body
77R06112	Mirror, Left, Remote, Painted, 3.25"
77R06113	Mirror, Left, Remote, Painted, 5.0"
77R06115	Mirror, Right, Non-Remote, Chrome, 5.0"
77R06064	Mirror, Right, Non-Remote, Chrome, 1970 E-Body
77R06114	Mirror, Right, Non-Remote, Chrome, 3.25"
77R06107	Mirror, Right, Non-Remote, Painted, 1970 E-Body
77R06108	Mirror, Right, Non-Remote, Painted, 1970 E-Body
77R06116	Mirror, Right, Non-Remote, Painted, 3.25"
77R06117	Mirror, Right, Non-Remote, Painted, 5.0"



A. 77R06111



A. 77R06104



A. 77R06110



A. 03695508



A. 77R06105



A. 77R06112



A. 77R06113



A. 77R06115



A. 77R06064



A. 77R06114



A. 77R06107



A. 77R06108



A. 77R06073



A. 77R06074



B. 77R06128



C.



D. P5153408

**TRUNK**

**A. Jack Hook**

- 77R06073 Jack Hook, E-Body 100
- 77R06074 Jack Hook, E-Body 101
- 77R06075 Jack Hook, E-Body 102

**RACKS**

**B. Luggage Racks**

- 77R06129 Luggage Rack, Chrome, 1970 Charger
- 77R06128 Luggage Rack, Chrome, E-Body

**BUMPERS/ BUMPERETTES**

**Bumpers (Not Shown)**

- 77R06272 Bumper, Front, Chrome, w/o Bumper Guards, 1968-69 Plymouth B-Body

**LAMPS AND LENSES**

**C. Front Marker**

- 77R06100 Front Marker Assembly, Mounts In The Front Valance, Includes Housing, Pig Tail, and Lens, 1971 'Cuda, Pair
- 77R06095 Front Marker Assembly, Mounts in the Grille, Includes Housing, Pig Tails, and Lenses, 1970 'Cuda, Sold as a Pair
- 77R06086 Lens, Front Marker, Amber, 1970-71 Challenger, Pair

**D. Parking**

- P5153408 Lens, Parking Lamp, Left, 1968-69 Charger
- P5153409 Lens, Parking Lamp, Left/Right, with Gaskets, 1968-69 Charger
- P5153428 Lens, Parking Lamp, Left/Right, with Gaskets, 1968-69 Road Runner and GTX
- P5153410 Lens, Parking Lamp, Right, 1968-69 Charger
- P5153575 Lens, Parking Lamp, Right, 1968-69 Plymouth B-Body

## INTERIOR/BODY

### LAMPS AND LENSES

#### A. Side Marker

- P5153384 Side Marker Lens, Front, Amber, 1969 Super Bee, Coronet R/T, Charger R/T, Road Runner, GTX
- 77R06088 Side Marker Lens, Front, Amber, 1970-71 'Cuda, Set of 4
- 03587436 Side Marker Lens, Front, Amber, 1972-75 B-Body, 1972-74 E-Body, 1972-76 A-Body, 1976-80 F-Body
- P5153386 Side Marker Lens, Rear, Red, 1969 Super Bee, Coronet R/T, Charger R/T, Road Runner and GTX
- 77R06089 Side Marker Lens, Rear, Red, 1970-71 'Cuda, Set of 4
- 77R06032 Side Marker Lens, Rear, Red, 1972-74 B & E Body
- 03587440 Side Marker Lens, Rear, Red, 1972-75 B-Body, 1972-74 E-Body, 1972-76 A-Body, 1976-80 F-Body
- 77R06087 Side Marker Lens, Rear, Red, 1970-71 Challenger, Pair
- P5153387 Side Marker Lens, Front & Rear, 1969 Super Bee, Coronet R/T, Charger R/T, Road Runner and GTX
- 77R06098 Side Marker Vehicle Set, Front & Rear, Each Assembly Includes Housing, Pig Tail, and Lens, 1970-71 'Cuda
- 77R06097 Side Marker Vehicle Set, Front & Rear, Each Assembly Includes Housing, Pig Tail, and Lens, 1970-71 Challenger
- 77R06078 Side Marker Housing, Front, With Pigtail, 1970-71 Challenger, Pair



A. P5153384



A. P5153386

#### B. Tail Light

- 77R06090 Tail Light Lens, Rear, 1971 Charger RT/SE, Pair
- 77R06092 Tail Light Lens, Rear, 1971 Road Runner /GTX, Pair
- 77R06093 Tail Light Lens, Rear, 1971-72 Charger RT/SE, Pair



A. 77R06097



B. 77R06092

#### C. Turn Signal

- 77R06096 Turn Signal Indicator, Top Front Fender, Includes Housing, Lens, Bulb, and Pigtail, 1970 Challenger, Pair
- 77R06099 Turn Signal Indicator, Top Front Fender, Includes Housing, Lens, Bulb, and Pigtail, 1971 'Cuda/Roadrunner, Pair
- 77R06091 Turn Signal Lens, Front, Mounts In Front Valance, 1971 'Cuda, Pair
- 77R06085 Turn Signal Lense, Front, Mounts In The Grille, 1970 'Cuda, Pair



C. 77R06091





A. P5153389



A. 77R06280



A. 77R06256



A. 77R06257



A. 77R06273



A. 77R06277



A. 77R06279



B. P5153420



B. P5153422



B. P5153395



C.

## SHEETMETAL

### A. Front Fender

Why spend a lot of time and money bringing old fenders back to life when you can purchase these competitively-priced brand-new parts? These all-steel fenders are manufactured to original equipment specifications and fit perfectly with no drilling or modifications required.

- 77R06273 Fender, Front, Left, 1970 Barracuda/Cuda
- P5153389 Fender, Front, Left, 1970-71 Challenger
- 77R06275 Fender, Front, Left, 1971 Plymouth Barracuda
- 77R06277 Fender, Front, Left, 1971 Plymouth 'Cuda
- P5153391 Fender, Front, Left, 1972-74 Challenger
- 77R06279 Fender, Front, Left, 1972-74 Plymouth Barracuda/Cuda
- 77R06274 Fender, Front, Right, 1970 Barracuda/Cuda
- P5153390 Fender, Front, Right, 1970-71 Challenger
- 77R06276 Fender, Front, Right, 1971 Plymouth Barracuda
- 77R06278 Fender, Front, Right, 1971 Plymouth 'Cuda
- 77R06280 Fender, Front, Right, 1972-74 Barracuda/Cuda
- P5153392 Fender, Front, Right, 1972-74 Challenger
- 77R06256 Fender, Inner Panel, Left, 1970-74 E-Body, 1971-72 B-Body
- 77R06257 Fender, Inner Panel, Right, 1970-74 E-Body, 1971-72 B-Body
- 77R06122 Fender Gill Mounting Plates, 1971 'Cuda, Set of Four
- 77R06066 Fender Gills, 1971 'Cuda, Includes Gasket, Sold as Kit of 8

### B. Quarter Panel

Get it right the first time. Mopar's new steel replacement Quarter Panels are manufactured to O.E. specifications and are exact reproductions with no modifications. Installation requires welding.

- P5153429 Quarter Panel, Left, 1968 2-Door B-Body Hardtop
- P5153431 Quarter Panel, Left, 1969 2-Door B-Body Hardtop
- 77R06281 Quarter Panel, Left, 1970 Plymouth B-Body 2-Door Hardtop
- P5153419 Quarter Panel, Left, 1970-71 Barracuda
- P5153395 Quarter Panel, Left, 1970-71 Challenger
- P5153421 Quarter Panel, Left, 1972-74 Barracuda Hardtop
- P5153397 Quarter Panel, Left, 1972-74 Challenger
- P5153430 Quarter Panel, Right, 1968 2-Door B-Body Hardtop
- P5153432 Quarter Panel, Right, 1969 2-Door B-Body Hardtop
- 77R06282 Quarter Panel, Right, 1970 Plymouth B-Body 2-Door Hardtop
- P5153420 Quarter Panel, Right, 1970-71 Barracuda
- P5153396 Quarter Panel, Right, 1970-71 Challenger
- P5153422 Quarter Panel, Right, 1972-74 Barracuda Hardtop
- P5153398 Quarter Panel, Right, 1972-74 Challenger

### C. Cowl Panel

- 77R06258 Cowl Panel, Lower Left Side, 1970-74 E-Body
- 77R06259 Cowl Panel, Lower Right Side, 1970-74 E-Body

## INTERIOR/BODY

### SHEETMETAL

#### A. Floor Pan

- 77R06261 Floor Pan, Center, Left, With Rear Seat Footwell, 1970-74 E-Body
- 77R06262 Floor Pan, Center, Right, With Rear Seat Footwell, 1970-74 E-Body
- 77R06260 Floor Pan, Front, 1970-74 E-Body, 1971-74 B-Body
- 77R06263 Floor Pan, Rear, Under Rear Seat Footwell, 1970-74 E-Body

#### B. Tail Panel

- 77R06268 Tail Panel, Rear, 1970 Challenger

#### C. Trunk Floor

- 77R06266 Trunk Floor, Complete, 1970-74 Dodge Challenger
- 77R06271 Trunk Floor, Complete, 1970-74 Plymouth Barracuda
- 77R06267 Trunk Floor, Brace, 1970-74 E-Body, 1971-73 B-Body

### WHEELHOUSE

#### D. Outer Wheelhouse

If a quarter panel needs replacement, it's a good bet the Outer Wheelhouse does, too. These steel reproduction units install easily requiring only minor welding, and add a finishing touch to any restoration. Sold individually.

- P5153433 Outer Wheelhouse, Left, 1968-70 B-Body Models- Road Runner/GTX
- P5153403 Outer Wheelhouse, Left, 1968-70 Coronet and Charger
- P5153423 Outer Wheelhouse, Left, 1970-74 Barracuda
- P5153399 Outer Wheelhouse, Left, 1970-74 Challenger
- P5153404 Outer Wheelhouse, Right, 1968-70 Coronet and Charger
- P5153434 Outer Wheelhouse, Right, 1968-70 Road Runner/GTX
- P5153424 Outer Wheelhouse, Right, 1970-74 Barracuda
- P5153400 Outer Wheelhouse, Right, 1970-74 Challenger

### VALENCE

#### E. Front Valance

Don't let a badly dented or damaged front valance panel ruin the look of your classic. Replace it with this high-quality steel Front Valance reproduction unit. Fits perfectly, with no modifications necessary.

- 77R06081 Valance, Front Insert, Mounts on the inside of the valance, 1971 'Cuda
- P5153407 Valance, Front, 1968-69 Charger
- P5153415 Valance, Front, 1970 and 72-74 Barracuda
- P5153388 Valance, Front, 1970-71 Challenger



A. 77R06261 & 77R06262



A. 77R06260



A. 77R06263



B.



C. 77R06267



C. 77R06266



C. 77R06271



D.



E.



A.



B. Road Runner



B. P2842756



B. P2842757



B. P2842873



B. P2842758



B. P3672656



B.



C. P3612874



C. P3505419



C. P3680304



C. P3446861

VALENCE

A. Rear Valance

Over time, the rear valance panel is exposed to a lot of abuse. Mud, rocks, parking curbs-you name it. If yours is less than perfect, replace it with this high-quality steel Rear Valance reproduction. Installs with minimal modifications and will look great for years to come.

- P5153426 Valance, Rear, With Exhaust Cutouts, 1970-74 Barracuda
- P5153425 Valance, Rear, Without Exhaust Cutouts, 1970-74 Barracuda
- P5153412 Valance, Rear, 1968 Charger
- P5153413 Valance, Rear, 1969-70 Charger
- P5153402 Valance, Rear, With Dual Exhaust Cutouts, 1970-74 Challenger
- P5153401 Valance, Rear, Without Dual Exhaust Cutouts, 1970-74 Challenger

Note: Charger requires cutting/welding and replacement corner pieces.

EMBLEMS AND DECALS

B. Decals, Road Runner

Mopar offers replacement Decals for doors, hoods, and decklids to perfectly match the style you need. If your decals are damaged or badly faded, replace them with these brand-new pieces.

- P2842756 Road Runner Decal, 1968 Road Runner, Deck Lid
- P2842873 Road Runner Decal, 1968 Road Runner, Deck Lid
- P2842757 Road Runner Decal, 1968 Road Runner, Left Door
- P2842758 Road Runner Decal, 1968 Road Runner; Right Door
- P4022410 Road Runner Decal, 1968 Road Runner; Right Door
- P4022411 Road Runner Decal, Right
- P3749059 Road Runner Decal, Road Runner with Plymouth, 1971-74
- P3672656 Road Runner Decal, Standing Style Road Runner with Helmet Inside Circle, 1971-75 Road Runner, Rear Deck Lid

C. Emblems, A-Body

Mopar Emblems are exact, high quality reproductions. They are manufactured using the same materials and attention to detail as the originals. Don't put up with damaged, pitted or scratched nameplates anymore-replace them with these eye-catching works of art.

- P3612874 340 Emblem, 1970 Swinger, 1972 Demon, 1973 Dart Sport
- P3505419 Dart Emblem, 1970-75 Dart
- P3680304 Duster Emblem, 1972-75 Duster
- P3446861 Swinger Emblem, 1970-75 Swinger, Deck Lid and Quarter Panel

## INTERIOR/BODY

### EMBLEMS AND DECALS

#### A. Emblems, B-Body

Mopar Emblems are exact, high quality reproductions. They are manufactured using the same materials and attention to detail as the originals. Don't put up with damaged, pitted or scratched nameplates anymore—replace them with these eye-catching works of art.

P3573632	340 Magnum Emblem, 1972-73 Charger, Hood
P3443627	383 Magnum Emblem, 1971 Charger Super Bee, Hood
P3574059	400 Magnum Emblem, 1972-74 Charger, Hood
P3613278	440 Emblem, 1969 GTX, 1969-70 Coronet R/T and Super Bee, Hood
P3443516	440 Magnum Emblem, 1971-74 Charger, Hood
P2841886	Charger Emblem, 1966-74 Charger
P3504807	Charger Emblem, 1971-74 Charger, Front Fender
P2785518	GTX Emblem, 1967 GTX, Front Fender
P3504289	GTX Emblem, 1969-71 GTX, 1972-74 Road Runner, Quarter Panel and Deck Lid
P3680160	GTX Emblem, 1973-74 GTX Front Fender, 1970 GTX Road Runner Rear Deck Lid
77R06102	Header Panel Medalion, Mounts In The Center Of The Header Panel, 1972 Roadrunner
P3691667	Magnum Emblem, 1972-74 Charger, Hood
P2998042	Plymouth Emblem, 1970 Road Runner and GTX, 1971 Barracuda, Hood
P2785791	Plymouth Emblem, 1970-72 Duster, 1968-69 Road Runner and GTX, Hood
P3444927	Plymouth Emblem, 1970-72 Road Runner/GTX/Barracuda/Duster, Hood and Deck Lid
P2785579	R/T Emblem, 1968 Coronet R/T, Front Fender
P2786711	R/T Emblem, 1968 Coronet R/T, Grille
P2901812	R/T Emblem, 1969 Charger R/T, Coronet R/T, Quarter Panel
P2898886	R/T Emblem, 1969 Coronet R/T, Grille
P3505490	Road Emblem, 1969-75 Road Runner
P3505491	Runner Emblem, 1969-75 Road Runner
P2782966	Special Edition Emblem, 1966-70 Charger and Coronet
P2964635	Super Bee Emblem, 1969 Super Bee, Deck Lid
P2949303	Super Bee Emblem, 1969 Super Bee, Grille
P2998065	Super Bee Emblem, 1970 Super Bee, Hood
P2998749	Super Bee Emblem, 1970 Super Bee, Power Bulge Hood



A. P3574059



A. P3613278



A. P3443516



A. P2841886



A. P3680160



A. P3691677



A. P3444927



A. P2901812



A. P3505490



A. P3505491



A. P2782966



A. P2998065



A. P3443247



A. P3691468



A. P2998801



A. P2998800



A. P3462491



A. P3444938



A. P5153394



A. P3443159



A. P2998796



A. P2998798



B.

EMBLEMS AND DECALS

A. Emblems, E-Body

Mopar Emblems are exact, high quality reproductions. They are manufactured using the same materials and attention to detail as the originals. Don't put up with damaged, pitted or scratched nameplates anymore-replace them with these eye-catching works of art.

- P3443247 340 Four-Barrel Emblem, 1970-73 Challenger, Hood
- P3691468 360 Four-Barrel Emblem, 1974 Challenger, Hood
- P2998801 383 Magnum Emblem, 1970-71 Challenger, Hood
- P2998800 426 Hemi Emblem, 1970-71 Challenger, 1971 Charger, Hood
- P2998802 440 Magnum Emblem, 1970 Challenger, 1972-74 Charger, Hood
- P2998804 440 Six Pack Emblem, 1970-71 Challenger, 1971 Charger, Hood
- P3462492 440 Six Pack Emblem, 1970-71 Challenger, Left, Hood
- P3462491 440 Six Pack Emblem, 1970-71 Challenger, Right, Hood
- P3444938 Challenger Emblem, 1970-74 Challenger
- P5153394 Challenger R/T and Rallye, 1970-74, Hood Scoop Ornament Set, Left/Right
- P3443159 'Cuda 340 Emblem, 1970-73 'Cuda, Hood
- P2998796 'Cuda 383 Emblem, 1970-71 'Cuda, Hood
- P2998798 'Cuda 440-6 Emblem, 1970-71 'Cuda, Hood
- P3445223 R/T Emblem, 1970 Challenger R/T, Fender and Deck Lid
- P2998547 R/T Emblem, 1970-71 E-Body, Grille

B. Emblems, D-O-D-G-E

Mopar Emblems are exact, high quality reproductions. They are manufactured using the same materials and attention to detail as the originals. Don't put up with damaged, pitted or scratched nameplates anymore-replace them with these eye-catching works of art.

- P2579655 D Emblem, 1966-74 Dodge Vehicles
- P2579656 O Emblem, 1966-74 Dodge Vehicles
- P2579657 G Emblem, 1966-74 Dodge Vehicles
- P2579658 E Emblem, 1966-74 Dodge Vehicles

## INTERIOR/BODY

### EMBLEMS AND DECALS

#### A. Decals, Hood

Mopar offers replacement Decals for doors, hoods, and decklids to perfectly match the style you need. If your decals are damaged or badly faded, replace them with these brand-new pieces.

- P3412427 440 6-bbl Decal, 1969-1/2 Road Runner, Hood
- P2998896 440+6 Decal, 1970 Road Runner/GTX, Hood
- 77R06176 Shaker Decal, Hood
- P3412423 SIX PACK Decal, 1969-1/2 Super Bee, Hood

#### B. Decals, Miscellaneous

Mopar offers replacement Decals for doors, hoods, and decklids to perfectly match the style you need. If your decals are damaged or badly faded, replace them with these brand-new pieces.

- P5153481 392 Hemi Decal
- 77R06180 Chrysler Airtemp Decal, Window
- 77R06179 Factory Race Car Disclaimer Decal, 1964-65 and '68 Super Stock Hemi

### WHEEL COMPONENTS

#### C. Trim Rings

These 14" and 15" Trim Rings for Rallye, Road and Steel wheels are available in either chrome or brushed finish. They are made from the original tooling and have the correct retaining ring for a proper fit.

- P5153310 Trim Ring, Deep Dish, Bright Finish, 15" X 6.5" Rallye Wheel, Road Wheel and Steel Wheel Applications,

#### D. Rallye Wheel Center Caps

Made from original tooling with correct astrotone finish.

- P3461458 Center Cap, Rallye Wheel, 4.500" Bolt Circle, All 1972-75 Applications
- P3461066 Center Cap, Rallye Wheel, 4.500" Bolt Circle, Dark Argent Finish, All 1971 Applications
- P4510579 Center Cap, Rallye Wheel, 4.500" Bolt Circle, Light Argent Finish, All 1970 Applications
- 77R06144 Center Cap, Rallye Wheel, Small Bolt Pattern, 1970 A-Body, Set of 4
- 77R06143 Center Cap, Rallye Wheel, Small Bolt Pattern, 1971 A-Body, Set of 4
- P3580466 Center Dome, Road Wheel, 1966-78

#### E. Wheel Stud Sets

Studs are heavy-duty and extra long to allow use of wheel spacers. Set contains ten studs.

- P4120610 RWD Wheel Stud Set — 1/2" Diameter, Disc Brakes (A/ B/ E- Bodies)
- P4120625 RWD Wheel Stud Set — 1/2" Diameter, Drum Brakes (A/ B/ E- Bodies)



A. P3412427



A. P2998896



A. 77R06176



A. P3412423

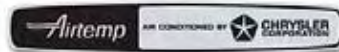

B. 77R06180

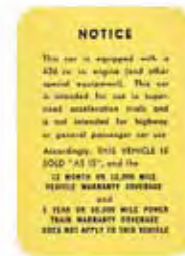

B. 77R06179



B. P5153481



C.



D.



E.

## WHEEL COMPONENTS

### A. Lug Nut, Chrome

These O.E.-quality Chrome Lug Nuts are designed for use all Road and Rallye wheel applications along with the 1969 1/2 A12 six-barrel Road Runner and Six Pack Super Bee vehicles. Available in left- and right-hand threads. Sold individually. (1/2-20 SAE thread)

02823849 Lug Nut, Chrome, Left-Hand Thread

02823848 Lug Nut, Chrome, Right-Hand Thread

### B. Wheel Paint

Polyurethane formulated Argent Silver paint gives a like-new luster to wheels, grilles and light bezels, for that factory look. Also protects wheels from rust and pitting.

P4529876 Wheel Paint, Argent



A.



B.

Questions? Call the Mopar Direct Connection Techline at 1-888-528-HEMI (4364)

<sup>1</sup> Not legal on pollution-controlled vehicles or vehicles registered for highway use.





## DODGE, CHRYSLER AND MOPAR®: Driven

What could the iconic Dodge Viper possibly have in common with latest Chrysler and Dodge vehicles? Under the skin, they're all Mopar®. From ten cylinders to four, the heart that beats within is Mopar made and Mopar maintained. For performance parts, where it comes from is as important as where it goes. Stick to Mopar and you can't go wrong.

PERFORMANCE





VIPER 12



P  
R  
I  
O  
R  
I  
T  
Y  
P  
E  
R  
F  
O  
R  
M  
A  
N  
C  
E



## VIPER

### BRAKES

#### A. Brake Rotors

The Viper SRT10 benchmark brakes are taken to the next level in the 2008 Dodge Viper SRT10 ACR. StopTech two-piece, slotted, lightweight rotors combine with the Viper SRT10's Brembo calipers (standard on Viper) to reduce rotating inertia and unsprung mass, improve brake cooling, and significantly reduce fade even under extreme conditions. The StopTech rotors feature a patented curved-fin design, a key element in improving brake cooling. The StopTech brake rotors combined with the Michelin Pilot Sport Cup Tires and Sidewinder lightweight wheels combine to reduce 60 pounds of unsprung, rotating mass. The 2008 Dodge Viper SRT10 ACR stops from 60 MPH in less than 100 feet.

<sup>1</sup> P5155125 Rotors, Brake, Front Set, Two Piece Slotted Design, 2003-08 Viper

<sup>1</sup> P5155126 Rotors, Brake, Rear Set, Two Piece Slotted Design, 2003-08 Viper



### VIPER SRT10 POWER KIT

#### B. Engine Controller - Race

The Mopar Race Engine Controller for the Viper SRT10 is specifically calibrated for use with the Race Camshaft (P4510171) and the Viper 3-inch Race Exhaust (P4510176). It optimizes fuel and air tables for peak performance without catalytic converters, removes the skip shift feature (found on the production model), and is calibrated for premium pump fuel (91 octane minimum). For race use only.

<sup>1</sup> P4510172AB Engine Controller, Race, 2003-06 Viper SRT10

**IMPORTANT NOTICE:** This device is not legal for use on pollution-controlled vehicles certified for use on streets or highways. Once this device is installed, use of the vehicle on a street or highway is a violation of the Clean Air Act, potentially subjecting the operator and the installer to civil penalties of up to \$32,500 per vehicle depending on the circumstances.

#### C. Camshaft - Race

Based on the Competition Coupe camshaft. Uses production springs and rocker arms to offer a 6-8 horsepower increase at top end of RPM range. Recommended for use with Race Engine Controller (P4510172AB) and 3-inch Race Exhaust (P4510176).

##### Features:

- Cam lift: 0.320" Intake and 0.320" Exhaust
- Duration at 0.050": 220.00 Intake/230.5 Exhaust
- Cam Centerline = 117° after top dead center

<sup>1</sup> P4510171 Camshaft, Race, 2003-06 Viper SRT10

A. P5155126



B.



C.



A.



B.



C.



D.

## VIPER SRT10 POWER KIT

### A. Exhaust System - Race

The Mopar 3-inch Race Exhaust System provides low restriction from manifold to tip. Catalytic converters are eliminated (upstream and downstream), and it has a side exit from the sill that removes H-pipe crossover. This system is more than 30 lbs. lighter than the production exhaust system. The exhaust muffler is tuned to minimize noise where track restrictions are present, yet it yields a deep sounding exhaust note. Recommended package includes Race Engine Controller (P4510172AB) and Race Camshaft (P4510171). Total performance increase when Controller, Camshaft and Exhaust are used together: Horsepower increase = 44 bhp at 4,800 rpm, Torque increase = 48 ft.-lbs. of torque at 4,800 rpm. Not for Production Vehicles - Comp Coupe Only.

<sup>1</sup> **P4510176** Race Exhaust System, Exits On Each Side, 3.0" Pipe, 2003-06 Viper Race Exhaust system, Viper Comp Coupe 8.3L

## VALVES AND VALVE TRAIN HARDWARE

### B. Valves

Stainless Steel Valves offer improved durability. Standard stem length (5.726") with oversize head diameters. Swirl-polished underhead area, chromed stem and hardened tip. Cylinder Head (P4876869) is no longer available through Mopar.

<sup>1</sup> **P5007511** Valve, Exhaust, 1.60" Diameter

<sup>1</sup> **P5007510** Valve, Intake, 2.02" Diameter

### C. Rocker Arm Assembly - Race

Tested and proven to be victorious on the "24 Hours of Le Mans" GTS-R. Features individual shaft-mounted rockers with needle bearings on shafts and rocker tips, forged aluminum 1.7:1 ratio rockers, 12-point aircraft quality mounting hardware, and rocker arm adjusters. Rockers mount to one-piece CNC steel billet bar for positive alignment.

<sup>1</sup> **P5007049** Rocker Arm Package, Race, 1997-02 Viper RT/10

## IGNITION AND ELECTRONICS

### D. Spark Plug Wire Sets

These suppression-type Spark Plug Wire Sets are compatible with the production Engine Control Unit (ECU). High-temperature, 8.5 mm diameter material for added durability. Individually numbered spark plug terminals and boots. Sold in sets only.

**P5007159** Wire Set, Spark Plug, 8.5 mm, Coils at Back of Engine, 1996.5-01 Viper RT/10 and 1996-01 GTS

**P4876435** Wire Set, Spark Plug, 8.5 mm, Coils Under Intake Manifold, 1992-96.5 Viper RT/10

## VIPER

### IGNITION AND ELECTRONICS

#### A. Engine Controller

Designed for race only applications, the Stage 1 Engine Controller has modified spark and fuel tables which function when "power adders" like headers, cat-back exhaust, aftermarket cams and cold air intake systems are used. The computer senses the additional air flow and will compensate with appropriate fuel and spark to maximize performance.

##### Features:

- \* Power adders can be used without turning on dash warning lights. Catalysts and O2 sensors can be removed without tripping warning lights or causing limp mode to activate
- \* Chassis dyno results showed a slight HP gain (approx 10 hp) on a stock ACR but the intent of this controller is to work with power adders to maximize performance
- \* The revised fuel/spark tables are intended for power levels below 700 hp. This controller is not intended for use with nitrous, superchargers, or packages that go above 700 hp. It might work depending on your setup, but it wasn't designed to function in that range
- \* The 1-4 skip shift feature in the production calibration has been eliminated
- \* Requires the use of 93 octane fuel only
- \* The rev limit has been increased from 6400 rpm to 6500 rpm
- \* Tachometer settings have been adjusted for updates every 25 RPM (vs. every 100 RPM)
- \* Increases engine idle speed from 700 rpm to 750 rpm
- \* The ETC pedal / throttle MAP has been refined which improves pedal feel
- \* Tested using rear axle ratios between 3.07:1 to 4.10:1

<sup>1</sup> P5155254AB Engine Control Module, Stage 1, 2008-10 Viper

**IMPORTANT NOTICE:** This device is not legal for use on pollution-controlled vehicles certified for use on streets or highways. Once this device is installed, use of the vehicle on a street or highway is a violation of the Clean Air Act, potentially subjecting the operator and the installer to civil penalties of up to \$32,500 per vehicle depending on the circumstances.

#### B. Wiring Harness

For use with Viper V10 crate engines in non-Viper installations. Includes relays and factory connectors for sensors, sending units, ignition, etc. Features extra long wire leads for universal applications. Instructions and wiring diagram included.

<sup>1</sup> P5153824 Crate Engine Adapter Harness, Viper V10, (Provides PDC, Headlamp, and Dash Function)

<sup>1</sup> P5007142 Wiring Harness, Viper Crate Engines, 8.0L

### COOLING SYSTEMS

#### C. 180 Degree Race Thermostat

Help your engine run cooler under track conditions. Thermostat includes gaskets for both heavy and lightweight engines.

<sup>1</sup> P4876900 Thermostat, Race, 180 Degree, 1992-02 Viper



A. P5155254

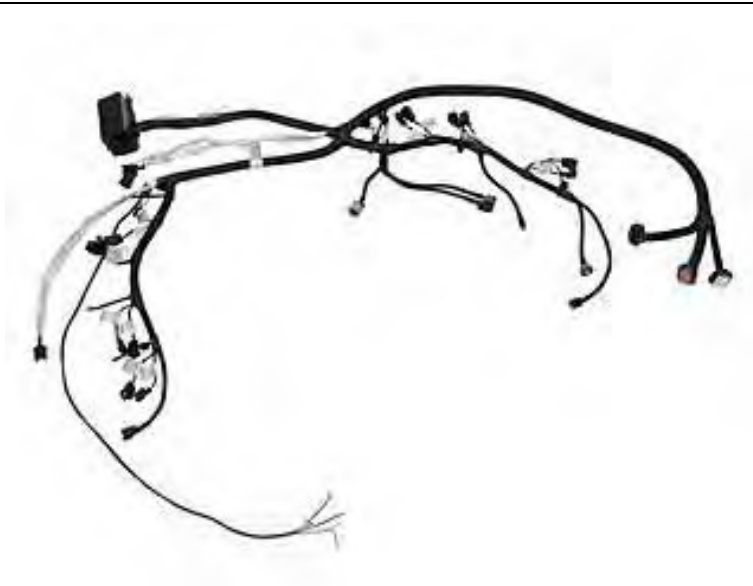

B.



C.



A.



B.



C.



C.

## COOLING SYSTEMS

### A. Fan and Control Module

For use with Viper V10 Crate Engine in non-Viper installations. Use with Viper wiring harness (P5007142). Height: 18.00"; Width 25.50"; Thickness: 4.50".

- <sup>1</sup> P5007266 Fan Assembly, Includes Fan Blade, Motor, Wires, and Shroud, 40 Amp Draw, High Speed 2370 CAM, Low Speed 2020 CAM, Viper V10 Crate Engine

### B. Underdrive Crank Pulley and Drive Belts

Originally developed for the Competition Coupe. Improves water pump efficiency at high RPMs. Constructed of hard-coated aluminum. Requires one of the available Accessory Drive Belts.

- <sup>1</sup> P4510177 Pulley, Crank, Underdrive, 2003–05 Viper SRT10
- <sup>1</sup> P4510225 Drive Belt, Accessory, 2003-04 Viper
- <sup>1</sup> P4510224 Drive Belt, Accessory, for Vehicles with A/C, 2003-05 Viper SRT10
- <sup>1</sup> P4510233 Drive Belt, Accessory, for Vehicles without A/C, Includes Belt and Three Bolts, 2003–05 Viper SRT10

## DIFFERENTIAL COMPONENTS

### C. Differential Assemblies

Complete Differential Assemblies with all new components and Mopar Performance Parts gear sets fully assembled to production specifications.

Features:

- Aluminum housing with specially cast-in bosses for Mopar Performance differential cooler fittings
- Bosses are drilled, tapped and plugged in three places, ready for cooler fitting installation
- Production Trac-Lok with upgraded 7/16-inch diameter ring gear retaining bolts
- Improved design pinion seal
- Choice of two Mopar Performance gear sets

- <sup>1</sup> 05038307AE Differential Assembly, 3.06:1 Gear Set, 2008 Viper differential assembly with Visco Loc limited slip differential. This is a direct replacement for 2003-06 and 2008 differential assemblies. Drop your lap times with more forward bite with the improvements to the Visco Loc limited slip
- <sup>1</sup> P5007403 Differential Assembly, 4.10:1 Gear Set, Less Cover/Support, Direct Replacement for Production Unit, Including Production Trac Loc, but Featuring Center Housing Having Three Cast-In Bosses for Differential Cooler Fittings

# VIPER

## DIFFERENTIAL COMPONENTS

### A. Ring and Pinion Sets- HD

Stronger than other units currently available in the aftermarket. Note that these are only for Dana Super 44 differentials with 3/8-inch diameter ring gear retaining bolts offered in 1996-06 Viper RT/10 and GTS.

- <sup>1</sup> P5007022 Ring and Pinion, 3/8" Diameter, 3.73 Gear, 1996-00 Viper RT/10/GTS
- <sup>1</sup> P5007043 Ring and Pinion, 3/8" Diameter, 4.10 Gear, 1996-00 Viper RT/10/GTS

### B. Ring and Pinion Sets - Race

Upgraded to stronger 7/16-inch diameter ring gear retaining bolts. Requires Trac-Lok (P5007555, no longer available through Mopar) when installed in 1996-2000 Dana Super 44 differential.

- <sup>1</sup> P5007526 Ring and Pinion Set, Race, 7/16" Diameter, 3.73 Gear, 1996-05 Viper

### C. Differential Cooling Package

This is a complete differential cooling package, equipped with cooler, pump, fans, duct work, stainless steel lines, wiring, and all fittings. Electric cooling fans provide a high velocity of air travel through the cooler for optimal performance. The electrical circulating pump engages at 205 degrees° (when the differential reaches its operating temperature) and will continue to operate until the differential oil temperature is reduced.

- <sup>1</sup> P5155826 Cooling Package, Differential, 2010 Viper

## TRANSMISSION COMPONENTS

### D. Hurst Short-Throw Shifter

Shift throw reduced by 40%. One-piece shift stick and gold anodized billet aluminum construction for durability. Exclusive Black Viper Head Shift Knob is available in your choice of four logo colors and must be ordered separately (shift knob height is reduced for competition feel). This shifter handle does not accept the factory knob, but is designed to accept the shift knobs listed below that have a 1/2-inch - 20 UNF thread.

- P4510168 Shifter, Short-Throw, Hurst, 1992-06 Viper
- P5153302 Shift Knob, Blue Viper Logo
- P5153300 Shift Knob, Red Viper Logo
- P5153301 Shift Knob, Silver Viper Logo
- P5153303 Shift Knob, Yellow Viper Logo

### E. Shift Knob

- P5155842 Shift Knob, W/ Lever, Production Replacement. Reduces shift travel and shifter height. 2010 Viper

### Six Speed Transmission Kit (Not Shown)

- P5155123 Transmission, 2008 Viper 6-SPD. Includes Transmission, Shifter Base, Prop Shaft, and Crossmember



A.



B.



C.



D.



E.





A.



B.



C.

## TRANSMISSION COMPONENTS

### Gear Upgrade- 5th. (Not Shown)

This fifth gear upgrade kit is intended to give a closer gear ratio for fifth gear, giving the car a sportier feel while still maintaining the fuel economy of sixth gear. This kit changes the fifth gear ratio from 0.74:1 to 0.796:1.

**P5155799** Gear Upgrade, 5th. Gear, Manual Transmissions, 2009-11 Challenger, 2008-09 Viper

### A. Flywheel- Lightweight

High-strength alloy steel flywheel is a direct replacement for stock SRT10 part and uses production clutch assembly. Reduction of 9.4 lbs. (31%) in flywheel mass, and 39% in flywheel rotating inertia. No release bearing changes, crank trigger changes or calibration required.

**P4510169** Flywheel, Lightweight, 2003-06 Viper SRT10

### Clutch Kit (Not Shown)

**P5155122** Clutch Conversion Kit, Converts a 2005-06 Viper to a 2008 Dual Disc Clutch, Requires P5155123. Not compatible on Vipers with a Flywheel Crank Trigger

### B. High-Durometer Transmission Mounts

Urethane mount reduces transmission movement under high-load conditions. Improved life compared to stock rubber mount. Same as used on Viper Competition Coupe.

**P4510179** Transmission Mount, High-Durometer, 2003-05 Viper SRT10

## SUSPENSION UPGRADES AND COMPONENTS

### C. Stage 3 Coilover Suspension Kit- Race

Coilover Suspension System:

- Two way adjustable
- Lightweight aluminum construction
- Double adjustable (compression and rebound)
- Ride height adjustable
- Bridges the gap between street systems and full race systems

<sup>1</sup> **P5155324** Coilover Suspension Kit, ACR, Stage 3, 2008-09 Viper SRT10

<sup>1</sup> **P4510951** Coilover Suspension System, 2-Way Adjustable, 2003-09 Viper SRT10 Coupe, (Non-ACR vehicles)

## VIPER

### SUSPENSION UPGRADES AND COMPONENTS

#### Spring/Damper Assemblies (Not Shown)

Standard on all ACR-X Race Cars, these race tuned spring and damper assemblies are must for the serious driver. Ride height is adjustable through threaded spring perches and independently adjustable for both compression and rebound (14 compression settings/ 18 rebound settings). Recommended for use with with ACR anti-roll bars and aerodynamic packages. Front springs are 140N/mm and the rear springs are 260 N/mm. Monotube aluminum body. 60mm ID Race Springs. 2010 Viper.

**P5155835** Spring/Damper Assembly, Front, Set of Two, 2010 Viper

**P5155836** Spring/Damper Assembly, Rear, Left, 2010 Viper

**P5155837** Spring/Damper Assembly, Rear, Right, 2010 Viper

#### A. Heat Shield Boots

These flexible Heat Shield Boots lower joint temperature and protect the rubber boots from thermal cracking. Heat shields slip over existing rubber boots — no modifications required. Recommended for racing use, but also good for street applications. Sold individually.

**P4510144** Heat Shield Boot, Ball Joint, 1996–06 Viper

**P5154374** Heat Shield Boot, Tie Rod, 1996-09 Viper

#### B. Solid Steering Gear Mounts

Improves turning and handling response. A direct replacement for rubber isolator mounts found in production Vipers. Constructed of lightweight aluminum for strength and durability.

<sup>1</sup> **P4510204** Steering Isolator Mounts, Solid, 1994-06 Viper

### AIR SYSTEMS

#### C. Air Filters- O.E. Performance Replacement

Constructed with factory tight seals, engineering level polyurethane, deep four-ply pleats of oiled cotton gauze and two layers of aluminum screen. This filter offers high flow and low restriction, better throttle response, and increased filtration and horsepower. Filters are washable and reusable and come pre-oiled.

**P4510940** Air Filter, High Flow, O. E. Replacement, 2003–06 Viper SRT10

#### D. Smooth Bore Inlet Hoses

ACR production part with correct molded bend and hose end diameters. Provides increased airflow with less turbulence for more horsepower. Five-ply polyester-reinforced silicone shell eliminates collapse due to high vacuum. Features a fluoro-silicone liner for fuel/oil protection and 100,000+ mile durability. Includes two hoses (99-02).

**P5007362** Inlet Hoses, Smooth Bore, Black, Viper RT/10 and GTS



A.



B.



C.



D.



A.

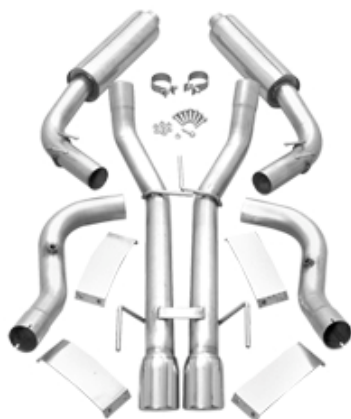

B.



C.



D.

## EXHAUST SYSTEMS

### A. Headers- Race

These race headers are all constructed of heavy duty stainless steel. They are equipped with a "5 tube flange" that allows easy installation without removal of the engine. A 5 into 1 collector allows for maximum torque and horsepower gain. The primary tube diameter is 1-3/4". Expect up to a 40 hp gain when equipped with the race exhaust system and performance engine controller. Additional installation recommendations include forged pistons and spark plug wire heat socks. Note that the header gasket and J-pipe are not included with P5155828.

**P5155830** Gasket, Exhaust Header, Five Tube Flange, 2010 Viper

<sup>1</sup> **P5155828** Headers, Race, Stainless Steel, 2010 Viper

**P5155829** J-Pipe, Exhaust, 2010 Viper

### Exhaust System- Race (Not Shown)

A Low back pressure exhaust system specifically tuned for Mopar Race Headers (P5155828). Features a pressure drop equal to that of a straight pipe. The 4 tube perforated design reduces exhaust noise with minimal size and weight.

<sup>1</sup> **P5155831** Exhaust System, Stainless, Race Only, W/ Tips, 2010 Viper

**P5155833** Exhaust Tip, Left, 2010 Viper

**P5155832** Exhaust Tip, Right, 2010 Viper

### B. Cat-Back Exhaust System- GTS-R/T

Offers low restriction with a performance sound. Made from 304 stainless steel, this system features 3-inch diameter tubing for high-volume flow and factory-style band clamps. Exclusive laser-etched Viper logo on polished stainless steel exhaust tips with rolled rims. Bolt-on replacement for production rear exit exhaust.

<sup>1</sup> **P5007274** Cat-Back Exhaust System, Dual Rear Exit Viper Etched Tips, 1996-99 Dodge Viper GTS/RT-10

### C. Cat-Back Exhaust System- SRT 10

Add some extra bite to your Viper. This Cat-Back Exhaust System features stainless steel construction (including the muffler) with mandrel-bent tubing, which provides horsepower and torque gains, improved fuel economy, and a deeper tone. Includes two mufflers, right and left turn out assemblies, and four 2-1/2-inch clamps.

<sup>1</sup> **P4510608** Cat-Back Exhaust System, Single Angle-Cut Tips, Exits On Each Side, 2.50" Pipe, 2003-06 Dodge Viper, SRT10, 8.3L

## GTS-R ENGINE PARTS

### D. Valve

Stainless steel for improved durability. Stem length is 0.100-inch longer than stock, and head diameter is oversized. Swirl-polished overhead area, chromed stem and hardened tip.

<sup>1</sup> **P5007514** Valve, Exhaust, 1.60" Diameter, 5.826" Stem, Viper GTS-R

VIPER

## GTS-R ENGINE PARTS

### A. GTS-R 8.5 mm Spark Plug Wire Set

For use on GTS-R chassis with front mounted coils only. Suppression-type compatible with Engine Control Unit. High-temperature, 8.5 mm diameter material for added durability. Individually numbered for each cylinder. Production-style spark plug terminals and boots. Sold as a set.

**P4876844** Wire Set, Spark Plug, 8.5 mm, GTS-R

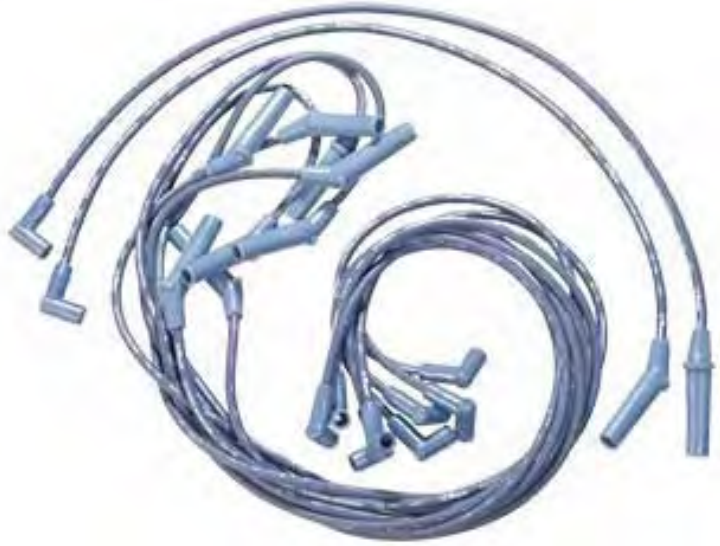

A.

---

## EXTERIOR BODY COMPONENTS

## A. Wing



A.



A.

The 2008 Dodge Viper SRT10 ACR exterior styling cues offer not only bold aesthetics, but functional benefits on the track. The "Race" kits include a variable geometry "fanged" front splitter, an adjustable rear wing sculpted by CFD (Computational Fluid Dynamics) and optimized front dive planes. These new aerodynamic devices are formed in high-performance autoclaved carbon-fiber. By using both unidirectional and woven laminates, the aero equipment is optimized for the minimum weight possible.

The splitter and dive planes feature a clear-coated carbon-fiber weave on all Viper SRT10 ACR models. The front splitter includes three removable rub strips that provide protection and wear resistance. Supported by stainless steel tension cables, the splitter is designed to absorb the energy from minor upward deflections.

The Dodge Viper SRT10 ACR aerodynamics are tuned and balanced to maximize downforce (up to 1,000 lbs.) and provide increased levels of lateral grip. Each Viper SRT10 ACR also includes a track extension that replaces the center splitter rub strip and fills out the fanged splitter scallop for closed-circuit events. The aerodynamic effect of the track extension is a reduction in overall drag and an increase in front downforce of nearly one-third. The front fog lamps have been deleted and replaced with lightweight filler panels.

- <sup>1</sup> P5155265 Wing, Long, Carbon Fiber, Includes Wing, Dive Plane Asm., Front Splitter, Track Extension, and Fog Light Close Outs, 2003-06 Gen III, 2008-09 Gen IV non-ACR or Without the ARY Package, Race/Coupe Only
- <sup>1</sup> P5155272 Wing, Long, Primed, Includes Wing, Dive Plane Asm., Front Splitter, Track Extension, and Fog Light Close Outs, 2003-06 Gen III, 2008-09 Gen IV non-ACR or Without the ARY Package, Race/Coupe Only
- <sup>1</sup> P5155273 Wing, Short, Primed, Includes Wing, Dive Plane Asm., Front Splitter, Track Extension, and Fog Light Close Outs, 2003-06 Gen III, 2008-09 Gen IV non-ACR or Without the ARY Package, Coupe Only
- <sup>1</sup> P5155274 Wing, Short, Primed, Includes Wing, Dive Plane Asm., Front Splitter, Track Extension, and Fog Light Close Outs, 2003-06 Gen III, 2008-09 Gen IV non-ACR or Without the ARY Package, Roadster Only

## Notes:

· P5155265 and P5155272 are for "Off-Road Use Only". As such they require coilover kit P5155324 or equivalent on any vehicle that will subject to high downforce conditions. The kit is specifically developed to be used with Michelin® Pilot® Sport Cup tires. 2003-2006 cars require an upgraded rear swaybar (05181438AA).

· 2006 and newer vehicles equipped with satellite radio will need to have their antennas relocated for proper reception. For coupes order kit P5155333 and for roadsters order kit P5155334

## VIPER

### EXTERIOR BODY COMPONENTS

#### Wing End Plates (Not Shown)

Rear Wing End Plates are standard on the Viper ACR-X. The new vented design improves wing downforce with drag reduction.

**P5155841** End Plate, Rear Wing, Left Side, Aluminum, 2010 Viper

**P5155840** End Plate, Rear Wing, Right Side, Aluminum, 2010 Viper

#### A. Dive Planes

Upper Dive Planes increase front down force at high speeds. When coupled with an increased rear wing angle to achieve aerodynamic balance, a 100lb increase in down force is achieved. Lower Dive Planes improve down force while enhancing stability and significantly improve grip in high-speed cornering. Recommended for use with the complete ACR aero package.

**P5155839** Dive Planes, Lower, Set, 2010 Viper

**P5155834** Dive Planes, Upper, Set, 2010 Viper

#### Splitter (Not Shown)

Supported by stainless steel tension cables, the splitter is designed to absorb the energy from minor upward deflections. Includes three removable rub strips that provide protection and air resistance.

**P5155838** Splitter Assembly, 2010 Viper

#### Audio and Navigation (Not Shown)

**P5155333** Satellite Radio Antenna Relocation Kit, 2008-09 Viper Coupe

**P5155334** Satellite Radio Antenna Relocation Kit, 2008-09 Viper Roadster



A. P5155834

---

# EIGHT-CYLINDER LATE MODEL VEHICLES

13

PERFORMANCE



27-11-1996-11:29

## EIGHT-CYLINDER LATE MODEL VEHICLES

### ELECTRONIC CONTROL MODULES

#### A. Engine Controller Upgrade

Features optimized fueling and spark settings to take full advantage of the Mopar 5.7L Hemi Performance Camshaft (P5153325) that is included in the 5.7L Hemi Performance Camshaft and Lifter Kit (P5153570).

- <sup>1</sup> P5153331 Powertrain Controller Upgrade, 2005 Charger/ 300/ Magnum, 5.7L
- <sup>1</sup> P5153450 Powertrain Controller Upgrade, 2006 Charger/ 300/ Magnum, 5.7L

**IMPORTANT NOTICE:** This device is not legal for use on pollution-controlled vehicles certified for use on streets or highways. Once this device is installed, use of the vehicle on a street or highway is a violation of the Clean Air Act, potentially subjecting the operator and the installer to civil penalties of up to \$32,500 per vehicle depending on the circumstances.

#### B. Transmission Controller Upgrade

For use with Mopar Performance Torque Converter (P5153726) Upgrade. Features a performance tuned Autostick® calibration with hold-in-gear. This feature will prevent the transmission from upshifting at redline in Autostick® mode for sportier driving.

- <sup>1</sup> P5153332 Controller, Transmission Upgrade, 2004-06 Charger/ 300/ Magnum, 5.7L. Must use with PCM Upgrade (P5153331 or P5153450).
- <sup>1</sup> P5155225 Controller, Transmission Upgrade, A580, 2004-10 Charger/ 300/ Magnum/ Challenger, 5.7L

### AIR SYSTEMS

#### C. Cold Air Intake Systems

Heat up your ride with a steady flow of cold air! This bolt-on system is designed to allow cooler outside air through a directional cone filter and funnel directly into the intake manifold. This kit provides noticeable horsepower and torque gains under varying atmospheric conditions. Kit includes all mounting hardware and a dry-media, washable/reusable dry media filter. Do not oil dry media filters.

- 77060003AC Cold Air Intake System, 2004-10 Charger/300/Magnum/ Challenger, 5.7L
- 77060006AB Cold Air Intake System, 2005-10 Charger/300/Magnum/Challenger, 6.1L
- 77070032 Cold Air Intake System, Dry Media, 2008-10 Challenger/ Magnum/ 300/ Charger, 3.5L
- 77070029 Cold Air Intake System, Long Ram, 2004-10 Charger/ 300/ Magnum/ Challenger, 5.7L/6.1L



A.



B.



C.



## EIGHT-CYLINDER LATE MODEL VEHICLES

### AIR SYSTEMS

#### A. Air Filters- Cold Air Replacement

This filter offers high flow and low restriction, better throttle response and increased filtration and horsepower. Filters are washable and reusable. Do not oil dry media filters.

- 77070015** Air Filter, Cold Air Intake Replacement, Dry Media, Used to Service Kit 77060012AB
- 77070016** Air Filter, Cold Air Intake Replacement, Dry Media, Used to Service Kit 77060022AB
- 77070010** Air Filter, Cold Air Intake Replacement, Dry Media, Used to Service Kits 77060003AB, 77060006AB, 77060010AB, 77060011AB, 77070008
- 77070011** Air Filter, Cold Air Intake Replacement, Dry Media, Used to Service Kits 77060004AB, 77060016, 77060019AB
- 77070012** Air Filter, Cold Air Intake Replacement, Dry Media, Used to Service Kits 77060005AB, 77060009AB, 77070004, 77070006
- 77070038** Air Filter, Cold Air Intake Replacement, Dry Media, Used to Service Kits 77070029 and 77070032

#### B. Air Filters- O.E. Performance Replacement

This high-performance filter is constructed with factory tight seals, engineering-grade polyurethane, and deep pleats made of four plies of oiled cotton gauze and two layers of screen. It offers high flow and low restriction, better throttle response and increased filtration and horsepower. Filter is washable, reusable and comes pre-oiled.

- P4510833** Air Filter, High Flow, O.E. Replacement, 2005-09 5.7L/6.1L Magnum/ 300/ Charger/ Challenger

#### C. Air Filter Service Kit

Servises all Mopar oiled filters that are both washable and reusable.

- P5153376** Air Filter Service Kit, For "Oiled" Air Filters

### EXHAUST SYSTEMS

#### D. Headers

These stainless steel long tube exhaust headers result in an estimated 14-17 horsepower gain. Header and mid pipes only- no catalytic converters. Will not work with factory installed catalytic converters. Stainless steel primaries with formed collector. Race Only.

- <sup>1</sup> **P5155282AB** Headers, 2005-08 Charger/300/Magnum, 5.7L
- <sup>1</sup> **P5155235** Headers, 2005-09 Charger/300, 2008-10 Challenger, 2005-10 Magnum, 6.1L
- <sup>1</sup> **P5155484** Headers, 2009-10 Charger/300/Challenger, 5.7L Eagle
- P5155535** Wire Extension, Oxygen Sensor, Use with P5155484/ P5155282/ P5155235 Headers

A.



B.



C.



D.



Questions? Call the Mopar Direct Connection Techline at 1-888-528-HEMI (4364)

<sup>1</sup> Not legal on pollution-controlled vehicles or vehicles registered for highway use.

## EIGHT-CYLINDER LATE MODEL VEHICLES

### EXHAUST SYSTEMS

#### A. Cat-Back Exhaust System- 6.1L Hemi

Features RSC no-drone technology, with 2.75-inch 304L stainless steel mandrel-bent tubing, stainless (Torca) clamps and polished 4-inch Pro-Series tips. The patented Power-Pulse RSC™ muffler design delivers the throaty exhaust tones that define your Hemi-Powered ride on the open road.

<sup>1</sup> P5153574 Cat-Back Exhaust System, Dual Outlet, 2005-10 Charger/300/Magnum, 6.1L

<sup>1</sup> P5155151 Cat-Back Exhaust System, Dual Outlet, 2008-10 Challenger, 6.1L



A. P5153574

A. P5155151

#### B. Cat-Back Exhaust System- 5.7L Hemi Upgrade

Features RSC no-drone technology, with 2.75-inch 304L stainless steel mandrel-bent tubing, stainless (Torca) clamps and polished 4-inch Pro-Series tips. The patented Power-Pulse RSC™ muffler design delivers the throaty exhaust tones that define your Hemi-Powered ride on the open road.

<sup>1</sup> P5155716 Cat-Back Exhaust System, Dual Rear Exit, 2004-10 Charger/300/ Magnum 5.7L

<sup>1</sup> P5155754 Cat-Back Exhaust System, Dual Rear Exit, 2009-10 Challenger 5.7L with Automatic Transmission

<sup>1</sup> P5155753 Cat-Back Exhaust System, Dual Rear Exit, 2009-10 Challenger 5.7L with Manual Transmission



B. P5155753



B. P5155716

#### C. Cat-Back Exhaust System- 5.7L Hemi

Features T304 stainless steel construction (aircraft quality) with mandrel-bent tubing, stainless band (Torca) clamps and polished tips. Free-flow system provides horsepower and torque gains, improved fuel economy and a deeper tone.

<sup>1</sup> P5155283 Cat-Back Exhaust System, Dual Outlet with Dual Rectangular Tips, 2009-10 Challenger R/T, 5.7L

<sup>1</sup> P4510855 Cat-Back Exhaust System, Dual Outlet, 2.25" Pipe, 2005-10 Charger/300/Magnum, 5.7L



C. P4510855

## EIGHT-CYLINDER LATE MODEL VEHICLES

### EXTERIOR BODY COMPONENTS

#### A. Body Components

Dress up your base level Chrysler 300 and Dodge Magnum with these select chrome components. They are easy to install and will make your vehicle stand out in the crowd.

- 77DUB02000** Mirror, Exterior, Chrome, Heated, 300
- P5155530** Wheel Flare, Package, 300 BUX
- 77DUB04000** Door Handle, Exterior, Chrome, 2004-06 Magnum/300, Set of 4
- 77DUB03000** Mirror, Chrome, 2004-06 Magnum/300, Set of 2
- 77DUB09010** Window Molding, Chrome, Lower, 2004-06 Magnum/300
- 77DUB09000** Window Molding, Chrome, Upper, 2004-06 300
- 77DUB10400** Dress-up Kit, Chrome, Includes 77DUB04000, 77DUB01010 and 77DUB03000, 2004-06 Magnum
- 77DUB10300** Dress-Up Kit, Chrome, Includes 77DUB04000, 77DUB09000, 77DUB09010, 77DUB03000 and 77DUB01010, 2004-06 Magnum
- 77DUB10200** Dress-Up Kit, Chrome, Includes 77DUB04000, 77DUB09000 and 77DUB03000, 2004-06 300
- 77DUB10100** Dress-Up Kit, Chrome, Includes 77DUB04000, 77DUB09000, 77DUB09010 and 77DUB03000, 2004-06 300



A.



A. 77DUB03000



A. 77DUB04000



B.

#### B. Deck Lid Spoiler

Add a little kick to the back end of your beast with this great-looking, one-piece Deck Lid Spoiler. Easy to install, it can be painted to match any vehicle color.

- 77DUB01030** Deck Lid Spoiler, 2004-09 Chrysler 300
- 77DUB01040** Spoiler, Backlight, DUB Edition, With Integrated Navigation Antenna Cover

#### C. Two-Piece Grille Assembly

Bring the Dodge Magnum R/T-inspired look to your base or SXT Magnum with this aggressive grille assembly.

- 77DUB01010** Chrome Grille with Black Accents, 2004-06 Magnum (Except R/T), 5.7L



C.



D. Chrysler 300

#### D. Grille Assembly, Wire Mesh, Stainless

This chromed, polished stainless steel grille sets the restyling standard for the popular Chrysler 300.

- 77DUB01020** Grille, Chrome, Wire Mesh, with Chrysler Winged Badge, 2005-06 Chrysler 300

#### E. Wire Mesh Grille Insert

Inexpensively update the look of your Magnum with this stainless steel Wire Mesh Grille Insert kit.

- 77DUB01022** Grille, Chrome, Wire Mesh, 2005-06 Charger
- 77DUB01021** Grille, Chrome, Wire Mesh, 2005-06 Magnum



E. Magnum



E. Charger

## EIGHT-CYLINDER LATE MODEL VEHICLES

### INTERIOR

#### A. Interior Vehicle Components

- 77DUB07010** Floor Mats, with DUB Logo, AWD Magnum/300
- 77DUB07000** Floor Mats, with DUB Logo, RWD Magnum/300
- 77DUB08000** Sill Plate, Illuminated with DUB Logo, Magnum/300

#### B. Shifters

- P5155277 Hurst Competition/Plus 2 shifter for the 6-speed challengers. Bolt on classic chrome plated stick and white knob. Shift throw reduced for quicker shifts. CNC machined stainless steel stick assembly, aluminum carrier arm and nylon lined spherical pivot bearing.

- P5155458 Same as P5155277 except Hurst Pistol Grip Shift lever which is offered exclusively through Mopar! Give your Challenger the muscle car look and feel but with modern carbon fiber finish it deserves with these brand-new, factory reissued pistol grip shift levers from Hurst.

- P5155284AB Features an easy bolt in Shifter Lever with an embossed billet aluminum Knob. 1" shorter than production for a 4.5:1 lever ratio. Allows more precise shifts without increasing production level NVH (noise/vibration/harshness). Will accommodate any 3/8-16 thread shifter knob.

- P5155277** Shifter, Short Throw Asm., Hurst, Includes White Knob, 2009-10 Challenger (LC), MTX
- P5155458** Shifter, Short Throw Asm., Hurst, Pistol Grip, 2009-10 Challenger (LC), MTX
- P5155284AB** Shifter, Lever and Knob, 2009-10 Challenger (LC), MTX
- P5155704** Shift Knob, Leather Wrapped, Use with P5155284AB or P5155277
- P5155705** Shift Knob, Carbon Fiber, Use with P5155284AB or P5155277.

### SUSPENSION UPGRADES AND COMPONENTS

#### C. Stage 1 Performance Springs

These performance springs are for 300C and Magnum R/T owners who desire a sporty yet comfortable ride. They reduce ride height 1.0" for that low, custom look. The high-tensile spring material ensures durability and heightens spring performance without bind. These factory-produced lowering springs were designed utilizing Chrysler engineering specs to achieve optimal performance. Set of four.

- P4510854** Lowering Springs, Stage 1 Performance, 2005-10, 5.7L Charger/ 300, RWD, Vehicle Set
- P5153327** Lowering Springs, Stage 1 Performance, 2005-10, 5.7L Magnum, RWD, Vehicle Set
- P5155436** Lowering Springs, Stage I Performance, 2008-10 Challenger, Vehicle Set

Note: When fitting Lowering Springs (P4510854) on 2006 and newer model year 300C, Charger RT, Magnum RT, and Daytona vehicles equipped with Sachs Nivomat self-leveling rear shock absorbers, a rear shock change is required for proper appearance. The 2005 model rear non self-leveling shocks (or equivalent) are required to achieve proper ride height. Failure to replace the original equipment, self-leveling rear shocks on these vehicles as described will result in a rear ride height that is too high.



A. 77DUB07000



A. 77DUB08000



B. P5155277



B. P5155458



B. P5155284AB



B. P5155704



B. P5155705



C.



A. P4510841



A. P5155152

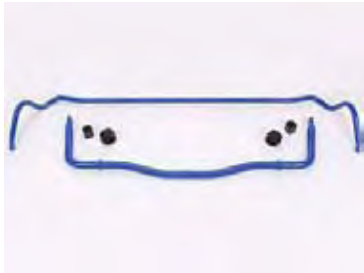

B. P4510842



C. P5155002



D. P5155645



E. P5155435



F.

## EIGHT-CYLINDER LATE MODEL VEHICLES

### SUSPENSION UPGRADES AND COMPONENTS

#### A. Stage 2 Coilover Suspension Kit

Allows up to 1.625" ride height drop.

- P4510841** Coilover Suspension Kit, Stage 2 Performance, 2005-10 Magnum/300/Charger, 5.7L/6.1L
- P5155152** Coilover Suspension Kit, Stage 2 Performance, 2008-10 Challenger, 5.7L/6.1L

#### B. Anti Sway Bar Kit

Increase steering response and handling. These bars are recommended for use with Stage 2 Coilover Suspension Kit (P4510841).

- P5155239** Anti Sway Bar, Stage 1, Front: 32mm, Rear: 19mm, 2008-10 Challenger, 5.7L/6.1L
- P4510842** Anti Sway Bar, Stage 1, Front: 32mm, Rear: 22mm, 2005-10 Magnum/300/Charger, 5.7L/6.1L

#### C. Strut Tower Brace

- P5155002** Strut Tower Brace, Front, 2005-10 Charger/300/Magnum/Challenger, 5.7L/6.1L
- P5155751** Strut Tower Brace, Rear, 2005-11 Charger/300/Magnum/Challenger, 5.7L/6.1L

#### D. Shocks

Developed from the 2011 Challenger SRT8, the "pursuit" package has been adapted as an upgrade to the current 5.7L production shock package. Not for use on SRT vehicles.

- P5155679** Shock Package, Pursuit, 2005-10 Charger/ 300/ Magnum, 2008-10 Challenger, 5.7L
- P5155645** Shock Package, Pursuit, 2011 Charger/ 300/ Challenger, 5.7L

#### E. Suspension Upgrade, SE and R/T

Upgrade you current SE or R/T with these unique SRT suspension components. This take-a-way package includes shocks, springs, isolators, and rear strut mounts.

- P5155435** Suspension Upgrade, SRT to SE and R/T. Includes Shocks, Springs, and Isolators, 2008-10 Charger/ 300/ Challenger, 5.7L

### DRIVETRAIN AND REAR AXLE COMPONENTS

#### F. Quaife Traction Differential

Improves your vehicle's launch time and cornering ability. This complete kit includes new carrier bearings, axle seals, preload shims, complete instructions, and ring gear bolts.

- <sup>1</sup> **P5153693** Traction Differential, Quaife, 2005-09 Magnum/300/Charger, 5.7L

## EIGHT-CYLINDER LATE MODEL VEHICLES

### DRIVETRAIN AND REAR AXLE COMPONENTS

#### Gear Upgrade- 5th. (Not Shown)

This fifth gear upgrade kit is intended to give a closer gear ratio for fifth gear, giving the car a sportier feel while still maintaining the fuel economy of sixth gear. This kit changes the fifth gear ratio from 0.74:1 to 0.796:1.

**P5155799** Gear Upgrade, 5th. Gear, Manual Transmissions, 2009-11  
Challenger , 2008-09 Viper

# FOUR-CYLINDER & SIX CYLINDER LATE MODEL VEHICLES

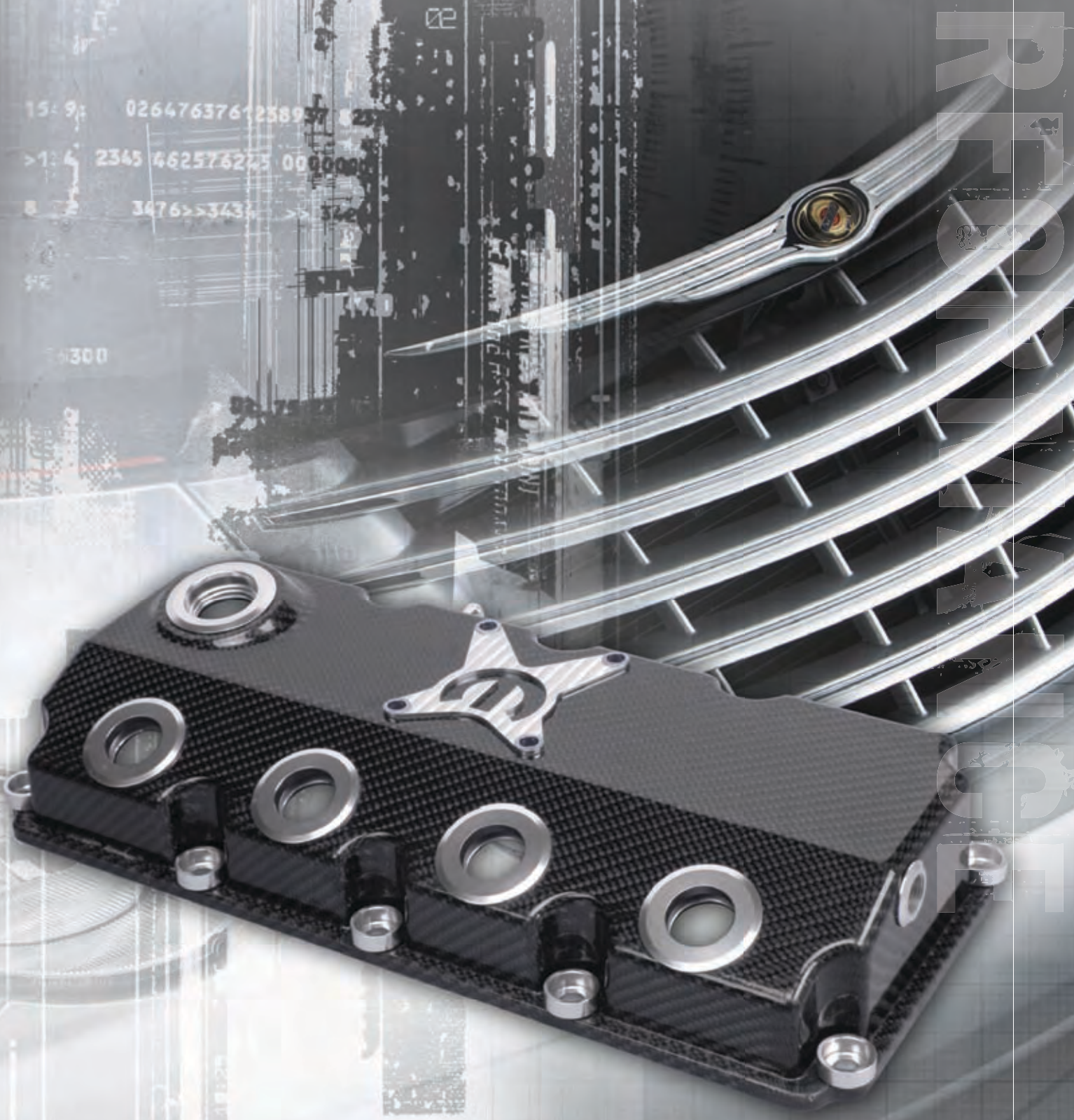

15: 9: 02647637612389 57 525

>1: 4 2345 462576275 0000000

8: 2 3476>>3436 >> 342

300

PERFORMANCE

27-11-1996 11:25

## FOUR- AND SIX-CYLINDER LATE MODEL VEHICLES

### TURBO SERVICE PARTS

#### A. Blow-off Valves

Maximizes the function of your vehicle's turbo system by venting excess hot compressed air into the atmosphere, thereby reducing your intake air temperature. This kit adds a vent to the stock blow-off valve and creates a unique turbo sound.

- <sup>1</sup> P4510548 Blow-Off Valve Conversion Kit, Anodized Blue, 2003-05 Neon SRT4, 2003-09 PT Turbo, 2008-09 Caliber SRT4
- <sup>1</sup> P4510868 Blow-Off Valve Diaphragm, Stage 2 and 3R

#### B. Fuel Components

- <sup>1</sup> P4510554 Fuel Pump, 75 psi Regulated, 2003-05 Stage 3R
- <sup>1</sup> P5249511 Fuel Pump, Super 60, Electric, 2.2L/2.5L
- <sup>1</sup> P4510063 Fuel Rail, Demand Regulated, Stage 3R
- <sup>1</sup> 04852396AB Washers, Fuel Line, Copper, All Turbos, Package of 6

#### C. Exhaust Gasket

- <sup>1</sup> 04884447AA Gasket, Exhaust Header, All Turbos

#### D. Fuel Injectors

- <sup>1</sup> P4510529 Fuel Injector, +30%, 2003-05 Stage 2/3R, Sold Individually
- <sup>1</sup> P4529495 Fuel Injector, High Flow, Turbo I and II, Set of Four
- <sup>1</sup> P4532586AB Fuel Injector, Super 60, 40%+, 2.2L/2.5L, Sold Individually
- <sup>1</sup> P4452803 Fuel Injectors, EFI, 1984-89 Turbo I, Set of Four
- <sup>1</sup> P4452804 Fuel Injectors, EFI, 1990-91 2.5L Turbo I, 1987-91 Turbo II/III/IV, Set of Four

#### E. Turbo Toys

- <sup>1</sup> P4510922 Sprayer Brackets, Turbo Toys, Set of Two
- <sup>1</sup> P4510632 Sprayer Pump, Turbo Toys
- <sup>1</sup> P4510626 Water Filter, Inline, Turbo Toys
- <sup>1</sup> P4510923 Water Jets, Set of Four, Turbo Toys
- <sup>1</sup> P4510862 Wire Harness, Blue LED, Turbo Toys
- <sup>1</sup> P4510863 Wire Harness, Red LED, Turbo Toys
- <sup>1</sup> P4510861 Wiring Harness Terminals, Set of 10 (Turbo Toys)

#### F. Turbos

- <sup>1</sup> P4510864 Turbo Cartridge, Inconel Center Section, Stage 3R
- <sup>1</sup> P4510865 Turbo Cartridge, TIAI Center Section, Stage 3R

#### G. Compressor Cover Kit

- <sup>1</sup> P4510867 Cover, Compressor, Includes Cover, Surge Bypass Valve, and Surge Valve Bolts, Stage 3R

#### H. Manifold Kit

- <sup>1</sup> P5007922 Compressor and Exhaust Manifold, Service part for Stage 3R Turbo kits P5007864, P4510338, and P4510339
- <sup>1</sup> P4510869 Manifold Kit, Turbo Exhaust Elbow (P4510278), Manifold (P4510877), Elbow Bolts (5), Stage 3R



A.



B. P4510554



C.



D. P4510529



E. P4510632



E.



E.



E. P4510923



E. P4510922



F.



G.



H.



FOUR- AND SIX-CYLINDER LATE MODEL VEHICLES

TURBO SERVICE PARTS

A. Wastegate Actuators

<sup>1</sup> P4510596 Wastegate Actuator, P420, Stage 3R

B. Hardware Kit

<sup>1</sup> P4510866 Turbo Hardware Kit, TD05HR, Includes Clamp, Snap Ring, Actuator and Elbow Bolts, Stage 3R



A.



B.

CAMSHAFTS, LIFTERS, AND HARDWARE

C. Camshafts, UGL

These camshafts are developed for power while maintaining reliability and idle quality. Camshaft package includes camshaft, front seal and camshaft lube.

<sup>1</sup> P4529314 Camshaft, Hydraulic, 240/248 Duration, .460" Lift, 2.2L/2.5L Turbo Applications



C.



D.

D. Camshafts, High Performance, Hydraulic

<sup>1</sup> P5007030 Camshaft, 6 HP Increase, 2 HP with 2001 H.O. Engine, 232/260 Duration, .279/.272 Lift, 1995-02 Neon SOHC

<sup>1</sup> P5155537 Camshaft, Hydraulic, 0.425 / 0.425 Lift, 252 / 252 Adv. Duration

<sup>1</sup> P5155538 Camshaft, Hydraulic, 0.44 / 0.44 Lift, 260 / 260 Adv. Duration

<sup>1</sup> P4452767 Camshaft, Hydraulic, 0.460/0.460 Lift, 240/248 Duration, .460" Lift, 2.2L/2.5L Non-Turbo



E.

E. Camshafts, High Performance, Mechanical

<sup>1</sup> P5155539 Camshaft, Mechanical, 0.435 / 0.435 Lift, 252 / 252 Adv. Duration

<sup>1</sup> P5155540 Camshaft, Mechanical, 0.44 / 0.44 Lift, 264 / 264 Adv. Duration

See chart for additional information.

CHRYSLER / DODGE

6-CYLINDER HIGH PERFORMANCE CAMSHAFTS

Mopar Part Number	Valve Setting		RPM Operating Range	DURATION				VALVE LIFT		LOBE SEP ANGLE	Notes
	Intake	Exhaust		ADVERTISED		@ .050"		W/ 1.6 ROCKER			
				IN.	EX.	IN.	EX.	IN.	EX.		
<b>HIGH ENERGY™ Hydraulic Flat Tappet Camshafts</b>											
P5155537	Hyd.	Hyd.	800 to 4500	252	252	206	206	.425	.425	110°	Good stock replacement for mileage and power increase. Low rpm torque. Smooth idle.
P5155538	Hyd.	Hyd.	1200 to 5000	260	260	212	212	.440	.440	110°	Great power in mid-range rpm. Good choice for trucks and tow vehicles. Smooth idle.
<b>HIGH ENERGY™ Mechanical Flat Tappet Camshafts</b>											
P5155539	.010	.012	800 to 4500	252	252	215	215	.435	.435	110°	Great power and mileage increases. Smooth idle.
P5155540	.010	.012	1200 to 5000	264	264	220	220	.440	.440	110°	Excellent choice for trucks and towing. Good power in low-mid rpm. Smooth idle.

Questions? Call the Mopar Direct Connection Techline at 1-888-528-HEMI (4364)

<sup>1</sup> Not legal on pollution-controlled vehicles or vehicles registered for highway use.

## FOUR- AND SIX-CYLINDER LATE MODEL VEHICLES

### CAMSHAFTS, LIFTERS, AND HARDWARE

#### A. Hydraulic Lash Adjusters

Use these for improved hydraulic lash control. Resistant to aeration. Sold in sets of four (two sets required per engine). 2.4L engines found in the following vehicles: Caravan, Town&Country, Stratus, Stratus Coupe, Sebring Sedan, Sebring Coupe, Sebring Convertible, Breeze, Cirrus, and PT Cruiser.

<sup>1</sup> P5007440 Lash Adjusters, Hydraulic, 1995–99 Neon DOHC, 2.4L DOHC Engines



A.



B. P4349650

#### B. Offset Camshaft Key

<sup>1</sup> P4349650 Camshaft Keys, Offset, 2V SOHC

### ROCKER ARMS, SHAFTS, SUPPORTS, AND HARDWARE

#### C. Rocker Arms and Hardware

<sup>1</sup> P4349147 Rocker Arms, Heavy Duty, 2.2L/2.5L SOHC with Non-Roller Cams



C.



D. P4452005

### CYLINDER HEADS, GASKETS, AND HARDWARE

#### D. Cylinder Head Gaskets

P4452005 Gasket, Cylinder Head, Composite Material, TBI, Turbo I

P4452006 Gasket, Cylinder Head, Cross-Drilled, Turbo II

P4120868 Gasket, Engine Teardown, 2.2L (Except Turbo II)

#### E. Cylinder Head Hardware

P4349736 Bolt Set, Cylinder Head, 11 mm, 1985 and Later OHC, 2.2L/2.5L

P4120456 Washer, Hardened, 3/8"

#### F. Engine Teardown Gaskets

P4120868 Gasket, Engine Teardown, 2.2L (Except Turbo II)



E.



F.

### ENGINE STRUTS AND MOUNTS

#### G. Engine Mounts

P5007028 Bobble Strut, Engine, 1995–99 Neon DOHC/SOHC

P5007027 Engine Mounts, 1995–99 Neon DOHC/SOHC

P4286766 Engine Mounts, FWD, Front, 2.2L/2.5L

P4286765 Engine Mounts, FWD, Right Side all 2.2L/2.5L, Left Side all 1981–83 2.2L



G.



G.

### PISTONS AND CONNECTING RODS

#### H. Pistons

Same piston as production, but .020" oversize.

<sup>1</sup> P5007385 Piston, Oversized, 1995-99 Neon SOHC Engine



H.

## FOUR- AND SIX-CYLINDER LATE MODEL VEHICLES

### INTAKE MANIFOLDS, HARDWARE, AND GASKETS

#### A. EGR Block-Off Plate Kit

Lightweight, 6061-T6 anodized aluminum Block-Off Plate for racing purposes only. Includes head and manifold plates with gaskets.

<sup>1</sup> P5007276 EGR Block-Off Plate, 1995–99 Neon SOHC/DOHC

### VALVE TRAIN HARDWARE AND COMPONENTS

#### B. Valve Keepers

These 2.2L/2.5L Valve Keepers are made from hardened material. They feature an 8 mm stem diameter and 7° valve angle, and can be used for restoration or performance applications. Different groove styles are available to meet your application requirements. Sold as cylinder head sets of 8.

<sup>1</sup> P4452031 Valve Keepers, Single Groove, 2.2L/2.5L SOHC

<sup>1</sup> P4452030 Valve Keepers, Triple Groove, 2.2L/2.5L SOHC

#### C. Valve Seals

<sup>1</sup> P4349121 Valve Seals, 8 mm, 2.2L/2.5L SOHC

#### D. Valve Springs

High-pressure Valve Springs can be used on exhaust and intake valves for all high-performance applications. They feature a shorter, fully-compressed height and allow for increased valve lift. Springs maintain spring load at higher rpms. A must for high-performance camshafts. The retainers listed are the basic recommendation. Check the actual retainer listing for other options such as added installed height, materials and lock size. Sold individually.

<sup>1</sup> P4876636 Valve Spring, 1995–99 Neon DOHC

<sup>1</sup> P5249846 Valve Spring, Neon SOHC

<sup>1</sup> P4876061 Valve Spring, Race, 2.2L

#### Degree Wheel Adapter (Not Shown)

Use the Mopar aluminum Degree Wheel for centering camshafts. 1-180-0 degrees. Step-by-step installation instructions are printed conveniently on the reverse side.

P4286776

#### E. Valve Seal Inserts

<sup>1</sup> P4349125 Valve Seat Insert, Aluminum, Intake, 44 mm, 2.2L

#### F. Valve Spring Retainers

P4286574 Retainer, Valve Spring, Aluminum, 2.2L

P4452032 Retainer, Valve Spring, Chrome Moly, 7 Degree, 8mm Stem Diameter, Single, 2.2L/2.5L SOHC and 5.2L/5.9L Magnum Engines

#### G. Valves

<sup>1</sup> P5007508 Valve, Exhaust, 29.30 mm Diameter, Neon SOHC

<sup>1</sup> P5007507 Valve, Intake, 34.00 mm Diameter, Neon SOHC

<sup>1</sup> P4529824 Valve, Intake, 40 mm Diameter, One Square Groove, Back-Cut, 1986–up 2.2L/2.5L SOHC



A.



B.



C.



D.



D.



E.



F.



G.

Questions? Call the Mopar Direct Connection Techline at 1-888-528-HEMI (4364)

<sup>1</sup> Not legal on pollution-controlled vehicles or vehicles registered for highway use.

CHRYSLER / DODGE

## FOUR- AND SIX-CYLINDER LATE MODEL VEHICLES

### VALVE COVERS AND HARDWARE

#### A. Valve Cover, Carbon Fiber

Add even more excitement under your hood with a Carbon Fiber Valve Cover. Mopar's injection-molded carbon fiber valve cover offers great sealing performance using stock seal and anodized 6061 aluminum fittings. T-will woven materials give the valve cover a stunning carbon fiber look. This is the lightest valve cover that can be made without sacrificing the structural integrity necessary for race cars and high-performance street machines.

**P4510538** Valve Cover, Carbon Fiber, 2003–05 Neon SRT4, 2003–09 PT Turbo

Note: Carbon Fiber Valve Cover P4510538 is not compatible with Strut Tower Braces P4510543 and P4510874.



### SUSPENSION UPGRADES AND COMPONENTS

#### B. Stage 3 Coilover Suspension Kit

The Mopar Stage 3 Coilover Suspension Kit features new INOX stainless steel technology exclusive to Mopar and KW Suspensions. After 418 hours of testing (salt water spray), INOX Coilover Suspension Struts constructed of stainless steel were clearly superior to the galvanized versions in terms of corrosive resistance, and they were still functioning perfectly after testing. The Mopar Stage 3 Coilover Suspension Kit includes all the features of the Stage 2 Kit. In addition, the Stage 3 Kit allows drivers to adjust the damper setting of the suspension system for the ultimate in personalization. The adjustable rebound damper gives drivers the ability to adjust the vehicle's pitch and roll to their driving preferences and needs, from the street to the track. The Stage 3 Kit is height adjustable and rebound adjustable from 20% under to 50% over Stage 2 settings. Rebound adjustment takes place via an adjustment screw at the end of the piston rod, and primarily affects the low and midrange rebound dampening. Complete vehicle set.

##### Features:

- External adjustable rebound damper
- Stock height and down lowering range
- Easy-adjust stainless steel-impregnated composite perches
- High-quality, high-tensile racing springs
- Special ventilation and sealing system
- Hardened chromium-plated piston rods
- Pistons with V-shaped T.e. on seals
- Strut housings in INOX-line stainless steel
- In. nitely adjustable within adjustment parameters
- Shortened struts for increased travel
- Trapezoidal adjustment threads for simple height adjustment
- Elastomer bump stops with integrated dust boot protection

<sup>1</sup> **P4510587** Coilover Suspension Kit, Stage 3, 2000–05 Neon

<sup>1</sup> **P4510586** Coilover Suspension Kit, Stage 3, 2003–05 SRT4

<sup>1</sup> **P4510628** Coilover Suspension Kit, Stage 3, 2003–06 PT Turbo

<sup>1</sup> **P5153672** Coilover Suspension Kit, Stage 3, 2006–10 Caliber

<sup>1</sup> **P5153838** Coilover Suspension Kit, Stage 3, 2008–09 Caliber SRT4 Track Suspension

A.



B.



C.

#### C. Stage 3R Damper Kit

<sup>1</sup> **P4510825** Damper, Stage 3R, Race Only, Double-Adjustable Threaded Strut Kit, 2003–05 SRT4

## SUSPENSION UPGRADES AND COMPONENTS

### A. Stage 3R Race and Helper Springs

Designed to work with the valving and setup of the Stage 3R Coilover Suspension System. Constructed of a new lightweight alloy, these high-tensile race springs provide a lighter weight solution, along with increased travel before spring bind, than standard linear springs. Depending on your use, different rates can be combined with the valving to produce various handling characteristics. Can be purchased separately in various rates. Sold in pairs only.



- <sup>1</sup> P4510817 Helper Spring, Front, 2003–05 Neon SRT4
- <sup>1</sup> P4510822 Helper Spring, Rear, 2003–05 Neon SRT4
- <sup>1</sup> P4510823 Springs, High-Tensile, Stage 3R, 35 N-M (250 MM), 2003-05 Neon SRT4
- <sup>1</sup> P4510836 Springs, High-Tensile, Stage 3R, 45 N-M (250 MM), 2003–05 Neon SRT4
- <sup>1</sup> P4510818 Springs, High-Tensile, Stage 3R, 50 N-M (250 MM), 2003–05 Neon SRT4
- <sup>1</sup> P4510819 Springs, High-Tensile, Stage 3R, 60 N-M (200 MM), 2003–05 Neon SRT4
- <sup>1</sup> P4510837 Springs, High-Tensile, Stage 3R, 70 N-M (200 MM), 2003–05 Neon SRT4
- <sup>1</sup> P4510821 Springs, High-Tensile, Stage 3R, 90 N-M (170 MM), 2003–05 Neon SRT4

### B. Stage 2 Coilover Suspension Kit

Get ready for a whole new level of performance! The Mopar Stage 2 Coilover Suspension Kit will provide your vehicle with better handling and ride characteristics than any other aftermarket suspension system available today. It features new INOX stainless steel technology exclusive to Mopar and KW Suspensions. After 418 hours of testing (salt water spray), INOX Coilover Suspension Struts constructed of stainless steel were clearly superior to the galvanized versions in terms of corrosive resistance, and they were still functioning perfectly after testing. The Mopar Stage 2 Coilover Suspension Kit utilizes cutting edge technology born on the track and raised on the street. It allows you to lower your vehicle within a specified range using adjustable spring perches to suit your driving needs. It is height-adjustable from 0 mm to 30 mm lower than factory, and includes fixed-valve dampers. Complete vehicle set.

#### Features:

- Easy-adjust stainless steel impregnated composite perches
- Stock height and down lowering range
- High-quality, high-tensile racing springs
- Special ventilation and sealing system
- Hardened chromium-plated piston rods
- Pistons with V-shaped T.e. on seals
- Strut and shock housings in INOX-line stainless steel
- In. nitely adjustable within adjustment parameters
- Shortened struts for increased travel
- Trapezoidal adjustment threads for simple height adjustment
- Elastomer bump stops with integrated dust boot protection

- <sup>1</sup> P4510447 Coilover Suspension Kit, Stage 2, 2003–05 Neon SRT4

A.



B.

Questions? Call the Mopar Direct Connection Techline at 1-888-528-HEMI (4364)

<sup>1</sup> Not legal on pollution-controlled vehicles or vehicles registered for highway use.

## FOUR- AND SIX-CYLINDER LATE MODEL VEHICLES

### SUSPENSION UPGRADES AND COMPONENTS

#### A. Stage 1 Anti-Sway Bar Kit

Made from high-quality bar material that ensures durability and heightens performance, these Performance Anti-Sway Bars improve ride and handling by virtually eliminating body roll, helping to keep all four tires firmly on the pavement. Customers who do not currently have a rear sway bar must also purchase the Sway Bar Installation Kit (P4510839).

- <sup>1</sup> P4510457 Anti-Sway Bar, Stage 1, Front and Rear, 2000–05 Neon
- <sup>1</sup> P4510261 Anti-Sway Bar, Stage 1, Front: 25.4 mm, Rear: 19 mm, 2001–09 PT Cruiser Non-Turbo
- <sup>1</sup> P5153749 Anti-Sway Bar, Stage 1, Front: 25mm, Rear: 19mm, 3 Position Adjustable, 2007–08 FWD Caliber
- <sup>1</sup> P5153837 Anti-Sway Bar, Stage 1, Front: 25mm, Rear: 19mm, 3 Position Adjustable, 2007–09 AWD Caliber
- <sup>1</sup> P4510454 Anti-Sway Bar, Stage 1, Front: 26 mm, Rear: 19 mm, 3-Position Adjustable, 2003–05 Neon SRT4
- <sup>1</sup> P4510455 Anti-Sway Bar, Stage 1, Front: 27 mm, Rear: 19 mm, 2003–09 PT Turbo
- <sup>1</sup> P4510839 Hardware Kit, Anti-Sway Bar Installation, Required to Mount Rear Anti-Sway Bar on Vehicles Without Factory Anti-Sway Bar, 2001–09 PT Cruiser



#### B. Stage 1 Performance Springs

Made of high-tensile spring material to ensure durability and heighten spring performance without bind. Also provides a 25 mm drop from the stock ride height. Vehicle set.

- <sup>1</sup> P4510459 Springs, Performance, Stage 1, 20 mm Front Drop, 18 mm Rear Drop, 2001–09 PT Cruiser Non-Turbo
- <sup>1</sup> P4510460 Springs, Performance, Stage 1, 2000–05 Neon
- <sup>1</sup> P4510458 Springs, Performance, Stage 1, 2003–05 Neon SRT4
- <sup>1</sup> P5153834 Springs, Performance, Stage 1, 2006–10 Caliber (PM) AWD 1.8L/2.4L
- <sup>1</sup> P4510262 Springs, Performance, Stage 1, 22 mm Front Drop, 18 mm Rear Drop, 2003–09 PT Turbo
- <sup>1</sup> P5153251 Springs, Performance, Stage I, 2007–09 FWD Caliber, Non-Turbo

A.



B.

## FOUR- AND SIX-CYLINDER LATE MODEL VEHICLES

### SUSPENSION UPGRADES AND COMPONENTS

#### A. Strut Tower Brace

Made of heavy gauge powder coated steel, this MIG welded Mopar Performance Strut Tower Brace reduces body flex in the front end, improving handling and drivability. Easy bolt-on installation.

- <sup>1</sup> P5153985 Strut Tower Brace, Front, Steel, 2007-09 Avenger/Sebring
- <sup>1</sup> P5153306 Strut Tower Brace, Front, Steel, 2000-03 Neon 2.0L
- <sup>1</sup> P4510543 Strut Tower Brace, Front, Steel, 2003-05 Neon SRT4
- <sup>1</sup> P4510874 Strut Tower Brace, Front, Titanium, 2003-05 Neon SRT4
- <sup>1</sup> P4510876 Strut Tower Brace, Rear, Steel, 2003-05 Neon SRT4
- <sup>1</sup> P4510875 Strut Tower Brace, Rear, Titanium, 2003-05 Neon SRT4
- <sup>1</sup> P5153565 Strut Tower Brace, Front, Steel, 2007-09 Compass/Patriot/Caliber, Non-Turbo
- <sup>1</sup> P5155033 Strut Tower Brace, Front, Steel, 2008 Caliber SRT4

Front braces P4510543 and P4510874 are not compatible with Carbon Fiber Valve Cover P4510538.

#### B. Control Arm

- <sup>1</sup> P4510870 Control Arm, Rear, Adjustable, 2000-05 2.0L/2.4L, Neon, SRT4, Set

#### C. Struts

Based on Rally and Touring Car Technology, these Performance Struts are the same as used on the production 2001 Dodge Neon ACR. They feature inverted tube technology for stiffer construction, reduced lateral and longitudinal deflection, and improved durability and performance. Easily adjustable in compression and rebound. Sold individually.

- <sup>1</sup> P5007389 Strut, Front (R/L), ACR Performance, 2000-01 Neon
- <sup>1</sup> P4876812 Strut, Front, 1995-99 Neon

#### D. Camber Plates

- <sup>1</sup> P4510828 Camber Plates, Front, Stage 2/3/3R Suspensions, 2001-05 Neon and 2003-05 Neon SRT4,
- <sup>1</sup> P4510827 Camber Plates, Rear, Stage 2/3/3R suspensions, 2001-05 Neon

#### E. Rear Tension Strut Kit

Rear Tension Struts feature a high-durometer bushing material designed for heavy-duty and competition use. The revised design results in improved toe stability (reduced bump-steer), which virtually eliminates rear wheel hop under heavy braking. Provides more positive suspension control for improved driver feedback and dynamic stability.

- <sup>1</sup> P4510826 Strut Kit, Rear Tension, Left and Right, 2003-05 Neon SRT4, 2000-05 Neon

#### F. Strut Adjuster Knob

Use to adjust both production and Mopar Neon ACR struts. Same as provided in Neon ACR glove box.

- <sup>1</sup> P5007269 Knob, Strut Adjuster, 1995-99 Neon ACR



A. P4510543



A. P4510875



B.



C.



D.



E.



F.

Questions? Call the Mopar Direct Connection Techline at 1-888-528-HEMI (4364)

<sup>1</sup> Not legal on pollution-controlled vehicles or vehicles registered for highway use.

## FOUR- AND SIX-CYLINDER LATE MODEL VEHICLES

### SUSPENSION UPGRADES AND COMPONENTS

#### A. ACR Power Steering Rack

Complete kit to upgrade existing power steering (18:1 ratio) to faster (16:1 ratio) ACR. Uses existing pump, belt, crank pulley, hoses and mounting hardware. Includes tie rod ends and tie rod heat shields.

<sup>1</sup> P5007308 Power Steering Rack, ACR, 1995-99 Neon

### IGNITION AND ELECTRONICS

#### B. Ignition Wire Set

<sup>1</sup> P4876546 Wire Set, Spark Plug, 1995 Neon SOHC

<sup>1</sup> P4876511 Wire Set, Spark Plug, 7.5 mm, Pre-Cut, Neon/ PT Cruiser and 2.4L DOHC Stratus



A.



B.



## IGNITION AND ELECTRONICS

### A. Engine Controllers



A.

All other engine controllers in this section are race computers and are programmed to deliver high performance from turbocharged 2.2L or 2.5L Chrysler powered vehicles. Special Stage II computers for the 1986-87 Shelby GLHS and CSX models are also included. The Turbo I computers feature full-time boost levels up to 11 psi, with a corresponding faster rise time for the boost curve, plus revised fuel and spark schedules. Turbo II computers feature boost levels up to 13 psi to take advantage of the cooler inlet charge, in addition to the features included in the Turbo I computers. The Stage II computers are calibrated for a WOT (Wide Open Throttle) boost level of 14 psi. Do not attempt to use these computers on any vehicle except those produced by Shelby Automobiles.

- <sup>1</sup> P5007034 Engine Controller, Manual Transmission, 1995 Neon DOHC
- <sup>1</sup> P5007033 Engine Controller, Manual Transmission, 1995 Neon SOHC
- <sup>1</sup> P5007036 Engine Controller, Manual Transmission, 1996 Neon DOHC
- <sup>1</sup> P5007035 Engine Controller, Manual Transmission, 1996 Neon SOHC
- <sup>1</sup> P5007038 Engine Controller, Manual Transmission, 1997-99 Neon DOHC
- <sup>1</sup> P5007037 Engine Controller, Manual Transmission, 1997-99 Neon SOHC
- <sup>1</sup> P4529871 Engine Controller, Stage I, 1985 2.2L and 1987 Shelby Charger
- <sup>1</sup> P4529873 Engine Controller, Stage I, 1987 2.2L, Except Shelby Charger
- <sup>1</sup> P5249671 Engine Controller, Stage II, Carb. E.O. #D-265, 1987 Shelby CXS
- <sup>1</sup> P5249528 Engine Controller, Super 60, 2.2L

#### NOTICE:

These controllers are not legal for use on pollution-controlled vehicles certified for use on streets or highways. Once this controller is installed, use of the vehicle on a street or highway is a violation of the Clean Air Act, potentially subjecting the operator and the installer to civil penalties of up to \$32,500 per vehicle depending on the circumstances.

Mopar engine controllers P5007033 - P5007038 are emissions exempt (D-265-18) in California, Massachusetts, and New York, and are a direct replacement for the production units. They will provide horsepower and torque increases without affecting drivability. Requires the use of premium fuel. Manual transmission vehicles only.

## FOUR- AND SIX-CYLINDER LATE MODEL VEHICLES

### AIR SYSTEMS

#### A. Cold Air Intake Systems

What's so great about cold air intakes? Cold air is much denser than hot, humid air and holds more oxygen. More oxygen going into an engine equals more combustion, thus more power. The Mopar Cold Air Intake System increases airflow by as much as 20%, boosting torque up to ten lbs., and power by nearly ten horsepower. All of this while improving fuel economy (one to two mpg depending on driving style). Air filters are high-flow and low-restriction, offer better throttle response and increased filtration and horsepower. Filters are made of a new dry media material which is washable and reusable. Do not oil dry media filters.

- 77070002 Clod Air Intake System, Dry Media, 2007-09 Nitro, 4.0L
- 77060022AB Cold Air Intake System, Dry Media, 2000-05 Neon 2.0L SOHC
- 77060004AB Cold Air Intake System, Dry Media, 2003-05 Neon, SRT4
- 77060019AB Cold Air Intake System, Dry Media, 2005-09 300, 2006-09 Charger, 2005-08 Magnum, 2009 Challenger, 3.5L
- 77060012AB Cold Air Intake System, Dry Media, 2007-09 Caliber/Compass/Patriot, 1.8L/2.0L/2.4L, Non-Turbo
- 77060080 Cold Air Intake System, Dry Media, 2007-09 Nitro, 3.7L
- 77070005 Cold Air Intake System, Dry Media, 2007-2009 Avenger/Sebring, 3.5L
- 77070008 Cold Air Intake System, Dry Media, 2008-09 Caliber SRT4

#### B. Air Filters- Cold Air Replacement

This filter offers high flow and low restriction, better throttle response and increased filtration and horsepower. Filters are washable and reusable. Do not oil dry media filters.

- 77070015 Air Filter, Cold Air Intake Replacement, Dry Media, Used to Service Kit 77060012AB
- 77070016 Air Filter, Cold Air Intake Replacement, Dry Media, Used to Service Kit 77060022AB
- 77070019 Air Filter, Cold Air Intake Replacement, Dry Media, Used to Service Kit 77070005
- 77070010 Air Filter, Cold Air Intake Replacement, Dry Media, Used to Service Kits 77060003AB, 77060006AB, 77060010AB, 77060011AB, 77070008
- 77070011 Air Filter, Cold Air Intake Replacement, Dry Media, Used to Service Kits 77060004AB, 77060016, 77060019AB
- 77070012 Air Filter, Cold Air Intake Replacement, Dry Media, Used to Service Kits 77060005AB, 77060009AB, 77070004, 77070006
- 77070038 Air Filter, Cold Air Intake Replacement, Dry Media, Used to Service Kits 77070029 and 77070032



A. 77070002



A. 77070005



A. 77060012



B.

## AIR SYSTEMS

### A. Air Filters- O.E. Performance Replacement

Constructed with factory tight seals, engineering level polyurethane, deep four-pleats of oiled cotton gauze and two layers of aluminum screen. This filter offers high flow and low restriction, better throttle response and increased filtration and horsepower. Filters are washable and reusable and come pre-oiled.

- P5153573** Air Filter, High Flow, O. E. Replacement, 2007-09 Compass/Patriot/Caliber, 2.4L/2.0L Non-Turbo
- P4510481** Air Filter, High Flow, O. E. Replacement, Oiled, 1999-03 3.5L 300/Concorde/ Intrepid
- P4510476** Air Filter, High Flow, O. E. Replacement, Oiled, 2001-06 PT Cruiser Non-Turbo
- P4510478** Air Filter, High Flow, O. E. Replacement, Oiled, 2003-05 Neon SRT4, 2001-05 Neon
- P4510472** Air Filter, High Flow, O. E. Replacement, Oiled, 2005-10 3.5L Magnum/300/Charger/Challenger, 2002-03 3.7L Liberty
- P5153987** Air Filter, High Flow, O. E. Replacement, Oiled, 2007-09 Caliber SRT4
- P5153991** Air Filter, High Flow, O.E. Replacement, Oiled, 2007-09 Avenger/Sebring 2.4L/3.5L
- P5153990** Air Filter, High Flow, O.E. Replacement, Oiled, 2007-09 Nitro 3.7L/ 4.0L



A. P5153573



B.

### B. Air Filter Service Kit

Services all Mopar oiled filters that are both washable and reusable.

- P5153376** Air Filter Service Kit, For "Oiled" Air Filters

## OILING COMPONENTS

### C. Windage Tray

Provides better engine lubrication by reducing windage and aeration at higher engine speeds. Includes mounting hardware and pan gasket.

- <sup>1</sup> **P5007278** Windage Tray, Neon 2.0L

### D. Oiling Components

- <sup>1</sup> **P4452889** Oil Filter, Hi-Performance, Black Finish, 2.2L/2.5L
- <sup>1</sup> **P4286741** Oil Pump, 2.2L, Except 1987 and Newer Turbo



C.



D.

Questions? Call the Mopar Direct Connection Techline at 1-888-528-HEMI (4364)

<sup>1</sup> Not legal on pollution-controlled vehicles or vehicles registered for highway use.

## FOUR- AND SIX-CYLINDER LATE MODEL VEHICLES

### EXHAUST SYSTEMS

#### A. Cat-Back Exhaust System

Features T304 2.25" stainless steel (aircraft quality) construction with mandrel-bent tubing, stainless band (Torca) clamps, and polished 3.125" dual wall tips. This free-flow system provides a horsepower and torque gain, improved fuel economy, and is CAD designed and dyno tested for optimal performance and sound.

- <sup>1</sup> P5155091 Cat-Back Exhaust System, Dual Exit, 2007-10 Avenger/Sebring/ AWD, 3.5L
- <sup>1</sup> P5153690 Cat-Back Exhaust System, 2007-09 AWD Caliber
- <sup>1</sup> P5153564 Cat-Back Exhaust System, 2007-09 FWD Caliber
- <sup>1</sup> P5155071 Cat-Back Exhaust System, Single Rear Exit, 2008-09 Caliber SRT4
- <sup>1</sup> P5153642 Cat-Back Exhaust System, Dual Rear Exit, 2.5" Pipe, 2005-08 Magnum/Charger, 3.5L
- <sup>1</sup> P5153366 Cat-Back Exhaust System, Single Rear Exit, 2.5" Pipe, 2005-08 Magnum/300/Charger, 3.5L
- <sup>1</sup> P5155114 Cat-Back Exhaust System, Single Exit With Square Tip, 2007-09 Compass/Patriot, AWD, 2.0L/2.4L
- <sup>1</sup> P5155113 Cat-Back Exhaust System, Single Exit With Square Tip, 2007-09 Compass/Patriot, FWD, 2.0L/2.4L
- <sup>1</sup> P5155014 Cat-Back Exhaust System, Dual Rear Exit, 2007-09 Avenger/Sebring, 3.5L, FWD
- <sup>1</sup> P5155110 Cat-Back Exhaust System, Single Rear Exit With Dual Square Tips, 2.5" Pipe, 2007-09 Nitro, 4.0L, V6
- <sup>1</sup> P5155111 Cat-Back Exhaust System, Single Rear Exit With Dual Square Tips, 2.5" Pipe, 2007-09 Nitro, 3.7L
- <sup>1</sup> P4510609 Cat-Back Exhaust System, Dual Center Exit Tips, 2.50" Pipe, 2004 - 05 Crossfire, 3.2L
- <sup>1</sup> P5007748 Cat-Back Exhaust System, Dual-Split, 3.5" Round Tips, 2001-05 PT Cruiser, Non-Turbo
- <sup>1</sup> P4510463 Cat-Back Exhaust System, Dual-Split Rear, Phantom Tips, 2.50" Pipe, 2003-07 PT Turbo
- <sup>1</sup> P5007746 Cat-Back Exhaust System, European Version (TUV Approved), Single Phantom Tip, Split Rear, 2.25" Pipe, 2001-06 PT Cruiser, 2.4L, FWD, Non-Turbo
- <sup>1</sup> P5007536 Cat-Back Exhaust System, Dual Driver Side Exit, Prowler Logo Etched Tips, 1999-05 Prowler, 3.5L, FWD, Non-Turbo
- <sup>1</sup> P4510461 Cat-Back Exhaust System, Split Rear, Split Rear Exit, 2.50" Pipe, 2003-05 Neon SRT4

#### B. Exhaust, Catalytic Converter Delete Kit

More power when you need it...that's what's behind this kit. Eliminating the catalytic converter means less restriction and more airflow and that means more power. And, as a bonus, you get the kind of engine sound that will show everyone that you mean business.

- <sup>1</sup> P4510649 Catalytic Converter Delete Kit, 2.50" Tubing, Comes With Replacement Front Pipe To Be Used With P4510461 Only, 2003-2005 Dodge Neon SRT 4

#### C. Exhaust Headers

- <sup>1</sup> P5153566 Header, 2007-09 Compass/Patriot/Caliber, FWD, Non-Turbo



A. P5153564



A. P4510609



A. P5007536



A. P4510463



A. P4510461



A. P5155071



A. P5155110



B.



C. P5153566

## FOUR- AND SIX-CYLINDER LATE MODEL VEHICLES

### TRANSAXLE COMPONENTS

#### A. Limited Slip Differentials

Qualife automatic torque-biasing (ATB) Limited-Slip Differentials are high-quality components that help make your ride even quicker. The unique design improves handling and steering, and powers both drive wheels under nearly all conditions. Internal components sense which wheel has better grip, then biases more power to that wheel. Installation Kit is required. A Limited Slip Differential is standard equipment on the 2004-05 Dodge SRT4.

- <sup>1</sup> P5007382 Differential, Limited Slip, 1995-05 Neon T-350 Manual Transmission and 2001-09 PT Cruiser, Non-Turbo
- <sup>1</sup> P5007923 Differential, Limited Slip, 2003 Neon SRT4, 2002-05 Stratus R/T Sedan, Sebring Convertible V6 T-850 Manual Transmission
- <sup>1</sup> P4510588 Installation Kit, Differential, Limited Slip, 2003 Neon SRT4, 2002-05 Stratus R/T Sedan, Sebring Convertible V6 T-850 Manual Transmission



A.



B. P5007435



C.



D.

#### B. Clutch Installation Kit

- <sup>1</sup> P5007435 Clutch Installation Kit, 1995-99 Neon

#### C. Short-Throw Shifters

- <sup>1</sup> P4510486 Shifter, Short-Throw, Hurst 2003-09 PT Turbo
- <sup>1</sup> P4510263 Shifter, Short-Throw, Hurst, 2001-09 PT Cruiser Non-Turbo

#### D. Gearshift Boot

Original equipment replacement part.  
05029257AA Boot, Gearshift, Neon SRT4

#### E. Drive Boots

- P5153906 Drive Boots, Rubber, 2008-09 Caliber SRT4

### WHEEL COMPONENTS

#### F. Hub and Bearing Kit

Kit can be used to upgrade standard Neon Wheel Hubs and Bearings or to service Neon ACR. Upgrade is recommended for non-ACR Neons used for racing purposes. ACR hubs and bearings should be replaced after 12 on-track hours. Kit includes one hub and one bearing. Same as production 1995-99 Neon ACR.

- <sup>1</sup> P5007314 Hub and Bearing Kit, 1995-99 Neon ACR



E.



F.

#### G. Wheel Stud Set

- P4452162 Wheel Stud, Front and Rear: 1984-88 Daytona, Pacifica, Shelby, Laser, Chrysler GS Turbo II, Turismo, GHL, Scamp, Rampage, TC-3, 024, Front: 1995-99 Neon
- P4349052 Wheel Stud, FWD, 12 mm x 1.5 mm Diameter, 2.2L/2.5L L/G-Bodies, Set



G.

Questions? Call the Mopar Direct Connection Techline at 1-888-528-HEMI (4364)

<sup>1</sup> Not legal on pollution-controlled vehicles or vehicles registered for highway use.

CHRYSLER / DODGE

## FOUR- AND SIX-CYLINDER LATE MODEL VEHICLES

### EXTERIOR BODY COMPONENTS

#### A. Charge Air Cooler

Original equipment replacement part.

05278944AD Air Intercooler, Neon SRT4, 2.4L

#### B. Fascia and Cladding

77DUB01002 Fascia, Front, Rallye Style, 2006-09 Caliber

77DUB01008 Sill & Door Cladding, Rallye Style, w/ Integral NACA duct, 2006-09 Caliber

#### Power Bulge Hoods (Not Shown)

05134116AC Power Bulge Hood (Neon SRT4)

### BRAKES

#### Brake Pads (Not Shown)

P5153994 Brake Pads, Axle Set, 2008-09 Caliber SRT4.

### BEARING

#### C. Main Bearings

P4120964 Bearings, Main, 1,2,4,5, Standard 2.2L



A.



B.



B.



C. P4120964

## MOPAR® RACING: Days of Thunder

Racing teams spend months and millions eking out every edge they can get from the smallest component to the most complex system. With Mopar® Racing Parts, you get the benefit from all that research without the back-breaking testing and garage temper tantrums. Nothing but pure power and astonishing aerodynamics, delivered in a victory cup.









PERFORMANCE

## DRAG RACING

### LC22R CHALLENGER DRAG PAK SERVICE PARTS

#### A. Engines and Blocks

- <sup>1</sup> P5155794 Crate Engine, 6.4L Hemi, EFI, Drag Pak
- <sup>1</sup> P5155189 Crate Engine, 6.1L Hemi, EFI, Drag Pak
- <sup>1</sup> P5155190 Crate Engine, 5.7L Hemi, EFI, Drag Pak
- <sup>1</sup> P5155197 Crate Engine, 5.9L Magnum, EFI, Drag Pak
- <sup>1</sup> P5155873 Engine Upgrade Kit, 6.1L to a 6.4L, (Includes Crank, Pistons, and Bearings)

#### B. Under Hood / Engine Components

- <sup>1</sup> P5155242 Cylinder Head, Aluminum, Assembly, 5.7L / 6.1L Hemi Drag Pak, Left
- <sup>1</sup> P5155241 Cylinder Head, Aluminum, Assembly, 5.7L / 6.1L Hemi Drag Pak, Right
- <sup>1</sup> P5155288 Intake Manifold, Aluminum, Single Plane, w/ Fuel Injector Bosses in Runners, Includes Gaskets, 5.7 / 6.1L / 6.4L, Drag Pak
- <sup>1</sup> P5155167 Oil Pan, Rear Sump, 8.0 qt., 5.7L / 6.1L / 6.4L, Drag Pak
- <sup>1</sup> P5155102 Engine Mounts, 5.9L, Drag Pak
- <sup>1</sup> P5155103 Engine Mounts, 5.7L / 6.1L / 6.4L, Drag Pak
- <sup>1</sup> P5155188 Crankshaft, Forged, 5.7L / 6.1L / 6.4L, Drag Pak
- <sup>1</sup> P5155285 Cylinder Head, Aluminum, Assembly, 58 CC Chamber, 176 CC Intake, 75 CC Exhaust, 2.020"/1.600" Valves W/ 11/32" Stem, Stock Port Windows and Valve Cover Rail, 5.9L Magnum, Drag Pak
- <sup>1</sup> P5153758 Gasket, Intake Manifold, 5.7L/6.1L, Set, Drag Pak
- <sup>1</sup> P5155180 Fuel Injection Kit, Partial, 5.9L Magnum Engine, Drag Pak
- <sup>1</sup> P5155202 Gasket, Throttle Body to Intake Manifold, Covers the MAP Sensor on the Intake, Cloverleaf Opening, Holley 4150 Bolt Pattern, Approximately .047" thick, 5.7L/6.1L, Drag Pak
- <sup>1</sup> P4510363 Throttle Body, Four-barrel, 6.1L/ 5.7L, Drag Pak
- <sup>1</sup> P5155226 Cable, Throttle Kit, Drag Pak
- <sup>1</sup> P5155430 Tray, Hood to Throttle Body, Carbon Fiber, Includes Braces to Mount to the Throttle Body and Two Stage Foam to Seal Against the Hood, Drag Pak

#### C. Body Components

- <sup>1</sup> P5155095 Hood, Carbon Fiber, Liffoff (no Mounting Holes), Includes Mounted High Temperature Epoxy Laminate Hood Scoop and Underhood Tray, Drag Pak
- <sup>1</sup> P5155098 Window, Right, Front, Polycarbonate, Drag Pak
- <sup>1</sup> P5155097 Window, Left, Front, Polycarbonate, Drag Pak
- <sup>1</sup> P5155227 Cable, Trunk Release, Drag Pak

#### D. Ignition and Electronics

- <sup>1</sup> P5155250 Panel, Master Switch, Drag Pak
- <sup>1</sup> P5155318 Window Module, Right, Drag Pak
- <sup>1</sup> P5155319 Window Module, Left, Drag Pak



A.



B.



C. Don Garlits Drag Pak



D. Roy Johnson's 2009 Drag Pak

## LC22R CHALLENGER DRAG PAK SERVICE PARTS

### Transmissions (Not Shown)

<sup>1</sup> P5155286 Bellhousing, 6-Speed Manual, Drag Pak

### A. Steering, Suspension, and Braking

<sup>1</sup> P5155259 Pedal, Brake Sled, Automatic, w/ Master Cylinder, Drag Pak

<sup>1</sup> P5155328 Pedal, Brake/Clutch Sled, Manual, w/ Master Cylinder, Drag Pak

<sup>1</sup> P5155176 Steering Rack, Manual Assembly, 2009-10 Drag Pak

<sup>1</sup> P5155203AB Module, Front L/R, Includes Knuckles, Wheel Hubs/Bearings, and Mark Williams Front Brake Kit, 2009 Drag Pak

<sup>1</sup> P5155703 Module, Front L/R, Includes Knuckles, Wheel Hubs/Bearings, and Mark Williams Front Brake Kit, 2010 Drag Pak

### Build Manual (Not Shown)

P5155107 Book, 2009 Drag Pak Build Manual

P5155775 Book, 2010 Drag Pak Build Manual

## BLOCKS

### B. Race Blocks- Cast Iron, R3

Building on Mopar heritage, the "R3" race block family offers the latest in design technology along with the options to meet your specific needs.

Features:

- Process-controlled castings utilizing high-strength cast iron
- 100% CNC machining with full statistical process control
- Thick deck surface and six-bolt cylinder head attachment (48° blocks) for improved sealing and reliability
- Various options that provide deck height potentials of 8.900-inch to 9.600-inch
- Tappet angles in both 59° (stock) and 48° are available (improved valve train geometry) (59° blocks are not recommended for use with roller tappets)
- Thicker main webbing and pan rail for improved rigidity
- Four-bolt mains in your choice of ductile iron or billet steel
- Machined for "LA" and Magnum head oiling, as well as engine mounts

<sup>1</sup> P5153743 Block, Cast Iron, Race, 340 Replacement, Siamese-bore, 4.175" Rough Bore

<sup>1</sup> P4876671AD Block, Cast Iron, Race, "R3", Siamese-bore, 3.998" Rough Bore, 9.000" Deck Height

<sup>1</sup> P4876381AB Block, Cast Iron, Race, "R3", Siamese-bore, 4.050" Rough Bore, 9.025" Deck Height

<sup>1</sup> P4876791AD Block, Cast Iron, Race, "R3", Siamese-bore, 3.998" Rough Bore, 9.200" Deck Height

<sup>1</sup> P4876673AD Block, Cast Iron, Race, "R3", Siamese-bore, 3.998" Rough Bore, 9.600" Deck Height

See chart for additional information.



A. Larry Griffith's 2009 Drag Pak



B. P4876381AB

Questions? Call the Mopar Direct Connection Techline at 1-888-528-HEMI (4364)

<sup>1</sup> Not legal on pollution-controlled vehicles or vehicles registered for highway use.

## DRAG RACING

### BLOCKS

#### A. Race Blocks- Cast Iron, R4

These Siamese-bore short deck, high-nickel alloy R4 Cast Iron Race Blocks are stress-relieved, shot-peened and machined for 60 mm roller cam bearings. They are 100% CNC machined and feature small main bearing size (2.25" journals) and four-bolt main caps. Blocks are available with either the P5/P9 head or Wedge head bolt pattern.

<sup>1</sup> P5007151AC Block, Cast Iron, "R4" Race, P5/P9 Heads

<sup>1</sup> P5007270AC Block, Cast Iron, "R4" Race, Wedge Heads

See chart for additional information.



A.

#### "R4" RACE BLOCKS

Part No.	Deck Nom.	Deck Min.	Cyl. Design	Over Bore	Cap Design	Tappet Angle	Journal Size	Notes
P5007151AC	8.585"	8.445"	Siamese	4.220"	4-Bolt — Steel	45/59°	2.25	(1,3)
P5007270AC	8.575"	8.445"	Siamese	4.220"	4-Bolt — Steel	48°	2.25	(1,2)

Notes:

1. Dry Sump application only, requires external oil pump and filter.
2. 48° cam tunnel machining requires 60 mm cam bearings P5007361 and cam UGL P5007437.
3. No distributor.

BLOCKS

A. Magnum/340 Replacement Block

Magnum and "LA" Blocks are designed for general high performance use and entry-level racing.

Features:

- Ready for assembly without the need for any additional machining
  - Bored and honed to standard bore size
  - Cam bearings and freeze plugs installed in block
  - Hardware kit included
  - Ductile Iron Main Caps with ARP bolts (four-bolt on the center three caps)
  - Dual motor mounts with "LA" and Magnum mounts (must use late 1970s 318 mount for left side)
  - Heavy Duty Casting with thicker deck and bore walls
  - Works with all stock-style engine components
  - P5153452 and P5153579 work with Magnum stock-style Hydraulic Roller Camshafts (requires tappet retainer kit P5155275)
  - Not recommended for use with aftermarket tie bar-style mechanical roller tappets
  - Siamese-bore (all except P5007552AB) - allows up to 4.220" bore size
  - Standard deck height - 9.600"
  - Setup for wet sump oiling system with oil drain holes in the valley
  - Magnum blocks can also be used for "LA" applications with dual oiling system provisions (LA oil passages to heads or Magnum oiling through pushrods, and flat tappet or hydraulic roller cams)
  - MPI provisions for Magnum crank trigger
  - 59° Tappet Bore - works with all stock-style cylinder heads and camshafts
- <sup>1</sup> **P5153478AB** Block, Cast Iron, 340 Replacement, Siamese-bore, 4.040" Finished Bore
- <sup>1</sup> **P5007552AB** Block, Cast Iron, 340, Non-Siamese-bore, 4.040" Finished Bore
- <sup>1</sup> **P5153579** Block, Cast Iron, Race, 5.2L Magnum/318 "LA", Siamese-bore, 3.910" Finished Bore
- <sup>1</sup> **P5153452** Block, Cast Iron, Race, 5.9L Magnum/360 "LA", Siamese-bore, 4.000" Finished Bore

See chart for additional information.



A. P5007552AB

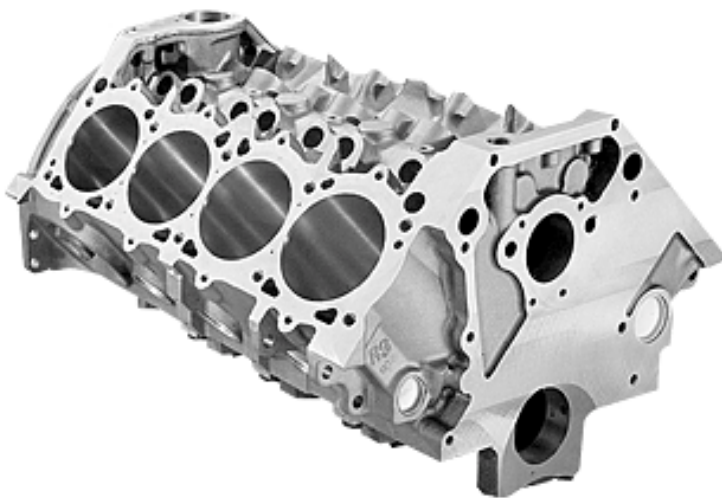

A.

Questions? Call the Mopar Direct Connection Techline at 1-888-528-HEMI (4364)

<sup>1</sup> Not legal on pollution-controlled vehicles or vehicles registered for highway use.

## DRAG RACING

### BLOCKS

#### SMALL BLOCK CAST IRON RACE BLOCKS

Part No.	Description	Deck Nom.	Deck Min.	Cyl. Design	Bore Size/Finish	Over Bore	Cap Design	Tappet Angle	Journal Size	Notes
P4876381AB	R3	9.025"	8.90"	Siamese	4.050" - Rough	4.220"	4-Bolt — Steel	48°	318/340	(2,3,4)
P4876671AD	R3	9.200"	8.90"	Siamese	3.998" - Rough	4.220"	4-Bolt — Iron	48°	318/340	(1)
P4876791AD	R3	9.200"	8.90"	Siamese	3.998" - Rough	4.220"	4-Bolt — Iron	59°	318/340	(5)
P4876673AD	R3	9.600"	9.30"	Siamese	3.998" - Rough	4.220"	4-Bolt — Iron	48°	318/340	(1)
P5007552AB	Mag/340	9.600"	9.30"	Non-siamese	4.040" - Honed	4.080"	4-Bolt — Iron	59°	318/340	(5,6)
P5153478AB	Mag/340	9.600"	9.30"	Siamese	4.040" - Honed	4.220"	4-Bolt — Iron	59°	318/340	(5,6)
P5153743	340	9.600"	9.30"	Siamese	4.175" - Rough	4.220"	4-Bolt — Iron	59°	318/340	(5)
P5153579	340	9.600"	9.30"	Siamese	3.910" - Honed	4.220"	4-Bolt — Iron	59°	318/340	(5,6)
P5153452	340	9.600"	9.30"	Siamese	4.000" - Honed	4.220"	4-Bolt — Iron	59°	360	(5,6)

Notes:

- 48° cam tunnel machining requires cam bearings P4876372 and cam UGL P4876633 or P4876634.
- 48° roller cam tunnel machining requires 50 mm roller cam bearings P4876707 and cam UGL P5007932 or P5007134.
- Dry Sump application only, requires external oil pump and filter.
- Steel billet cap application with four-bolt (center three caps)
- 59° cam tunnel machining uses stock-style camshaft.
- Comes with Camshaft Bearings installed in block.

**BLOCKS**

**A. Race Blocks- Aluminum, A4**

Designed for USAC Midget and Drag Racing. These lightweight blocks come with steel billet caps, ductile iron sleeves and hardware kit.

- <sup>1</sup> P5007467 Block, Drag, P5 Head
- <sup>1</sup> P5153903 Block, Drag, P9 Head
- <sup>1</sup> P5007636AB Block, Drag, W9 and W9RP Head
- <sup>1</sup> P5153612 Block, Midget, P9 Head
- <sup>1</sup> P5007466 Block, Midget, W9 and W9RP Head

See chart for additional information.

**GEAR DRIVES AND SERVICE PARTS**

**B. Gear Drives/Fuel Pump Eccentric**

Eliminates chain-induced cam timing fluctuations.

- <sup>1</sup> P4120484 Fuel Pump Eccentric, Moly-Coated, Small Block
- <sup>1</sup> P5249758 Gear Drive, Use With Fuel Pump Eccentric P4120484

**CRANKSHAFTS AND HARDWARE**

**C. Forged Crankshafts**

Surface hardened, 4340 forged steel Small Block Crankshafts feature radiused fillets at main and rod journals and a six-bolt flange.

- <sup>1</sup> P5007252 Crankshaft, Forged, 4.00" Stroke, 318/340 Main
- <sup>1</sup> P5007254 Crankshaft, Forged, 4.00" Stroke, 360 Main

**CYLINDER HEADS, GASKETS, AND HARDWARE**

**D. Cylinder Head Gasket Set- P5 Hemi**

Designed and engineered for NHRA Pro Stock Truck competition. Exclusively for "R4" Cast Iron Block/P5 Hemi Aluminum Cylinder Head combination.

- <sup>1</sup> P5007452 Gasket, Cylinder Head, Up to 4.180" Bore, "R4" Cast Iron Block/P5 Hemi Aluminum Head



A.



B.



C.



D. P5007452



**"R4" RACE BLOCKS**

Part No.	Deck Nom.	Deck Min.	Cyl. Design	Over Bore	Cap Design	Tappet Angle	Journal Size	Notes
P5007151AC	8.585"	8.445"	Siamese	4.220"	4-Bolt — Steel	45/59°	2.25	(1,3)
P5007270AC	8.575"	8.445"	Siamese	4.220"	4-Bolt — Steel	48°	2.25	(1,2)

Notes:

1. Dry Sump application only, requires external oil pump and filter.
2. 48° cam tunnel machining requires 60 mm cam bearings P5007361 and cam UGL P5007437.
3. No distributor.

Questions? Call the Mopar Direct Connection Techline at 1-888-528-HEMI (4364)

<sup>1</sup> Not legal on pollution-controlled vehicles or vehicles registered for highway use.

## DRAG RACING

### VALVE COVERS AND HARDWARE

#### A. Valve Covers- P5/P9

Magnesium Valve Cover Set for P5 or P9 Cylinder Heads.

- <sup>1</sup> P5153323 Valve Cover, Magnesium, P5 Heads, Set of two
- <sup>1</sup> P5153698 Valve Cover, Magnesium, P9 Head (Sold individually)
- <sup>1</sup> P5007218 Gasket, Valve Cover, O-Ring-style, P5 Heads, Set of two

#### B. Valve Cover Hardware, W8

These distinctive Magnesium Valve Covers are designed exclusively for use with Mopar W8 Cylinder Heads. Sold as a pair.

- <sup>1</sup> P4876676 Stud Kit, Wide "LA" and W8 Valve Covers, 10 Studs with Lock Nuts

### HEMI PRO STOCK

#### C. Block, Hemi Pro Stock

This 2006 Hemi Pro Stock Block is legal for NHRA Pro Stock racing and features 4.900-inch bore centers, four-bolt splayed mains and a 9.100-inch deck height as shipped.

- <sup>1</sup> P5153651 Block, Hemi Pro Stock

#### D. Block Hardware- Hemi Pro Stock

- <sup>1</sup> P5007138 Plate, Rear Seal Retainer, Hemi 99
- <sup>1</sup> P5155086 Seal Kit, Contains Front/Rear Crank and Front Camshaft, 1999-08 Pro Stock

#### E. Valve Covers, Hemi Pro Stock

Cast Magnesium Pro Stock Valve Covers with cast-in Hemi® logo are designed for Hemi Pro Stock Cylinder Heads only. Single plug design (sold individually).

- <sup>1</sup> P5007300 Valve Cover, 5.00" Bore Center, IHRA, Hemi Pro Stock

#### F. Cylinder Heads, Hemi Pro Stock

NHRA ProStock series heads are made of heavy-duty 355 aluminum and feature a 6-bolt head pattern. Both ports are designed with material for porting and the intake ports point straight at the carbs. Valve alignment is E-I-I-E-E-I-I-E. Heads uses individual rocker shaft system. Oil drain is located at each end of the head. Requires finish machining and porting.

- <sup>1</sup> P4876883AB Cylinder Head, Aluminum, 4.90" Bore Centers, Hemi 99
- <sup>1</sup> P5007178 Cylinder Head, Aluminum, 5.00" Bore Center, IHRA, Hemi Pro Mod
- <sup>1</sup> P5153447AB Cylinder Head, Aluminum, NHRA Hemi ProStock

### RACE BODIES

#### G. Funny Car

- <sup>1</sup> P5155205 Race Body, Complete Assembly, Top Fuel Funny Car, Charger



A.



B. P4876676



C.



D. P5007138



E.



F.



G.



RACE BODIES

A. Pro Stock

- <sup>1</sup> P5155300 Race Body, Complete Assembly, Pro Stock Drag , Avenger
- <sup>1</sup> P5155309 Race Body, Dash, Pro Stock Drag , Avenger
- <sup>1</sup> P5155306 Race Body, Decklid, Pro Stock Drag , Avenger
- <sup>1</sup> P5155299 Race Body, Door, Left, Pro Stock Drag , Avenger
- <sup>1</sup> P5155298 Race Body, Door, Right, Pro Stock Drag , Avenger
- <sup>1</sup> P5155297 Race Body, Front Clip, Pro Stock Drag , Avenger
- <sup>1</sup> P5155296 Race Body, Rear Section, Pro Stock Drag , Avenger
- <sup>1</sup> P5155307 Race Body, Spoiler, w/Spill Plates, Pro Stock Drag , Avenger

B. Sportsman

- <sup>1</sup> P5155480 Race Body, Complete Assembly, Sportsman Drag , Avenger
- <sup>1</sup> P5155475 Race Body, Decklid, Sportsman Drag , Avenger
- <sup>1</sup> P5155473 Race Body, Door, Left, Sportsman Drag , Avenger
- <sup>1</sup> P5155474 Race Body, Door, Right, Sportsman Drag , Avenger
- <sup>1</sup> P5155472 Race Body, Front Clip, Sportsman Drag , Avenger
- <sup>1</sup> P5155471 Race Body, Rear Section, Sportsman Drag , Avenger
- <sup>1</sup> P5155476 Race Body, Spoiler, w/Spill Plates, Sportsman Drag , Avenger



A. Allen Johnson's 2011 Avenger



B.

Questions? Call the Mopar Direct Connection Techline at 1-888-528-HEMI (4364)

<sup>1</sup> Not legal on pollution-controlled vehicles or vehicles registered for highway use.



# SPRINT CAR / MIDGET / DIRT LATE MODEL 16



## SPRINT CAR / MIDGET / DIRT LATE MODEL

### BLOCKS

#### A. Sprint Car Blocks, Aluminum, A8

Designed specifically for Sprint/Late Model race cars. They feature improved windage and a larger diameter camshaft. Steel main bearing caps, main bearing cap studs and fasteners are included.

- <sup>1</sup> P5153378 Block, Aluminum, A8 Sprint Car, 9.015" Deck Height
- <sup>1</sup> P5155076 Block, Aluminum, A8 Sprint Car, 9.015" Deck Height, 60 mm Cam
- <sup>1</sup> P5007905AB Block, Aluminum, A8 Sprint Car, 9.100" Deck Height
- <sup>1</sup> P5007909AB Block, Aluminum, A8 Sprint Car, 9.435" Deck Height

#### B. Drag/Midget Blocks, Aluminum, A4

Designed for USAC Midget and Drag Racing. These lightweight blocks come with steel billet caps, ductile iron sleeves and hardware kit.

- <sup>1</sup> P5007467 Block, Drag, P5 Head
- <sup>1</sup> P5153903 Block, Drag, P9 Head
- <sup>1</sup> P5007636AB Block, Drag, W9 and W9RP Head
- <sup>1</sup> P5153612 Block, Midget, P9 Head
- <sup>1</sup> P5007466 Block, Midget, W9 and W9RP Head

See chart for additional information.

### ENGINE BLOCK HARDWARE

#### C. Ductile Iron Cylinder Replacement Sleeve

For Aluminum Race Blocks.

- <sup>1</sup> P5007788 Sleeve, Cylinder Replacement, 4.355-inch Outside Diameter, 4.120-inch Inside Diameter, 5.700-inch Length, A8/ A4
- <sup>1</sup> P4510317AB Sleeve, Cylinder Replacement, 4.355-inch Outside Diameter, 4.120-inch Inside Diameter, 6.000-inch Length, A8.
- <sup>1</sup> P4510316 Sleeve, Cylinder Replacement, 4.400-inch Outside Diameter, 4.120-inch Inside Diameter, 5.600-inch Length, A8



A.



B.



C.

**CYLINDER HEADS, GASKETS, AND HARDWARE**

**A. Cylinder Heads, Raised Port, Aluminum, W9**

This partially-machined Aluminum Cylinder Head with raised intake and exhaust ports is recommended for use in Sprint and Midget cars.

Features:

- High-strength, lightweight A356 aluminum alloy casting
- Ports raised significantly higher than standard W9 cylinder heads
- Machined deck, intake surface, head bolts and valve cover rail
- Small cast ports allow for flexibility in porting (requires porting)
- Chamber is cast filled-in to allow very small machined chamber (requires machining)
- Requires machining for valve guides, spark plugs, intake screws, porting, valve spring pockets, rocker stands and injectors
- Designed for 13° valve angle
- For use on 48° V8 and four-cylinder blocks
- Recommended valve length: 6.040" intake and 6.060" exhaust
- Six-bolt head attachment design
- Accepts five-bolt Mopar valve cover and gasket
- Recommended for use with T&D rocker arms with 0.750" offset (custom order)



A.

<sup>1</sup> **P5007904** Cylinder Head, Aluminum, Raised Port, Semi Machined, Small Block, A4 Midget Block, W9RP

<sup>1</sup> **P5007904AB** Cylinder Head, Aluminum, Raised Port, with Extra Stiffening Ribs, Small Block, A4 Midget Block, W9RP

**B. Cylinder Heads, Aluminum, W9**

Designed with the professional racer in mind, Mopar W9 Aluminum Cylinder Heads incorporate the latest in "Paperless Design Technology" to give racers the leading edge. These heads feature high-strength, lightweight A356 aluminum alloy casting. Their thick decks permit small chambers for maximum compression ratios. Heads feature six-bolt head attachment design for sealing integrity, and raised intake and exhaust ports for maximum performance. Heads have a 15° valve angle, with additional material to permit "rolling" the head (except head P5007861, which is 13°). These heads are the same length as the block, to permit ease of installation with engine plates. Machined for 5.540" intake and 5.560" exhaust valves. Heads accept five-bolt Mopar valve cover and gasket.



B.

<sup>1</sup> **P5007861** Cylinder Head, Aluminum, 48°, Small Block, A4 Midget Block, W9 (13°)

<sup>1</sup> **P5007855** Cylinder Head, Aluminum, 48°, Small Block, A4 Midget Block, W9 (15°)

**C. Cylinder Heads, Aluminum, P9**

Semi-machined head (requires machining and porting) is designed for USAC Midget and Competition Eliminator Drag Racing. For use with A4 Blocks P5153612 or P5153903, or R4 Block P5007151AC.



C. P5153645

<sup>1</sup> **P5155090** Cylinder Head, P9, Semi-Finished, Cubed

<sup>1</sup> **P5153645** Cylinder Head, P9, Semi-Machined

## SPRINT CAR / MIDGET / DIRT LATE MODEL

### CYLINDER HEADS, GASKETS, AND HARDWARE

#### A. Racing Gaskets

Gaskets feature the latest in four-armor design composite gasket technology. Designed to accommodate both four- and six-bolt head attachment systems. Sold as an engine set.

**P4876666** Gasket, Cylinder Head, Lock Wire, to 4.18" Bore; Head Needs Groove Machining (W7, W8, W9 Heads), Set

#### B. Cylinder Head Stud Kits

Contains studs, nuts and washers. Complete engine set.

**P5153699** Stud Kit, Cylinder Head, A4 Engine Block with P9 Cylinder Heads

**P4876757** Stud Kit, Cylinder Head, Aluminum Block, W9 Heads

**P5007912** Stud Kit, Cylinder Head, Aluminum Block, W9 Raised Port Cylinder Head (A8 and A4 Engine Blocks with W9RP Cylinder Heads)

### INTAKE MANIFOLDS, HARDWARE, AND GASKETS

#### Aluminum Single Plane Intakes - Four-Barrel - Race (Not Shown)

<sup>1</sup> **P4532598** Intake Manifold, Aluminum, Single Plane, Four-barrel Carburetor, Rectangle Port, 9.000" Deck, W7/W8/W9 Cylinder Heads

<sup>1</sup> **P4876162** Intake Manifold, Aluminum, Single Plane, Four-barrel Carburetor, Rectangle Port, 9.600" Deck, W7/W8/W9 Cylinder Heads

#### C. Intake Manifold Gasket Sets

Custom fit for use with Mopar Sprint Car/Dirt Late Model cylinder heads. Kits come complete to service one engine set. Includes gaskets and end seals (where applicable).

**P5007153AB** Gasket, Intake Manifold, W9 Heads, 0.030" Thick

**P5007154AB** Gasket, Intake Manifold, W9 Heads, 0.045" Thick

**P5007155AB** Gasket, Intake Manifold, W9 Heads, 0.060" Thick

### VALVE COVERS

#### Valve Covers, P9 (Not Shown)

Magnesium Valve Cover set for P9 Cylinder Heads

**P5153698** Valve Cover, Magnesium, P9 Head (Sold individually)



A.



B.



C. P5007154

**CAMSHAFTS, LIFTERS, AND HARDWARE**

**A. Camshafts, UGL**

Race engines often require special camshafts. These lightweight UGL (unground lobe) Camshafts enable cam grinders to grind specific cam profiles to create a finished camshaft. Cannot be used in engine as is (for use with roller tappets and roller cam bearings only).

- <sup>1</sup> P5007134 Camshaft, Aluminum, UGL, 50 mm, "R" Blocks, Aluminum "A" Engine (W9/W9 RP)
- <sup>1</sup> P5007468 Camshaft, Aluminum, UGL, A4 Race Blocks (W9/W9 RP)
- <sup>1</sup> P5007906 Camshaft, UGL, 2.125", A8 Block (W9/W9 RP)
- <sup>1</sup> P5153305 Camshaft, UGL, 60 mm, Race, A8 (W9/W9 RP)
- <sup>1</sup> P5153519 Camshaft, UGL, 60mm Roller Journals, A4 (P9)

**B. Camshaft Bearings**

Complete engine set of roller camshaft bearings.

- <sup>1</sup> P5007911 Bearings, Camshaft, 2.125", Roller Bearing Applications, A8 Block
- <sup>1</sup> P5153700 Bearings, Camshaft, 60 mm, Roller Bearing Application, A4 with P9 Cylinder Heads
- <sup>1</sup> P5153324 Bearings, Camshaft, 60 mm, Roller Bearing Application, Requires Block Machining, A8 Block
- <sup>1</sup> P5007361 Bearings, Camshaft, 60 mm, Roller Bearing Applications, R4 or A4 Blocks with W9, W9RP

**C. Rear Cam Plates**

Packages include rear seal plate only.

- <sup>1</sup> P4510810 Cam Plate, Rear, Dirt Late Model, A8 Block

**ROCKER ARMS, SHAFTS, SUPPORTS, AND HARDWARE**

**D. Rocker Arm System, Pro Race**

Complete "Pro" Race Rocker Arm System made of high-strength aluminum, including shafts and bolts. Designed for high-rpm, high-load racing applications. Roller tip. Needle bearing center pivot. Requires hollow pushrods for oiling. May require grinding on block and head for clearance.

- <sup>1</sup> P5007470 Rocker Arm Set, 0.550" Offset, 1.6 Ratio, One Head Only, W9

**CRANKSHAFTS AND HARDWARE**

**E. Crankshaft, Sprint Car, Billet**

This lightweight 4330m Billet Steel Sprint Car Crank features 2.00-inch rod journals, 340 mains and a generic six-bolt rear flange.

- <sup>1</sup> P5007903 Crankshaft, Billet, Sprint Car, 3.80" Stroke

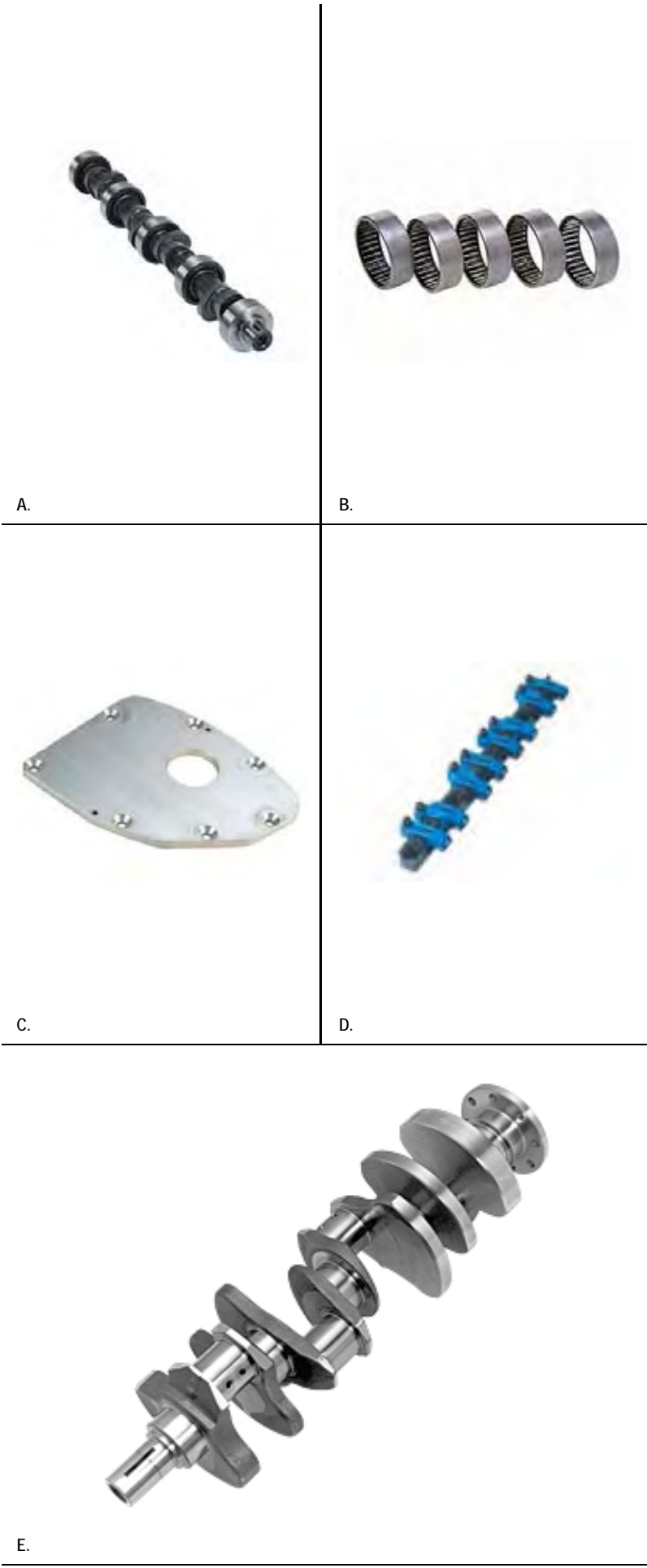

A.

B.

C.

D.

E.

Questions? Call the Mopar Direct Connection Techline at 1-888-528-HEMI (4364)

<sup>1</sup> Not legal on pollution-controlled vehicles or vehicles registered for highway use.

## SPRINT CAR / MIDGET / DIRT LATE MODEL

### CRANKSHAFTS AND HARDWARE

#### A. Crankshaft, Midget, Machined, A4

This fully-machined, 4340 steel Midget Crankshaft features a six-bolt generic bolt pattern on the crank flange.

- <sup>1</sup> P5153520 Crankshaft, Billet, Midget, 3.075" Stroke with 1.888" Rod Journals, A4 Block
- <sup>1</sup> P5007907 Crankshaft, Forged, Midget, 3.075" Stroke w/ 2.000" Rod Journals, A4 Block

#### B. Crankshaft, Midget, Unmachined, A4

This unmachined, 4340 forged steel Midget Crankshaft allows you to cut custom cranks. Requires complete machining.

- <sup>1</sup> P5007573 Crankshaft, Forged, Unmachined, Midget, 3.00"-3.25" Approx. Stroke, A4 Block



A.



B.

### GEAR DRIVES AND SERVICE PARTS

#### C. Front Cover Gear Drive Set

Designed for use with Mopar aluminum race blocks (A4).

- <sup>1</sup> P5249988 Gear Drive Package, Aluminum "A"
- <sup>1</sup> P5007469 Gear Drive Package, Aluminum, A4 Block
- <sup>1</sup> P5007908 Gear Drive Package, Aluminum, A8 Block



C.



D.

#### D. Hardware Kit

This Hardware Kit includes dowels, plugs, rear camshaft plate, screws, oil feed and scavenge tubes, oil crossover line and fittings, and camshaft bearing retaining screw.

- <sup>1</sup> P5153379 Hardware Kit - A8 Block

#### E. Replacement Timing Cover

Includes replacement timing cover without camshaft cover.

- <sup>1</sup> P5153460 Cover, Timing, Replacement, A8
- <sup>1</sup> P5153459 Cover, Timing, Replacement, A4
- <sup>1</sup> P5153461 Cover, Timing, Replacement, Aluminum "A"



E.



F.

#### F. Replacement Water Pump Drive

Includes water pump crank drive hub.

- <sup>1</sup> P5153462 Water Pump Drive, Aluminum, Replacement, A8/Aluminum "A"

#### G. Replacement Water Pump Mount

Includes Water Pump Mount for KSE crank-driven water pump.

- <sup>1</sup> P5153466 Water Pump Mount, Replacement, A8/Aluminum "A"



G.



H.

#### H. Replacement Gear Set

Includes cam, crank, and idler gears.

- <sup>1</sup> P5153457 Gear Set, Replacement, A4/ A8/ Aluminum "A"



**GEAR DRIVES AND SERVICE PARTS**

**A. Replacement Idler Set**

Includes idler shaft, roller bearing, spacer, two machined washers, three screws, and snap ring (gear not included).

<sup>1</sup> P5153458 Idler Set, Replacement, A4/ A8/ Aluminum "A"

**B. Replacement Cam Drive**

Includes cam drive adapter with hex drive.

<sup>1</sup> P5153463 Cam Drive, Aluminum, Replacement, A4/A8/Aluminum "A"

**C. Replacement Cam Cover**

Includes round billet Cam Cover.

<sup>1</sup> P5153465 Cam Cover, Aluminum, Replacement, A4/A8/Aluminum "A"

**D. Replacement Camshaft Hub and Hardware Kit**

Includes all the parts necessary to change camshafts (camshaft hub and all fasteners).

<sup>1</sup> P5007853 Hub and Hardware Kit, Camshaft, Replacement, A4/A8/Aluminum "A"

**E. Replacement Damper Seal Mount**

Includes aluminum billet Damper Seal Mount.

<sup>1</sup> P5153464 Damper Seal Mount, Replacement, A4/Aluminum "A"

**OILING COMPONENTS**

**F. Oil Pan Gaskets**

Gasket designed specifically for Mopar aluminum engines.

<sup>1</sup> P5007910 Gasket, Oil Pan, Aluminum A8 Engines

**BOOKS**

**G. Mopar Sprint Car Engine Build-Up Manual**

This engine build-up manual from Mopar presents package recommendations and guidelines for preparing 360 and 410 Sprint car and 358 Dirt Late Model racing engines. Detailed discussions on engine block, oiling system, cylinder heads, valve train, rotating assembly, and induction/fuel delivery are all included. In addition to engine package specifications and recommendations, this manual also includes a highly detailed 410 Sprint car engine build-up case study performed by one of today's top professional engine builders (64 pages).

P5007520AB Mopar Sprint Car Engine Build-Up Manual

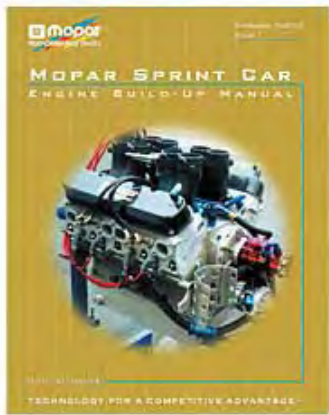

G.

Questions? Call the Mopar Direct Connection Techline at 1-888-528-HEMI (4364)  
<sup>1</sup> Not legal on pollution-controlled vehicles or vehicles registered for highway use.





PERFORMANCE  
RACING  
GE

1549; 026476376

340

82. PRE-5

27-11-1995 18:29

OFFER

## NASCAR® / LATE MODEL

### BLOCKS

#### A. Race Blocks- Cast Iron, R3

Building on Mopar's heritage, the "R3" race block family offers the latest in design technology along with the options to meet your specific needs.

##### Features:

- Process-controlled castings utilizing high-strength cast iron and a computer-controlled stress-relieving process.
- 100% CNC machining with full statistical process control
- Thick deck surface and six-bolt cylinder head attachment (48° blocks) for improved sealing and reliability
- Rough bore at 3.900" with various options that provide over-bore capacities up to 4.220" (in Siamese-bore versions)
- Various options that provide deck height potentials of 8.900" to 9.560"
- Tappet angles in both 59° (stock) and 48° are available (improved valve train geometry) (59° blocks are not recommended for use with roller tappets)
- Thicker main webbing and pan rail for improved rigidity
- Four-bolt mains in ductile iron and billet
- 318/340 main journal size
- Machined for pre-Magnum head oiling, as well as engine mounts

<sup>1</sup> **P4876671AD** Block, Cast Iron, Race, "R3", Siamese-bore, 3.998" Rough Bore, 9.000" Deck Height

<sup>1</sup> **P4876381AB** Block, Cast Iron, Race, "R3", Siamese-bore, 4.050" Rough Bore, 9.025" Deck Height

<sup>1</sup> **P4876791AD** Block, Cast Iron, Race, "R3", Siamese-bore, 3.998" Rough Bore, 9.200" Deck Height

<sup>1</sup> **P4876673AD** Block, Cast Iron, Race, "R3", Siamese-bore, 3.998" Rough Bore, 9.600" Deck Height

#### ENGINE BLOCK HARDWARE

#### B. Timing Chain Covers

Package includes Timing Chain Cover, seal, and gasket.

<sup>1</sup> **P5249930AB** Cover, Timing Chain, Production, Includes Seal and Gasket, 9.600" Deck, Small Block and V6

<sup>1</sup> **P4876632** Cover, Timing Chain, Sand Cast, Race, 9.00"-9.20" Deck, Race Water Pump/Front Motor Plate

#### C. Timing Chain Tensioner

Stabilizes camshaft timing by reducing timing chain slack. Use in place of Thrust Plate (P5249637).

<sup>1</sup> **P5007709** Timing Chain Tensioner, Small Block/ 3.9L/ 5.2L/ 5.9L Truck/Magnum/Jeep Engines



A. P4876381AB



B.



C.

## CRANKSHAFTS AND HARDWARE

### A. Forged Crankshafts

Surface hardened, 4340 forged steel Small Block Crankshafts feature radiused fillets at main and rod journals and a six-bolt flange.

- <sup>1</sup> P5007253 Crankshaft, Forged, 3.58" Stroke, 318/340 Main
- <sup>1</sup> P5007255 Crankshaft, Forged, 3.58" Stroke, 360 Main
- <sup>1</sup> P5007253AB Crankshaft, Forged, 3.58" Stroke, 50 lbs., 2.100" Rod Journal, Generic Rear Flange, NASCAR/Late Model, 318/340 Main
- <sup>1</sup> P5007959 Crankshaft, Forged, 3.58" Stroke, 50 lbs., 2.100" Rod Journal, Generic Rear Flange, 360 Main



A.

## CAMSHAFTS, LIFTERS, AND HARDWARE

### B. Camshafts, Roller, UGL, Race

The 48° tappet "R" blocks (R1, R2, R3, R4) require special camshafts. These lightweight UGL (unground lobe) camshafts enable cam grinders to grind specific cam profiles to create a finished cam. Cannot be used in engine as-is.

- <sup>1</sup> P5007932 Camshaft, Roller, UGL, Race, Roller Tappets, for 50 mm Roller Bearings P4876707, "R" Blocks
- <sup>1</sup> P5007437 Camshaft, Roller, UGL, Race, Roller Tappets, for 60 mm Roller Bearings P5007361, "R" Blocks
- <sup>1</sup> P4876633 Camshaft, Roller, UGL, Race, Roller Tappets, for Babbitt Bearings P4876372, "R" Blocks

### Camshafts (Not Shown)

P4529958\_Camshaft & Tappet.jpg

- <sup>1</sup> P4529958 Camshaft, Hydraulic, 284 Duration, .484" Lift, 106 CL, for Oval Track "A" Engines



B.

## CYLINDER HEADS, GASKETS, AND HARDWARE

### C. NASCAR Touring Series Cylinder Head

This partially-machined A356 aluminum alloy Cylinder Head is approved by NASCAR for its Touring Series. Designed and manufactured for Mopar by Brodix, this head features high-flow 239 cc intake, raised intake ports, phosphorous bronze valve guides and ductile iron valve seats. Use with intake manifold P4876829AB. (Port matching required with this intake manifold).

- <sup>1</sup> P5007928 Cylinder Head, Aluminum, NASCAR Touring Series



C.

Questions? Call the Mopar Direct Connection Techline at 1-888-528-HEMI (4364)

<sup>1</sup> Not legal on pollution-controlled vehicles or vehicles registered for highway use.

## NASCAR® / LATE MODEL

### CYLINDER HEADS, GASKETS, AND HARDWARE

#### A. Cylinder Heads, W2 Cast Iron

These heads feature flat-machined rocker pads that require T&D Pro Race Rocker Arms and long valves. Heads oiled through tappets and hollow pushrods. Older style rocker stands and rocker systems do not work with these heads.

- <sup>1</sup> **P5007708AB** Cylinder Head, Cast Iron, Race, 2.02" Intake, 1.60" Exhaust, 48° Tappet, 47cc Chamber, W2
- <sup>1</sup> **P5007445AB** Cylinder Head, Cast Iron, Race, 2.02" Intake, 1.60" Exhaust, 48° Tappet, 65 cc Chamber, W2
- <sup>1</sup> **P5249769** Cylinder Head, Cast Iron, Race, 2.02" Intake, 1.60" Exhaust, 59° Tappet, 65cc Chamber, W2

#### B. Cylinder Heads, Aluminum, W9

Designed with the professional racer in mind, Mopar W9 Aluminum Cylinder Heads incorporate the latest in "Paperless Design Technology" to give racers the leading edge. These heads feature high-strength, lightweight A356 aluminum alloy casting. Their thick decks permit small chambers for maximum compression ratios. Heads feature six-bolt head attachment design for sealing integrity, and raised intake and exhaust ports for maximum performance. Heads have a 15° valve angle, with additional material to permit "rolling." These heads are the same length as the block to permit ease of installation with engine plates. Machined for 5.540-inch Intake and 5.560-inch Exhaust valves. Heads accept five-bolt Mopar valve cover and gasket.

- <sup>1</sup> **P5007065AB** Cylinder Head, Aluminum, 48°, Small Blocks, W9

See chart for additional information.

#### C. Gaskets, Cylinder Head, Composite

Thick, 0.040" to 0.042" gaskets can be used for replacement or competition applications up to 12.5:1 compression ratio. Sold as an engine set. Small Block four-bolt pattern.

- <sup>1</sup> **P4349557** Gasket, Cylinder Head, Composite Material, up to 4.06" Bore, 0.040" to 0.042" Compressed Thickness, Small Block
- <sup>1</sup> **P4120094** Gasket, Cylinder Head, Composite Material, Up to 4.125" Bore, Up to 12.5:1 CR, Small Block



A.



B.



C.

### NASCAR CYLINDER HEADS

Part Number	Description	Material	Chamber Size	Tappet Angle	Valve Angle	Valve Size	Valve Stem Size	Int. Port Volume	Int. Flow @ .600"	Int. Port Shape	Exh. Port Shape	Valve Cover	Approx Weight
P5007445AB	W2	Cast iron	65 cc	48°	15°	2.02"/1.60"	3/8"	190 cc	265 cfm	Oval W2	"D" W2/5	Std 5 bolt	51
P5007708AB	W2	Cast iron	47 cc	48°	15°	2.02"/1.60"	3/8"	190 cc	265 cfm	Oval W2	"D" W2/5	Std 5 bolt	51
P5249769	W2	Cast Iron	65 cc	59°	18°	2.02"/1.60"	3/8"	180 cc	260 cfm	Oval W2	"D" W2/5	Std 5 bolt	51
P5007065AB	W9	Aluminum	62 cc	48°	15°	N/A	11/32"	200 cc	290 cfm	Rect. W8/9	"D" W7/9	Std 5 bolt	22
P5007928	Brodix NTS	Aluminum	67 cc	59°	18°	2.15"/1.60"	11/32"	N/A	N/A	Rect. W5	"D"	5 bolt	N/A

**EXHAUST SYSTEMS**

**A. Exhaust Gasket Set**

- <sup>1</sup> P4876103AB Gasket, Exhaust Header, W-2 Dual Pattern Race, "A" Engine
- <sup>1</sup> P5007157 Gasket, Exhaust Header, W-8/W-9, "A" Engine, Set

**VALVE COVERS AND HARDWARE**

**B. Valve Covers, Wide**

Uses stock production gaskets. Features Mopar Pentastar logo and reversed lip design that allows the cover to be wider on the same gasket surface. The extra width allows for larger valve springs and longer rocker arms. Five-bolt covers. Requires use of Mopar Valve Cover Stud Attaching Kit (P4876676).

- P4876124 Valve Cover, Wide, Stock Production Small Blocks and W2/W5/W7/W9 Flanges, Set

**Valve Cover Hardware, Wide (Not Shown)**

- P4876676 Stud Kit, Wide "LA" and W8 Valve Covers, 10 Studs with Lock Nuts
- P5249581AB Gasket, Valve Cover, Five-Bolt Rubber with Steel Shim Reinforcement, 318/340/360/ "A" Engines up to 1992, Set

**OIL, FUEL, AND WATER PUMPS**

**C. Oil Pump Assembly**

This high-output Oil Pump Assembly provides a 25% increase in oil volume. Ideal replacement for stock pump in high-performance applications.

- <sup>1</sup> P4286589 Oil Pump Assembly, Small Block, 3.9L V6

**D. Fuel Pump Eccentric, Moly-Coated**

The moly coating on this Fuel Pump Eccentric significantly reduces friction and wear.

- <sup>1</sup> P4120484 Fuel Pump Eccentric, Moly-Coated, Small Block

**E. Water Pump - Race**

High-performance water pump for racing applications.

- <sup>1</sup> P4876548 Water Pump, Aluminum, Race, use with Timing Chain Cover P4876632

**NASCAR**

**F. NASCAR Sprint Cup Race Block**

- <sup>1</sup> P5007427 Block, NASCAR Sprint Cup, R5
- <sup>1</sup> 05045291AB Block, NASCAR Sprint Cup, R6

Contact Dodge Motorsports South ((704) 786-1909) for R6/P8 racing parts.



A.



B.



C.



D.



E. P4876548



F.

Questions? Call the Mopar Direct Connection Techline at 1-888-528-HEMI (4364)

<sup>1</sup> Not legal on pollution-controlled vehicles or vehicles registered for highway use.

## NASCAR® / LATE MODEL

### NASCAR

#### A. NASCAR Sprint Cup Cylinder Heads

Designed for the NASCAR Sprint Cup program. This partially machined head is made from high-strength aluminum alloy and features a unique six-bolt cylinder head bolt pattern.

<sup>1</sup> P5007428 Cylinder Head, Aluminum, NASCAR Sprint Cup, P7

<sup>1</sup> 05045292AA Cylinder Head, Aluminum, NASCAR Sprint Cup, P8

Contact Dodge Motorsports South ((704) 786-1909) for R6/P8 racing parts.

#### NASCAR Sprint Cup Intake Manifolds (Not Shown)

<sup>1</sup> 05045404AA Intake Manifold, Aluminum, NASCAR Sprint Cup, R6/P8

<sup>1</sup> 68101616AA Intake Manifold, Aluminum, NASCAR Sprint Cup, R6/P8

Contact Dodge Motorsports South ((704) 786-1909) for R6/P8 racing parts.

#### NASCAR Nationwide Intake Manifolds (Not Shown)

<sup>1</sup> 05045406AA Intake Manifold, Aluminum, NASCAR Nationwide, R6/P8

#### B. NASCAR Sprint Cup Fuel Components

<sup>1</sup> P5007652 Fuel Pump, NASCAR Sprint Cup, R5 Block

<sup>1</sup> P5007745 Pushrod, Fuel Pump, NASCAR Sprint Cup, R5 Block

#### NASCAR Sprint Cup Water Pump (Not Shown)

05045164AC Water Pump Housing, NASCAR Sprint Cup, R6/P8

### BOOKS

#### C. Mopar 358 Oval Track Engine Build-Up Manual

This manual is recommended for anyone who wants to build a Mopar 358 cid oval track race engine. Written in conjunction with Dodge Motorsports race engineers, this step-by-step build-up manual contains information on cylinder block preparation, oiling system planning and modifications, cylinder head and valve train preparation, short block preparation and induction setup. Also included are complete parts and supplier listings. All the information you need to know, straight from the pros. (56 pages)

P5007373AB Mopar 358 Oval Track Engine Build-Up Manual

#### D. Mopar Late Model Oval Track Engine Build-Up Manual

This manual is recommended for anyone who wants to build a Mopar 340-410 cid Late Model oval track racing engine. It describes all of the parts and procedures necessary to build a Late Model oval track engine for competition. Written by Mopar race engineers, this step-by-step build-up manual contains information on cylinder block preparation, oiling system planning and modifications, cylinder head and valve train preparation, short block preparation, and induction and ignition setup. Also included are complete part and supplier listings. Whether you're racing in CASCAR, NASCAR, USAR Pro Cup, or any other Late Model sanctioning organization, this manual contains all of the information you need to know straight from the people who know best. (96 pages)

P5007450AB Mopar Late Model Oval Track Engine Build-Up Manual



A.



B.



C.

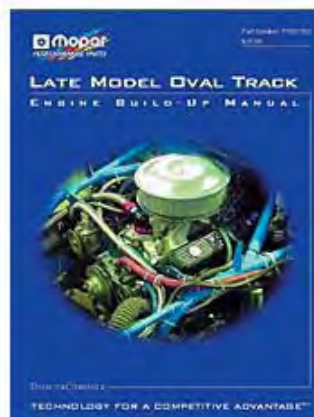

D.



## BOOKS

## A. Mopar Oval Track Modifications - 3rd Edition

This is the book every Mopar oval track racer must have. It includes complete engine and chassis build-up information. Speed secrets and racing tips are directed primarily toward Chrysler-Plymouth-Dodge V8 engines (273-318, 340-360 "A" engines; 361-383-400 "B" engines; 413-426W-440 "RB" engines; 5.2L and 5.9L Magnum engines). Additional chapters include information on automatic and manual transmissions, driveshafts and rear axles, front and rear suspension, steering and handling, brakes, shocks, wheels and tires, body and chassis. Late Model, Sprint Car, and NASCAR Truck racing specifications and performance recommendations are also included. Summarizes more than four decades of Chrysler-Plymouth-Dodge involvement in oval track engineering and on-track testing. (500 pages)

P5249959AB Mopar Oval Track Modifications, 3rd Edition



A.

---



## JEEP® AND RAM: The Last American Heroes

Hauling stuff or hauling out of town? Getting from A to B means exploiting every ounce of power your Jeep® or Ram is capable of generating. It means having the muscle to tackle the roughest roads, the loneliest trails, the ugliest terrain. Count on Mopar® Performance Parts to take you there.

PERFORMANCE





SACRAMENTO STATE UNIVERSITY  
SCHOOL OF BUSINESS

0573-04

0110

JEEP® / RAM 18



## JEEP/RAM

### BLOCKS

#### A. Long Blocks

Need more power and low-end torque out of your 1991-06 Jeep Wrangler or Cherokee inline six-cylinder engine? Mopar's new 4.7L Stroker Long Block engine assembly is the solution to beef up the Jeep 4.0L I-6 for towing, offroading, or rock crawling.

- <sup>1</sup> P5155209 Block, Long, 4.7L Stroker, I6, 1991-97 Jeeps, 1998 Cherokee/Wrangler
- <sup>1</sup> P5155627 Block, Long, 4.7L Stroker, I6, 1999-04 Grand Cherokee, 2000-06 Wrangler
- <sup>1</sup> P5155210 Block, Long, 4.7L Stroker, I6, 2000-01 Cherokee

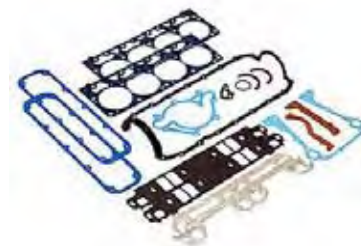

### ENGINE BLOCK HARDWARE

#### B. Engine Teardown Gasket Sets

All the gaskets needed for a complete engine teardown, including oil pan, cylinder head, valve cover, timing chain cover, intake manifold, exhaust and oil pump.

- P4529245 Gasket, Engine Teardown, 4.0L Jeep Engines, up to 1998

A.

B.

### TIMING CHAIN AND SPROCKETS

#### C. Timing Chain Tensioner

Stabilizes cam timing by reducing timing chain slack. Can be used instead of Thrust Plate P5249637.

- <sup>1</sup> P5007709 Timing Chain Tensioner, Small Block/ 3.9L/ 5.2L/ 5.9L Truck/Magnum/Jeep Engines

#### D. Double Roller Chain and Sprocket

High-strength Double Roller Chain and Sprocket Sets provide added durability and decreased rotational friction compared to production silent chains. Sets include Magna-Fluxed sprockets and roller timing chain.

- <sup>1</sup> P5249519 Roller Chain and Sprocket, Double, 1-Bolt Mount, One Keyway, 2.5L/4.0L Jeep Engines up to 1998



### VIBRATION DAMPERS

#### E. Vibration Damper

Compatible with production crankshaft and piston rod weight.

- P5249535 Vibration Damper, Production Replacement, V-Belt, 4.2L Jeep Engines

#### F. Damper Attachment Package

Contains all the parts necessary to attach the vibration damper to the crankshaft.

- P4529677 Hardware Kit, Damper, 2.5L/4.0L Jeep Engines

C.

D.



E.

F.



A. Damper Not Included



B.



C.



D.



E.



F. P4529242



F. P4876048

## VIBRATION DAMPERS

### A. Damper Degree Timing Tape

Improve timing accuracy with this Damper Degree Timing Tape. Marked in 90° increments. Self-adhesive strip adheres to the crank vibration damper for clear identification of marks. Permits initial total spark advance up to 60° instead of only 10°-15° as on chain case timing tab.

**P4529070AB** Damper Degree Timing Tape

## CAMSHAFTS, LIFTERS, AND HARDWARE

### B. Camshafts

Mopar Performance Camshafts are designed and engineered exclusively for your engine. A wide range of profiles are available, from mild to wild. All camshafts are developed, dyno'd and track-tested by Mopar engineers for increased power and rpm potential while maintaining reliability and the best possible low-speed characteristics, including torque and idle quality. Mopar camshafts offer the best horsepower-to-dollar-spent value. Each package contains the camshaft, camshaft lube, instruction sheet, and tappets.

<sup>1</sup> **P4529228AD** Camshaft, Hydraulic, 4.0L Jeep Engines, up to 1998 .430/.430 Lift

<sup>1</sup> **P4529229AD** Camshaft, Hydraulic, 4.0L Jeep Engines, .440/.440 Lift

Note: For flat tappet camshafts, Mopar recommends the use of a high-zinc oil for maximum performance.

### C. Offset Camshaft Key

For centerlining your camshaft, these hardened keys are color coded in 1°, 2°, 3°, 4° and 5° increments. Production key is used for zero offset.

**P5249600** Camshaft Keys, Offset, 3.7L/ 3.9L/ 4.7L/ 5.2L/ 5.9L Truck Magnum/Jeep Engines

### D. Hydraulic Flat Tappets

<sup>1</sup> **P4529220AB** Tappet, Hydraulic, Small Block/ 2.5L/4.0L Jeep Engines, Sold Individually

### E. Pushrods

<sup>1</sup> **P4529675** Pushrod, 1987-89 4.0L Jeep Engines, Set of 12

## CYLINDER HEADS, GASKETS, AND HARDWARE

### F. Cylinder Head Gaskets

<sup>1</sup> **P4529242** Gasket, Cylinder Head, 4.0L Jeep Engines, Sold Individually

## JEEP/RAM

### ROCKER ARMS, SHAFTS, SUPPORTS, AND HARDWARE

#### A. Rocker Arms, Roller

This single cylinder Roller Rocker Arm Set for Jeep vehicles includes two rockers, two support stands, rocker shaft, and screws. Extruded, anodized aluminum rockers. Can be used with hydraulic, mechanical or roller camshafts. Roller tip and center pivot bearing reduce internal friction. Provides exact geometry and 1.6:1 ratio. Adjustable, oil-through-pushrod-style. 2.5L and 4.0L engines require aftermarket spacer for valve cover clearance.

<sup>1</sup> P4529885 Rocker Arm, Roller, 1.6:1 Ratio, Single Cylinder, 2.5L/ 4.0L/ 4.2L Jeep Engines

#### B. Rocker Arm, Heavy-Duty

Heavy-duty stamped rocker for use with hydraulic camshafts only. Can be used to service stock Jeep® engines. Sold individually.

<sup>1</sup> P4529221 Rocker Arm, Roller, 2.5L/4.0L Jeep Engines



### VALVE COVERS AND HARDWARE

#### C. Valve Covers, Cast Aluminum, Black Wrinkle

Bold looking Black Wrinkle Cast Aluminum Valve Cover Sets for Mopar Magnum trucks and Jeep vehicles. Magnum valve covers feature the Mopar Pentastar Magnum logo, while the Jeep valve cover features the Jeep logo. Sets include attaching screws, grommets, baffle and oil filler cap. Gaskets must be purchased separately.

<sup>1</sup> P4876388 Valve Cover, Black Wrinkle, 1981-86 4.2L Jeep Engines

<sup>1</sup> P5007854 Gasket, Valve Cover, 4.2L Jeep Engines

### VALVES AND VALVE TRAIN HARDWARE

#### D. Valve Spring Retainers

Restore worn or damaged valve train components to factory specifications with these durable Valve Spring Retainers. Use with 7° locks. Features an 8 mm valve stem diameter.

P4452032 Retainer, Valve Spring, Chrome Moly, 7 Degree, 8mm Stem Diameter, Single, 2.2L/2.5L SOHC and 5.2L/5.9L Magnum Engines

P4529616 Retainer, Valve Spring, Jeep 4.2L and 5.9L Engines

P4529217 Retainer, Valve Spring, Steel, use with Conical Springs P4529215, 2.5L/4.0L Jeep Engines

#### E. Valves

These stainless steel Valves have swirl-polished underheads that have no flat or ski jump areas. They feature an 8 mm stem and one square groove. Does not fit P5153847 head.

<sup>1</sup> P5249880 Valve, Exhaust, 1.56" Diameter, 4.93" Stem Length, 2.5L/4.0L Jeep Engines

A.

B.



C.

D.



E.



## VALVES AND VALVE TRAIN HARDWARE

### A. Valve Springs

High-pressure Valve Springs can be used on exhaust and intake valves for all high-performance applications. They feature a shorter fully-compressed height and allow for increased valve lift. Springs maintain spring load at higher rpms. A must for high-performance camshafts. With a single spring, the damper is installed inside the main spring; with a dual spring, the damper is installed between the inner and outer springs. There are no dampers in the triple springs. The retainers listed are the basic recommendation. Check the actual retainer listing for other options such as added installed height, materials and lock size. Sold individually.

<sup>1</sup> P4529215 Valve Spring, Conical, 1988-02 2.5L/4.0L Jeep Engines

<sup>1</sup> P4529214 Valve Spring, Cylindrical, 1981-87 2.5L/4.0L Jeep Engines

### B. Valve Seals

Made of high-temperature Viton material, these Valve Seals feature a full, or semi-umbrella, shape for best dual-purpose use. Helps prevent oil seepage down the valve guides. Not recommended for use with dual valve springs. Sold in sets of 16.

<sup>1</sup> P4529240 Valve Seals, 8 mm Stem, 4.0L Jeep Engines

### C. Valve Keepers

These single-groove-style Valve Keepers are made from hardened steel. Each features an 8° angle and an 8 mm stem diameter single groove. Used with P4529616 and P4529217 retainers. They can be used for restoration or performance applications. Sold in cylinder head sets of 16 (note that two sets are required for all six-cylinder and V8 engines). Does not fit P5153847 Magnum cylinder head.

<sup>1</sup> P4529218 Valve Keepers, For Retainers P4529216-17, 2.5/ 4.0L/ 5.2L/ 5.9L Truck Magnum/Jeep Engines

## INTAKE MANIFOLDS, HARDWARE, AND GASKETS

### D. Intake/Exhaust Gaskets

Jeep six-cylinder engines use a common intake/exhaust manifold gasket design. This gasket is designed for direct replacement (includes engine set).

P4529243 Gasket, Intake/Exhaust Manifold, 4.0L Jeep Engines



A.



A.



B.



C.

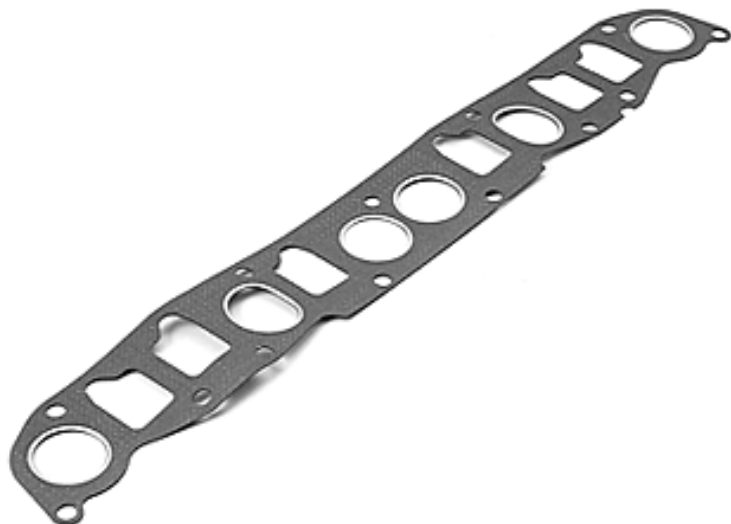

D.

Questions? Call the Mopar Direct Connection Techline at 1-888-528-HEMI (4364)

<sup>1</sup> Not legal on pollution-controlled vehicles or vehicles registered for highway use.

## JEEP/RAM

### INTAKE MANIFOLDS, HARDWARE, AND GASKETS

#### A. MPI Conversion Kits

Designed to make your 1981-90 Jeep® vehicle more efficient and powerful. The kit replaces the stock carburetor, intake manifold and other major components with multi-point injection (MPI). Each cylinder has its own injector that is activated sequentially according to the firing order to precisely control individual fuel requirements. These MPI Conversion Kits are self-compensating and run equally well from sea level to terrain above 12,000 feet. Mechanical components are based on production 1995 Jeep vehicle parts.

- <sup>1</sup> P5249686AE EFI Conversion Kit, Automatic Transmission, Emissions Exempt D-265-21\*\*, 1981-90 4.2L Jeep Engines
- <sup>1</sup> P5249610AE EFI Conversion Kit, Manual Transmission, Emissions Exempt D-265-21\*\*, 1981-90 4.2L Jeep Engines
- <sup>1</sup> P5007146 Engine Controller, Automatic Transmission, 1981-90 4.2L Jeep Engines
- <sup>1</sup> P5007147 Engine Controller, Manual Transmission, 1981-90 4.2L Jeep Engines
- <sup>1</sup> P5007150 Fuel Pump, Auto/Manual Transmission, 1981-90 4.2L Jeep Engines
- <sup>1</sup> P5007148AB Wiring Harness, 1981-90 4.2L Jeep Engines



A.

#### B. MPI Conversion Service Parts

- <sup>1</sup> P5249687 Vibration Damper, V Belt, 1981-90 4.2L Jeep Engines
- <sup>1</sup> P5249688 Vibration Damper, Serpentine Belt, 1981-90 4.2L Jeep Engines
- <sup>1</sup> P5007146 Engine Controller, Automatic Transmission, 1981-90 4.2L Jeep Engines
- <sup>1</sup> P5007147 Engine Controller, Manual Transmission, 1981-90 4.2L Jeep Engines
- <sup>1</sup> P5007150 Fuel Pump, Auto/Manual Transmission, 1981-90 4.2L Jeep Engines
- <sup>1</sup> P5007148AB Wiring Harness, 1981-90 4.2L Jeep Engines
- <sup>1</sup> P5007046 Crank Sensor Bracket, 4.2L Jeep Engines

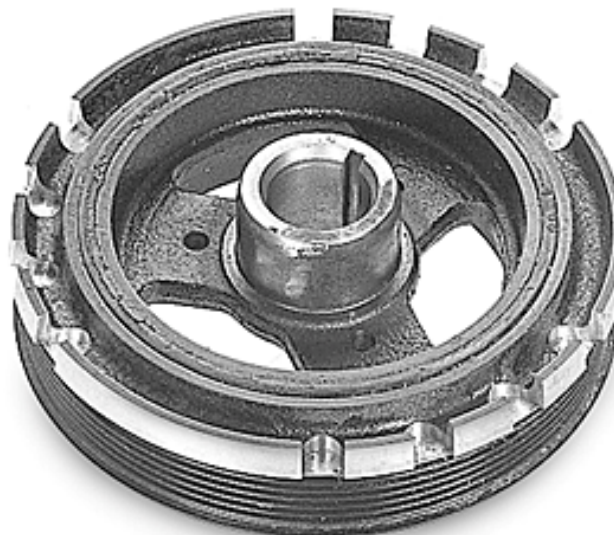

B.

## AIR SYSTEMS

#### C. Cast Air Cleaner Systems

Cast aluminum lid is painted black, with Mopar Pentastar or Jeep logo to match the style of the Black Wrinkle Cast Aluminum Valve Covers. Includes 12-3/4" element.

- P5007067 Air Cleaner, Cast, Jeep Vehicles



C. P5007067

**AIR SYSTEMS**

**A. Cold Air Intake Systems - Jeep**

Heat up your engine with a steady flow of cold air! These bolt-on systems are designed to allow cooler outside air through a directional cone filter, directly into the intake manifold. They provide noticeable horsepower and torque gains under varying atmospheric conditions. Kits include all mounting hardware and a washable/reusable filter. Do not oil dry media filters. CARB-approved E.O.#D-265-22.

- 77060007AB** Cold Air Intake System, Dry Media, 2004-06 Wrangler, 4.0L
- 77060013AB** Cold Air Intake System, Dry Media, 2005-06 Liberty, 3.7L
- 77060010AB** Cold Air Intake System, Dry Media, 2005-09 Grand Cherokee/Comander, 5.7L
- 77060011AB** Cold Air Intake System, Dry Media, 2006-09 Grand Cherokee, 6.1L
- 77060012AB** Cold Air Intake System, Dry Media, 2007-09 Caliber/Compass/Patriot, 1.8L/2.0L/2.4L, Non-Turbo
- 77060081** Cold Air Intake System, Dry Media, 2007-10 Wrangler 3.8L
- P5153368** Cold Air Intake System, Oiled Filter, 1997-03 Wrangler, 4.0L

**B. Cold Air Intake Systems - Truck**

Heat up your engine with a steady flow of cold air! These bolt-on systems are designed to allow cooler outside air through a directional cone filter, directly into the intake manifold. They provide noticeable horsepower and torque gains under varying atmospheric conditions. Kits include all mounting hardware and a washable/reusable dry media filter. Do not oil dry media filters.

- 77060008AB** Cold Air Intake System, Dry Media, 1998-00 Dakota 5.2L, 1998-02 Dakota 5.9L
- 77060020AB** Cold Air Intake System, Dry Media, 2002-03 Ram, 4.7L
- 77060005AC** Cold Air Intake System, Dry Media, 2003-05 5.7L Ram 1500
- 77060009AB** Cold Air Intake System, Dry Media, 2004-06 5.7L Durango
- 77070006** Cold Air Intake System, Dry Media, 2006-08 5.7L Ram 1500
- 77070004** Cold Air Intake System, Dry Media, 2007-08 Durango/Aspen, 5.7L
- 77070023** Cold Air Intake System, Dry Media, 2009 5.7L Ram 1500

**C. Cold Air Intake Systems - Truck- Diesel**

- 77070030** Cold Air Intake System, Dry Media, 2003-07 Ram (DR/DH) 2500/3500, 5.9L Diesel
- 77070028** Cold Air Intake System, Dry Media, 2007-09 Ram (DH/D1) 2500/3500, 6.7L Diesel
- 77070027** Cold Air Intake System, Dry Media, 2010 Ram (DJ/D2) 2500/3500, 6.7L Diesel



A.



B. 77070008



B. 77070005



B. 77060020AB



B. 77070006



B. 77070004



C. 77070030

Questions? Call the Mopar Direct Connection Techline at 1-888-528-HEMI (4364)

<sup>1</sup> Not legal on pollution-controlled vehicles or vehicles registered for highway use.

## JEEP/RAM

### AIR SYSTEMS

#### A. Air Filters- Cold Air Replacement

This filter offers high flow and low restriction, better throttle response, and increased filtration and horsepower. Filters are made of a Dry Media material and are washable and reusable. Do not oil dry media filters.

- 77070015** Air Filter, Cold Air Intake Replacement, Dry Media, Used to Service Kit 77060012AB
- 77070010** Air Filter, Cold Air Intake Replacement, Dry Media, Used to Service Kits 77060003AB, 77060006AB, 77060010AB, 77060011AB, 77070008
- 77070012** Air Filter, Cold Air Intake Replacement, Dry Media, Used to Service Kits 77060005AB, 77060009AB, 77070004, 77070006
- 77070013** Air Filter, Cold Air Intake Replacement, Dry Media, Used to Service Kits 77060007, 77060013AB, 77060021, 77060080
- 77070014** Air Filter, Cold Air Intake Replacement, Dry Media, Used to Service Kits 77060008, 77060020AB
- 77070018** Air Filter, Cold Air Intake Replacement, Dry Media, Used to Service Kits 77060081, 77070002
- 77070017** Air Filter, Cold Air Intake Replacement, Dry Media, Used to service P4510921AB

#### B. Air Filters- O.E. Performance Replacement- Jeep

Constructed with factory tight seals, engineering-level polyurethane, deep four-ply pleats of oiled cotton gauze and two layers of aluminum screen. This filter offers high flow and low restriction, better throttle response, and increased filtration and horsepower. Filters are washable and reusable and come pre-oiled.

- P4510474** Air Filter, High Flow, O. E. Replacement, 1991-01 4.0L Cherokee
- P4510473** Air Filter, High Flow, O. E. Replacement, 1997-03 4.0L Wrangler
- P4510475** Air Filter, High Flow, O. E. Replacement, 1999-04 4.7L Grand Cherokee
- P5153573** Air Filter, High Flow, O. E. Replacement, 2007-09 Compass/Patriot/Caliber, 2.4L/2.0L Non-Turbo
- P5155085** Air Filter, High Flow, O. E. Replacement, 2007-09 Wrangler 3.8L, 2002-07 Liberty 3.7L
- P4510472** Air Filter, High Flow, O. E. Replacement, Oiled, 2005-10 3.5L Magnum/300/Charger/Challenger, 2002-03 3.7L Liberty



A.

---



B.

---

**AIR SYSTEMS**

**A. Air Filters- O.E. Performance Replacement-Truck**

Constructed with factory tight seals, engineering-level polyurethane, deep four-ply pleats of oiled cotton gauze and two layers of aluminum screen. This filter offers high flow and low restriction, better throttle response, and increased filtration and horsepower. Filters are washable and reusable and come pre-oiled.

- P4510469** Air Filter, High Flow, O. E. Replacement, 1994-01 5.2L/5.9L Ram
- P4510467** Air Filter, High Flow, O. E. Replacement, 1997-99 5.2L/5.9L Dakota/Durango
- P4510466** Air Filter, High Flow, O. E. Replacement, 1999-03 4.7L Dakota/Durango
- P4510468** Air Filter, High Flow, O. E. Replacement, 2000-03 5.9L Dakota/Durango
- P5153573** Air Filter, High Flow, O. E. Replacement, 2007-09 Compass/Patriot/Caliber, 2.4L/2.0L Non-Turbo

**B. Air Filter Service Kit**

Services all Mopar oiled filters that are both washable and reusable.

- P5153376** Air Filter Service Kit, For "Oiled" Air Filters

**C. Ram Air Package**

Creates a ram air effect at speeds of 40+ mph. Integrates seamlessly to the underside of an SRT10 Ram Air Hood to route cool outside air into the included Performance Cold Air Intake System. Constructed from lightweight material and installs directly with minor modifications. CARB EO#D-265-23.

- P4510921AB** Ram Air Induction System, 2004-05 Ram SRT10

**D. Ram Air Duct**

This duct routes all the cool air your Ram can pull in through the SRT Ram Hood (82208702) over to the Cold Air Intake System (77060005) for maximum performance gains.

- P5153307** Ram Air Duct, 2003-08 Ram 5.7L

**E. Snorkels**

Snorkel systems allow your engine to breathe in heavy dust or various water crossings. Attaches to the vehicle using existing factory hardware. Combine with the Heat Reduction Hood (P5155351) for a complete bolt-on package.

- <sup>1</sup> **P5155330** Snorkel, W/ Air Ram, 2007-09 Wrangler
- <sup>1</sup> **P5155422** Snorkel, W/ Pre-Filter, 2007-09 Wrangler

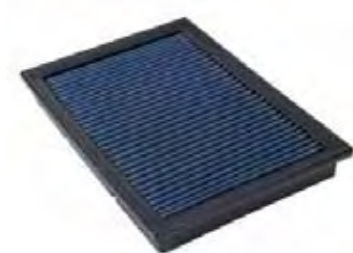

A.



B.



C.



D.



E. P5155330



E. P5155422

Questions? Call the Mopar Direct Connection Techline at 1-888-528-HEMI (4364)

<sup>1</sup> Not legal on pollution-controlled vehicles or vehicles registered for highway use.

## JEEP/RAM

### EXHAUST SYSTEMS

#### A. Exhaust Headers

Bolt on a set of Mopar Exhaust Headers and feel the power. Manufactured from heavy 14-gauge tubing with 3/8" thick flanges. True mandrel bends and triple nickel-chrome finish make these headers the most durable on the market. Each header is engineered to achieve maximum flow through minimum back pressure, resulting in increased horsepower and torque. Kits include all necessary installation hardware. No welding required.

- <sup>1</sup> P4510873 Header, 2003-05 Ram 1500, 5.7L, Automatic Transmission, 4 Wheel Drive
- <sup>1</sup> P4510280 Header, 2003-05 Ram, 5.7L, Automatic Transmission, 2 Wheel Drive
- <sup>1</sup> P5153566 Header, 2007-09 Compass/Patriot/Caliber, FWD, Non-Turbo

Note: For P4510280, Mopar Y-Pipe Package (P4510829) must be used on 2004 models. It is recommended that Y-Pipe Package (P4510364) be used with 2003 models.

#### B. Exhaust Header Y-Pipe Packages

These high-flow, low-restriction Y-pipe Exhaust Header Packages will boost horsepower and torque by 10%. They feature T304 stainless steel construction and include dual high-flow catalytic converters, as well as dual 2.5" into "two-into-one" Y-connections and 0.065" thick walls. Packages use all factory sensors and require no welding for a direct, bolt-on fit. Kit includes all hardware, flanges and stainless steel band clamps necessary for installation.

- <sup>1</sup> P4510364 Exhaust Y-Pipe, 2003 5.7L Hemi Ram, 1500, 2WD, Automatic Transmission
- <sup>1</sup> P4510872 Exhaust Y-Pipe, 2003 5.7L Hemi Ram, 1500, 4WD, Automatic Transmission
- <sup>1</sup> P4510829 Exhaust Y-Pipe, 2004-05 5.7L Hemi Ram 1500, 2WD, Automatic Transmission

#### C. Exhaust Headers- Ram SRT10

Headers with Mid-Pipes, Race, Fits Standard and Extended Cab. Eliminates catalysis. Recommend engine control modules: 2004 - P4510918, 2005- P5153335, 2006-P5153591. Manual and Automatic Transmission, 2004-06 Ram SRT10.

- <sup>1</sup> P5153168 Headers, 2004-06, Ram SRT10



A. P4510280



A. P5153566



B.



C.

**EXHAUST SYSTEMS**

**A. Cat-Back Exhaust Systems - Jeep**

These Cat-back Exhaust Systems feature T304 stainless steel construction (aircraft quality) with mandrel-bent tubing, stainless band Torca clamps, muffler, and polished tips. These free-flow systems provide a horsepower and torque gain, improved fuel economy and a deeper tone.

- <sup>1</sup> **P5007792** Cat-Back Exhaust System, Dual Rear Exit, 2002-05 Liberty 3.7L
- <sup>1</sup> **P5155035** Cat-Back Exhaust System, Dual Rear Exit, Square Tips, 2.5" Pipe, 2009 3.7L Liberty
- <sup>1</sup> **P4510858** Cat-Back Exhaust System, Rear Exit, 2.25" Pipe, 2004 Grand Cherokee 4.0L, 4.7L, 2/4 Wheel Drive
- <sup>1</sup> **P4510857** Cat-Back Exhaust System, Rear Exit, 2004-06 Wrangler, 4.0L
- <sup>1</sup> **P5155114** Cat Back Exhaust System, Single Exit With Square Tip, 2007-09 Compass/Patriot, AWD, 2.0L/2.4L
- <sup>1</sup> **P5153589** Cat-Back Exhaust System, Rear Exit, 2.5" Pipe, 2005 - 08 Commander, 5.7L, 2/4 Wheel Drive
- <sup>1</sup> **P5155113** Cat Back Exhaust System, Single Exit With Square Tip, 2007-09 Compass/Patriot, FWD, 2.0L/2.4L
- <sup>1</sup> **P5153858** Cat Back Exhaust System, Single Outlet, 2007-09 Wrangler 3.8L, 2/4 Door
- <sup>1</sup> **P5153364** Cat-Back Exhaust System, Rear Exit, 2.5" Pipe, 2005-08 Grand Cherokee, 5.7L, 2/4 Wheel Drive



A. P5153364



A. P5155113



A. P5153589

**B. Cat-Back Exhaust Systems- Jeep SRT8**

Cat-back exhaust systems feature RSC no-drone technology, with 2.75" 304L stainless steel mandrel bent tubing, stainless (Torca) clamps and polished 4" Pro-Series tips. The patented Power-Pulse RSC™ muffler design delivers the throaty exhaust tones that define your Hemi-Powered ride on the open road.

- <sup>1</sup> **P5153453** Cat-Back Exhaust System, Dual Center Rear Exit, 2006-2009 Grand Cherokee SRT8, 6.1L



B. P5153453

Questions? Call the Mopar Direct Connection Techline at 1-888-528-HEMI (4364)

<sup>1</sup> Not legal on pollution-controlled vehicles or vehicles registered for highway use.

EXHAUST SYSTEMS

A. Cat-Back Exhaust Systems - Truck

These bolt-on systems feature heavy-wall 304 Stainless Steel tubing with true mandrel bends, allowing for maximum flow and minimum back pressure. Low restriction, aluminized case, and a flow-through muffler with a 3.0" core produce a deep mellow exhaust note. Includes straight through flow muffler.

- <sup>1</sup> P4510607 Cat-Back Exhaust System, Rear Exit, 3.0" Pipe, 2004-08 Durango, 4.7/5.7L, 2/4 Wheel Drive
- <sup>1</sup> P5153365 Cat-Back Exhaust System, 45 Degree Passenger Side Exit, 2.50" Pipe, 2005-08 Dakota 4.7L, 2/4 Wheel Drive
- <sup>1</sup> P5155280 Cat Back Exhaust System, Dual Rear Exit, Round Chrome Tips, 2009 Ram 5.7L (With Bumper Cut-Outs), 6/8" Bed, 4WD
- <sup>1</sup> P5153641 Cat-Back Exhaust System, 45 Degree Passenger Exit in Front of Rear Wheels, 2.5" Pipe, 2006-08 Ram 1500, 5.7L, Crew Cab, Short Bed, 2/4 Wheel Drive
- <sup>1</sup> P5153640 Cat-Back Exhaust System, 45 Degree Passenger Exit in Front of Rear Wheels, 2.5" Pipe, 2006-08 Ram 1500, 5.7L, Regular Cab, Short Bed, 2/4 Wheel Drive
- <sup>1</sup> P5153696 Cat-Back Exhaust System, 90 Degree Passenger and Driver Exit, 2.5" Pipe, 2006-08 Ram 1500, 5.7L, Crew Cab, Short Bed, 2/4 Wheel Drive
- <sup>1</sup> P5153695 Cat-Back Exhaust System, 90 Degree Passenger and Driver Exit, 2.5" Pipe, 2006-08 Ram 1500, 5.7L, Regular Cab, Short Bed, 2/4 Wheel Drive
- <sup>1</sup> P5153674 Cat-Back Exhaust System, Rear Exit, 2.25" Pipe, 2006- 08 Ram 1500, 5.7L, Regular Cab Short Bed, 2/4 Wheel Drive
- <sup>1</sup> P5155110 Cat-Back Exhaust System, Single Rear Exit With Dual Square Tips, 2.5" Pipe, 2007-09 Nitro, 4.0L, V6
- <sup>1</sup> P5155111 Cat Back Exhaust System, Single Rear Exit With Dual Square Tips, 2.5" Pipe, 2007-09 Nitro, 3.7L
- <sup>1</sup> P5153473 Cat-Back Exhaust System, Rear Exit, 2.25" Pipe, 2006-08 Ram 1500, 5.7L, Crew Cab, Short Bed, 2/4 Wheel Drive
- <sup>1</sup> P5007851 Cat-Back Exhaust System, 45 Degree Passenger and Driver Exit, 2.5 pipe, 2002-05 Ram 1500 Regular/ Extended/ Crew Cab, Short Bed, 2/4 Wheel Drive
- <sup>1</sup> P4510464 Cat-Back Exhaust System, 45 Degree Passenger and Driver Exit, 2.5" Pipe, 2003 1500 Ram, Regular/Extended/Crew Cab, Short Bed, 2 Wheel Drive
- <sup>1</sup> P4510465 Cat-Back Exhaust System, 45 Degree Passenger and Driver Exit, 2.5" Pipe, 2003-05 Ram 2500, 5.7L, Regular/Extended/Crew Cab, Short Bed, 2/4 Wheel Drive
- <sup>1</sup> P4510648 Cat-Back Exhaust System, 45 Degree Passenger and Driver exit, 2.50" pipe, 2004 - 05 Ram 1500 Hemi 5.7L, Regular/Crew Cab, Short Bed, 2/4 Wheel Drive.
- <sup>1</sup> P4510856 Cat-Back Exhaust System, Rear Exit, 2003-05 Ram SRT10, 8.3L, Regular Cab, Short Bed
- <sup>1</sup> P5153639 Cat-Back Exhaust System, Rear Exit, 2006 Ram SRT 10, 8.3L, Regular/Crew Cab, Short Bed



A. P4510464



A. P5007851



A. P5153640



A. P5153674



A. P5153641



A. P5153695



## OILING COMPONENTS

### A. Oil Pump-High Volume

When the going gets tough, you'll want to be sure and supply as much oil to your engine as possible. This high-volume Oil Pump will do the job and take the most severe punishment. P4529241 requires pan rework for 4.0L applications.

<sup>1</sup> P4529241 Oil Pump, 4.0L/4.2L Jeep Vehicles

### B. Oil Pump-Heavy Duty

<sup>1</sup> P4529227 Oil Pump, Heavy Duty, 4.0L Jeep, 1962 and Up

### C. Oil Pump - Performance

This high-performance, high-output Oil Pump assembly provides a 25% increase in oil volume. Ideal replacement for stock pump in high performance applications.

<sup>1</sup> P4286740 Oil Pump, 225 Slant 6



A.



B.



C. P4286740

Questions? Call the Mopar Direct Connection Techline at 1-888-528-HEMI (4364)

<sup>1</sup> Not legal on pollution-controlled vehicles or vehicles registered for highway use.

## JEEP/RAM

### SUSPENSION UPGRADES AND COMPONENTS

#### A. Lift Kits- JK (4WD)

##### Short Arm Lift Kits: 2" and 4"

These Mopar lifts offer exceptional ride comfort and control, on-road or off. Both lift heights use the same basic components, except for coil springs, and yield all the suspension travel the factory JK driveline offers. Coil spring rate is wheelbase-specific (2 or 4-door), plus two Mopar shock absorber options allow you to tailor the kit to your performance aspirations. Both kits also include a replacement high-clearance, high capacity hydraulic steering stabilizer kit (white color). The 2" lift is ideal for 33" to 35" diameter tires; the 4" is best suited for 35" to 37" tires. Note that Rubicons (with 2" or 4" Lifts) require the Front Stabilizer Bar Link Kit (P5155512).

##### Long Arm Lift Kits: 4.5"

The ultimate off-road performer. Mopar's Long Arm kit provides optimal suspension travel by using longer, high-articulation axle-to-frame link arms. Dampening is handled by Bilstein high-pressure monotube gas shocks. This kit contains a vast array of components, including replacement front / rear driveshafts. Best suited for 37" diameter tires.

##### Shock Options:

Performance shock is a twin-tube, high capacity hydraulic shock that features ten-stage velocity sensitive valving. White enamel finish; includes black boot.

Mopar's premium shock, jointly tuned with Bilstein, allows you to realize the most performance gain. The seamless monotube body contains a patented piston design and a high-pressure gas charge to quickly dissipate heat and minimize shock fade. Silver Zinc plated finish; includes black boot.

- <sup>1</sup> P5155207 Lift Kit, 2" Lift, w/ Bilstein Shocks, 2007-11 Wrangler (JK), 4-Door
- <sup>1</sup> P5155789 Lift Kit, 2" Lift, w/ Performance Shocks, 2007-11 Wrangler (JK), 4-Door
- <sup>1</sup> P5155208 Lift Kit, 2" Lift, w/ Bilstein Shocks, 2007-11 Wrangler (JK), 2-Door
- <sup>1</sup> P5155790 Lift Kit, 2" Lift, w/ Performance Shocks, 2007-11 Wrangler (JK) 2-Door
- <sup>1</sup> P5155404AB Lift Kit, 4" Lift, Short Arm, w/ Bilstein Shocks, 2007-11 Wrangler (JK), 4-Door
- <sup>1</sup> P5155403AB Lift Kit, 4" Lift, Short Arm w/ Performance Shocks, 2007-11 Wrangler (JK), 4-Door
- <sup>1</sup> P5155075 Lift Kit, 4.5" Lift, Long Arm w/ Bilstein Shocks, 2007-11 Wrangler (JK), 4-Door
- <sup>1</sup> P5155512 Stabilizer Bar Link Kit, Front, Use with 2" and 4" Lift Kits, 2007-11 Wrangler (JK)



A. P5155075



A. P5155207



A. P5155404AB

## SUSPENSION UPGRADES AND COMPONENTS

### Lift Kits- JK (4WD)

**WARNING:** Lift Kits alter vehicle properties and affect handling. Lift kits are intended to be used for off-road driving only. Your kit will come with more detailed instructions and warnings. Contact the Mopar Direct Connection Tech Line (888-528-4364) to obtain a copy.

**NOTE:** Vehicle RPM and speedometer readings are based on the stock vehicle's tire and wheel combinations. Installing larger wheels and tires with your Mopar Performance lift kit could result in incorrect RPM, speedometer and odometer readings.

**WARRANTY:** Lift Kits work with all vehicle systems including the Electronic Stability Program, and are covered (except P5155075) by a Limited Lifetime Warranty. The warrantor is the Lift Kit manufacturer, not Mopar, Chrysler Group LLC, or the dealership selling the product. Contact the Mopar Direct Connection Tech Line (888-528-4364) for warranty details and installation instructions.

## JEEP/RAM

### SUSPENSION UPGRADES AND COMPONENTS

#### A. Lift Kits- WK/XK (4WD)

The front lift is accomplished with strut lowers; rear lift via new coil springs. Thin preload plates install on top of the springs to boost spring rate slightly and offset the increased load / leverage generated by heavier and wider tires and wheels. The lower control arms and differential are relocated via bracketry then new steering knuckles span the increased distance from the relocated lower control arms to the upper arms, which remain in the stock location. Bracketry relocates the affected rear suspension components. Lift Kits include a plug-in module to ensure functionality of Jeep's Electronic Stability Program.

<sup>1</sup> P5155383 Lift Kit, 4" Lift w/ Shocks, 2005-07 Grand Cherokee/Commander (WK/XK)

<sup>1</sup> P5155384 Lift Kit, 4" Lift w/ Shocks, 2008-10 Grand Cherokee/Commander (WK/XK)

See chart for additional information.

**WARNING:** Lift Kits alter vehicle properties and affect handling. Lift kits are intended to be used for off-road driving only. Your kit will come with more detailed instructions and warnings. Contact the Mopar Direct Connection Tech Line (888-528-4364) to obtain a copy.

**NOTE:** Vehicle RPM and speedometer readings are based on the stock vehicle's tire and wheel combinations. Installing larger wheels and tires with your Mopar Performance lift kit could result in incorrect RPM, speedometer and odometer readings.

**WARRANTY:** Lift Kits work with all vehicle systems including the Electronic Stability Program, and are covered (except P5155075) by a Limited Lifetime Warranty. The warrantor is the Lift Kit manufacturer, not Mopar, Chrysler Group LLC, or the dealership selling the product. Contact the Mopar Direct Connection Tech Line (888-528-4364) for warranty details and installation instructions.



A. P5155384

#### JEEP LIFT KITS

Part Number	Description	Lift Height	Model*	Series	Engine	Bilstein Shocks	Performance Shocks	Model Year In	Model Year Out
P5155207	Lift Kit	2"	JK	Wrangler	All	X		2007	2011
P5155789	Lift Kit	2"	JK	Wrangler	All		X	2007	2011
P5155208	Lift Kit	2"	JK	Wrangler	All	X		2007	2011
P5155790	Lift Kit	2"	JK	Wrangler	All		X	2007	2011
P5155404AB	Lift Kit- Short Arm	4"	JK	Wrangler	All	X		2007	2011
P5155403AB	Lift Kit- Short Arm	4"	JK	Wrangler	All		X	2007	2011
P5155075	Lift Kit- Long Arm	4.5"	JK	Wrangler	3.8	X		2007	2011
P5155383	Lift Kit	4"	WK/XK	Grd.Cherokee/Commander	All		X	2005	2007
P5155384	Lift Kit	4"	WK/XK	Grd.Cherokee/Commander	All		X	2008	2010

\* Rubicon models require Front Stabilizer Bar Link Kit P5155512

## SUSPENSION UPGRADES AND COMPONENTS

### A. Lift Kits- Ram 1500 (4WD)

Lift Kits 2" (excluding TRX4)

Fits Crew, Quad and Regular cabs, and provides lift for up to 35" diameter tires. Front lift is via replacement Premium Performance Bilstein gas struts; new dual Rate coil springs provide rear lift. Also includes components to address rear stabilizer bar, brake hose length and compression travel, as well as Premium Performance Bilstein rear shocks. Compatible with all vehicle systems, including Electronic Stability Program.

Lift Kits 4" (excluding TRX4) and Lift Kits 3" (TRX4 models)

Fits Crew, Quad and Regular cabs, and provides lift for up to 37" diameter tires while retaining factory turning radius. Lift kits for both the standard DS and TRX4 models contain the same basic components; there are only a few minor differences. The TRX4 factory ride height is approximately 1" taller than the standard DS, so ride height of a 3" Mopar lift-equipped TRX4 is as tall as a 4" Mopar lift-equipped DS. Compatible with all vehicle systems, including Electronic Stability Program.

Shock Options:

Performance shock is a twin-tube, high capacity hydraulic shock that features ten-stage velocity sensitive valving. White enamel finish; includes black boot.

Mopar's premium shock, jointly tuned with Bilstein, allows you to realize the most performance gain. The seamless monolube body contains a patented piston design and a high-pressure gas charge to quickly dissipate heat and minimize shock fade. Silver Zinc plated finish; includes black boot.

- <sup>1</sup> P5155258 Lift Kit, Pre-Runner, Stage 1, 2009-11 Ram (DS), N/A for TRX
- <sup>1</sup> P5155662 Lift Kit, Pre-Runner, Stage 2, 2009-11 Ram (DS), N/A for TRX
- <sup>1</sup> P5155797 Lift Kit, 2" Lift, w/ Bilstein Struts and Rear Shocks, 2009-11 Ram (DS) 1500, N/A for TRX
- <sup>1</sup> P5155465 Lift Kit, 3" Lift w/ Bilstein Struts and Rear Shocks, 2009-11 Ram (DS) 1500, TRX Only
- <sup>1</sup> P5155466 Lift Kit, 3" Lift, w/ Strut Spacers and Performance Rear Shocks, 2009-11 Ram (DS) 1500, TRX Only
- <sup>1</sup> P5155212 Lift Kit, 4" Lift, w/Bilstein Struts and Rear Shocks, 2009-11 Ram (DS) 1500, N/A for TRX
- <sup>1</sup> P5155393 Lift Kit, 4." Lift w/ Strut Spacers and Performance Rear Shocks, 2009-11 Ram (DS) 1500, N/A for TRX

### B. Lowering Kit- Ram DR (2WD)

- <sup>1</sup> P5155066 Lowering Kit, Includes Springs, Shocks and Axle Flip Kit, Front= 1.50" and Rear= 4.30", 2006-08 Ram, 2WD, SWB



A. P5155797



A. P5155393



A. P5155212



B. P5155066

### RAM TRUCK 1500 LIFT KITS

Part Number	Description	Lift Height	Model	Series	Engine	Bilstein Shocks	Performance Shocks	Model Year In	Model Year Out
P5155391AB	Leveling Kit (Front)	2"	DR	1500	All			2006	2008
P5155388AB	Leveling Kit (Front)	2"	DR	1500	All			2002	2005
P5155387AB	Leveling Kit (Front)	2"	BE/BR	1500	All			1994	2001
P5155797	Lift Kit	2"	DS	1500	All	X		2009	2011
P5155258	Pre-Runner Stage 1	3"	DS	1500	All	X		2009	2011
P5155662	Pre-Runner Stage 2	3"	DS	1500	All	X		2009	2011
P5155465	Lift Kit	3"	DS (TRX)	1500	All	X		2009	2011
P5155466	Lift Kit	3"	DS (TRX)	1500	All		X	2009	2011
P5155212	Lift Kit	4"	DS	1500	All	X		2009	2011
P5155393	Lift Kit	4"	DS	1500	All		X	2009	2011

Questions? Call the Mopar Direct Connection Techline at 1-888-528-HEMI (4364)

<sup>1</sup> Not legal on pollution-controlled vehicles or vehicles registered for highway use.

JEEP/RAM

## SUSPENSION UPGRADES AND COMPONENTS

### Lift Kits- Ram 1500 (4WD)

See chart for additional information.

**WARNING:** Lift Kits alter vehicle properties and affect handling. Lift kits are intended to be used for off-road driving only. Your kit will come with more detailed instructions and warnings. Contact the Mopar Direct Connection Tech Line (888-528-4364) to obtain a copy.

**NOTE:** Vehicle RPM and speedometer readings are based on the stock vehicle's tire and wheel combinations. Installing larger wheels and tires with your Mopar Performance lift kit could result in incorrect RPM, speedometer and odometer readings.

**WARRANTY:** Lift Kits work with all vehicle systems including the Electronic Stability Program, and are covered (except P5155075) by a Limited Lifetime Warranty. The warrantor is the Lift Kit manufacturer, not Mopar, Chrysler Group LLC, or the dealership selling the product. Contact the Mopar Direct Connection Tech Line (888-528-4364) for warranty details and installation instructions.

## SUSPENSION UPGRADES AND COMPONENTS

### A. Leveling Kits- Ram (4WD)

Fits all cab and bed configurations, including Duallies (except TRX4 models). Leveling kits raise the front of the Ram, and eliminate the factory "nose low" rake, to make room for tires 1" to 2" taller than stock. For 2500 / 3500 models, a 2" rear block kit is offered for those who wish to retain the factory rake because of load hauling and towing.

#### LEVELING KIT FEATURES:

- Front lift, depending on application, is via either coil spacers, strut spacers or new torsion bar keys, so factory springs are retained and ride quality is unaffected.
- Very economical.
- Can use factory wheels and allows clearance for tires 1" to 2" taller than stock.
- Easy installation - Most kits install in no more than a couple of hours. Front end realignment is required.
- Ram 2500/3500 rear block kit (#P5155452) includes two U-bolt sets to applicate both axle types found in these pickups, plus brackets to prevent suspension over-compression.

- <sup>1</sup> P5155394 Leveling Kit, 2" Lift, Front, 1994-11 Ram (BE/BR/DH/DJ/DR/D1/D2) 2500/3500
- <sup>1</sup> P5155452 Lift Kit, 2" Block Lift, Rear, 2003-11 Ram (DR/DH/DJ/ D1/ D2) 2500/3500
- <sup>1</sup> P5155388AB Leveling Kit, 2.0" Lift, Front, 2002-05 Ram (DR) 1500, 4WD
- <sup>1</sup> P5155387AB Leveling Kit, 2.5" Lift, Front, 1994-01 Ram (BR/BE) 1500, 4WD
- <sup>1</sup> P5155391AB Leveling Kit, 2.5" Lift, Front, 2006-08 Ram (DR) 1500, 4WD

**WARNING:** Lift Kits alter vehicle properties and effect handling. Lift kits are intended to be used for off-road driving only. Your kit will come with more detailed instructions and warnings. Contact the Mopar Direct Connection Tech line (888-528-4364) to obtain a copy.

**NOTE:** Vehicle RPM and speedometer readings are based on the stock vehicle's tire and wheel combinations. Installing larger wheels and tires with your Mopar Performance lift kit could result in incorrect RPM, speedometer and odometer readings.

**WARRANTY:** Lift Kits work with all vehicle systems including the Electronic Stability Program, and are covered (except P5155075) by a Limited Lifetime Warranty. The warrantor is the Lift Kit manufacturer, not Mopar, Chrysler LLC, or the dealership selling the product. Refer to [www.Mopar.com](http://www.Mopar.com) for warranty details and installation instruction downloads.



A. P5155394



A. P5155452



A. P5155387AB



A. P5155391AB

Questions? Call the Mopar Direct Connection Techline at 1-888-528-HEMI (4364)

<sup>1</sup> Not legal on pollution-controlled vehicles or vehicles registered for highway use.

## JEEP/RAM

### SUSPENSION UPGRADES AND COMPONENTS

#### A. Lift Kits- Ram 2500/3500 (4WD)

New coil springs specifically rated for engine type, are matched with your choice of Performance shocks (gas front / hydraulic rear) in a white enamel finish, or our Bilstein monotube high-pressure gas shocks that feature a silver Zinc finish. Includes a dual steering stabilizer kit with cylinders matched to your choice of lift kit shocks.

##### Shock Options:

Performance shock is a twin-tube, high capacity hydraulic shock that features ten-stage velocity sensitive valving. White enamel finish; includes black boot.

Mopar's premium shock, jointly tuned with Bilstein, allows you to realize the most performance gain. The seamless monotube body contains a patented piston design and a high-pressure gas charge to quickly dissipate heat and minimize shock fade. Silver Zinc plated finish; includes black boot.

- <sup>1</sup> P5155496 Lift Kit, 4" Lift, w/ Bilstein Shocks, 2010-11 Ram (DJ/D2) 2500/3500, 6.7L
- <sup>1</sup> P5155497 Lift Kit, 4" Lift, w/ Performance Shocks, 2010-11 Ram (DJ/D2) 2500/3500, 6.7L
- <sup>1</sup> P5155498 Lift Kit, 4" Lift, w/ Bilstein Shocks, 2010-11 Ram (DJ/D2) 2500/3500, 5.7L
- <sup>1</sup> P5155499 Lift Kit, 4" Lift, w/ Performance Shocks, 2010-11 Ram (DJ/D2) 2500/3500, 5.7L
- <sup>1</sup> P5155398AB Lift Kit, 4" Lift, w/ Bilstein Shocks, 2009 Ram (DH/D1) 2500/3500, 6.7L
- <sup>1</sup> P5155397AB Lift Kit, 4" Lift, w/ Performance Shocks, 2009 Ram (DH/D1) 2500/3500, 6.7L
- <sup>1</sup> P5155402AB Lift Kit, 4" Lift, w/ Bilstein Shocks, 2009 Ram (DH/D1) 2500/3500, 5.7L
- <sup>1</sup> P5155401AB Lift Kit, 4" Lift, w/ Performance Shocks, 2009 Ram (DH/D1) 2500/3500, 5.7L
- <sup>1</sup> P5155641 Lift Kit, 4" Lift, w/ Bilstein Shocks, 2008 Ram (DH/D1) 2500/3500, 6.7L
- <sup>1</sup> P5155640 Lift Kit, 4" Lift, w/ Performance Shocks, 2008 Ram (DH/D1) 2500/3500, 6.7L
- <sup>1</sup> P5155643 Lift Kit, 4" Lift, w/ Bilstein Shocks, 2008 Ram (DH/D1) 2500/3500, 5.7L
- <sup>1</sup> P5155642 Lift Kit, 4" Lift, w/ Performance Shocks, 2008 Ram (DH/D1) 2500/3500, 5.7L
- <sup>1</sup> P5155396AB Lift Kit, 4" Lift, w/ Bilstein Shocks, 2003-08 Ram (DR/DH/D1) 2500/3500, 5.9L/8.0L/6.7L
- <sup>1</sup> P5155395AB Lift Kit, 4" Lift, w/ Performance Shocks, 2003-08 Ram (DR/DH/D1) 2500/3500, 5.9L/8.0L/6.7L
- <sup>1</sup> P5155400AB Lift Kit, 4" Lift, w/ Bilstein Shocks, 2003-08 Ram (DH/DR/D1) 2500/3500, 5.7L
- <sup>1</sup> P5155399AB Lift Kit, 4" Lift, w/ Performance Shocks, 2003-08 Ram (DH/DR/D1) 2500/3500, 5.7L

#### B. Prop Shafts- Jeep Lift Kits

- <sup>1</sup> P5155119 Prop Shaft, Front, 4.5" Lift Kit Service Part, 2007-11 Wrangler, 4-Door, 4WD
- <sup>1</sup> P5155120 Prop Shaft, Rear, 4.5" Lift Kit Service Part, 2007-11 Wrangler, 2-Door, 4WD
- <sup>1</sup> P5155118 Prop Shaft, Rear, 4.5" Lift Kit Service Part, 2007-11 Wrangler, 4-Door, 4WD



A. P5155496



A. P5155497



B. P5155118



## SUSPENSION UPGRADES AND COMPONENTS

### Lift Kits- Ram 2500/3500 (4WD)

See chart for additional information.

**WARNING:** Lift Kits alter vehicle properties and affect handling. Lift kits are intended to be used for off-road driving only. Your kit will come with more detailed instructions and warnings. Contact the Mopar Direct Connection Tech Line (888-528-4364) to obtain a copy.

**NOTE:** Vehicle RPM and speedometer readings are based on the stock vehicle's tire and wheel combinations. Installing larger wheels and tires with your Mopar Performance lift kit could result in incorrect RPM, speedometer and odometer readings.

**WARRANTY:** Lift Kits work with all vehicle systems including the Electronic Stability Program, and are covered (except P5155075) by a Limited Lifetime Warranty. The warrantor is the Lift Kit manufacturer, not Mopar, Chrysler Group LLC, or the dealership selling the product. Contact the Mopar Direct Connection Tech Line (888-528-4364) for warranty details and installation instructions.

# JEEP/RAM

## SUSPENSION UPGRADES AND COMPONENTS

### A. Shocks- Jeep Lift Kits

These are the same Shocks packaged with Mopar's lift kits. Order when upgrading from Performance series to Premium Bilstein, or when needing service replacements. The Performance shock is a twin-tube, high capacity hydraulic shock that features ten-stage velocity sensitive valving. White enamel finish; includes black boot.

Mopar's premium shock, jointly tuned with Bilstein, allows you to realize the most performance gain. The seamless monotube body contains a patented piston design and a high-pressure gas charge to quickly dissipate heat and minimize shock fade. Silver Zinc plated finish; includes black boot.

- <sup>1</sup> P5155116 Shock, Front, Bilstein, 2007-11 Wrangler (JK), 4.5" Lift Kits
- <sup>1</sup> P5155117 Shock, Rear, Bilstein, 2007-11 Wrangler (JK), 4.5" Lift Kits
- <sup>1</sup> P5155262 Shock, Front, Bilstein, Replacement/ Upgrade for 2007-11 Wrangler (JK), 2" and 4" Lift Kits
- <sup>1</sup> P5155263 Shock, Rear, Bilstein, Replacement/ Upgrade for 2007-11 Wrangler (JK), 2" and 4" Lift Kits
- <sup>1</sup> P5155804 Shock, Front, Performance, Replacement for 2007-11 Wrangler (JK), 2" and 4" Lift Kits
- <sup>1</sup> P5155805 Shock, Rear, Performance, Replacement for 2007-11 Wrangler (JK), 2" and 4" Lift Kits



A. P5155117



A. P5155116

### B. Steering Stabilizers

These are some of the same kits included with Mopar's Lift Kits. Fits trucks from stock height up to 4" of lift. Fits Jeep (JK) 2" and 4" lift kits. Available with Performance hydraulic cylinders, or Premium Bilstein gas cylinders.

- P5155413 Stabilizer Kit, Dual Steering, Bilstein Cylinders, 2003-08 (thru to 03/01/08) Ram 2500/3500, 4WD
- P5155415 Stabilizer Kit, Dual Steering, Bilstein Cylinders, 2008 (from 03/01/08) -11 Ram 2500/3500, 4WD
- P5155412 Stabilizer Kit, Dual Steering, Performance Cylinders, 2003-08 (thru 03/01/08) Ram 2500/3500, 4WD
- P5155414 Stabilizer Kit, Dual Steering, Performance Cylinders, 2008 (from 03/01/08) -11 Ram 2500/3500, 4WD
- P5155264 Stabilizer Kit, Steering, High-Clearance, High-Capacity, 2007-11 Wrangler (JK), 2" and 4" Lift Kits



B. P5155264



B. P5155415

### C. Stabilizer Bar Disconnects- Jeep Lift Kits

Quick-Disconnects allow a considerable amount of increased front wheel travel while off-roading. With Mopar's Quick-Disconnects, simply pull the pin, unscrew the coupler, pivot it upward, strap it up and go! Do not operate the vehicle on-road with the stabilizer bar disconnected. Note that Quick-Disconnects are not needed on Rubicon models since they are factory-equipped with electronic disconnects.

- <sup>1</sup> P5155419 Stabilizer Bar Quick-Disconnects, Front, Use with 2007-11 Wrangler (JK) 2" and 4" Lift Kits



C. P5155419

## SUSPENSION UPGRADES AND COMPONENTS

### A. Axle-to-Frame Links, High-Articulation

Mopar's replacement lower link arms coax the remaining twist out of your Mopar 2" or 4" lift kit. The tubular links incorporate a male / female threaded end that reduces bind during articulation. The threaded feature also allows additional driveline and steering alignment range. A combination of greasable Urethane bushings (axle end), and factory type, press-fit rubber bushings (frame end) provides superior durability, flexibility and service life compared to most other replacement links. This bushing combination also results in quieter operation, and less shock load transmission. Front Links feature an upwards bend for improved ground clearance.

- <sup>1</sup> P5155420 Axle-to-Frame Lower Links, Front, High-Articulation, Use with 2007-11 Wrangler (JK) 2" and 4" Lift Kits, Pair
- <sup>1</sup> P5155421 Axle-to-Frame Lower Links, Rear, High-Articulation, Use with 2007-11 Wrangler (JK) 2" and 4" Lift Kits, Pair



A. P5155420

A. P5155421

### B. Traction Bars- 4" Lift Kits

Designed to combat torque loads and the resulting axle wrap-up. Effective axle-wrap control starts with proper geometry. Leaf springs become longer as they compress, so in order to prevent suspension bind the Traction Bars' arc of travel must be in sync with the rear spring's movement. Mopar Traction Bars also incorporate a threaded swivel-end (at the frame mount) to prevent destructive torsional loads from stressing the truck's frame. Features a tubular main beam brace with a brushed stainless steel insert and Mopar logo.

- <sup>1</sup> P5155416 Traction Bars, 2003-11 Ram 2500/3500, Quad Cab, Short Bed, 4" Mopar Lift Kits Only
- <sup>1</sup> P5155417 Traction Bars, 2003-11 Ram 2500/3500, Quad/ Mega Cab, Long Bed, 4" Mopar Lift Kits Only



B. P5155416

C.

### C. Anti-Sway Bar Kit

Jeep Commander Anti-Sway Bar Kit includes both front and rear bars and bushing sets. Bars are made of a high-quality material that ensures durability and are powder-coated to protect them from the elements. Bars reduce body roll and help to keep the tires firmly planted on the ground. Dimensions: Front 35 mm, Rear 22 mm.

- <sup>1</sup> P5153727 Anti-Sway Bar, Stage 1, 2006-08 Jeep Commander, 5.7L

### D. Lowering Springs

Lowering kit includes all four springs, made of high-tensile material, to increase spring performance without bind. These springs provide a .75" front drop and a 1.5" drop in the rear, to lower and even out your ride.

- <sup>1</sup> P5153728 Lowering Springs, 2006-08, Jeep Commander, 5.7L



D.

E. P5153565

### E. Strut Tower Brace

Made of heavy gauge, powder coated steel, this MIG-welded Mopar Strut Tower Brace reduces body flex in the front end, improving handling and drivability. Easy bolt-on installation.

- <sup>1</sup> P5153565 Strut Tower Brace, Front, Steel, 2007-09 Compass/Patriot/Caliber, Non-Turbo

## JEEP/RAM

### SUSPENSION UPGRADES AND COMPONENTS

#### A. Additional Rear Leaf Spring

Add-a-leaf kits allow for the installation of larger tires and help compensate for heavy accessories. These kits will increase the ride height and spring rate for a fraction of the cost of replacement springs. Sold individually.

<sup>1</sup> P4349540 Leaf Spring, Additional, Rear, 4WD, W100/W150/W200/W300/Ramcharger/Trailduster

### IGNITION AND ELECTRONICS

#### B. Engine Controllers- Jeep

Direct replacement for the production computers. Provide increases in both horsepower and torque without affecting driveability.

<sup>1</sup> P5249518 Engine Controller, 1993-94 5.2L 4x4 Automatic Transmission Grand Cherokee

<sup>1</sup> P5249702 Engine Controller, 1995 5.2L 4x4 Automatic Transmission Grand Cherokee

Note: Emissions exempt in California, Massachusetts and New York only. Requires the use of premium unleaded fuels (92 octane or better). 1998 and later models require Vehicle Identification Number (VIN) and Mileage encoding by a Chrysler franchised dealer. Not recommended for towing applications.

**IMPORTANT NOTICE:** This device is not legal for use on pollution-controlled vehicles certified for use on streets or highways. Once this device is installed, use of the vehicle on a street or highway is a violation of the Clean Air Act, potentially subjecting the operator and the installer to civil penalties of up to \$32,500 per vehicle depending on the circumstances.



A.



B.

## IGNITION AND ELECTRONICS

### A. Engine Controllers- Truck

Direct replacement for the production computers. Provide increases in both horsepower and torque without affecting driveability.

- <sup>1</sup> P5249516 Engine Controller, 1992-93 5.2L Dakota
- <sup>1</sup> P5249545 Engine Controller, 1994-95 5.2L Ram/Dakota, Automatic Transmission
- <sup>1</sup> P5249546 Engine Controller, 1994-95 5.9L Ram, Automatic Transmission
- <sup>1</sup> P5249548 Engine Controller, 1994-95 8.0L Ram, Automatic Transmission
- <sup>1</sup> P5249955AB Engine Controller, 1996 5.2L Ram, Automatic Transmission
- <sup>1</sup> P5153734AC Engine Controller, 360 MPI Kit, Automatic Transmission
- <sup>1</sup> P5249935 Engine Controller, 5.9L Magnum, Automatic Transmission

NOTE: Emissions exempt in California, Massachusetts and New York only. Requires the use of premium unleaded fuels (92 octane or better). 1998 and later models require Vehicle Identification Number (VIN) and Mileage encoding by a Chrysler franchised dealer. Not recommended for towing applications.

IMPORTANT NOTICE: This device is not legal for use on pollution-controlled vehicles certified for use on streets or highways. Once this device is installed, use of the vehicle on a street or highway is a violation of the Clean Air Act, potentially subjecting the operator and the installer to civil penalties of up to \$32,500 per vehicle depending on the circumstances.

### B. Engine Controller- Ram SRT10

Plug in this performance-engineered Engine Controller and experience an immediate increase in horsepower and torque. Fuel and spark settings are adjusted for use with the required performance camshaft (P4510171) and exhaust headers (P4510844 or P5153168). Manual transmission only.

- <sup>1</sup> P4510918 Engine Controller, 2004 SRT10 Ram 1500
- <sup>1</sup> P5153335 Engine Controller, 2005 SRT10 Ram 1500

IMPORTANT NOTICE: This device is not legal for use on pollution-controlled vehicles certified for use on streets or highways. Once this device is installed, use of the vehicle on a street or highway is a violation of the Clean Air Act, potentially subjecting the operator and the installer to civil penalties of up to \$32,500 per vehicle depending on the circumstances.

## AUTOMATIC TRANSMISSION COMPONENTS

### C. Flywheel Hardware Kit

Contains all the bolts required to attach the flywheel and clutch to the engine assembly. Includes six flywheel bolts, six clutch bolts, pilot bearing and seal.

- P4529636AB** Hardware Kit, Flywheel, 4.0L AMC 360 Jeep Manual Transmission



A.



B.



C.

Questions? Call the Mopar Direct Connection Techline at 1-888-528-HEMI (4364)

<sup>1</sup> Not legal on pollution-controlled vehicles or vehicles registered for highway use.

JEEP/RAM

## TRANSMISSION/TRANSFER CASES

### Transfer Case (Not Shown)

- <sup>1</sup> P5155154 241 OR Transfer Case (Rubicon) Kit With Shift
- <sup>1</sup> P5155082 Yoke Kit, 1330 Double Cardan, w/ U-Joint
- <sup>1</sup> P5155079 Chain and Sprocket Kit, 231 HD

### Yokes (Not Shown)

- <sup>1</sup> P5155081 Yoke Kit, 1310 Double Cardan, w/ U-Joint
- <sup>1</sup> P5155080 Yoke Kit, 1330 Single Cardan, w/ U-Joint
- <sup>1</sup> P5155082 Yoke Kit, 1330 Double Cardan, w/ U-Joint

## DRIVETRAIN AND REAR AXLE COMPONENTS

### A. Axle Assemblies

These New Generation axle assemblies will provide the next level of off-road performance for your Jeep or Ram vehicle. All axles are shipped with the current suspension mounting brackets installed. Adaptation of these units into previous models is the responsibility of the purchaser. These axles come completely assembled and may include features such as disc brakes, and a Tru-Lok® electric, selectable locking differential.



A. P5155084



A. P5155256

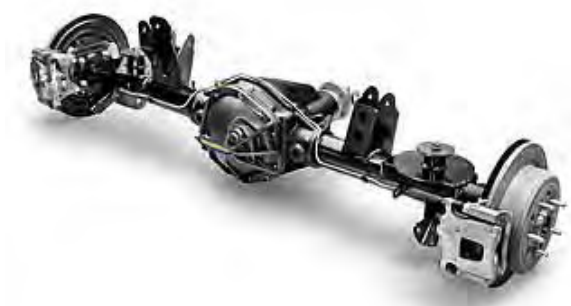

A. P5155257



A. P5153826AB

- <sup>1</sup> **P5153825AD** Axle, Front Assembly, Dana 44, 2007-10 Jeep Wrangler, 4.10 Ratio, Tru-Lok® electric, selectable locking differential, 5 on 5.0" JK Wheel Pattern, w/o Brakes
- <sup>1</sup> **P5155256** Axle, Front Assembly, Dana 44, JK Modified For 1997-2006 TJ, 4.10 Ratio, Tru-Lok® electric, selectable locking differential, 5 on 4.5" TJ Wheel Pattern, Includes JK Brakes
- <sup>1</sup> **P5155084** Axle, Front Assembly, Dana 44, Military J8 Wrangler, 4.10 Ratio, with Open Differential, 5 on 5.5" Hub, Includes J8 Military Brakes
- <sup>1</sup> **P5155087AB** Axle, Front Assembly, Stock Ram 2500 Power Wagon, 4.56 Ratio, With Electric Selectable Locker, 8 on 6.5" Wheel pattern, w/o Brakes
- <sup>1</sup> **P5155757** Axle, Partial Front Assembly, Dynatrac ProRock 44®, 2007-10 Jeep Wrangler. Includes 4.88 ratio, and Tru-Lok® electric, selectable, locking differential. Includes Differential Cover, OEM Ball Joints, HD 3" x 1/2" wall axle tubes and increased pinion angle and caster angle for lifted suspension. Ready To Accept Customer Supplied Wrangler JK knuckles, hubs, and brakes. Accepts Customer Supplied Wrangler Rubicon Dana 44 front axle shafts or P5155758 and P5155759 inner shafts.
- <sup>1</sup> **P5153826AB** Axle, Rear Assembly, 2007-10 Jeep Wrangler Rubicon, 4.10 Ratio, Tru-Lok® electric, selectable locking differential, 5 on 5.0" JK Wheel Pattern, w/ Brakes
- <sup>1</sup> **P5155257** Axle, Rear Assembly, Dana 44, JK Modified For 1997-2006 TJ, 4.10 Ratio, Tru-Lok® electric, selectable locking differential, 5 on 4.5" TJ Wheel Pattern, w/ Brakes
- <sup>1</sup> **P5155260** Axle, Rear Assembly, Dana 60, Military J8 Wrangler, 4.10 Ratio, Limited Slip Differential, 5 on 5.5" and 5 on 5.0" Wheel Pattern, Modified For JK, w/ J8 Military Brakes
- <sup>1</sup> **P5155083** Axle, Rear Assembly, Dana 60, Military J8 Wrangler, 4.10 Ratio, Limited Slip Differential, 5 on 5.5" Wheel Pattern, Leaf Spring, w/ J8 Brakes
- <sup>1</sup> **P5155088AB** Axle, Rear Assembly, Stock Ram 2500 Power Wagon, 4.56 Ratio, With Electric, Selectable Locker, 8 on 6.5" Wheel Pattern, w/o Brakes

Questions? Call the Mopar Direct Connection Techline at 1-888-528-HEMI (4364)

<sup>1</sup> Not legal on pollution-controlled vehicles or vehicles registered for highway use.



## JEEP/RAM

### DRIVETRAIN AND REAR AXLE COMPONENTS

#### Portal Axles (Not Shown)

Off road use only. These heavy duty axle assemblies increase vehicle lift to 5" and require 17" or greater size wheels. The bolt pattern is 8-lug and the track width will be increased by 8" on each side.

- <sup>1</sup> P5155670 Axle, Portal, Front, 8-Lug
- <sup>1</sup> P5155671 Axle, Portal, Rear, 8-Lug

#### A. Differential Covers- Heavy Duty

Mopar's extreme heavy duty Differential Covers offer upgraded protection for your axle's differential. Made from nodular castings, these covers provide increased strength and protect your differential from severe impacts such as rocks and off road obstacles. They also greatly enhance the rugged look of your axles. Each cover comes with exclusive "Jeep" badging.

- P5155445 Cover, Differential, Dana 30, "Jeep" Badging
- P5155446 Cover, Differential, Dana 44, "Jeep" Badging
- P5155447 Cover, Differential, Dana 60, "Jeep" Badging

#### B. Differential Cover Protectors

Rock rash insurance for your factory (O.E.) differential covers. Mopar's differential protectors are laser-cut from .250" steel then coated with a durable silver Zinc finish.

- P5155777 Guard, Differential, AMC 20, Laser Cut "Jeep"
- P5155442 Guard, Differential, Dana 30, Laser Cut "Jeep"
- P5155778 Guard, Differential, Dana 35, Laser Cut "Jeep"
- P5155443 Guard, Differential, Dana 44, Laser Cut "Jeep"
- P5155444 Guard, Differential, Dana 60 (J8), Laser Cut "Jeep"
- P5155780 Guard, Differential, Chrysler Axle, 8.25" Gear, w/o Electronic Limited Slip, Laser Cut "Jeep"
- P5155779 Guard, Differential, Chrysler Axle, 8.25" Gear, Electronic Limited Slip, Laser Cut "Jeep"
- P5155781 Guard, Differential, Chrysler Axle with 9.25" Gear, Laser Cut "Ram"
- P5155677 Guard, Differential, AAM Axle with 10.5" Gear, Laser Cut "RAM"
- P5155678 Guard, Differential, AAM Axle with 11.5" Gear, Laser Cut "RAM"

### AXLE COMPONENTS

#### C. Locker Wiring Harness

Jeep Rubicon Tru-Lok® locking differential activation wire harness. Facilitates installation of axles equipped with Tru-Lok® in most vehicles.

- P5155359 Harness, Wiring, Allows Locker Axles To Be Powered



A. P5155446



B. P5155678



B. P5155442



C. P5155359



**AXLE COMPONENTS**

**A. Dana 44 Components**

- P5155759 Axle Shaft, DANA 44F, Left, Inner, 4340 Chrome Moly, JK
- P5155760 Axle Shaft, DANA 44F, Outer, 4340 Chrome Moly, JK
- P5155758 Axle Shaft, DANA 44F, Right Inner, 4340 Chrome Moly, JK
- P5155756 Housing Only, Front, Dynatrac ProRock 44®, 2007-10 Jeep Wrangler. Includes Differential Cover, OEM Ball Joints, HD 3" x 1/2" wall axle tubes, increased pinion angle and caster angle for lifted suspension. Accepts customer supplied Wrangler JK knuckles, hubs, and brakes. Also accepts stock Rubicon Dana 44 ring & pinion with Tru-Lok® electric, selectable, locking differential. Re-uses stock Rubicon 44 front axle shafts or P5155758 and P5155759 inner axle shafts.

**B. Ram Locking Hub Conversion Kit**

Free Spin® Hub Conversion by Dynatrac, includes Warn lockout hubs. This kit reduces front axle wear and improves fuel efficiency by permitting the driver to disengage the front axle shafts and driveshaft rotation when operating in 2WD. For trucks with Single Rear Wheels (SRW).

- P5155762 Hub Conversion, Free Spin, 00-08 Ram 2500 4WD, SRW



A. P5155756

B. P5155762

**EXTERIOR BODY COMPONENTS**

**C. Hemi Hockey Stick Graphics Kits**

Kit includes Hemi® Hockey Stick Graphics (driver and passenger bed sides) and hood stripe. Fits both long and short bed trucks. Material is Avery two mil high-performance cast vinyl film, die-cut and pre-masked. Kit includes step-by-step installation instructions and application squeegee.

- P4510272 Graphics Kit, Hemi Hockey Stick, Black, 2007 Dodge Ram 6.5' and 8.0' Bed
- P4510274 Graphics Kit, Hemi Hockey Stick, Silver Metallic, 2007 Dodge Ram 6.5' and 8.0' Bed
- P4510273 Graphics Kit, Hemi Hockey Stick, White, 2007 Dodge Ram 6.5' and 8.0' Bed

**D. Hemi Billboard Graphics Kits**

Kit includes Hemi® Billboard Graphics (driver and passenger bed sides) and hood stripe. For short bed trucks only. Material is Avery two mil high-performance cast vinyl film, die-cut and pre-masked. Kit includes step-by-step installation instructions and application squeegee.

- P4510275 Graphics Kit, Hemi Billboard, Black, 2007 Dodge Ram, 6.5' Bed
- P4510277 Graphics Kit, Hemi Billboard, Silver Metallic, 2007 Dodge Ram 6.5' Bed

**E. Grille Assembly, Wire Mesh, Stainless**

- 77DUB01023 Grille, Chrome, Wire Mesh, 2006 Commander
- 77070001 Grille, Chrome, Wire Mesh, 2007-09 Wrangler, 2/4DR



C.

D.



E.

E.

Questions? Call the Mopar Direct Connection Techline at 1-888-528-HEMI (4364)

<sup>1</sup> Not legal on pollution-controlled vehicles or vehicles registered for highway use.

## JEEP/RAM

### EXTERIOR BODY COMPONENTS

#### A. Corner Guards

Help protect your wrangler's rear corners with these heavy duty Corner Guards. Stamped from 1/8" steel, these guards fit the contours of your Jeep. Available for 2-door or 4-door.

- P5155349 Corner Guards, Rear, 2007-09 Wrangler 2-Dr.
- P5155350 Corner Guards, Rear, 2007-09 Wrangler 4-Dr.

#### B. Bumpers

- P5155481 Bumper, Front, Integrated Winch Mount, 1982-01 Cherokee (XJ)
- P5155352 Bumper, Front, Integrated Winch Mount, 2007-10 Wrangler (JK)
- P5155353 Skid Plate, For Use With Bumper P5155352, 2007-10 Wrangler (JK)

#### Doors (Not Shown)

- <sup>1</sup> P5155495 Doors, Safari, 1984-01 Cherokee (XJ), 4-Dr.

#### Rock Rails (Not Shown)

- P5155494 Rock Rails, 1984-01 Cherokee (XJ), 4-Dr.

#### C. Pre-Runner Body Components

- <sup>1</sup> P5155663 Bumper, Front, 2009-10 Ram (DS) 1500, Pre-Runner
- <sup>1</sup> P5155665 Fenders, Front, 2009-10 Ram (DS) 1500, Pre-Runner
- <sup>1</sup> P5155666 Quarter Panels, 2009-10 Ram (DS) 1500, Pre-Runner
- <sup>1</sup> P5155664 Tire Carrier, 2009-10 Ram (DS) 1500, Pre-Runner

### HOODS AND HOOD COMPONENTS

#### D. Hoods

Add style and functionality with this stamped steel hood. Heavy gauge galvanized hood is delivered E-coated and ready to paint. Complete bolt-on package uses existing factory hardware.

- <sup>1</sup> P5155351 Hood, Heat Reduction, 2007-09 Wrangler

### OFF ROAD TOOLS AND ACCESSORIES

#### E. Jack Base

Provides needed extra lift to your factory scissor jack when changing taller tires. Stores neatly in your Wrangler's rear compartment.

- P5155336 Jack Base, 7.5" W x 10.5" L x 3.5" H



A.



A.



B. P5155481



B. P5155352



C.



C.



C.



D.



D.



E. (Jack Not Included)

## MOPAR®: 2 Fast 2 Furious

How do you measure performance? Miles per hour? Revolutions per minute? Heads turned per mile? However you compute it, Mopar® has a gauge for that and lighting to let the world know how well you measure up. Of course, when you're running Mopar, you're already way ahead of the pack.





# PERFORMANCE GAUGES 19

PERFORMANCE GAUGES



27-11-1996 11:25

# PERFORMANCE GAUGES

## GAUGES

Mopar Performance Gauges - Created using race proven Auto Meter components, Mopar Performance Gauges are now infused with superior LED through-the-dial O.E. quality lighting, to provide "at-a-glance" readings day or night.

### Full Sweep Electronic

Powered by digital, microprocessor-controlled, rugged stepper motor drives and laboratory-grade sending units, Full Sweep Electronic Gauges are the BEST gauges available. Extreme durability and readability of 270-degree sweep mechanical gauges is combined with easy installation and safe operation of short sweep electronics. Track-tested and race-proven, these units employ precision senders to keep hazardous fluids out of the driver compartment and to perform gauge calibration and sensor diagnostics at power-up for extreme accuracy every time. Most units are compatible with Auto Meter Data Logger, for the ultimate race info center.

### Short Sweep Electronic

Advanced 90-degree air core movements and simple three-wire installation characterize these high-performance instruments. Electrical signals collect data generated from hazardous fluids in the engine compartment to ensure precision. It's all the information you need-and nothing you don't.

### Mechanical

Bronze Bourdon tube, 270-degree sweep movements, and durable nylon gearing have made these rugged and long lasting gauges a proven high-performance favorite for more than 25 years. These mechanical gauges require no electrical power for operation, which makes them an ideal choice for vehicles with no- or low-powered electrical systems.

## A. Boost Vacuum

- 77060061 Boost Vacuum, Diesel, Full Sweep, Electronic, 2 1/16", Range: 0-30 psi, Black Dial
- 77060060 Boost Vacuum, Diesel, Full Sweep, Electronic, 2 1/16", Range: 0-30 psi, White Dial
- 77060030 Boost Vacuum, Diesel, Full Sweep, Mechanical, 2 1/16", Range 0-35 psi, White Dial
- 77060031 Boost Vacuum, Diesel, Full Sweep, Mechanical, 2 1/16", Range: 0-35 psi, Black Dial
- 77060033 Boost Vacuum, Full Sweep, Mechanical, 2 1/16", 20 psi/30" hg, Black Dial
- 77060032 Boost Vacuum, Full Sweep, Mechanical, 2 1/16", 20 psi/30" hg, White Dial



A. 77060060 (Day)



A. 77060060 (Night)



A. 77060033 (Day)



A. 77060033 (Night)



A. 77060032 (Day)



A. 77060032 (Night)



A. 77060031 (Day)



A. 77060031 (Night)



A. 77060030 (Day)



A. 77060030 (Night)



A. 77060061 (Day)



A. 77060061 (Night)

GAUGES

A. Fuel Level

- 77060043 Fuel Level, Full Sweep, Electronic, 2 1/16", Black Dial
- 77060042 Fuel Level, Full Sweep, Electronic, 2 1/16", White Dial

B. Oil Pressure

- P5155501 Oil Pressure, Full Sweep, Electronic, 2 5/8", Range: 0-100 psi, White Dial
- 77060035 Oil Pressure, Full Sweep, Mechanical, 2 1/16", Range: 0-100 psi, Black Dial
- 77060034 Oil Pressure, Full Sweep, Mechanical, 2 1/16", Range: 0-100 psi, White Dial
- 77060045 Oil Pressure, Short Sweep, Electronic, 2 1/16", Range: 0-100 psi, Black Dial
- 77060044 Oil Pressure, Short Sweep, Electronic, 2 1/16", Range: 0-100 psi, White Dial

Oil Temperature (Not Shown)

- P5155503 Oil Temperature, Full Sweep, Electronic, 2 5/8", Range: 140-280° F, White Dial



A. 77060042 (Day)



A. 77060042 (Night)



A. 77060043 (Day)



A. 77060043 (Night)



B. 77060034 (Day)



B. 77060034 (Night)



B. 77060035 (Day)



B. 77060035 (Night)



B. 77060044 (Day)



B. 77060044 (Night)



B. 77060045 (Day)



B. 77060045 (Night)

Questions? Call the Mopar Direct Connection Techline at 1-888-528-HEMI (4364)

<sup>1</sup> Not legal on pollution-controlled vehicles or vehicles registered for highway use.

# PERFORMANCE GAUGES

## GAUGES

### A. Pyrometer

77060047 Pyrometer, Full Sweep, Electronic, 2 1/16", Range: 0-1,600° F, Black Dial

77060046 Pyrometer, Full Sweep, Electronic, 2 1/16", Range: 0-1,600° F, White Dial

### B. Speedometer

77060055 Speedometer, In-Dash, Full Sweep, Electronic, 3 3/8", Range: 0-160 mph, Black Dial

77060054 Speedometer, In-Dash, Full Sweep, Electronic, 3 3/8", Range: 0-160 mph, White Dial



A. 77060046 (Day)



A. 77060046 (Night)



A. 77060047 (Day)



A. 77060047 (Night)



B. 77060054 (Day)



B. 77060054 (Night)



B. 77060055 (Day)



B. 77060055 (Night)



GAUGES

A. Tachometers

- 77060057 Tachometer, In-Dash Mount, Full Sweep, Electronic, 3 3/8", Range: 0-10,000 rpm, Black Dial
- 77060056 Tachometer, In-Dash Mount, Full Sweep, Electronic, 3 3/8", Range: 0-10,000 rpm, White Dial
- 77060059 Tachometer, Pedestal-Mount with Shift Light, Full Sweep, Electronic, 3 3/8", Range: 0-10,000 rpm, Black Dial
- 77060058 Tachometer, Pedestal-Mount with Shift Light, Full Sweep, Electronic, 3 3/8", Range: 0-10,000 rpm, White Dial
- P5155500 Tachometer, Pedestal-Mount, w/ Shift Light, Full Sweep, Electronic, 5", Range: 0-10,000 rpm, White Dial

B. Shift Light

- P5155508 Shift Light, Digital



A. 77060056 (Day)



A. 77060056 (Night)



A. 77060057 (Day)



A. 77060057 (Night)



A. 77060058 (Day)



A. 77060058 (Night)



A. 77060059 (Day)



A. 77060059 (Night)



B. P5155508



B. P5155508

Questions? Call the Mopar Direct Connection Techline at 1-888-528-HEMI (4364)

<sup>1</sup> Not legal on pollution-controlled vehicles or vehicles registered for highway use.

## PERFORMANCE GAUGES

### GAUGES

#### A. Transmission Temperature

- P5155885 Transmission Temperature, Full Sweep, Electronic, 2 5/8", Range: 100 - 260° F, White Dial
- 77060048 Transmission Temperature, Short Sweep, Electronic, 2 1/16", Range: 100 - 260° F, White Dial
- 77060049 Transmission Temperature, Short Sweep, Electronic, 2 1/16", Range: 100 - 260° F, Black Dial

#### B. Voltmeters

- 77060051 Voltmeter, Short Sweep, Electronic, 2 1/16", Range: 8-18 Volts, Black Dial
- 77060050 Voltmeter, Short Sweep, Electronic, 2 1/16", Range: 8-18 Volts, White Dial
- P5155504 Voltmeter, Short Sweep, Electronic, 2 5/8", Range: 8-18 Volts, White Dial



A. 77060048 (Day)



A. 77060048 (Night)



A. 77060049 (Day)



A. 77060049 (Night)



B. 77060050 (Day)



B. 77060050 (Night)



B. 77060051 (Day)



B. 77060051 (Night)

GAUGES

A. Water Temperature

- 77060053 Water Temperature, Full Sweep, Electronic, 2 1/16", Range: 100-260° F, Black Dial
- 77060052 Water Temperature, Full Sweep, Electronic, 2 1/16", Range: 100-260° F, White Dial
- P5155502 Water Temperature, Full Sweep, Electronic, 2 5/8", Range: 100-260° F, White Dial
- 77060039 Water Temperature, Short Sweep, Electronic, 2 1/16", Range: 100-250° F, Black Dial
- 77060038 Water Temperature, Short Sweep, Electronic, 2 1/16", Range: 100-250° F, White Dial



A. 77060052 (Day)



A. 77060052 (Night)



A. 77060053 (Day)



A. 77060053 (Night)



A. 77060038 (Day)



A. 77060038 (Night)



A. 77060039 (Day)



A. 77060039 (Night)

Questions? Call the Mopar Direct Connection Techline at 1-888-528-HEMI (4364)  
 † Not legal on pollution-controlled vehicles or vehicles registered for highway use.

# PERFORMANCE GAUGES

## GAUGES

### A. Jeep Gauges

These gauges are durable, waterproof, and accurate. Just what you need for your Jeep! We have the hard to find transfer case and axle temperature gauges, along with a full compliment of standard gauges. Each gauge comes with the Jeep logo, and all the necessary sending units and mounting hardware.

- P5155706** Speedometer, Full Sweep, Electronic, 3 3/8", Range: 0-120 mph, Jeep Dial
- P5155707** Tachometer, Full Sweep, Electronic, 3 3/8", Range: 0-8,000 rpm, Jeep Dial
- P5155708** Voltmeter, Short Sweep, Electronic, 2 1/16", Range: 10-16 Volts, Jeep Dial
- P5155710** Water Temperature, Short Sweep, Electronic, 2 1/16", Range: 100-250° F, Jeep Dial
- P5155711** Transmission Temperature, Short Sweep, Electronic, 2 1/16", Range: 120-280° F, Jeep Dial
- P5155714** Transfer Case Temperature, Short Sweep, Electronic, 2 1/16", Range: 140-320° F, Jeep Dial
- P5155715** Axle Temperature, Short Sweep, Electronic, 2 1/16", Range: 140-320° F, Jeep Dial
- P5155713** Oil Temperature, Short Sweep, Electronic, 2 1/16", Range: 140-320° F, Jeep Dial
- P5155712** Oil Pressure, Short Sweep, Electronic, 2 1/16", Range: 0-100 PSI, Jeep Dial
- P5155765** Fuel Level, Short Sweep, Electronic, 220 OHMS Empty/ 200 OHMS Full, 2 1/16", T.J, Jeep Dial
- P5155709** Fuel Level, Short Sweep, Electronic, 2 1/16", YJ, Jeep Dial
- P5155764** Fuel Level, Short Sweep, Electronic, 73 OHMS Empty/ 10 OHMS Full, 2 1/16", CJ/SJ, Jeep Dial

See chart for additional information.



A. P5155706



A. P5155707



A. P5155708



A. P5155709



A. P5155710



A. P5155711



A. P5155712



A. P5155713



A. P5155714



A. P5155715

## GAUGES

## PERFORMANCE GAUGES

Part Number	Description	Gage Spec.	Size	Type	Face Color (Day)	Face Color (Night)	Logo	Logo Color
P5155715	Axle Temperature	140-320 F	2-1/16"	SSE	Black	Black	Jeep	Green
77060032	Boost Vacuum	30 IN. HG /20 PSI	2-1/16"	MECH	White	Black	Mopar	Blue
77060033	Boost Vacuum	30 IN. HG /20 PSI	2-1/16"	MECH	Black	Black	Mopar	Blue
77060060	Boost Vacuum (Diesel)	0-30 PSI	2-1/16"	FSE	White	Black	Mopar	Blue
77060061	Boost Vacuum (Diesel)	0-30 PSI	2-1/16"	FSE	Black	Black	Mopar	Blue
77060031	Boost Vacuum (Diesel)	0-35 PSI	2-1/16"	MECH	Black	Black	Mopar	Blue
77060030	Boost Vacuum (Diesel)	0-35 PSI	2-1/16"	MECH	White	Black	Mopar	Blue
77060043	Fuel Level		2-1/16"	FSE	Black	Black	Mopar	Blue
77060042	Fuel Level		2-1/16"	FSE	White	Black	Mopar	Blue
P5155764	Fuel Level (Jeep CJ/SJ)		2-1/16"	SSE	Black	Black	Jeep	Green
P5155765	Fuel Level (Jeep TJ)		2-1/16"	SSE	Black	Black	Jeep	Green
P5155709	Fuel Level (Jeep YJ)		2-1/16"	SSE	Black	Black	Jeep	Green
77060035	Oil Pressure	0-100 PSI	2-1/16"	MECH	Black	Black	Mopar	Blue
77060034	Oil Pressure	0-100 PSI	2-1/16"	MECH	White	Black	Mopar	Blue
P5155712	Oil Pressure	0-100 PSI	2-1/16"	SSE	Black	Black	Jeep	Green
77060045	Oil Pressure	0-100 PSI	2-1/16"	SSE	Black	Black	Mopar	Blue
77060044	Oil Pressure	0-100 PSI	2-1/16"	SSE	White	Black	Mopar	Blue
P5155501	Oil Pressure	0-100 PSI	2-5/8"	FSE	White	Black	Mopar	Blue
P5155713	Oil Temperature	140-320 F	2-1/16"	SSE	Black	Black	Jeep	Green
P5155503	Oil Temperature	140-280 F	2-5/8"	FSE	White	Black	Mopar	Blue
77060046	Pyrometer	0-1,600 F	2-1/16"	FSE	White	Black	Mopar	Blue
77060047	Pyrometer	0-1,600 F	2-1/16"	FSE	Black	Black	Mopar	Blue
P5155706	Speedometer	0-120 MPH	3-3/8"	FSE	Black	Black	Jeep	Green
77060054	Speedometer	0-160 MPH	3-3/8"	FSE	White	Black	Mopar	Blue
77060055	Speedometer	0-160 MPH	3-3/8"	FSE	Black	Black	Mopar	Blue
77060056	Tachometer	0-10,000 RPM	3-3/8"	FSE	White	Black	Mopar	Blue
77060057	Tachometer	0-10,000 RPM	3-3/8"	FSE	Black	Black	Mopar	Blue
P5155707	Tachometer	0-8,000 RPM	3-3/8"	FSE	Black	Black	Jeep	Green
77060058	Tachometer (Pedestal Mount), w Shift Light	0-10,000 RPM	3-3/8"	FSE	White	Black	Mopar	Blue
77060059	Tachometer (Pedestal Mount), w Shift Light	0-10,000 RPM	3-3/8"	FSE	Black	Black	Mopar	Blue
P5155500	Tachometer (Pedestal Mount), w Shift Light	0-10,000 RPM	5"	FSE	White	Black	Mopar	Blue
P5155508	Tachometer Shift Light, Digital				Silver		Mopar	Blue
P5155714	Transfer Case Temperature	140-320 F	2-1/16"	SSE	Black	Black	Jeep	Green
P5155711	Transmission Temperature	120-280 F	2-1/16"	SSE	Black	Black	Jeep	Green
77060049	Transmission Temperature	100-260 F	2-1/16"	SSE	Black	Black	Mopar	Blue
77060048	Transmission Temperature	100-260 F	2-1/16"	SSE	White	Black	Mopar	Blue
P5155885	Transmission Temperature	100-260 F	2-5/8"	FSE	White	Black	Mopar	Blue
77060051	Voltmeter	8-18 Volts	2-1/16"	SSE	Black	Black	Mopar	Blue
P5155708	Voltmeter	10-16 Volts	2-1/16"	SSE	Black	Black	Jeep	Green
77060050	Voltmeter	8-18 Volts	2-1/16"	SSE	White	Black	Mopar	Blue
P5155504	Voltmeter	8-18 Volts	2-5/8"	SSE	White	Black	Mopar	Blue
77060053	Water Temperature	100-250 F	2-1/16"	FSE	Black	Black	Mopar	Blue
77060052	Water Temperature	100-250 F	2-1/16"	FSE	White	Black	Mopar	Blue
P5155710	Water Temperature	100-250 F	2-1/16"	SSE	Black	Black	Jeep	Green
77060039	Water Temperature	100-250 F	2-1/16"	SSE	Black	Black	Mopar	Blue
77060038	Water Temperature	100-250 F	2-1/16"	SSE	White	Black	Mopar	Blue
P5155502	Water Temperature	100-260 F	2-5/8"	SSE	White	Black	Mopar	Blue

Questions? Call the Mopar Direct Connection Techline at 1-888-528-HEMI (4364)

<sup>1</sup> Not legal on pollution-controlled vehicles or vehicles registered for highway use.

## PERFORMANCE GAUGES

### GAUGE PODS

These Gauge Pods from Mopar Performance are available for the popular 2 1/16" gauges. Premium-grade automotive ABS is formed and trimmed to perfectly fit each application, giving a clean, factory look. Easy installation, with little or no modifications to the vehicle's interior. Not recommended for vehicles equipped with an A-pillar mounted air bag.

#### A. Gauge Pods - Single

**P4510560** Gauge Pod, Single, A-Pillar Mount, Black Finish, 2003-05 Neon SRT4, 2000-05 Neon



#### B. Gauge Pods - Dual

**77060072** Gauge Pod Kit , Dual, A-Pillar Mount, Tan, Contains Pod 77060067, Boost Vacuum Gauge 77060030, and Pyrometer Gauge 77060046, 2003-08 Dodge Ram

**P4510567** Gauge Pod, Dual, A-Pillar Mount, Beige, 2001-05 PT Cruiser

**77060063** Gauge Pod, Dual, A-Pillar Mount, Black, 2000-05 Neon

**P4510559** Gauge Pod, Dual, A-Pillar Mount, Black, 2003-05 Neon SRT4, 2000-05 Neon

**77060062** Gauge Pod, Dual, A-Pillar Mount, Black, 2004-08 Magnum/300/Charger

**77060067** Gauge Pod, Dual, A-Pillar Mount, Tan, 2003-08 Ram

**77060066** Gauge Pod, Dual, Dash Mount, Black, 1997-05 Wrangler

**77060069** Gauge Pod, Dual, Overhead Mount, Black, 2003-08 Ram



#### C. Gauge Pods - Triple

**77060073** Gauge Pod Kit , Triple, A-Pillar Mount, Tan, Contains Pod 77060068, Boost Vacuum Gauge 77060030, Pyrometer Gauge 77060046, and Transmission Temperature Gauge 77060048, 2003-08 Dodge Ram

**77060064** Gauge Pod, Triple, A-Pillar Mount, Black, 2000-05 Neon

**77060068** Gauge Pod, Triple, A-Pillar Mount, Tan, 2003-08 Ram

**77060065** Gauge Pod, Triple, Dash Mount, Black, 2003-08 Ram

**77060070** Gauge Pod, Triple, Overhead Mount, Black, 2003-05 Ram



#### D. Gauge Pods - Quad

**77060071** Gauge Pod, Quad, Overhead Mount, Black, 2003 - 05 Ram



## GAUGE COMPONENTS

#### E. Tachometer Signal Adapter

**P4510598** Tachometer Adapter, Required for all applications without a distributor

#### F. Speedometer Components

**04897646AA** Speedometer Cable, 1968-75 A/B/E-Bodies (without cruise control)



A.

B.

C. 77060073

D. 77060071

E.

F. 04897646AA

GAUGE COMPONENTS

A. Tach Adapter

Designed for applications when high-capacitive discharge coils interfere with tachometer or fuel injection signals. Provides a clear 12-volt square wave signal output with a 30% duty cycle.

P4876738 Tachometer Adapter, V8



A.

---







PROFORMANCE

Plymouth

27-11-1005 10:29

# SILVERSTAR LIGHTING

## LAMPS

### A. SilverStar HID Lamps

Maximum color temperature up to 5000 Kelvin. Blue-white effect with homogeneous light distribution.

- P0000HIDD1 Headlamp, HID D1
- P0000HIDD2 Headlamp, HID D2

### B. SilverStar Ultra Halogen Lamps

The Silverstar Ultra series produce 20% more light than standard SilverStar Headlights. This gives you 25% increased downroad viewing, and an increased sideroad view.

- P0009004SU Headlamp, Silverstar Ultra, 9004
- P0009005SU Headlamp, Silverstar Ultra, 9005
- P0009006SU Headlamp, Silverstar Ultra, 9006
- P0009007SU Headlamp, Silverstar Ultra, 9007

### C. SilverStar Halogen Lamps

SilverStar Headlights produce a whiter light, closer to the color of daylight. Whiter light helps you see better at night. And if your night vision is better, night driving is safer.

- PL009004ST Headlamp, Silverstar, 9004
- P0009005ST Headlamp, Silverstar, 9005
- P09005XSST Headlamp, SilverStar, 9005XS
- PL009006ST Headlamp, Silverstar, 9006
- PL9006XSST Headlamp, Silverstar, 9006XS
- PL009007ST Headlamp, Silverstar, 9007
- P00000H7ST Headlamp, SilverStar, H7
- P0000H13ST Headlamp, SilverStar, H13
- P0046024ST Headlight, Sealed Beam, Round, Silverstar, H6024
- P00H6054ST Headlight, Sealed Beam, Rectangular, Silverstar, H6054

### D. EcoBright Halogen Lamps

The Environmental Choice in Automotive Lighting:

- Save Energy - from 9 to 21% wattage savings
- Save Money - from \$2 to \$19 in gas over the life of a pair
- See Better - Drive Safer - 25% brighter than an aged standard bulb
- Environmentally Responsible:
  - Carbon Dioxide emissions are reduced from 13-107 lbs. over the life of a pair
  - EcoBright™ bulbs are mercury free, cadmium free, and lead free
  - Produced in factories committed to reducing the impact to the environment

- P0009004EB Headlamp, ECObright, 9004
- P0009005EB Headlamp, ECObright, 9005
- P0009006EB Headlamp, ECObright, 9006
- P0009007EB Headlamp, ECObright, 9007
- P00000H7EB Headlamp, ECObright, H7



A. P0000HIDD1



A. P0000HIDD2



B. P0009006SU



C. P0009005ST



C. P0046024ST



D. P0009004EB

LAMPS

A. Silverstar Back-Up/Signal Lamps

SilverStar back-up/signal lighting is ideal for reverse lighting applications, especially on vehicles with back up cameras. They are suitable for, and add brilliance to, any signal lamp application.

- P001156STS Back-up/Signal Lamps, 1156
- P003157STS Back-up/Signal Lamps, 3157
- P007506STS Back-up/Signal Lamps, 7506
- P000921STS Back-up/Signal Lamps, 921

B. SilverStar Fog Lamps

- P0000880ST Fog Lamp, SilverStar, 880
- P0000893ST Fog Lamp, SilverStar, 893
- P0009145ST Fog Lamp, SilverStar, 9145



A. P003157STS



B. P0000893ST

Questions? Call the Mopar Direct Connection Techline at 1-888-528-HEMI (4364)  
¹ Not legal on pollution-controlled vehicles or vehicles registered for highway use.





P  
R  
I  
O  
R  
I  
T  
Y  
M  
E  
R  
C  
H  
A  
N  
D  
I  
S  
E

27-11-1995 11:29

## MERCHANDISE

### DIECAST

#### A. Display Engines

P5153582AB Display Engine, 426 Street Hemi, 1:6 Scale

P5153873AB Display Engine, 426 Hemi Top Fuel, Assembled, 1:6 Scale

#### B. Dodge

P5153797AC Diecast, 2008 Sox & Martin Pro Stock, 1:24 Scale

P5153922AB Diecast, 1964 Dodge 330 Sedan, 426 Hemi, Light Beige, 1:18 Scale

#### C. Dodge Charger

P5155792 Diecast, 1969 Dodge Charger R/T, Black, 1:18 Scale

P5155782 Diecast, 1970 Dodge Charger R/T SE, Go Mango (EK2 Orange), 1:18 Scale

P5155362 Diecast, 1970 Dodge Charger, 440-6, Panther Pink, 1:18 Scale

#### D. Dodge Challenger

P5155745 Diecast, 1970 Dodge Challenger Pro Stock, Bill Bagshaw's "RED LIGHT BANDIT", 1:18 Scale

P5153926AB Diecast, 1971 Dodge Challenger, Black, 1:18 Scale

#### E. Dodge Coronet

P5155360 Diecast, 1971 Dodge Coronet Super Bee, Butterscotch, 1:18 Scale

P5153777AB Diecast, 1967 Dodge Coronet, Dick Landy, 1:18 Scale

P5153874AB Diecast, 1967 Dodge Coronet R/T, 426 Hemi, Light Yellow, 1:18 Scale

P5153925AB Diecast, 1967 Dodge Coronet R/T, 426 Hemi, Mauve, 1:18 Scale



A. P5153582AB



A. P5153873AB



B. P5153797AC



B. P5153922AB



C. P5155362



C. P5155782



C. P5155792



D. P5155745



E. P5153925AB



E. P5153874AB



E. P5153777AB



E. P5155360



A. P5153498AB



A. P5155147



A. P5155148



B. P5155216



C. P5155136



C. P5155183



C. P5155214



C. P5155215



D. P5153951AB



D. P5155192



D. P5155364



D. P5155365

**DIECAST**

**A. Dodge Dart**

- P5153498AB Diecast, 1968 Super Stock Dodge Dart - Ron Mancini "Detroit Bee Leaver," 1:18 Scale
- P5155147 Diecast, 1970 Dodge Dart Swinger, 340, Go Mango, 1:18 Scale
- P5155148 Diecast, 1970 Dodge Dart Swinger, 340, Plum Crazy, 1:18 Scale

**B. Plymouth 'Cuda/Barracuda**

- P5155216 Diecast, 1971 Plymouth 'Cuda, Lime Green, 1:18 Scale

**C. Plymouth GTX**

- P5155214 Diecast, 1970 Plymouth GTX, Red, 1:18 Scale
- P5155215 Diecast, 1971 Plymouth GTX, Dark Green, 1:18 Scale
- P5155136 Diecast, 1967 Plymouth GTX, Black, 1:18 Scale
- P5155183 Diecast, 1970 Plymouth GTX, Hemi Orange, 1:18 Scale

**D. Plymouth Road Runner**

- P5155365 Diecast, 1969 Road Runner, 426 Hemi, Medium Bronze, 1:18 Scale
- P5155364 Diecast, 1969-1/2 Road Runner, 440-6, Blue Fire Metallic, 1:18 Scale
- P5153951AB Diecast, 1968 Plymouth Road Runner, No. 43 Richard Petty, 426 Hemi, Petty Blue w/ Black Vinyl Top, 1:18 Scale
- P5155192 Diecast, 1970 Plymouth Hemi Road Runner Convertible, B-5 Blue With White Top, 1:18 Scale

Questions? Call the Mopar Direct Connection Techline at 1-888-528-HEMI (4364)  
 † Not legal on pollution-controlled vehicles or vehicles registered for highway use.

## MERCHANDISE

### DIECAST

#### A. Team Mopar

- P5155746 Diecast, 2008 Mopar 392 Hemi Super Stock Drag Pak Concept (Red/White/Blue), 1:18 Scale
- P5155652 Diecast, 2009 Dodge Stratus Pro Stock, Allen Johnson, 1:24 Scale
- P5153317AB Diecast, 2004 NASCAR Dodge Intrepid, No. 9 Kasey Kahne, 1:24 Scale
- P4510853AB Diecast, 2004 NHRA Dodge Stratus Funny Car, Gary Scelzi, 1:16 Scale
- P5153531AB Diecast, 2005 World of Outlaws Sprint Car, No. 20 Danny Lasoski, 1:24 Scale
- P5153736AC Diecast, 2006 NHRA Dodge Stratus Pro Stock, Direct Connection, 1:24 Scale
- P5153797AB Diecast, 2006 NHRA Dodge Stratus Pro Stock, Sox & Martin, 1:24 Scale
- P5155153 Diecast, 2007 Kasey Kahne, NASCAR #9, With Mopar Paint Scheme, 1:24 Scale
- P5153729AC Diecast, Direct Connection Truck and Trailer, 1:64 Scale

#### B. Wing Cars

- P5155029AB Diecast, 1970 Plymouth Superbird, Mr. 5 & 50, Jack Werst, 1:18 Scale

### POSTERS

#### C. Mopar "Fire" Poster

- P5153656 Poster, Mopar "Fire", 36" x 24"

#### D. Mopar "Hell Yeah!" Poster

- P5153658 Poster, Mopar "Hell Yeah!", 36" x 24"



A. P5153317AB



A. P4510853AB



A. P5153531AB



A. P5153736AC



A. P5155025AB



A. P5155153



A. P5153729AC



A. P5155746



A. P5155652



B. P5155029AB



C. P5153656



D. P5153658





A. P5153657



B. P5249651AB

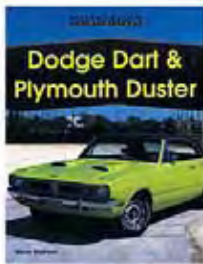

B. P5007691

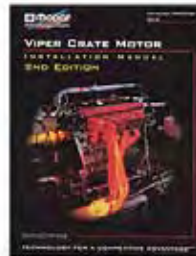

B. P5007220AC



B. P5249652AB

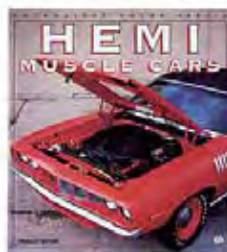

B. P5007516AC

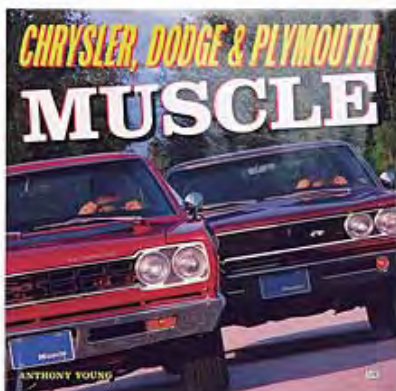

B. P5007517AC

POSTERS

A. Mopar "OPA!" Poster

P5153657 Poster, Mopar "OPA!", 36" x 24"

BOOKS

B. New! Chrysler, Dodge, and Plymouth

P5249649 Chrysler Muscle Cars (Enthusiast Color)- A full color gallery of Chrysler's fastest muscle cars- from high-revving small blocks to fire-breathing Hemis. Copyright 1993 Motorbooks International (96 pages)

P5249651AB CHRYSLER 300- The complete history of the Chrysler 300. From C-300 to 300L, this story covers "America's Most Powerful Car" from 1955-1961. Copyright Veloce Publishing (156 pages)

P5007691AC Dodge Dart & Plymouth Duster- Although they started their lives as rather innocuous economy cars, the Dodge Dart and Valiant-based Plymouth Duster grew into their own as true high-performance muscle cars. The transformation took place in 1967, when Mopar shoehorned in a Big Block 383-cubic-inch V8. There was no logical reason for this much power in an economy car other than the fact that horsepower fever had officially taken over Detroit. That's reason enough. This book chronicles the life and times of these classic Mopar muscle cars. Copyright 2000 Motorbooks International (128 pages)

P5007220AC Viper Crate Motor Installation Manual (2nd Edition)- A must-read for anyone who wants to install a Viper V10 aluminum crate motor into a hot rod or street rod chassis. Includes detailed package drawings showing engine and transmission mounting points, overall dimensions, critical clearances, etc., as well as important information on the following systems: fuel delivery, fuel injection, electrical, intake, exhaust, cooling and oiling.

P5249652AB Plymouth 1946-1959 - Everything muscle car fans need to know about these vehicles. (160 pages)

P5007516AC Hemi® Muscle Cars - A colorful history of Dodge and Plymouth Hemi production cars. Printed in full color. Copyright 1999 by Motorbooks International (96 pages)

P5007517AC Chrysler, Dodge & Plymouth Muscle- The exciting history of Dodge, Plymouth and Chrysler muscle cars in color. Copyright 1999 by Motorbooks International (192 pages)

## MERCHANDISE

### BOOKS

#### A. Dodge Trucks

**P5249655AB** DODGE Pickups- History and Restoration Guide 1918-1971. One of the most complete and detailed books covering the history of Dodge trucks. This publication is filled with photos from past- including Pickups, Panels, Stakes, Canopies, Screens, Suburbans, Power-Wagons, Route-Vans, Sweptsides, Town Panels, Town Wagons, Custom Sports Specials, Vans, Compact Pickups, Campers, and Adventurers. MBI Publishing (224 pages)

**P5007690AC** Dodge Pickup Trucks- Part of the Enthusiast Color Series from Motorboks International, this book covers many of the Ram trucks build from early Power Wagons of the 40's through the Dakotas and Durangos of the late 1990's (96 pages)

**P5007518AB** Dodge Pickup Color History -A full-color history of the Dodge Pickup. Covers 1916 to 1966 models. Copyright Motorbooks International (128 pages)

**P5007522AB** Mopar Street Truck- Do you own a V10, V8 or V6 Magnum-powered Dodge Ram, Dakota or Durango? If so, you'll want to get this book from Mopar Performance. Packed full of Dodge-truck-only performance strategies and package recommendations, it is highlighted with hundreds of photos and illustrations. Discussions on automatic transmissions and torque converters, manual transmissions and clutches, driveshafts and rear axles, ignition systems, front and rear suspension, body and chassis, brakes, shocks, wheels and tires are all included. Straight from Mopar Performance engineers, racers, and race teams, this book also contains bracket racing speed secrets and performance tips for those who want to take their trucks to the next level. A must for any Magnum-powered Dodge truck owner. (400 pages)

#### FENDER COVERS

##### B. Fender Covers

**P5153623** Fender Cover, Direct Connection, White on Black  
**P5153621** Fender Cover, Hemi, Orange on Black  
**P5153624** Fender Cover, Mopar, White on Black  
**P5153622** Fender Cover, Wedge, White on Black

#### WHEEL COVERS

##### C. Wheel Covers

**P5153626** Tire Cover, Hemi, Orange on White  
**P5153625** Tire Cover, Mopar, Blue on White  
**P5153627** Tire Cover, Vintage Direct Connection, Red/Blue/Black on White

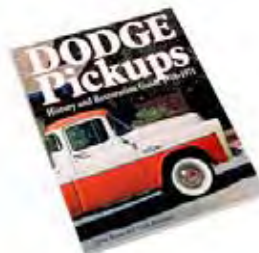

A. P5249655AB



A. P5007518AB

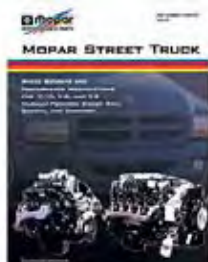

A. P5007522AB

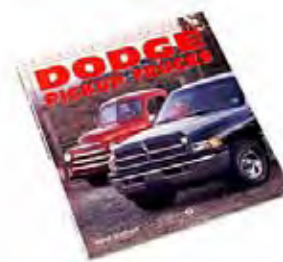

A. P5007690AC



B. P5153621



B. P5153622



B. P5153623



B. P5153624



C. P5153626



C. P5153625



C. P5153627



A. P5155724

A. P5155725- Shown on black for detail



B. P5155732- Shown on black for detail

B. P5155726- Shown on black for detail



C.



D.

DECALS

A. HEMI Decals

- P5155724 Decal, "HEMI", Orange, 1" x 8" Die Cut
- P5155725 Decal, "HEMI", White, 1" x 8", Die Cut

B. Mopar Decals

- P5155731 Decal, "MOPAR", Black on White, 0.75" x 4", Die Cut
- P5155732 Decal, "MOPAR", Black on White, 1" x 7", Die Cut
- P5155733 Decal, "MOPAR", Black on White, 1.25" x 10", Die Cut
- P5155726 Decal, "MOPAR", White, 1" x 8", Die Cut

C. Mopar Omega M Decals

- P5155730 Decal, Blue Mopar Omega M on White, 2.75" x 7.8", Die Cut
- P5155729 Decal, Blue Mopar Omega M on White, 5" x 5.25", Die Cut
- P5155728 Decal, Blue Mopar Omega M on White, 7.10" x 7.4", Die Cut
- P5155727 Decal, Blue Mopar Omega M on White, 10" x 10.5", Die Cut

D. Direct Connection Decals

- P5155793 Decal, "Direct Connection", Red, White & Blue, 5"



# VEHICLE IDENTIFICATION



# VEHICLE IDENTIFICATION

## DODGE AND PLYMOUTH VIN IDENTIFICATION

### 1964-65 Models

1964-65 models have the Vehicle Identification Number located on a stainless steel plate riveted to the left front door hinge pillar post.

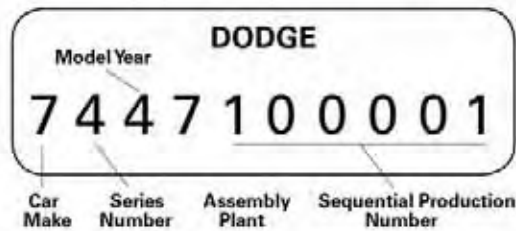

#### 1st Digit: Car Make

- 1 = Valiant Slant-6, Barracuda Slant-6
- 2 = Plymouth Slant-6 (1964) / Dart Slant-6 (1965)
- 3 = Plymouth V8 (1964) / Belvedere Slant-6 (1965)
- 4 = Dodge Slant-6 (1964) / Coronet Slant-6 (1965)
- 6 = Dodge V8 (1964)
- 7 = Dart slant-6 (1964)
- D = Dodge (1965)
- L = Dart V8
- R = Belvedere V8 (1965)
- V = Valiant V8 / Barracuda V8
- W = Coronet V8 (1965)

#### 2nd Digit: Series Number

- 1 = Valiant V100, Dart 170, Belvedere I (1965), Coronet Deluxe (1965), 330 (1964), Savoy (1964), Polara (1965)

- 2 = Belvedere (1964), 440 (1964), Coronet (1965)
- 3 = Valiant V200, Dart 270, Belvedere II (1965), Coronet 440 (1965), Fury (1964), Polara (1964)
- 4 = Valiant Signet, Barracuda (1964), Dart GT, Satellite (1965), Coronet 500 (1965), Sport Fury (1964)
- 5 = Valiant V100 Wagon, Dart 170 Wagon, Belvedere I Wagon (1965), Coronet Wagon (1965), Savoy Wagon (1964), 330 Wagon (1964)
- 6 = Belvedere Wagon (1964)
- 7 = Valiant V200 Wagon, Dart 270 Wagon, Belvedere II Wagon (1965), Coronet 440 Wagon (1965), Fury Wagon (1964)
- 8 = Barracuda (1965), Belvedere Taxi (1965), Coronet Taxi (1965)
- 9 = Belvedere Police (1965), Coronet Police (1965)
- 0 = Belvedere Super Stock (1965), Coronet Super Stock (1965)

#### 3rd Digit: Model Year

- 4 = 1964
- 5 = 1965

#### 4th Digit: Assembly Plant

- 1 = Lynch Road, Detroit, MI
- 2 = Dodge Main, Hamtramck, MI
- 3 = Jefferson Avenue, Detroit, MI
- 4 = Belvedere, IL
- 5 = Los Angeles, CA
- 6 = Newark, DE
- 7 = St. Louis, MO
- 9 = Windsor, Ontario

#### 5th Through 10th Digits:

Sequential production number starting with 100001

### 1966-67 Models

1966-67 models have the Vehicle Identification Number located on a stainless steel plate riveted to the left front door hinge pillar post.

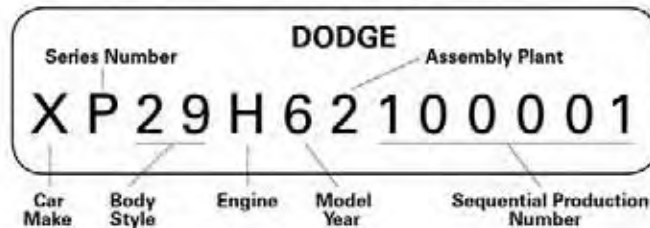

#### 1st Digit: Car Make

- B = Barracuda (1967)
- L = Dart
- R = Belvedere / Satellite
- V = Valiant
- W = Coronet
- X = Charger

#### 2nd Digit: Series Number

- E = Belvedere Fleet, Coronet Fleet
- L = Valiant 100, Dart 170, Belvedere I, Coronet Deluxe
- H = Valiant 200 (1966), Valiant Signet, Dart 270, Belvedere II, Coronet 440, Barracuda (1967)
- K = Belvedere Police, Coronet Police
- P = Barracuda (1966), Dart GT, Satellite, Coronet 500, Charger
- S = Belvedere GTX (1967), Coronet R/T (1967)
- T = Belvedere Taxi, Coronet Taxi

#### 3rd and 4th Digits: Body Style

- 21 = 2-Door Sedan
- 23 = 2-Door Coupe
- 27 = 2-Door Convertible
- 29 = 2-Door Sports Coupe
- 41 = 4-Door Sedan
- 45 = 4-Door Station Wagon (6 passenger)
- 46 = 4-Door Station Wagon (9 passenger)

#### 5th Digit: Engine

- A = 170 cid/101 hp (1966), or 115 hp (1967) 1-bbl Slant-6
- B = 225 cid/145 hp 1-bbl Slant-6
- C = Special Order Slant-6
- D = 273 cid/180 hp 2-bbl V8
- D = 273 cid/235 hp or 275 hp (1966) 4-bbl V8
- E = 273 cid/235 hp 4-bbl V8 (1967)
- E = 318 cid/230 hp 2-bbl V8 (1966)
- F = 318 cid/230 hp 2-bbl V8 (1967)
- F = 361 cid/265 hp 2-bbl V8 (1966)
- G = 383 cid/270 hp 2-bbl V8 (1967)
- G = 383 cid/325 hp 4-bbl V8 (1966)
- H = 383 cid/325 hp 4-bbl V8 (1967)
- H = 426 cid/425 hp 2x4-bbl V8 Hemi (1966)
- J = 426 cid/425 hp 2x4-bbl V8 Hemi (1967)
- L = 440 cid/375 hp 4-bbl V8 (1967)

#### 6th Digit: Model Year

- 6 = 1966
- 7 = 1967

#### 7th Digit: Assembly Plant

- 1 = Lynch Road, Detroit, MI
- 2 = Dodge Main, Hamtramck, MI
- 3 = Jefferson Avenue, Detroit, MI
- 4 = Belvedere, IL
- 5 = Los Angeles, CA
- 6 = Newark, DE
- 7 = St. Louis, MO
- 8 = Export
- 9 = Windsor, Ontario

#### 8th Through 13th Digits:

Sequential production number starting with 100001



# VEHICLE IDENTIFICATION

## CHRYSLER FENDER TAGS

Chrysler fender tags, located on the inner fender on the engine bay, can be valuable sources of information. The following is a description of fender tag characteristics, grouped by their similarities. As a general rule, fender tags are read from bottom to top and left to right.

### 1962–66 Models

The fender tags of 1962–66 cars are laid out in a very similar fashion. The scheduled build date is under the left portion of the "SO NUMBER." The number under "BDY" (body) represents the car line and model, which is the same as the first three characters of the VIN. The number under "TRM" is the interior trim code, while the exterior trim codes are found under "PNT." Sometimes the paint and trim codes are transposed, but this should be fairly obvious. The row of uppercase letters (fourth line from the bottom) represents option categories. A number under any of these letters defines an option in that letter's category. The row of numbers at the top of the tag are not yet known, but are thought to be routing, shipping, or gate information on 1962–64 models. For 1965, these numbers may represent option information in addition to routing information. Also for 1965, "A," "B" and "C" take the place of 10, 11, and 12 in the production date for October, November and December. In 1966 the row of numbers at the top are replaced by a row of lowercase letters, which are another row of option categories. A number under any of these letters represents an option in that letter's category. For information on decoding the option codes, see our selection of books by Galen Govier in the Literature section.

### 1962–65 Models

1234567890																									
⊗				10	123	⊗																			
A	B	C	D	E	F	G	H	I	J	K	L	M	N	O	P	Q	R	S	T	U	V	W	X	Y	Z
823																									
SO NUMBER					BDY		TRM		PNT																
C01 10266					125		P2R		WW1																

Build Date                      Car Line and Model      Interior                      Paint

### 1967–68 Models

For 1967 and 1968, the bottom three lines are changed completely as compared to earlier tags. The bottom line at the left starts with two letters and two numbers which identify the car line and model (same as the first four characters of the VIN). This is followed by a two-digit engine code, a one-digit transmission code, and then a three-digit tire code. Next is a three-digit build data, followed by the order number. Moving up to the third line from the bottom, numbers 1 through 8 appear here, which denote categories. A number listed under any of the category numbers defines an option in that category. To the right of the 1–8 numbers you will find "AX" for axle, "TRM" for the interior code, and "PNT" or "PAINT" for exterior colors. Continuing to the right, there is a grouping of letters "UBS." The "U" is for upper interior door color, "B" is for buffed paint and "S" is for the stripe or accent color. The codes for these are listed directly below (on the second line from the bottom). The fifth row from the bottom is a row of uppercase letters representing option categories. At the top of the tag is a row of lowercase letters also representing option categories. A number under any of these category letters defines an option in that letter's category. For information on decoding the option codes, see our selection of books by Galen Govier in the Literature section.

												Axle		Interior					Paint						
abcdefghijklmnopqrstuvwxyz																									
⊗	6		8		6																				⊗
A	B	C	D	E	F	G	H	I	J	K	L	M	N	O	P	Q	R	S	T	U	V	W	X	Y	Z
82				168								5		7		2									
12345678				AX		TRM		PNT			UBS														
				48		P6H		PP1			Q														
WS23				82		6		445		C01			01326												

Car Line and Model      Engine      Trans      Tires      Build Date      Upper Door Paint Buffed Paint Striped or Accent

### 1966 Models

abcdefghijklmnopqrstuvwxyz																									
⊗	64		4																				⊗		
A	B	C	D	E	F	G	H	I	J	K	L	M	N	O	P	Q	R	S	T	U	V	W	X	Y	Z
823																									
SO NUMBER					BDY		TRM		PNT																
C01 34182					WP27		H4X		BB1CB																

Build Date                      Car Line and Model      Interior                      Paint



With its prominent location on the driver's fender, the fender tag is usually easy to locate. 1965 and earlier cars may have it on one of the following locations: left inner fender, right inner fender, right cowl panel, left radiator core support.



# VEHICLE IDENTIFICATION

## CHRYSLER FENDER TAGS

### 1969-74 Models (Except 69-70 Lynch Rd.)

Fender tags were restyled for 1969. On the bottom line to the left, is a three-character code for the engine, followed by a three-character code for the transmission, then the actual VIN. The second line from the bottom starts with a two- or three-digit character paint code (which may be repeated) followed by a three or four character interior code (three for 1969; four for 1970 and later). Next is a two- or three-character interior upper door color or type code (two for 1969; three for 1970 and later). This is followed by the three-digit build date and the vehicle order number. The codes above these, with a couple of exceptions, are the actual selected option order codes. When moving from the bottom to the top of the tag, characters "END," "EN1" or "EN2" will appear if the code listing ends. If the factory ran out of space on one particular tag, "CTD" may appear, which means the information is continued on another tag. We've never seen more than two fender tags on any car, however.

Interior	Upper Door Paint				
⊗					⊗
V7X	END				
V1X	U	26	A33	N96	R26
FE5	D6XW	TX9	C01	276248	
E86	D21	WS23	V1B	137455	
Engine	Exterior	Trans	Build Date	V.I.N.	

### 1969-70 Lynch Road Plant

The 1969 Lynch Rd. plant fender tag is somewhat unique compared to other 1969 tags. The bottom row, to the left, has the four-character car line and model code (same as the VIN first four), followed by a three-character engine code. These are followed by a two-character transmission code, then the three-digit build date and the vehicle order number. The second line from the bottom starts with the exterior color (usually two characters) followed by a three-character interior code and a two-character upper interior door color code. Above these codes are a few selected codes, usually abbreviated actual option codes. Lynch Road tags typically list very few option codes, regardless of how the car was optioned. The fifth line from the bottom usually contains three groups of three digits for the engine, axle, and transmission build codes. The top line is not yet known. In 1970, Lynch Road tags became more like other plants, but still retained the three group, three-digit engine, axle and transmission codes on the fifth line from the bottom.

Exterior	Engine	Axle	Trans	Interior	
⊗	02134	122336	9A	192544	
	864	574	080	H51	
	26				
1X	7X				
A8	A8	C6X	X9		
XS29	E86	D21	C01	226571	
Car Line and Model	Engine	Trans	Build Date		
	Upper Door Paint				

## IDENTIFYING CHRYSLER BODY SERIES



A-Body: 1969 Barracuda

E-Body: 1970 Barracuda



B-Body: 1969 Dodge Charger

C-Body: 1970 Chrysler 300 Hurst



- A-Body: 1964-76 Valiant, 1964-69 Barracuda, 1970-76 Duster, 1972-76 Scamp, 1964-76 Dart, 1971-72 Demon, 1973-76 Dart Sport, 1969-76 Swinger
- B-Body: 1965-69 Belvedere, 1965-74 Satellite, 1968-75 Road Runner, 1970 Superbird, 1967-71 GTX, 1965-76 Coronet, 1968-71 Super Bee, 1966-77 Charger, 1969 Daytona, 1975-78 Fury, 1977-78 Monaco, 1978-79 Magnum, 1975-79 Cordoba, 1979 300
- C-Body: 1965-74 Fury I/II/III, 1975-78 Gran Fury, 1965-76 Monaco, 1977-78 Royal Monaco, 1965-73 Polara, 1965-78 New Yorker, 1965-71 300

- E-Body: 1970-74 Barracuda, 1970-74 Challenger
- F-Body: 1976-80 Volare, 1978-80 Duster, 1976-80 Road Runner, 1976-80 Aspen
- M-Body: 1982-89 Gran Fury, 1978-89 Diplomat
- J-Body: 1980-83 Mirada, 1980-83 Cordoba, 1981-83 Imperial
- R-Body: 1979-81 St. Regis, 1980-81 Gran Fury, 1979-81 Newport, 1979-81 New Yorker
- Y-Body: 1967-75 Imperial

# VEHICLE IDENTIFICATION

## Engine Code Per Body Data Tag 1966-68

Code	MYI	MYO	Engine	HP	Induction/Remarks
0.01	1966	1968	Special Order 8 CYL		
11	1966	1968	170	101	
11	1967	1968	170	115	
12	1966	1968	170	115	HD Clutch
21	1966	1968	225	145	
22	1966	1968	225	145	HD Clutch
31	1966	1967	273	180	
31	1968	1968	273	190	
32	1966	1967	273	235	
41	1966	1966	318	230	Polysphere
41	1967	1967	318	230	Canada Built
41	1967	1968	318	230	US Built
42	1966	1968	318	230	HD Clutch
51	1966	1966	361	265	
52	1968	1968	340	275	
61	1966	1967	383	270	
61	1968	1968	383	290	2V
62	66	67	383	325	4V
62	67	67	383	280	2V BH/LP
62	68	68	383	330	4V
62	68	68	383	300	4V BH/LS
62	68	68	383	335	4V RM/WM
73	66	68	426	425	2-4BBL Hemi
81	66	68	440	350	4V Single EXH
82	66	66	440	365	4V
83	67	68	440	375	4V
91	66	68	Special Order 8 CYL		

## Engine Code Per Body Data Tag 1969-71

Sales Code	MYI	MYO	CI	HP	Induction/Remarks
E11	69	69	170	115	1V
E22	70	71	198	125	1V
E24	69	71	225	145	1V
E25	69	71	225	145	1V
E31	69	69	273	190	2V
E44	69	71	318	230	2V
E55	69	71	340	275	4V
E55	70	70	340	290	6BBL/Six Pack
E57	70	71	360	255	2V
E61	69	70	360	290	2V
E61	71	71	383	275	2V
E63	69	69	383	330	4V
E63	69	70	383	330	4V
E63	70	70	383	330	4V
E63	69	69	383	335	4V
E63	70	70	383	335	4V
E63	71	71	400	190	2V
E65	71	71	383	300	4V
E74	69	71	426	425	2-4BBL
E85	69	70	440	350	4V
E85	71	71	440	335	4V
E85	69	69	440	375	4V
E85	70	70	440	380	4V
E86	69	70	440	375	4V
E86	71	71	440	370	4V
E86	69	69	440	390	6BBL/Six Pack
E87	70	70	440	390	6BBL/Six Pack
E87	71	71	440	385	6BBL/Six Pack

## Engine Codes Per Body Data Tag 1972-74

Code	MYI	MYO	CI	HP	Induction/Remarks
E22	72	72	198	94	1V w/N95 Pkg
E22	72	72	198	100	1V
E22	73	74	198	95	1V
E24	72	72	225	97	1V1V w/N95 Pkg
E24	72	72	225	110	1V
E24	73	73	225	98	1V w/N95 Pkg
E24	73	74	225	105	1V

## Engine Codes Per Body Data Tag 1972-74 (cont.)

Code	MYI	MYO	CI	HP	Induction/Remarks
E24	74	74	225	105	1V
E25	72	72	225	110	1VHD
E25	73	74	225	105	1VHD
E44	72	74	318	150	2V
E44	73	73	318	170	2V
E55	72	73	340	240	4V
E56	74	74	360	200	4V
E57	72	72	360	175	2V
E57	73	73	360	163	2V w/N95 Pkg
E57	73	73	360	170	2V
E57	74	74	360	180	2V
E58	74	74	360	245	4V
E63	72	72	400	181	2V w/N95 Pkg
E63	73	73	400	178	2V w/N95 Pkg
E63	72	72	400	190	2V
E63	73	73	400	175	2V
E63	73	73	400	185	2V
E63	74	74	400	185	2V
E64	74	74	400	200	4V
E68	72	74	400	246	4VHP w/N95 Pkg
E68	72	72	400	255	4VHP
E68	73	73	400	260	4VHP
E68	74	74	400	250	4VHP
E85	72	72	440	212	4V w/N95 Pkg
E85	72	72	440	221	4V PD w/N95 Pkg
E85	73	73	400	208	4V w/N95 Pkg
E85	72	72	440	225	4V C
E85	72	72	440	230	4V PD
E85	73	73	440	215	4V C
E85	73	73	440	220	4V
E85	74	74	440	230	4V
E86	72	72	440	245	4VHP C
E86	72	72	440	280	4VHP RW
E86	73	73	440	280	4VHP
E86	74	74	440	275	4VHP
E87	72	72	440	330	3X2VHP RW

## Engine Code Per Body Data Tag 1975-80

Code	MYI	MYO	Desc	HP	Cyl	VIN	Family
E12	78	78	1.7 LITRE	70	4	A	4CYL
E12	78	78	1.7 LITRE	75	4	A	4CYL
E12	79	80	1.7 LITRE	65	4	A	4CYL
E12	79	79	1.7 LITRE	70	4	A	4CYL
E12	80	80	1.7 LITRE	65	4	A	4CYL
E12	79	80	1.7 LITRE	65	4	A	4CYL
E24	75	80	225 1BBL	90	6	C	RG
E24	75	75	225 1BBL	95	6	C	RG
E24	76	79	225 1BBL	100	6	C	RG
E24	76	80	225 1BBL	90	6	C	RG
E25	75	80	225 1BBL		6	C	RG
E26	77	80	225 2BBL	110	6	D	RG
E27	80	80	225 2BBL		6	D	RG
E44	75	75	318 2BBL	140	8	G	LA
E44	75	75	318 2BBL	145	8	G	LA
E44	75	75	318 2BBL	135	8	G	LA
E44	75	75	318 2BBL	150	8	G	LA
E44	75	75	318 2BBL	145	8	G	LA
E44	75	75	318 2BBL	150	8	G	LA
E44	76	76	318 2BBL	140	8	G	LA
E44	76	76	318 2BBL	150	8	G	LA
E44	77	77	318 2BBL	135	8	G	LA
E44	77	77	318 2BBL	145	8	G	LA
E44	77	77	318 2BBL	135	8	G	LA
E44	78	78	318 2BBL	140	8	G	LA
E44	78	78	318 2BBL	145	8	G	LA
E44	78	78	318 2BBL	140	8	G	LA
E44	78	78	318 2BBL	140	8	G	LA
E44	79	79	318 2BBL	135	8	G	LA

# VEHICLE IDENTIFICATION

**Engine Code Per Body Data Tag 1975-80 (cont.)**

Code	MYI	MYO	Desc	HP	Cyl	VIN	Family
E44	80	80	318 2BBL	120	8	G	LA
E45	78	80	318 2BBL	180	8	G	LA
E46	78	80	318 4BBL	155	8	H	LA
E47	79	80	318 4BBL	155	8	H	LA
E48	80	80	318 4BBL	155	8	H	LA
E56	75	75	360 4BBL	190	8	J	LA
E56	76	76	360 4BBL	175	8	J	LA
E56	77	77	380 4BBL	155	8	J	LA
E56	79	80	360 4BBL	195	8	J	LA
E57	75	75	360 2BBL	180	8	K	LA
E57	76	76	380 2BBL	170	8	K	LA
E57	77	78	360 2BBL	155	8	K	LA
E57	79	79	360 2BBL	150	8	K	LA
E57	80	80	360 2BBL	130	8	K	LA
E58	75	75	360 4BBL	230	8	L	LA
E58	76	76	360 4BBL	220	8	L	LA
E58	77	78	360 4BBL	160	8	L	LA
E58	77	78	360 4BBL	175	8	L	LA
E58	78	78	360 4BBL	160	8	L	LA
E58	79	79	360 4BBL	190	8	L	LA
E58	79	79	360 4BBL	195	8	L	LA
E58	80	80	360 4BBL	185	8	L	LA
E83	75	76	400 2BBL	165	8	M	B

**Engine Code Per Body Data Tag 1975-80 (cont.)**

Code	MYI	MYO	Desc	HP	CYL	VIN	FMLY
E63	75	76	400 2BBL	175	8	M	B
E64	75	75	400 4BBL	185	8	N	B
E64	75	75	400 4BBL	190	8	N	B
E64	75	75	400 4BBL	195	8	N	B
E64	76	76	400 4BBL	210	8	N	B
E64	77	78	400 4BBL	190	8	N	B
E68	75	75	400 4BBL	235	8	P	B
E68	75	75	400 4BBL	240	8	P	B
E68	76	76	400 4BBL	240	8	P	B
E68	77	78	400 4BBL	190	8	P	B
E85	75	75	440 4BBL	210	8	T	RB
E85	75	75	440 4BBL	215	8	T	RB
E85	76	76	440 4BBL	200	8	T	RB
E85	76	76	440 4BBL	205	8	T	RB
E85	77	78	440 4BBL	185	8	T	RB
E85	77	78	440 4BBL	195	8	T	RB
E85	77	78	440 4BBL	185	8	T	RB
E86	75	75	440 4BBL	260	8	U	RB
E86	75	75	440 4BBL	265	8	U	RB
E86	76	76	440 4BBL	250	8	U	RB
E86	76	76	440 4BBL	255	8	U	RB
E86	77	78	440 4BBL	185	8	U	RB
E86	77	78	440 4BBL	195	8	U	RB



# VEHICLE IDENTIFICATION

## ENGINE COMPONENT CASTING NUMBERS

### Engine Block Casting Numbers

#### A/LA Small Blocks

Casting No.	CID	Year	Family	Remarks
2465330	273	1964-66	LA	
2536130	273	1965	LA	
2463252	273		LA	
2465330	273	1964-66	LA	
2536130	273	1965	LA	
2806030	273	1966-69	LA	
2806130	273	1965-69	LA	
2466090	318		LA	
2536030-318	318	1967-75	LA	
2566080	318		LA	
2806030	318	1967-74	LA	
2466090	318		LA	
2536030-318	318	1967-75	LA	
2566080	318		LA	
2806030	318	1967-74	LA	
4104230-318	318	RACE ENGINE	LA	Painted Orange
2264230	318	1960-66	A	
2468230	318		A	
2532630-318	318		A	
2264230	318	1960-67	A	Polysphere
2468230	318		A	Polysphere
2532630-318	318		A	Polysphere
2780930-340	340	1968-73	LA	
3577130TA-340	340	1970-71	LA	Trans Am
2780930-340	340	1968-73	LA	
3577130TA-340	340TA	1970-71	LA	Trans Am
3418496-360	360	1971-74	LA	
3870230	360	1975-Up	LA	
3418496-360	360	1971-74	LA	
3870230	360	1975-78	LA	
4179930-360	360	1975-93	LA	

#### B Big Blocks

Casting No.	CID	Year	Family	Remarks
2120229	361		B	Industrial
2205712	361	1958-66	B	
2120229	361		B	Industrial
2120429	361		B	
2205712	361	1958-66	B	
2858930	361	1965	B	
2128854	361+383	1964	B	
2468130	383	1959-71	B	
2468130	383	1959-71	B	
2532130	383	1965	B	
2899830	383	1970	B	
3614230	400	1971-72	B	
3698630	400	1973-78	B	
4006530-400-12	400	1976-78	B	
3614230	400	1971-72	B	
3698630	400	1973-78	B	
4006530-400	400	1976-78	B	

#### RB Big Blocks

Casting No.	CID	Year	Family	Remarks
2120329	383	1959-60	RB	Golden Lion
1852029	413	1962	RB	Max Wedge
2120529	413	1959-65	RB	
2205697	413	1959-65	RB	Pass Car
2468030	413		RB	
1851629	413	1961	RB	
1852029	413	1962	RB	Med. Duty Truck
MAX PERF				
1852029	413	1962-63	RB	Med. Duty Truck
2120529	413	1959-65	RB	

#### RB Big Blocks (cont.)

Casting No.	CID	Year	Family	Remarks
2406730	426	1963-65	RB	Wedge
2205697	413+426	1959-65	RB	Passenger Car
2468030	413+426		RB	Wedge
2468330	426	1964-71	RB	Hemi
2658836	426		RB	Industrial
1852029	426	1962-65	RB	Wedge
2406730	426	1963-65	RB	Wedge + Max Perf
2440873	426		RB	Wedge
2532230	426	1964-66	RB	Wedge, Max Perf + Industrial
2658836	426		RB	Industrial
2536430	440	1966-72	RB	
3698830-440	440	1973-78	RB	
2536430	440	1966-72	RB	
3698830-440	440	1972-78	RB	
4006630-440	440	1975-78	RB	

#### 426 Hemi Blocks

Casting No.	CID	Year	Family	Remarks
2468330-1 or 2	426	1964-65	RB	Race Hemi Distributor Area=Rounded
2468330-1 or 2	426	1966-71	RB	Street Hemi Distributor Area=Squared

#### Engine Stampings

##### Decoding Vehicle Serial Number on the Engine

Starting in 1968, all engine and major driveline components are stamped with the Vehicle Identification Number (VIN) as a theft deterrent. During the first two years (until 1970), Chrysler usually stamped the entire number on the rail. From 1970 on, they stamped only the last eight digits on the engine. Slant-6 engines have this number stamped below the cylinder head on the passenger side of the block. V8 engines are stamped on the driver's side upper rear of the block in 1968, and above the passenger side oil pan rail near the motor mount on 1969-and-later engines. Most warranty engines will not have this stamping (although the technicians were supposed to restamp them after replacement).

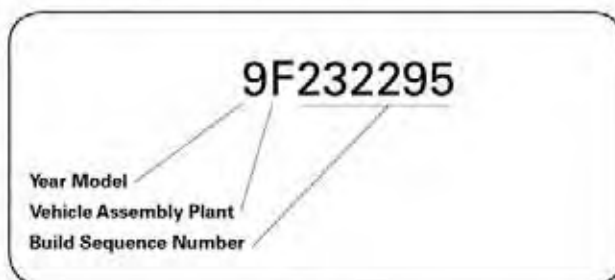

#### 1968-74 Vehicle Assembly Plant Codes

A = Lynch Road, Detroit, MI      F = Newark, DE  
 B = Dodge Main, Hamtramck, MI      G = St. Louis, MO  
 C = Jefferson Avenue, MI      H = New Stanton, PA (1970-71)  
 D = Belvidere, IL      P = Export (1968)  
 E = Los Angeles, CA (1968-71)      R = Windsor, Ontario

#### Engine Serial Number

The serial number is a sequence of 14 digits that contains a wealth of information all in one location. A few problems must be answered first, such as where it is found and what it means. Occasionally, for whatever reason, an engine will not have a serial number stamped on it. This seems to be fairly common, so if yours doesn't, it's not that big of a deal. On slant-6 engines the number is stamped on the block, below the head near the ignition coil. Small blocks seem to have their own story—a sequence of numbers will almost always be present, but they don't always follow this particular serial number pattern. For small blocks, look on the front face of the block, below the driver's side cylinder head (see the small-block ID Boss explanation for more information). For B and RB big blocks, the number is typically found along the oil pan rail, close to or under the starter. These are hand-stamped numbers, so visibility and consistency are not always the greatest.

## PM400E37320016

Characters 1-2	Plant ID code
Characters 3-5	Cubic inch displacement
Character 6	Additional build information (mostly letters)
Characters 7-10	10,000 day calendar date
Characters 11-14	Engine production number that cycle

**NOTE:** There may be other characters after these, but they have not been decoded and do not appear to be meaningful to restorers at this time.

### Engine Stampings

The easiest way to determine what engine you're looking at is by locating and decoding the stampings on the ID boss. This machined pad includes the displacement, build date, and other special information relating to that particular engine. The information on the pad is hand-stamped and may be difficult to read without cleaning the area. But, since this is the simplest way to identify various Chrysler engines, it's worth the trouble. The location of the pad varies on small block, "B" and "RB" engines, and they're listed below.

### Small Block ID Boss

Small Block: Locating the ID pad on a small block is the simple part—decoding the information is where it gets tricky. The pad is found on the driver's side front of the block below the cylinder head on both "A" and "LA" small blocks. With the engine in the car and all the accessories in place, it may be hard to see, but it's there.

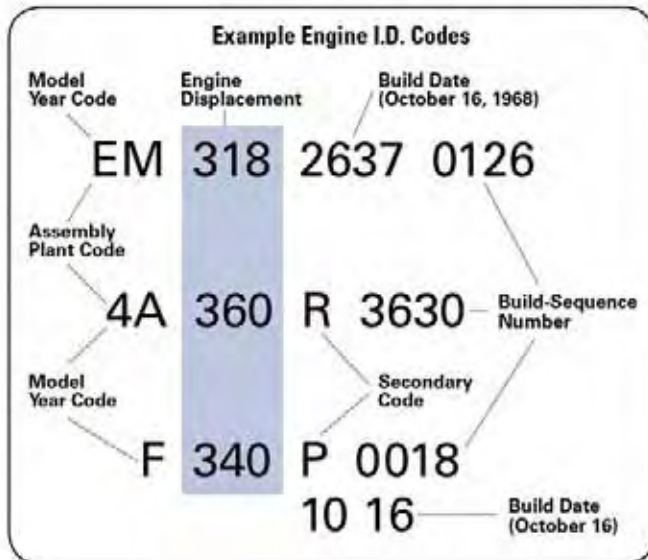

### Secondary Codes

Here is a listing of the additional, or secondary, information codes and their meanings. These are found on the ID boss or sequence number of your engine. In the case of small blocks, some of these symbols might be found on the affected part (0 on the tappet boss; anything crank related is on the No. 8 counterweight). Although this list is as complete as we can make it, there may be other codes or symbols not listed here. ID boss decoding is an ongoing project and new information is occasionally found.

T	Truck
R	Regular Fuel
P	Premium Fuel
LC	Low Compression
HC	High Compression
MP	Maximum Performance
HP, HP2.	High Performance
⊗	.001" Undersize Crank
⊗ and X	.010" Undersize Crank
◇	.008" Oversize Tappets
O.S.	.005" Oversized Valve Guides
X	Oversize Valve Guides
S	Special Engine (possibly warranty)
SP	Special Engine (TA340 or police)
WT	Water Tested
H	Hemi (before displacement: H426)
A	.020" Oversize Cylinder Bore
B	.010" Undersize Main and Rod Bearings
E	Cast Crank
H	Standard 4-bbl V8

## VEHICLE IDENTIFICATION



## B/RB Big Block and Hemi ID Boss

Big Block: Locating the ID pad on big blocks is the easiest way to distinguish a "B" engine from an "RB" engine. On "B" engines, the ID pad is located on the passenger's side of the engine, just below the cylinder head next to the distributor base; on "RB" or Hemi engines, the ID pad is located on top of the block directly in front of the intake manifold valley pan, next to the distributor base toward the driver's side.

The first letter is the year code, followed by the engine's displacement. Hemi engines have an "H" after the year letter and before the displacement, while truck blocks have a "T" in this location. Engine displacements before 1965 may have a digit missing. For example: 36=361, 38=383, 41=413.

**EH426**  
**1 - 16 - 06**  
**A P** ◊

This line contains the build date and the number engine that was built that day.

- The first number is the month (or a fourth digit, 10,000-day calendar date).
- The second number is the day of the month (or a fourth digit, 10,000-day calendar date).
- The third number is the build sequence for that day. This example engine was the sixth built.

The last line carries any secondary information pertaining to the build of the engine. Any symbol or letter on this line had a special meaning. This example engine has an A (oversize cylinder bores), P (premium fuel only) and ◊ (oversize tappets).

## Model Year Codes

The following is a list of letter codes and their corresponding years. The year always precedes the engine displacement.

P = 1960	A = 1965	F = 1970	K or 4 = 1974
R = 1961	B = 1966	G = 1971	L or 5 = 1975
S = 1962	C = 1967	H = 1972	M or 6 = 1976
T = 1963	D = 1968	J = 1973	N or 7 = 1977
V = 1964	E = 1969		

## Assembly Plant Codes

K =	Toluca
M or PM =	Mound Rd.
MV or MN =	Marysville
T or PT =	Trenton
W =	Windsor



## Cylinder Heads

Head casting numbers can be found in two places on both big- and small-block engines. The first is under the valve cover, where you'll find a complete number as well as other casting information like the date and clock. These numbers may be covered in hardened, burned oil (a.k.a. "coke"), which may make them hard to read. The head must be off the engine to find the second position, which is located on the combustion chamber side of the head on the runners.

Casting No.	CID	Year	Remarks
2206324	361, 383, 413	61-62	
2206924	361, 383, 413	62	
2402557	413	63	
2206035	170, 225	62-63	
226341	318	62-67	
2402286	413	62	Stage I
2406516	361, 383, 413	64-65	
2406516	426	64-66	Street Wedge
2406516	413	65	300L
2406516	383	66-67	
2408520	413	64	300K
2408518	426	64	Stage III
2463209	426	63	Stage II
2463200	361, 383, 413	63	
2206035	170, 225	64-66	
2465315	273	64-65	
2468016	426 HEMI	64	Cast K Head
2531110	426 HEMI	65	Aluminum "Alcoa"
2531695	426 HEMI	65	Rev B "Alcoa"
2531718	426 HEMI	A148	
2531894	340	68-70	X
2532080	273	64-65	
2536178	273	66	Early
2658234	273	66	Late
2658920	273-4	66	
2780559	426 HEMI	66-71	Cast Iron
2780559	426 HEMI		Cast Iron, Twin Plug
2406158	383-440	67	Non-HP
2780915	383-440	67	1.6 Exh Valve = Non-HP
2780915	440	67	1.74 Exh Valve = HP
2658920	273-318	67	
2658920	273	66	
2843675	273	68-69	
2843675	318	68-71	
2843189	170-225	66-69	
2843169	198, 225	70-71	
2843169	198, 225	74	
2843906	383, 440	68-70	
2945270	426 HEMI	03	
2951250	383, 440	68	
3418915	360	70-71	Z or O 1.88 Int Valve
3418915	340	71	J or U 2.02 Int Valve
3418915	340	70	U or O 2.02 Int Valve
3418915	340, 360	71-72	J 1.88 Int Valve
3462346	383, 400, 440	71-72	
3462346	400, 440	73	
3462598	340	70	AAR, TA
3512015X	426 HEMI	04	Cast Iron
3698995	198, 225	72	
3614850	198, 225	72-73	
2843675	318	72-74	
3671587	360	73-74	
3671587	340	73	
3614433	426 HEMI		Aluminum
3614476	B/RB		Stage IV
3751213	400, 440	73	Motor Home
3769902	400, 440	74	

## VEHICLE IDENTIFICATION





# VEHICLE IDENTIFICATION

## Intake Manifold

Finding the intake manifold casting number is fairly simple. Usually, the casting number is on top of the manifold, close to the carburetor mounting pad. Occasionally it's on the bottom of the manifold, which can pose an identification problem if it's still installed on the engine.

Cast No.	Metal	Year	Body	Engine	Remarks
1733878	Alum	1956-57	C	303 2-4	Fury
1735917	Alum	1956-57	C	315 2-4	500 "A" Option
1822004	Inline	1957-58	C	318 2-4	WCFB 4BBLs
1851898		1959-60	C	383 1-4	RB-Engine
1851899		1959-60	C	383 1-2	RB-Engine
1859229		1957-61	C	318 1-4	WCFB 4BBL
2264877	Inline	1959-61	C	413 2-4	300 E-F-G
1827899	Inline	1958	C	350 2-4	
1827899	Inline	1959-61	C	383 2-4	343 HP
1947162	Alum	1961	C	383+413 2-4	Left
1947163	Alum	1961	C	383+413 2-4	Right
2129898	Alum	1960-62	A	170+225 1-4	Hyper Pak
1859229		1962	B	318 1-4	
2205968		1962	B	361 1-4	
2205968		1962	B	383 1-4	
1827899	Inline	1962	B	383 2-4	343 HP
2206000		1962	B	413 1-4	D2, P2
2206000		1962	C, D	413 1-4	C2, C3, Y1
2264877	Inline	1962	B	413 2-4	385 HP
2264877	Inline	1962	C	413 2-4	300-H
2402726	Alum	1962	B	413 2-4	Max Perf I
2205968		1963	B	383 1-4	
2206000		1963	C, D	413 1-4	Exc. 300-J
2129985	Alum	1963	C	413 2-4	300J Right
2129987	Alum	1963	C	413 2-4	300J Left
2402726	Alum	1963	B	426 2-4	Max Perf I
2402728	Alum	1963	B	426 2-4	Max Perf II
2205968		1964	B	383 1-4	
2206000		1964	C, D	413 1-4	
2129985	Alum	1964	C	413 2-4	300K Right
2129987	Alum	1964	C	413 2-4	300K Left
2402728	Alum	1964	B	426 2-4	Max Perf III
2406185	Alum-B	1964	B	426 1-4	Max 1-PL Short
2465165	Alum-B	1964	B	426 1-4	Max 2-PL Short
2468045	Alum	1964	B	426 2-4	S/S Hemi Strip
2206000		1964	B	426 1-4	Street Wedge
2468043	Holley	1964	B	426 1-4	Hemi NAS-Track
2465726		1965	A	273 1-4	
2205968		1965	B, C	383 1-4	
2206000		1965	C, D	413 1-4	
2538900	Mag	1965	B	426 2-4	S/S Hemi Strip
2206000		1965	B, C	426 1-4	Street Wedge
2531631	Rat Roadster		B	426 1-4	Hemi/Holley
2948278	Inline Inverted		B	426 2-4	Hemi/Holley
2536563		1966	A	273 1-4	HP
2536636		1966		273 1-4	Marine
2536771	w/C.A.P.	1966	A	273 1-4	HP
2205968		1966	B, C	383 1-4	
2531921	Inline	1966	B	426 2-4	Hemi/Holley
2780543	w/DPCD	1966			
2780544	w/Hole	1966	B	426 2-4	Hemi/Carter
2206000		1966	C, D	440 1-4	
2536563		1967	A	273 1-4	HP
2536771	w/C.A.P.	1967	A	273 1-4	HP
2846346				273 1-4	Marine
2205968		1967	ABC	383 1-4	HP
2780543	w/DPCD				Early
2780544	L/Hole	1967	B	426 2-4	Hemi/Carter
2780543					
2780544	Wall Cut	1967	B	426 2-4	S-Stock
2780543	w/Pentstar				Late
2780544		1967	B	426 2-4	Hemi/Carter
2536900		1967	B	426 2-4	Hemi NASCAR
2806178		1967	B	440 1-4	HP



## Intake Manifold (cont.)

Cast No.	Metal	Year	Body	Engine	Remarks
2531915		1968	A	340 1-4	HP
2806301		1968	ABC	383 1-4	
2780543	w/Pentstar				
2780544		1968	B	426 2-4	Hemi/Inline
2536900	Mag	1968	A	426 2-4	Hemi/Crossram
3531960			Parts	440 1-4	
2806178		1968	B/C	440 1-4	
2531915		1969	A	340 1-4	HP
2846704				340 1-4	Marine
2806301		1969	ABC	383 1-4	
2780543	w/Pentstar				
2780544		1967	B	426 2-4	Hemi/Inline
2806178		1969	ABC	440 1-4	
3412046	Alum	1969	B	440 3-2	Edelbrock
3462848		1970	A, E	340 1-4	
3418681	Alum	1970	E	370 3-2	Edelbrock
3418681	Alum	PARTS		340 3-2	Edelbrock
2951666		1970	BCE	383 1-4	
2780543	w/Pentstar				
2780544		1970	BE	426 2-4	Hemi/Inline
2951736		1970	BCE	440 1-4	
2946275	Iron	1970	BCE	440 3-2	Early
2946276	Iron	1970	BCE	440 3-2	Late
3412046	Alum	1970	BE	440 3-2	Edelbrock
3512100		1971	ABE	340 1-4	
3549885	Alum	PARTS		340 1-4	Edelbrock
2951666		1971	BCE	383 1-4	
2780543	w/Pentstar				
2780544		1971	BE	426 2-4	Hemi/Inline
3512501		1971	BC	440 1-4	Exc. Imperial
		1971	C	440 1-4	Imperial
2948276	Iron	1971	BCE	440 3-2	
3614025		1972	ABE	340 1-4	Less N95
3671918		1972	ABE	340 1-4	With N95
3614046		1972	BC	400 1-4	Less N95
		1972	BC	400 1-4	With N95
3614014		1972	BC	440 1-4	Less N95
		1972	BC	440 1-4	With N95
		1972	BC	440 1-4	Less N95
		1972	BC	440 1-4	With N95
2948276	Iron	1972	B	440 3-2	Very Early
3671918	w/EGR	1973	ABE	340 1-4	
3671879		1973	BC	400 1-4	
3698444		1973	BC	440 1-4	Exc. Imperial
		1973	C	440 1-4	Imperial
3698434		1974	ABE	360 1-4	
3694882		1974	BC	400 1-4	
3751728		1974	BC	440 1-4	
3690187		PARTS	B	440 3-2	Edelbrock



# PART NUMBER INDEX

02495531	112	77060010AB	235	77060080	194	77R06021	144
02534814	141	77060011AB	235	77060081	235	77R06032	152
02823848	159	77060012AB	194, 235	77070001	257	77R06034	149
02823849	159	77060013AB	235	77070002	194	77R06036	146
02983067	141	77060019AB	194	77070004	235	77R06037	146
03404404	141	77060020AB	235	77070005	194	77R06038	146
03416002	147	77060022AB	194	77070006	235	77R06039	145
03418658AB	149	77060030	262	77070008	194	77R06040	145
03431074	141	77060031	262	77070010	177, 194, 236	77R06041	145
03454390	149	77060032	262	77070011	177, 194	77R06042	145
03454391	149	77060033	262	77070012	177, 194, 236	77R06043	145
03467764	125, 146	77060034	263	77070013	236	77R06045	145
03587436	152	77060035	263	77070014	236	77R06046	145
03587440	152	77060038	267	77070015	177, 194, 236	77R06049	148
03672933	148	77060039	267	77070016	177, 194	77R06050	148
03739844	149	77060042	263	77070017	236	77R06051	146
03747092	110	77060043	263	77070018	236	77R06052	149
04293102	146	77060044	263	77070019	194	77R06053	148
04338855	18, 123	77060045	263	77070023	235	77R06054	148
04606487AB	17	77060046	264	77070027	235	77R06055	148
04852396AB	184	77060047	264	77070028	235	77R06056	145
04861552AC	17	77060048	266	77070029	176	77R06057	145
04884447AA	184	77060049	266	77070030	235	77R06059	145
04897646AA	270	77060050	266	77070032	176	77R06060	145
05017479AA	17	77060051	266	77070038	177, 194	77R06061	145
05029257AA	197	77060052	267	77DUB01002	198	77R06062	149
05038307AE	167	77060053	267	77DUB01008	198	77R06064	150
05045164AC	224	77060054	264	77DUB01010	179	77R06065	150
05045291AB	223	77060055	264	77DUB01020	179	77R06066	153
05045292AA	224	77060056	265	77DUB01021	179	77R06067	148
05045404AA	224	77060057	265	77DUB01022	179	77R06068	147
05045406AA	224	77060058	265	77DUB01023	257	77R06069	147
05134116AC	198	77060059	265	77DUB01030	179	77R06071	147
05278944AD	198	77060060	262	77DUB01040	179	77R06072	147
52087542	18, 123	77060061	262	77DUB02000	179	77R06073	151
52107555	18, 123	77060062	270	77DUB03000	179	77R06074	151
52107625	18, 123	77060063	270	77DUB04000	179	77R06075	151
53008342	18, 123	77060064	270	77DUB07000	180	77R06078	152
56041018AD	17	77060065	270	77DUB07010	180	77R06081	154
68101616AA	224	77060066	270	77DUB08000	180	77R06082	145
77060003AC	176	77060067	270	77DUB09000	179	77R06083	145
77060004AB	194	77060068	270	77DUB09010	179	77R06084	145
77060005AC	235	77060069	270	77DUB10100	179	77R06085	152
77060006AB	176	77060070	270	77DUB10200	179	77R06086	151
77060007AB	235	77060071	270	77DUB10300	179	77R06087	152
77060008AB	235	77060072	270	77DUB10400	179	77R06088	152
77060009AB	235	77060073	270	77R06002	145	77R06089	152

# PART NUMBER INDEX

77R06090	152	77R06156	141	77R06280	153	P0009007EB	274
77R06091	152	77R06157	142	77R06281	153	P0009007SU	274
77R06092	152	77R06158	142	77R06282	153	P0009145ST	275
77R06093	152	77R06159	142	77R06283	105	P000921STS	275
77R06094	104, 140	77R06160	142	77R06284	147	P001156STS	275
77R06095	151	77R06161	117	77R06285	114	P003157STS	275
77R06096	152	77R06162	142	77R06286	114	P0046024ST	274
77R06097	152	77R06163	142	77R06287	142	P007506STS	275
77R06098	152	77R06164	142	77R06289	145	P00H6054ST	274
77R06099	152	77R06165	142	77R06290	145	P09005XSST	274
77R06100	151	77R06166	141	77R06291	145	P1737725	109
77R06101	147	77R06167	142	77R06292	142	P1828352	141
77R06102	156	77R06168	142	77R06293	142	P2120930	29, 48, 77
77R06104	150	77R06170	140	77R06294	142	P2206445	114
77R06105	150	77R06171	140	77R06295	102	P2444641	110
77R06107	150	77R06172	140	77R06296	144	P2497502	141
77R06108	150	77R06173	140	77R06297	144	P2579655	157
77R06110	150	77R06175	140	77R06298	144	P2579656	157
77R06111	150	77R06176	158	77R06299	144	P2579657	157
77R06112	150	77R06177	147	77R06300	144	P2579658	157
77R06113	150	77R06178	147	77R06301	144	P2658931	143
77R06114	150	77R06179	158	77R06302	144	P2782966	156
77R06115	150	77R06180	158	77R06303	144	P2785434	144
77R06116	150	77R06182	140	77R06304	144	P2785518	156
77R06117	150	77R06183	140	77R06305	144	P2785579	156
77R06122	153	77R06184	140	77R06306	144	P2785791	156
77R06123	148	77R06185	140	77R06307	144	P2786711	156
77R06124	145	77R06256	153	77R06308	144	P2801243	117
77R06126	145	77R06257	153	77R06309	144	P2806077	33, 54, 87
77R06127	145	77R06258	153	77R06310	144	P2806186	143
77R06128	151	77R06259	153	77R06311	144	P2809011	141
77R06129	151	77R06260	154	77R06312	105	P2841886	156
77R06130	148	77R06261	154	77R06313	104	P2842756	155
77R06131	148	77R06262	154	P00000H7EB	274	P2842757	155
77R06134	148	77R06263	154	P00000H7ST	274	P2842758	155
77R06135	144	77R06266	154	P0000880ST	275	P2842873	155
77R06136	144	77R06267	154	P0000893ST	275	P2843177	28, 49, 77
77R06139	144	77R06268	154	P0000H13ST	274	P2863201	143
77R06143	158	77R06271	154	P0000HIDD1	274	P2863230	143
77R06144	158	77R06272	151	P0000HIDD2	274	P2863244	143
77R06149	148	77R06273	153	P0009004EB	274	P2863245	143
77R06150	142	77R06274	153	P0009004SU	274	P2863256	143
77R06151	141	77R06275	153	P0009005EB	274	P2863257	143
77R06152	141	77R06276	153	P0009005ST	274	P2879600	147
77R06153	142	77R06277	153	P0009005SU	274	P2889803	141
77R06154	142	77R06278	153	P0009006EB	274	P2898886	156
77R06155	141	77R06279	153	P0009006SU	274	P2901812	156

# PART NUMBER INDEX

P2925322	141	P3462184	143	P3690855	119	P4120211AB	91
P2932675	108	P3462193	143	P3690874	94	P4120231AC	75
P2932820	117	P3462491	157	P3690875	38, 59	P4120233AC	75
P2946105	81, 143	P3462492	157	P3690876	38, 59	P4120235AC	47
P2946353	33, 87	P3467766	125, 146	P3690896	35, 89	P4120237AC	47
P2946393	103	P3504289	156	P3690933	33, 54, 87	P4120241	119
P2947953	147	P3504807	156	P3690936	29, 49	P4120249	87
P2949303	156	P3505419	155	P3690939	94	P4120272	52, 83
P2964635	156	P3505490	156	P3690944	94	P4120280	117
P2998042	156	P3505491	156	P3690963AB	85	P4120294	112
P2998065	156	P3571071	38, 59	P3691468	157	P4120353	31
P2998326	144	P3573632	156	P3691667	156	P4120437	51
P2998547	157	P3574059	156	P3749059	155	P4120446	84
P2998749	156	P3577086	89	P3760214	149	P4120456	81, 186
P2998796	157	P3580466	158	P3760215	149	P4120459	81
P2998798	157	P3612874	155	P3830183	26, 43	P4120461	119
P2998800	157	P3613278	156	P4006767	28, 49	P4120462	119
P2998801	157	P3614321	77	P4007039AB	101	P4120468	128
P2998802	157	P3614542	87	P4007040	101	P4120469	128
P2998804	157	P3672656	155	P4007178	86	P4120470	133
P2998896	158	P3680160	156	P4007291	116	P4120471	81
P3151736	141	P3680304	155	P4007570AB	91	P4120472	51
P3412002	132	P3690152	110	P4007571AB	91	P4120484	101, 207, 223
P3412003	132	P3690181	135	P4007572	94	P4120492	53, 85
P3412049	37, 58	P3690182	135	P4007573	94	P4120505	110
P3412064	38, 59	P3690426	109	P4007612	136	P4120534	110
P3412068	87	P3690427	109	P4007667	111	P4120589	89
P3412083	25	P3690428	109	P4007886AB	119	P4120603	94
P3412423	158	P3690430	108	P4007899	116	P4120610	158
P3412427	158	P3690431	108	P4007968	110	P4120611	134
P3431154	141	P3690432	108	P4022410	155	P4120612	134
P3431590	141	P3690454	132	P4022411	155	P4120613	37, 58, 93
P3443159	157	P3690455	132	P4120074	134	P4120618	53, 86
P3443247	157	P3690456	132	P4120075	134	P4120619	86
P3443516	156	P3690457	132	P4120076	134	P4120625	158
P3443627	156	P3690460	132	P4120077	133	P4120626	53, 86
P3444927	156	P3690461	132	P4120078	133	P4120634	32
P3444938	157	P3690560	113	P4120079	133	P4120635	32, 86
P3445223	157	P3690715	94	P4120080	133	P4120653AC	76
P3446861	155	P3690730AB	119	P4120081	133	P4120655AC	76
P3461066	158	P3690731	113	P4120086	36	P4120657AC	76
P3461458	158	P3690732	113	P4120093	81	P4120659AC	47, 48
P3462113	143	P3690753	130	P4120094	81, 222	P4120661AC	47, 48
P3462114	143	P3690754	130	P4120101	52	P4120663AC	47, 48
P3462116	143	P3690755	130	P4120105	133	P4120665AB	134
P3462119	143	P3690773	128	P4120161AB	119	P4120692	69
P3462165	143	P3690774	128	P4120210AB	91	P4120714AB	128

# PART NUMBER INDEX

P4120751AB	143	P4349217AB	143	P4452778	100	P4510280	238
P4120752AB	143	P4349218AB	143	P4452779	100	P4510281	25
P4120753AB	143	P4349228	100	P4452782AC	75	P4510282	25
P4120758	40, 61, 96	P4349235	102	P4452783AC	47	P4510283	25
P4120785	33, 54, 86	P4349236	102	P4452785	119	P4510284	25
P4120808	112	P4349237	102	P4452787	130	P4510285	25
P4120863	132	P4349238	102	P4452795	27, 44	P4510286	25
P4120864	132	P4349239	102	P4452803	184	P4510287	25
P4120865	132	P4349241	102	P4452804	184	P4510288	25
P4120866	132	P4349268AC	47, 48	P4452816	70	P4510289	25
P4120868	186	P4349278	108	P4452827	34	P4510316	212
P4120889	113	P4349279	108	P4452889	195	P4510317AB	212
P4120964	198	P4349304	100	P4452890	38, 59, 95	P4510318	100
P4120998	37, 59	P4349321	102	P4452919	77	P4510319	101
P4271961	25, 42	P4349469AB	116	P4452920	28, 49	P4510342	17
P4286569	91	P4349540	252	P4452982	132	P4510356	17
P4286571	38, 58	P4349557	81, 222	P4452983	132	P4510357	17
P4286574	187	P4349559	51	P4452984	132	P4510358	15
P4286589	94, 223	P4349620	52	P4452985	132	P4510363	202
P4286590	38, 59	P4349628	95	P4452986	133	P4510364	238
P4286612	53, 86	P4349629	59	P4452987	133	P4510447	189
P4286677AC	47	P4349632AB	83	P4452992AC	75	P4510454	190
P4286728	113	P4349633AB	52	P4452993AC	47	P4510455	190
P4286740	241	P4349650	186	P4510054	117	P4510457	190
P4286741	195	P4349736	186	P4510063	184	P4510458	190
P4286754	51	P4349816	27, 44	P4510144	170	P4510459	190
P4286759	40, 60, 96	P4452005	186	P4510168	168	P4510460	190
P4286765	186	P4452006	186	P4510169	169	P4510461	196
P4286766	186	P4452025	96	P4510171	164	P4510463	196
P4286775	33, 54, 86	P4452030	187	P4510172AB	164	P4510464	240
P4286776	187	P4452031	187	P4510176	165	P4510465	240
P4286800	38, 60, 95	P4452032	86, 187, 232	P4510177	167	P4510466	237
P4286812	33, 54, 87	P4452033	54, 86	P4510179	169	P4510467	237
P4286813	87	P4452089	82, 83	P4510204	170	P4510468	237
P4286825	57	P4452091	52	P4510224	167	P4510469	237
P4286826	57	P4452093	94	P4510225	167	P4510472	195, 236
P4286868	135	P4452097	94	P4510233	167	P4510473	236
P4286869	135	P4452099	37, 58	P4510261	190	P4510474	236
P4286870	135	P4452101	91	P4510262	190	P4510475	236
P4286900	39, 60	P4452103	57	P4510263	197	P4510476	195
P4348719	117	P4452105	57	P4510268	132	P4510478	195
P4349052	197	P4452162	197	P4510269	132	P4510481	195
P4349116	136	P4452757AC	75	P4510272	257	P4510486	197
P4349121	187	P4452759AC	75	P4510273	257	P4510529	184
P4349125	187	P4452761AC	75	P4510274	257	P4510538	188
P4349147	186	P4452767	185	P4510275	257	P4510543	191
P4349216AB	143	P4452769	33, 54	P4510277	257	P4510548	184

# PART NUMBER INDEX

P4510554	184	P4510823	189	P4529025	104	P4529190	39, 59, 95
P4510559	270	P4510825	188	P4529032	111	P4529214	233
P4510560	270	P4510826	191	P4529038	32	P4529215	233
P4510567	270	P4510827	191	P4529054	91	P4529217	232
P4510577	31	P4510828	191	P4529055	56	P4529218	233
P4510579	158	P4510829	238	P4529056	56	P4529220AB	80, 231
P4510581AB	14	P4510833	177	P4529057AB	103	P4529221	232
P4510582AB	14	P4510836	189	P4529058	103	P4529227	241
P4510586	188	P4510837	189	P4529059	103	P4529228AD	231
P4510587	188	P4510839	190	P4529060	102	P4529229AD	231
P4510588	197	P4510841	181	P4529061	103	P4529240	233
P4510596	185	P4510842	181	P4529064	124	P4529241	241
P4510598	270	P4510845	14	P4529070AB	26, 43, 70, 231	P4529242	231
P4510607	240	P4510853AB	280	P4529071	105	P4529243	233
P4510608	171	P4510854	180	P4529072	105	P4529245	230
P4510609	196	P4510855	178	P4529073	105	P4529256	71, 96
P4510610	125	P4510856	240	P4529074	105	P4529264	103
P4510611	125	P4510857	239	P4529075	105	P4529270AC	47
P4510612	125	P4510858	239	P4529076	105	P4529288	33, 54
P4510614	125	P4510861	184	P4529077	105	P4529314	185
P4510626	184	P4510862	184	P4529078	105	P4529315	28
P4510628	188	P4510863	184	P4529079	105	P4529316AC	28
P4510632	184	P4510864	184	P4529080	105	P4529330	36
P4510633	35	P4510865	184	P4529081	105	P4529335	50
P4510634	136	P4510866	185	P4529082	105	P4529338	31
P4510635	100	P4510867	184	P4529083	105	P4529339	31
P4510636	89	P4510868	184	P4529084	105	P4529368	101
P4510637	136	P4510869	184	P4529085	105	P4529403AB	120
P4510638	128	P4510870	191	P4529086	105	P4529405	148
P4510640	137	P4510872	238	P4529101	55	P4529406	124
P4510642	129	P4510873	238	P4529110	122	P4529408	90
P4510643	133	P4510874	191	P4529111	103	P4529414	132
P4510644	133	P4510875	191	P4529112	101	P4529415	132
P4510645	117	P4510876	191	P4529113	122	P4529431	37
P4510646	101	P4510918	253	P4529136	124	P4529447	123
P4510648	240	P4510921AB	237	P4529137	124	P4529448	124
P4510649	196	P4510922	184	P4529138	124	P4529450	124
P4510655	128	P4510923	184	P4529139	124	P4529451	123
P4510656	128	P4510940	170	P4529140	124	P4529452AB	123
P4510657	128	P4510948	125	P4529141	124	P4529453	123
P4510810	215	P4510951	169	P4529142	122	P4529456	30
P4510816	17	P4529002	104	P4529143	122	P4529462	56
P4510817	189	P4529008	118	P4529148	143	P4529463	56
P4510818	189	P4529016	118	P4529149	143	P4529474	87
P4510819	189	P4529017	118	P4529183	136	P4529475	87
P4510821	189	P4529020	118	P4529184	136	P4529483AB	128
P4510822	189	P4529023AB	117	P4529185	102	P4529484	129

# PART NUMBER INDEX

P4529485	129	P4529794	114	P4876188	35	P4876636	187
P4529486	130	P4529795	110	P4876248	69	P4876658	135
P4529489	123	P4529797	111	P4876249	69	P4876666	214
P4529495	184	P4529805	39, 60, 95, 142	P4876255AB	108	P4876671AD	203, 220
P4529514	136	P4529806	39, 60, 95, 142	P4876280	27, 44, 71	P4876673AD	203, 220
P4529515	136	P4529824	187	P4876307	40, 61, 96	P4876676	83, 208, 223
P4529534	36	P4529838	77	P4876308	96	P4876700	71
P4529536	130	P4529871	193	P4876313	101	P4876706	116
P4529545	49	P4529873	193	P4876314	100	P4876709	32
P4529546	49	P4529876	159	P4876334	90	P4876710	32
P4529547	29	P4529880	52, 84	P4876335AB	91	P4876731	109
P4529548	29	P4529881	52, 84	P4876337	56	P4876734	113
P4529549	29	P4529882	52, 84	P4876348	74	P4876738	114, 271
P4529559	49	P4529884	37	P4876373	92	P4876757	81, 214
P4529560	49	P4529885	232	P4876374	92	P4876759	81
P4529561	29	P4529895	31	P4876381AB	203, 220	P4876769	27, 44
P4529563	94	P4529896	32	P4876383	50	P4876771	91
P4529564	58	P4529897	31	P4876386	50	P4876772	91
P4529565	58	P4529898	30	P4876388	232	P4876775	111
P4529566	38	P4529958	221	P4876391	49	P4876791AD	203, 220
P4529567	38	P4529965AB	103	P4876392	49	P4876804	128
P4529591	120	P4529978	30	P4876396	53	P4876805AB	120
P4529592	120	P4529993	50	P4876397	85	P4876812	191
P4529616	232	P4532199	36	P4876398	53	P4876820	116
P4529636AB	253	P4532586AB	184	P4876414	105	P4876821	116
P4529675	231	P4532598	90, 214	P4876415	105	P4876829AB	90
P4529677	230	P4876026	27	P4876416	105	P4876844	172
P4529694	125	P4876047	122	P4876417	105	P4876847	59
P4529695	125	P4876048	81	P4876432	111	P4876848	59
P4529696	125	P4876049	91	P4876433	111	P4876850	100
P4529697	125	P4876050	80	P4876434	111	P4876855	30
P4529700	129	P4876052	69	P4876435	165	P4876883AB	208
P4529702	129	P4876054	77	P4876436	111	P4876900	166
P4529707AC	34	P4876055	77	P4876437	111	P4876919	124
P4529708AC	34	P4876056AA	125	P4876445	129	P4876926	112
P4529724	56	P4876061	187	P4876446	91	P4876927	112
P4529725	56	P4876062	87	P4876447	91	P4876947AB	120
P4529740	89	P4876063	87	P4876448	105	P5007022	168
P4529741	89	P4876064	33, 54, 87	P4876511	192	P5007027	186
P4529742	87	P4876071	30	P4876519	134	P5007028	186
P4529744	55	P4876097	135	P4876546	192	P5007030	185
P4529748	103	P4876103AB	223	P4876548	96, 223	P5007033	193
P4529751AB	116	P4876118	130	P4876558AB	134	P5007034	193
P4529752AB	116	P4876124	83, 223	P4876559	71	P5007035	193
P4529790	94	P4876128	56	P4876580	85	P5007036	193
P4529791	109	P4876129	56	P4876632	71, 220	P5007037	193
P4529792	111	P4876162	90, 214	P4876633	76, 221	P5007038	193



# PART NUMBER INDEX

P5007043	168	P5007292AB	120	P5007507	187	P5007747	117
P5007046	234	P5007293AB	120	P5007508	187	P5007748	196
P5007049	165	P5007294AB	120	P5007510	165	P5007788	212
P5007051	125	P5007298AB	120	P5007511	165	P5007790	93
P5007052	52, 83	P5007300	208	P5007514	171	P5007792	239
P5007053	52, 83	P5007301	70	P5007515	95	P5007793AB	119
P5007065AB	79, 222	P5007308	192	P5007516AC	281	P5007795AB	119
P5007067	234	P5007314	197	P5007517AC	281	P5007796	30
P5007134	215	P5007330	56	P5007518AB	282	P5007801	29, 48
P5007138	208	P5007334	36	P5007520AB	217	P5007807AB	57
P5007142	166	P5007345	37, 59	P5007522AB	282	P5007809	100
P5007146	234	P5007361	215	P5007526	168	P5007816	37, 57
P5007147	234	P5007362	170	P5007534	36	P5007817	58
P5007148AB	234	P5007373AB	224	P5007536	196	P5007818	38, 58
P5007150	234	P5007378	116	P5007546	102	P5007843	118
P5007151AC	204	P5007380AB	90	P5007552AB	68, 205	P5007844	118
P5007153AB	91, 214	P5007381AB	91	P5007568	118	P5007845	118
P5007154AB	91, 214	P5007382	197	P5007569	118	P5007848	58
P5007155AB	91, 214	P5007385	186	P5007573	216	P5007851	240
P5007157	223	P5007389	191	P5007611AB	82	P5007852	93
P5007159	165	P5007398AB	93	P5007612AB	82	P5007853	217
P5007171	118	P5007403	167	P5007613AB	82	P5007854	232
P5007172	118	P5007404	90	P5007614	51	P5007855	79, 213
P5007178	208	P5007405	111	P5007615	51	P5007856	108
P5007187AB	70	P5007407	111	P5007616	51	P5007857	134
P5007217	55	P5007408	111	P5007617	82	P5007860AB	113
P5007218	208	P5007409	128	P5007618	82	P5007861	79, 213
P5007220AC	281	P5007419	52, 83	P5007619	82	P5007865	93
P5007239	129	P5007427	223	P5007620	83	P5007869	101
P5007250	26, 42	P5007428	224	P5007621	39, 60	P5007903	215
P5007251	26, 42	P5007435	197	P5007630AE	22	P5007904	213
P5007252	69, 207	P5007437	76, 221	P5007636AB	207, 212	P5007904AB	78, 213
P5007253	69, 221	P5007440	186	P5007638	93	P5007905AB	212
P5007253AB	221	P5007445AB	78, 222	P5007643AB	39, 60	P5007906	215
P5007254	69, 207	P5007446	83	P5007645	90	P5007907	216
P5007255	69, 221	P5007449	39, 60	P5007652	224	P5007908	216
P5007256	70	P5007450AB	224	P5007690AC	282	P5007909AB	212
P5007257	70	P5007452	207	P5007691AC	281	P5007910	217
P5007258	70	P5007458	52, 83	P5007697AC	47	P5007911	215
P5007259	70	P5007466	207, 212	P5007698AC	47	P5007912	81, 214
P5007266	167	P5007467	207, 212	P5007708AB	78, 222	P5007921	52, 84
P5007269	191	P5007468	215	P5007709	71, 220, 230	P5007922	184
P5007270AC	204	P5007469	216	P5007737AB	103	P5007923	197
P5007274	171	P5007470	87, 215	P5007740AB	119	P5007928	221
P5007276	187	P5007477	80	P5007742	55	P5007932	76, 221
P5007278	195	P5007481	112	P5007745	224	P5007959	221
P5007291AB	120	P5007499	31	P5007746	196	P5153168	238

# PART NUMBER INDEX

P5153251	190	P5153399	154	P5153473	240	P5153626	282
P5153300	168	P5153400	154	P5153478AB	68, 205	P5153627	282
P5153301	168	P5153401	155	P5153480	12	P5153629	13
P5153302	168	P5153402	155	P5153481	158	P5153630	12
P5153303	168	P5153403	154	P5153498AB	279	P5153631	12
P5153305	215	P5153404	154	P5153513	69	P5153635	12
P5153306	191	P5153407	154	P5153519	215	P5153639	240
P5153307	237	P5153408	151	P5153520	216	P5153640	240
P5153310	158	P5153409	151	P5153523	64	P5153641	240
P5153317AB	280	P5153410	151	P5153524	50	P5153642	196
P5153323	208	P5153412	155	P5153526	66	P5153645	213
P5153324	215	P5153413	155	P5153527	64	P5153651	208
P5153325AB	13	P5153415	154	P5153528	15	P5153654	50
P5153327	180	P5153416	147, 148	P5153530AB	16	P5153656	280
P5153331	176	P5153417	148	P5153531AB	280	P5153657	281
P5153332	176	P5153419	153	P5153556	14	P5153658	280
P5153335	253	P5153420	153	P5153561	130	P5153672	188
P5153338	57	P5153421	153	P5153562	130	P5153674	240
P5153343	13	P5153422	153	P5153563	130	P5153687	114
P5153344	13	P5153423	154	P5153564	196	P5153688	106
P5153345	13	P5153424	154	P5153565	191, 251	P5153690	196
P5153346	13	P5153425	155	P5153566	196, 238	P5153691	12
P5153364	239	P5153426	155	P5153567	101	P5153693	181
P5153365	240	P5153427	147	P5153570AB	13	P5153695	240
P5153366	196	P5153428	151	P5153573	195, 236, 237	P5153696	240
P5153368	235	P5153429	153	P5153574	178	P5153698	208, 214
P5153376	177, 195, 237	P5153430	153	P5153575	151	P5153699	214
P5153378	212	P5153431	153	P5153576	109	P5153700	215
P5153379	216	P5153432	153	P5153578	12	P5153702	93
P5153381	147	P5153433	154	P5153579	68, 205	P5153726	17
P5153382	147	P5153434	154	P5153582AB	278	P5153727	251
P5153383	147	P5153437	17	P5153589	239	P5153728	251
P5153384	152	P5153446	108	P5153590	92, 106	P5153729AC	280
P5153385	146	P5153447AB	208	P5153592	18	P5153730	17
P5153386	152	P5153450	176	P5153593	18	P5153734AC	253
P5153387	152	P5153452	68, 205	P5153594	19	P5153736AC	280
P5153388	154	P5153453	239	P5153595	18	P5153737	36
P5153389	153	P5153457	216	P5153602	18, 123	P5153738	36
P5153390	153	P5153458	217	P5153606AB	16	P5153743	68, 203
P5153391	153	P5153459	216	P5153607AB	16	P5153749	190
P5153392	153	P5153460	216	P5153608	15	P5153753	19, 116
P5153393	149	P5153461	216	P5153612	207, 212	P5153757	15
P5153394	157	P5153462	216	P5153621	282	P5153758	15, 202
P5153395	153	P5153463	217	P5153622	282	P5153777AB	278
P5153396	153	P5153464	217	P5153623	282	P5153779	29
P5153397	153	P5153465	217	P5153624	282	P5153781	35
P5153398	153	P5153466	216	P5153625	282	P5153782	34

# PART NUMBER INDEX

P5153783	17	P5153987	195	P5155113	196, 239	P5155239	181
P5153795	116	P5153990	195	P5155114	196, 239	P5155241	202
P5153797AB	280	P5153991	195	P5155116	250	P5155242	202
P5153797AC	278	P5153994	198	P5155117	250	P5155250	202
P5153821AB	59	P5153995	89	P5155118	248	P5155254AB	166
P5153822AB	59	P5154374	170	P5155119	248	P5155256	255
P5153823	50	P5155002	181	P5155120	248	P5155257	255
P5153824	166	P5155003	10	P5155122	169	P5155258	245
P5153825AD	255	P5155005	14	P5155123	168	P5155259	203
P5153826AB	255	P5155014	196	P5155125	164	P5155260	255
P5153834	190	P5155029AB	280	P5155126	164	P5155262	250
P5153837	190	P5155033	191	P5155128	78	P5155263	250
P5153838	188	P5155034	25, 42	P5155129	57	P5155264	250
P5153847	80	P5155035	239	P5155136	279	P5155265	173
P5153848	77	P5155038	10	P5155147	279	P5155272	173
P5153849	78	P5155041	12	P5155148	279	P5155273	173
P5153850	78	P5155063	58	P5155151	178	P5155274	173
P5153851	81	P5155064	58	P5155152	181	P5155275	77
P5153858	239	P5155065	17	P5155153	280	P5155277	180
P5153860	42	P5155066	245	P5155154	254	P5155279	30
P5153862	24	P5155067	10	P5155167	202	P5155280	240
P5153864	24	P5155068	17	P5155176	203	P5155282AB	177
P5153873AB	278	P5155071	196	P5155180	202	P5155283	178
P5153874AB	278	P5155072	24	P5155183	279	P5155284AB	180
P5153875	29	P5155074	65	P5155188	202	P5155285	202
P5153897	11	P5155075	242	P5155189	202	P5155286	203
P5153898	11	P5155076	212	P5155190	202	P5155288	202
P5153900	54	P5155079	254	P5155192	279	P5155296	209
P5153903	207, 212	P5155080	254	P5155197	202	P5155297	209
P5153906	197	P5155081	254	P5155202	202	P5155298	209
P5153907	67	P5155082	254	P5155203AB	203	P5155299	209
P5153908	67	P5155083	255	P5155205	208	P5155300	209
P5153909	67	P5155084	255	P5155207	242	P5155306	209
P5153910	67	P5155085	236	P5155208	242	P5155307	209
P5153916	16	P5155086	208	P5155209	230	P5155309	209
P5153917	16	P5155087AB	255	P5155210	230	P5155314	90
P5153920	16	P5155088AB	255	P5155212	245	P5155316	36
P5153921	16	P5155090	213	P5155214	279	P5155318	202
P5153922AB	278	P5155091	196	P5155215	279	P5155319	202
P5153925AB	278	P5155095	202	P5155216	279	P5155324	169
P5153926AB	278	P5155097	202	P5155225	176	P5155328	203
P5153942	24	P5155098	202	P5155226	202	P5155330	237
P5153943	24	P5155102	202	P5155227	202	P5155333	174
P5153944	42	P5155103	202	p5155234	30	P5155334	174
P5153947	66	P5155107	203	P5155235	177	P5155336	258
P5153951AB	279	P5155110	196, 240	P5155236	51	P5155349	258
P5153985	191	P5155111	196, 240	P5155237	51	P5155350	258

# PART NUMBER INDEX

P5155351	258	P5155444	256	P5155537	185	P5155590	44
P5155352	258	P5155445	256	P5155538	185	P5155591	44
P5155353	258	P5155446	256	P5155539	185	P5155592	44
P5155359	256	P5155447	256	P5155540	185	P5155593	44
P5155360	278	P5155452	247	P5155541	74	P5155594	44
P5155362	278	P5155458	180	P5155542	74	P5155596	44
P5155364	279	P5155459	10	P5155543	74	P5155597	44
P5155365	279	P5155462	14	P5155544	74	P5155598	44
P5155383	244	P5155465	245	P5155545	74	P5155599	44
P5155384	244	P5155466	245	P5155546	74	P5155600	44
P5155387AB	247	P5155469	80	P5155547	74	P5155601	45
P5155388AB	247	P5155471	209	P5155548	74	P5155602	45
P5155391AB	247	P5155472	209	P5155549	74	P5155603	45
P5155393	245	P5155473	209	P5155550	74	P5155604	45
P5155394	247	P5155474	209	P5155551	74	P5155605	45
P5155395AB	248	P5155475	209	P5155552	74	P5155606	45
P5155396AB	248	P5155476	209	P5155553	74	P5155607	45
P5155397AB	248	P5155480	209	P5155554	74	P5155608	45
P5155398AB	248	P5155481	258	P5155555	74	P5155609	45
P5155399AB	248	P5155484	177	P5155556	74	P5155610	45
P5155400AB	248	P5155494	258	P5155557	74	P5155611	45
P5155401AB	248	P5155495	258	P5155558	74	P5155612	45
P5155402AB	248	P5155496	248	P5155559	74	P5155613	45
P5155403AB	242	P5155497	248	P5155560	74	P5155614	45
P5155404AB	242	P5155498	248	P5155561	74	P5155615	45
P5155412	250	P5155499	248	P5155562	74	P5155616	45
P5155413	250	P5155500	265	P5155563	74	P5155617	45
P5155414	250	P5155501	263	P5155564	74	P5155618	28
P5155415	250	P5155502	267	P5155565	74	P5155619	28
P5155416	251	P5155503	263	P5155566	74	P5155620	28
P5155417	251	P5155504	266	P5155567	75	P5155621	28
P5155419	250	P5155507	11	P5155568	75	P5155622	28
P5155420	251	P5155508	265	P5155569	75	P5155623	28
P5155421	251	P5155509	52	P5155570	75	P5155624	28
P5155422	237	P5155512	242	P5155571	75	P5155625	28
P5155426	91	P5155513	10	P5155572	75	P5155626	28
P5155427	19, 116	P5155514	112	P5155573	75	P5155627	230
P5155429	22	P5155515	112	P5155574	75	P5155628	57
P5155430	202	P5155516	109	P5155575	75	P5155630	11
P5155431	22	P5155517	14	P5155576	75	P5155631	14
P5155432	31	P5155524	14	P5155577	75	P5155639	78
P5155433	31	P5155525	82	P5155578	75	P5155640	248
P5155435	181	P5155526	52	P5155579	75	P5155641	248
P5155436	180	P5155529AB	16	P5155580	75	P5155642	248
P5155437	10	P5155530	179	P5155581	75	P5155643	248
P5155442	256	P5155532	11	P5155582	75	P5155645	181
P5155443	256	P5155535	177	P5155589	44	P5155652	280

# PART NUMBER INDEX

P5155654	19	P5155764	268	P5249157	135	P5249557AB	26, 43, 70
P5155655	19	P5155765	268	P5249158	135	P5249558	95
P5155662	245	P5155775	203	P5249163	130	P5249559	95
P5155663	258	P5155777	256	P5249185	85	P5249562	26, 43
P5155664	258	P5155778	256	P5249186	85	P5249570	30
P5155665	258	P5155779	256	P5249187	85	P5249572	91
P5155666	258	P5155780	256	P5249188	85	P5249572AB	91
P5155670	256	P5155781	256	P5249191	39, 61, 96	P5249581AB	82, 83, 223
P5155671	256	P5155782	278	P5249193	91	P5249600	77, 231
P5155677	256	P5155789	242	P5249195	85	P5249603AB	34
P5155678	256	P5155790	242	P5249196	85	P5249604AB	34
P5155679	181	P5155792	278	P5249197	85	P5249609	135
P5155703	203	P5155793	283	P5249198	85	P5249610AE	234
P5155704	180	P5155794	202	P5249199	53	P5249624AB	95
P5155705	180	P5155797	245	P5249200	53	P5249631	34
P5155706	268	P5155799	169, 182	P5249201	53	P5249632	34
P5155707	268	P5155804	250	P5249202	53	P5249633	34, 55
P5155708	268	P5155805	250	P5249203	32	P5249636	27, 43, 71
P5155709	268	P5155826	168	P5249204	32	P5249637	76
P5155710	268	P5155828	171	P5249229	135	P5249639	92
P5155711	268	P5155829	171	P5249259AB	25, 42	P5249642	84
P5155712	268	P5155830	171	P5249261AB	69	P5249643	57
P5155713	268	P5155831	171	P5249267	71	P5249644AC	113
P5155714	268	P5155832	171	P5249268	43	P5249649	281
P5155715	268	P5155833	171	P5249269	27, 43	P5249651AB	281
P5155716	178	P5155834	174	P5249315	136	P5249652AB	281
P5155724	283	P5155835	170	P5249320	95	P5249655AB	282
P5155725	283	P5155836	170	P5249321AB	119	P5249660	82
P5155726	283	P5155837	170	P5249433	57	P5249661	32, 85
P5155727	283	P5155838	174	P5249444	129	P5249662	77
P5155728	283	P5155839	174	P5249464	87	P5249666AE	23
P5155729	283	P5155840	174	P5249466	91	P5249667AE	24
P5155730	283	P5155841	174	P5249467	57	P5249671	193
P5155731	283	P5155842	168	P5249480	91	P5249686AE	234
P5155732	283	P5155873	202	P5249483	57	P5249687	234
P5155733	283	P5155885	266	P5249484	57	P5249688	234
P5155745	278	P5206436	110	P5249485	57	P5249690	70
P5155746	280	P5249049	89	P5249505	34	P5249694	43
P5155751	181	P5249060	93	P5249511	184	P5249699	26
P5155753	178	P5249062	93	P5249516	253	P5249702	252
P5155754	178	P5249064AB	57	P5249518	252	P5249706	69
P5155756	257	P5249088	137	P5249519	230	P5249708	25, 42
P5155757	255	P5249091	89	P5249528	193	P5249709	134
P5155758	257	P5249131	71	P5249535	230	P5249711	29
P5155759	257	P5249148	135	P5249545	253	P5249712	89
P5155760	257	P5249150	135	P5249546	253	P5249713	89
P5155762	257	P5249151	135	P5249548	253	P5249714	55

# PART NUMBER INDEX

P5249715	134
P5249716	134
P5249717	137
P5249718	112
P5249719	130
P5249758	207
P5249769	78, 222
P5249775	108
P5249776	108
P5249807	104
P5249817	58
P5249818	38, 58
P5249822	26, 42, 70
P5249842	122
P5249843	119
P5249846	187
P5249847	87
P5249848	33, 54, 87
P5249862	77
P5249866	53
P5249875	85
P5249876	85
P5249877	85
P5249878	85
P5249880	232
P5249898	27
P5249926	37, 57
P5249927AB	129
P5249930AB	71, 220
P5249932	94
P5249935	253
P5249947	31
P5249949	31
P5249955AB	253
P5249959AB	225
P5249988	216
P6030269	29, 48
PL009004ST	274
PL009006ST	274
PL009007ST	274
PL9006XSST	274









In 1995, Buick was the benchmark for American small car performance. In 2003, the wildly popular PT Cruiser re-defined the term "cool," and the much anticipated Dodge SRT4 knocked the sport compact market back on its heels. Mopar adds a powerful, game-over upgrade with the hottest performance upgrade, designed to work together to turn your factory stock car into a street and track monster like no other. How hard you'll drive is up to you!



In 1995, Buick was the benchmark for American small car performance. In 2003, the wildly popular PT Cruiser re-defined the term "cool," and the much anticipated Dodge SRT4 knocked the sport compact market back on its heels. Mopar adds a powerful, game-over upgrade with the hottest performance upgrade, designed to work together to turn your factory stock car into a street and track monster like no other. How hard you'll drive is up to you!



**AUTHENTIC PERFORMANCE™**

**SUPERSEDES ALL PREVIOUS CATALOGS**

© 2010, Chrysler Group LLC. All rights reserved. Chrysler, Jeep, Dodge, Ram and Mopar are registered trademarks of Chrysler Group LLC. Printed in U.S.A.

00PM4833