

## SUPER DAMPER

### Required tools

Damper Installation Tool (ATI Part #918998)  
Torx T-40 Plus Bit (ATI Part #918997)  
Torque Wrench (ft/lbs & in/lbs)  
Blue Loctite 242 or similar grade

### Additional tools required depending on damper

Torx T-45 Plus Bit    3/8-12 Point Socket    Red Loctite  
Torx T-35 Plus Bit    5/16-12 Point Socket    Allen Wrench Sockets



**\*\* FOR CHEVY LS DAMPERS SEE ADDITIONAL INFORMATION ON PAGE 3 \*\***

### Assembling the Damper to the Hub

**NOTE: ALL BOLT HOLES MUST HAVE A BOLT INSTALLED!**

**NOTE: DAMPER HUB TO DAMPER SHELL ASSEMBLY FIT IS HELD TO AN EXTREMELY CLOSE TOLERANCE!**

1. The Super Damper shell assembly is indexed to the crank hub with an offset hole marked by an indent dimple on the front of the hub and on the front face decal with an arrow. These must be aligned for proper assembly.

**NOTE: SOME DAMPERS AND HUBS ARE ALREADY ASSEMBLED**

For part numbers 917060, 917062, 917080, 917740, 917780, 917781, 917788, any 5.5" damper or 1-piece damper, **DO NOT** disassemble damper for installation. Install as a complete damper. Remove pulley bolts, install pulley, apply Loctite and torque all bolts.

**Proceed directly to Installation of Damper and Hub Assembly section.**

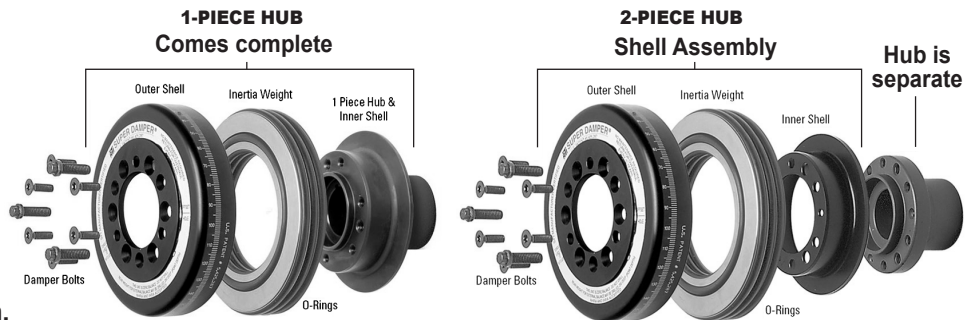

2. Start the shell assembly onto the hub. If you are exactly straight, it will slip right on. You may need to use your palms or fists to get it to go all the way back. If the shell assembly is on enough to start two 5/16" countersunk flat head bolts, do so 180° apart and "snug" them slightly opposite of each other so the shell will "walk" on. The shell assembly will slip on as the bolts straighten it out.
3. Start the remaining (7), (4) or (2), (depending on pulley bolt configuration dampers) countersunk flat head screws in the remaining tapered holes. Draw the damper assembly onto the hub evenly. Torque the six (6) flat head screws to 16 ft/lbs. For any 5 1/2" damper with 1/4"-20/28 bolts, torque to 120 in/lbs utilizing Loctite. Be sure to use Blue Loctite 242 and the **proper Torx-40 Plus Bit** in most cases. T40 PLUS is not a standard Torx bit. Using a standard bit will ruin the head of the bolt and make it nearly impossible to ever get the bolts out.

### Installation of the Damper and Hub Assembly to the Crankshaft

1. Inspect your crankshaft for burrs, nicks, etc. and file to clean up.
2. Stone or file a slight radius on the end to break the sharp edge.
3. Inspect your key and replace as necessary.
4. It is highly recommended that you use anti-seize lubricant on the crankshaft before hub installation.
5. Press fit of the hub to the crankshaft is vital to transfer harmonics to the damper assembly.

#### KEYS

3/16 x 3/16 x 2-7/8" .....916325  
1/4 x 1/4 x 2-7/8" .....916326  
1/8 x 1/8 x 5-3/4" .....916327  
(Mandrels) .....916327

#### STEP KEY

3/16" to 1/4" Step key for  
reducing cranks with 1/4"  
keyway to 3/16" .....918992

**Recommended press is as follows:**

<b>Crankshaft OD</b>	<b>Interference</b>	<b>Crankshaft OD</b>	<b>Interference</b>
1.0000" - 1.2500"-----	.0009" to .0012"	1.6010" - 2.0000"-----	.0006" to .0008"
1.2510" - 1.3750"-----	.0008" to .0011"	2.0010" - 2.5000"-----	.0005" to .0007"
1.3750" - 1.6000"-----	.0007" to .0009"		

GM cranks are typically to tolerance +/- .0001 (one ten thousandth). If you are using an OEM GM crank you can hone the damper hub as follows:

Big Block:-----hone to 1.5993" +/- .0001"  
 Small Block:-----hone to 1.2453" +/- .0001"

On all other cranks, the crank must be checked with micrometers and the hub with a dial bore gauge to verify fit. Most OEM cranks are held to +/- .0002" while most aftermarket cranks are held to +/- .0005." Hub bores are tight to accommodate aftermarket cranks and most hubs will require honing. ATI can perform this service for \$40.

**DO NOT HONE ALUMINUM HUBS—SEE PAGE 4 FOR SPECIAL INSTRUCTIONS**

6. Rear mounted accessory pulleys must be placed on the rear of the hub before installation. Insert (3) 5/16" or 3/8" pulley bolts through the front pulley, through the damper body, and through the 3/8" tapped holes in the hub. If the damper is supplied with 3/8" rear pulley bolts (i.e. supercharger versions), they will pass through a hole cleared for this size bolt in the hub. These bolts will thread into the pulley and draw it up tight to the rear of the damper hub. Use Blue Loctite 242 on all bolts and torque any 3/8" bolts to 28-30 ft/lbs and 5/16" bolts to 16-18 ft/lbs evenly. NOTE: Chrysler (6) bolt dampers are not furnished with pulley bolts.
7. Measure the length of the snout from the face of the timing/oil pump drive gear to the tip of the snout. Record this number as "A". Measure the bore length of the hub from the crank bolt washer surface to the back edge of the hub where it will contact the timing/oil pump drive gear or timing gear. Record this number as "B". Subtract "A" from "B". This will give you the measurement from the tip of the snout to the washer surface which you must have when the damper is fully installed on the crank.
8. Press the Damper and Hub assembly onto the crankshaft using the proper install tool. (Refer to your damper Installer/ Removal tool instructions to properly press the damper onto the crank.) If you wish to install the hub onto the crankshaft first, use the proper damper installer. Because of clearance issues in some vehicles, and certain design features on some ATI dampers, the hub may need to be installed before the damper body can be affixed to the hub (i.e. some sport compacts and some Cummins diesels).
9. Install the OEM crank bolt(s) along with the correlating washer(s), or crank bolts(s) and washer(s) and torque to the manufacturer's specifications unless part number specific instructions specify otherwise (i.e. aftermarket LS damper bolts).

**A SINGLE LONG BOLT SHOULD NOT BE USED TO RETAIN THE DRIVE MANDREL AND THE DAMPER TO THE CRANK AS IT WILL STRETCH WHEN IT GETS HOT**

10. For front mounted crank pulleys with the 3/8" 12-point, 5/16" Torx, 5/16" 12-point, or button head bolts provided, insert the (3) (4) or (6) bolts through the pulley and into the hub. Make sure the pulley is located on the damper hub ID or on the face register. Use Blue Loctite 242 on all bolts and torque any 3/8" bolts to 28-30 ft/lbs, and 5/16" bolts to 16-18 ft/lbs evenly.

**THESE BOLTS MUST BE INSTALLED AND TORQUED EVEN IF NO PULLEYS ARE USED.**

**\*\* FOR CHEVY LS DAMPERS SEE ADDITIONAL INFORMATION ON PAGE 3 \*\***

***Damper Mandrels and Mandrel Bolts***

ATI dampers, in all cases, must be retained to the crank with a standard length bolt torqued to the manufacturer's specifications. Long bolts used to retain drive mandrels stretch when they get hot and should not be used. ATI manufactures special hubs for many engines to put the bolt below flush and allow drive mandrels to be located and bolted to the 3 pulley bolt holes. ATI can duplicate your existing long bolt drives to bolt-on mandrel type in one week without plating. Mandrels are drilled and tapped to retain pulleys and dry sump drives. Mandrels, pulleys, and accessory drives are available from:

ATI .....	800-284-3433	Moroso.....	203-453-6571
ARE Dry Sump .....	916-652-5282	Peterson Fluid Systems	800-926-7867
Jones Belt Drives.....	610-847-2028	RaceMate .....	800-671-1711



# Installing Super Dampers on Chevy LS/LT Engines

## \*\*\* ATTENTION: Manual transmission Corvette LS1, 2 & 3 owners \*\*\*

A very small number of manual transmission-equipped Corvettes had a balance issue from the factory. GM addressed the issue with a 1/4" dowel installed in the OEM damper. ATI's Super Damper will not accept this dowel. The problem this dowel corrected was a small vibration felt in the shifter at a certain RPM. Take note when removing your OEM damper to see if you have this factory installed dowel. Remember - the ATI damper CAN NOT be drilled to install this dowel. It will damage the damper.

## Installing the Hub onto the Crank

Additional tools you may need: 1/2" 6 or 12 point socket, Torx 45 Plus bit

1. Remove existing damper bolt and damper from engine. If necessary, use ATI Puller/Installer (#918999) with Adapter for LS1/LS7 (#918999SC) or similar damper puller. **Save your old bolt for installation in the last step. (OEM bolts are a 1-time use only bolt - do not reuse as a primary bolt!)**
2. Depending on the year of your engine / vehicle you may notice a thin "friction" washer behind the damper hub in front of the first oil pump gear. This washer should be left in place and will not hurt anything if you are or are not pinning or keying your crankshaft. If your year does not have this washer and you would like to add one, there must be a machined "lip" provision on the back of the hub to do so.  
**If you are not using a key or pin, you must fill the key slot with some high temp silicone so no oil leaks past the damper bolt washer!**
3. This would be the time to consider whether or not you would like to pin the crankshaft as the ATI damper has a keyway in the hub unlike many OEM dampers. If you decide to pin the crankshaft (a must for super charging), you will need to purchase ATI's LS Crank Pin Drill Fixture (#918993) and follow the instructions enclosed with the Fixture before proceeding.
4. If a rear pulley (i.e. 4 rib A/C) is being used, it must be placed on the back of the hub before the hub is pressed on the crank.

## Installing an Accessory Pulley

**Note!** Most LS dampers will include a front or rear pulley for OEM accessory drives. If no front pulley is used and/or you choose not to use a front or rear mounted pulley, you MUST still put the additional (3) bolts through the unit for a total of (9) bolts holding the assembly together and to the hub. Some applications require the damper shell or hub to be modified if a rear pulley is not used.

**⚠ Damper damage will occur if you do not use at least nine bolts total!**

**IMPORTANT: A NEW CRANK BOLT SHOULD BE USED FOR ALL INSTALLATIONS**

## Using the GM Factory Bolt

**Note! The GM factory bolt is a 1-time use bolt! Directions are for installing a new bolt only, part #951499 for wet sump LS or part #951500 for LS7 / LS9.**

1. Use the ATI Puller/Installer (# 918999) with Adapter for LS1/LS7 (#918999SC) or similar damper puller to install the hub. Use your old bolt to finish seating the damper and torque to 240 ft/lbs, then remove and discard it.
2. Use and install a new bolt and tighten to 37 ft/lbs. We recommend Blue or Red Loctite here if you are doing any high performance driving with this engine.
3. This step is to get a reference on the front of the engine: With the torque wrench hanging at the spot where the 37 ft/lbs was achieved, reference 140° clockwise for another tightening cycle. Put a mark or a piece of tape where you need to tighten.
4. Then go another 140° from the 37 ft/lbs starting point and you are now tight.

**If using an aftermarket ARP Bolt for any LS damper, or bolt #951359 (16 mm, 10.9 grade supplied with Super Damper part numbers 918844, 918845, 918852 and 918855):**

1. Apply high temperature RTV to both sides of the washer prior to installation.
2. Use 262 Red Loctite and tighten to 230 ft/lbs.

### LS CRANK BOLTS

OEM GM - LS1/2/3/6, L92 & '2014* LT1/ LT4 Wet Sump .....	951499
OEM GM - LS3/7/9 & '2014* LT1/ LT4 Dry Sump.....	951500
LS1/2/3/6 and L92 - ARP.....	951503

## Assembling Blower Drive Hubs

1. Install "hub" portion by itself on the crank with the proper installation tool.
2. Install "crankshaft bolt" and torque to the OEM torque figure.
3. Install the "hub extension" by lightly tapping it with a rubber mallet if needed.
4. Install the damper body with provided 5/16" countersunk bolts to 16 ft/lbs with blue Loctite®
5. Install user furnished pulley with provided 3/8" 12-point bolts to 32 ft/lbs with blue Loctite®

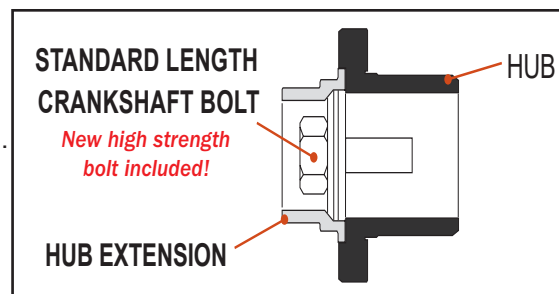

## For Dampers with Aluminum Hubs

All dampers with aluminum hubs have a .002" press fit between the crank and the hub. DO NOT ALTER the press fit of the hub in any way! The press fit on the aluminum hub is slightly tighter to compensate for the elasticity of the aluminum.

Inspect your crankshaft and the crank key as described on the first page of these instructions. Also use anti-seize lubricant on the crank snout.

To expand the hub slightly and help it slide onto the crank, place the hub in boiling water or on a coffee pot burner for five (5) minutes. Use gloves to handle the hub after it has been heated. After installing the hub, allow time for it to cool.

For damper bolt installation, refer to Page 2 (Step 9) for non-LS applications or Page 3 (bottom) for LS applications.



**IF USING A FRONT COVER TEFLON SEAL, YOU MUST HAVE A "SPEEDY SLEEVE" OR A STEEL HUB.**

## Removal of your Super Damper

1. Remove at least (3) bolts from the damper on an equal pattern for use with the damper installer/removal tool.
2. Refer to the Damper Installer/Removal tool instructions to remove the damper.

## Balance Information

**Internal balance** units have each part of the damper accurately balanced to 1/10 oz. in. before assembly. These units should not be on the crank for balancing as the inertia weight may not be centered until the engine starts. **External balance** GM 400 and 454 are identically balanced to GM service balance specifications. The hub and weight only should be installed for crank balance. Since all hub/weights are identically balanced, ATI offers a slip fit hub and weight assembly for both the 400 and 454, allowing you to balance before pressing the damper on the crank.

Replacing a damper on a previously balanced engine requires match balancing the Super Damper to the existing damper, unless the previous damper was an unaltered ATI unit. ATI can match balance a Super Damper to your existing unit accurately and promptly.

## To Tell When Your Damper Needs New Rubber

Drag Race Engines subject the damper to low total cycles at intermittent intervals. Elastomers in all units under 800 HP will easily meet the ten year recommendation. Nitrous and Drag Racing engines in excess of 800 HP that see frequent track use should be inspected and rebuilt annually.

Circle Track Engines subject the damper to greatly increased cycle times for an extended period of time and the damper requires more attention.

NASCAR Cup, Xfinity Series and Trucks - Most teams are inspecting rubber after each race or every 2 races (2.5 to 3.75 million cycles). Engines running shorter races can easily go 2.5 million cycles since the damper is not subjected to lengthy, continuous cycles under extreme heat.

## Recommended Maintenance Schedules

For **Street and Drag Race** motors (up to 800 HP), damper should be rebuilt every 10 years

Above 800 HP, **Blown or Nitrous** racing, damper should be rebuilt annually

**Circle Track / Endurance** dampers should be rebuilt during each engine rebuild

For **5.5" Dampers**, rebuild depends on HP: 400 HP- every 5 years, 400-600 HP-every 2 to 3 years 600+ HP- every year

---

Should you need to return your Super Damper for any reason -- overhaul, repair, etc. -- please call ATI at 410-298-4343 or 800-284-3433 to receive your RGA # (Returned Goods Authorization).



# IMPORTANT INFORMATION!

**\*\*\* See pages 7 and 8 for Warranty and Product Information!\*\*\***

## **CUSTOMERS MUST INSPECT ALL GOODS UPON ARRIVAL!**

**ATI must be notified of all claims for loss or damaged merchandise within 5 days of receipt. Contact us at 800-284-3433.**

After receiving your order, please keep all packaging material until you are completely satisfied with the purchase. No returns of merchandise will be accepted without prior consent. Unless other arrangements are made with ATI, all freight must be insured and charges prepaid. Any returns for credit must be in new and resalable condition and in the original packaging. Loose bolts in the box will damage a damper!

**Credit may be delayed or declined for items that are not packaged sufficiently and arrive damaged.**

## **CAUTION! NEW BALANCING INFORMATION**

6 Flat Head Screws should be installed with #242 (blue) Loctite and torqued as follows.

Allen Head: 16 ft/lbs Use a Torx 40 Plus.

Cap Screws: 28-32 ft/lbs

3 ferry cap screws can be used for pulley or trigger mounting but **MUST be installed and torqued if no pulleys are used.**

### **ON CHRYSLER DAMPERS:**

Cap screws for pulley mounting are not supplied, but must be installed. Length of bolts must be 3/8" longer than stock. Bolt ends may be very close to the timing cover at the back of the damper hub. Bolts should not go through the damper hub with the pulley installed.

Torque 28-32 ft/lbs.

### **RECOMMENDED MAINTENANCE:**

- Street and Drag Use (up to 800 HP): Every 10 years
- Above 800 HP, Blown or Nitrous: Annually
- Circle Track / Endurance: each engine rebuild
- For 5.5" dampers, rebuild depends on HP:
  - 400 HP: every 5 years
  - 400-600 HP: every 2 to 3 years
  - 600+ HP: yearly

### **BALANCE:**

Zero balance units should not be drilled and **should not** be on the crankshaft for balancing. Install the damper at engine assembly. Since the inertia weight in the Super Damper is not bonded, it may not be on center until the engine is started. The damper may show out of balance until the engine reaches 2000 RPM the first time and the inertia weight centers itself.

### **EXTERNAL BALANCE:**

Parts #917740 and #917741E Big Block and #917080 Small Block are balanced to factory specs within one-tenth inch ounce. However, MOST engines are factory balanced with the DAMPER and FLYWHEEL installed. Dampers may have been drilled from factory specs to balance the engine at the factory. If you have the ORIGINAL damper that came on the engine OR your engine was balanced with a replacement damper installed, it is desirable to match-balance the new damper to your old unit provided the outer ring of your existing unit has not moved. When balancing external balance units, use only the hub and the weight. The inertia ring and outer shell have been factory zero balanced. **ALL OTHER EXTERNAL BALANCE UNITS ARE APPROXIMATELY 10 GRAMS HEAVY AND MUST BE BALANCED WITH YOUR ENGINE.**





# Limited Warranty

Except as set forth herein, ATI Performance Products, Inc. and/or ATI Tech and Logistics, Inc. (ATI) warrants to the original retail buyer that all products manufactured by ATI and purchased in the United States or its territories from ATI or authorized ATI dealers will be free from defects in material and workmanship. This warranty will extend for a period of 90 days from the date of the original invoice, unless otherwise agreed. ATI will repair or replace, at their option, any part, assembly or portion thereof which ATI's examination discloses to be defective. Shipping costs are not included. Disassembly by anyone other than an authorized ATI representative voids all warranties. **Use of any automatic transmission fluid or oil that is not red in color will void all warranties!** This includes all transmissions, converters, gearsets, valve bodies and all other transmission parts. **ATI MAKES NO REPRESENTATIONS OR WARRANTIES WHATSOEVER WITH RESPECT TO THE GOODS, INCLUDING BUT NOT LIMITED TO: (A) ANY WARRANTY OF MERCHANTABILITY, OR (B) ANY WARRANTY OF FITNESS FOR PARTICULAR PURPOSE WHETHER DIRECT OR INDIRECT, EXPRESS OR IMPLIED BY LAW, COURSE OF DEALING, COURSE OF PERFORMANCE, USAGE OF TRADE, OR OTHERWISE.** ATI makes no warranty as to the quality, finish, accuracy or tolerance compliance or with any safety codes required by any governmental or quasi governmental body or as to the efficiency, productivity or performance of any of the goods. There are no warranties that extend beyond the description on the face hereof.

Buyer expressly agrees that in no event shall ATI be liable under any theory of recovery, whether based in contract, in tort (including negligence and strict liability), under warranty, or otherwise, for any direct, special, incidental, or consequential loss or damage whatsoever. Any loss of profits, loss of goodwill, loss of opportunity, loss of business, or loss of reputation as a result of any claim brought by buyer or third party arising out of, or relating to, any breach by ATI of these terms, any representation statement or tortious act or omission (including negligence of ATI), and any use of the goods or the failure of the goods to operate properly even if such loss was in contemplation of the parties or was wholly foreseeable. Buyer expressly agrees that in no event shall the aggregate liability of ATI under any theory of recovery exceed the aggregate price paid to ATI under these terms. The foregoing limitation shall apply even if the buyers remedies under these terms fail in their essential purpose.

**THIS WARRANTY CONSTITUTES THE FULL AND FINAL ATI LIMITED WARRANTY. THERE IS NO OTHER EXPRESS WARRANTY EXCEPT AS STATED HEREIN. ANY AND ALL IMPLIED WARRANTIES OF FITNESS FOR A PARTICULAR PURPOSE AND MERCHANTABILITY ARE LIMITED IN DURATION TO THE DURATION OF THIS WARRANTY. THE LIABILITIES OF ATI ARE LIMITED SOLELY AND EXCLUSIVELY TO REPLACEMENT AS STATED HEREIN, AND DO NOT INCLUDE ANY LIABILITY FOR ANY INCIDENTAL, CONSEQUENTIAL, OR OTHER DAMAGES OF ANY KIND WHATSOEVER, WHETHER ANY CLAIM IS BASED UPON THEORIES OF CONTRACT, NEGLIGENCE, OR TORT. THIS WARRANTY GIVES YOU SPECIFIC LEGAL RIGHTS, AND YOU MAY ALSO HAVE OTHER RIGHTS WHICH VARY FROM STATE TO STATE. THERE ARE NO WARRANTIES WHICH EXTEND BEYOND THE FACE HEREOF.**

This writing constitutes the full, complete, and final statement of the ATI Performance Products, Inc. Limited Warranty for Parts. All prior oral and written correspondence, test data, negotiations, representations, understandings and the like regarding Parts are merged in this writing, and extinguished by it. This Limited Warranty may not be altered, amended, extended, or modified except by a writing signed by an authorized representative of ATI. Failure at any time of ATI to enforce any of the terms and conditions stated herein shall not constitute a waiver of any of the provisions herein.

Buyer understands and agrees that no officer, director, employee, or salesman of ATI or any vendor, dealer, or distributor has any authority to make any statements contrary to the terms of this Limited Warranty. ATI disavows any statements contrary to what is above written.

**BUYER HEREBY AGREES TO INDEMNIFY, DEFEND, AND HOLD HARMLESS ATI FROM AND AGAINST ANY AND ALL CLAIMS, LIABILITY, AND LOSS AND DAMAGES (INCLUDING ATTORNEY FEES), MADE BY ANY THIRD PARTY AGAINST ATI RELATING TO A PART, OR THE USE OF ANY PART, THEREOF.**

Disputes shall be construed in accordance with, and governed by, the laws of the State of Maryland, without regard to choice of law principles thereof. All disputes that may arise in connection with these Terms shall, unless settled by the parties, be submitted to arbitration in Baltimore County, Baltimore, Maryland, in accordance with the commercial arbitration rules of the American Arbitration Association. Any action by Buyer relating to the goods shall be commenced no later than one year from the date of the alleged breach.

**WHO IS COVERED BY THE WARRANTY** - This warranty extends to the Original Retail Purchaser only.

**WHAT IS COVERED BY THIS WARRANTY** - This warranty covers only ATI manufactured products. Any ATI product that, during the term of this warranty, fails to function properly UNDER NORMAL USAGE due to defects in material or workmanship will be repaired by ATI at no charge for parts or labor, or at the option of ATI, the product will be replaced.

**WHAT IS NOT COVERED BY THE WARRANTY** - Damages or malfunctions not resulting from defects in material and workmanship and damages or malfunctions from other than intended use including, but not limited to, improper installation, repair by unauthorized parties, tampering, modification, accident or abuse are not covered by this warranty.

## KEEP THIS FOR YOUR RECORDS!

ATI recommends you retain this Warranty along with your invoice. **For your protection, fill in the information and immediately mail the Purchase Information form below so that we may contact you directly in the event a safety notification is issued.** Also, in order to serve you better, please take a moment to answer the questionnaire on the reverse side of this form. We value your comments!

**ORDER #:** \_\_\_\_\_

**PURCHASE DATE:** \_\_\_\_\_

*If more than one product was purchased, list each part # separately with serial # (if applicable).*

**Part #:** \_\_\_\_\_

**Serial #:** \_\_\_\_\_

**Part #:** \_\_\_\_\_

**Serial #:** \_\_\_\_\_

**Part #:** \_\_\_\_\_

**Serial #:** \_\_\_\_\_

*If not purchased directly from ATI:*

**DEALER:** \_\_\_\_\_

**DEALER'S ADDRESS:** \_\_\_\_\_

\_\_\_\_\_

## WHAT TO DO WHEN SERVICE IS NEEDED

Carefully package the product using ample material (preferably in the original carton) to prevent damage during shipping. **Be sure to drain any fluid left in your converter or transmission!** You may either deliver it or ship it postage prepaid and insured to ATI. Send to:

**ATI PERFORMANCE PRODUCTS, INC.**

**Attention: Service Department**

**6718 Whitestone Road**

**Gwynn Oak, Maryland 21207-9805**

**Phone: (410) 298-4343 • Fax: (410) 298-3579**

When returning items for service, your package must include:

1. A copy of the sales invoice.
2. Product serial number(s).
3. A detailed description of the problem.
4. Daytime and cell phone numbers plus an e-mail address where our technicians can contact you.

**Note! Finished repairs must be picked up or shipped within 30 days or storage fees will occur. After 90 days, they will be subject to sale or disposal by ATI.**

## IF YOU HAVE QUESTIONS OR NEED HELP

If you have questions about the use or performance of your products, or if you have any questions or comments regarding service performed at ATI which has not been resolved to your satisfaction, write directly to: ATI Performance Products, Inc., Attention: Consumer Affairs Department, 6718 Whitestone Road, Gwynn Oak, MD 21207 or send an e-mail to [info@atiracing.com](mailto:info@atiracing.com).

**This warranty gives you specific legal rights. You may also have other rights which vary from state to state.**

# 4 WAYS TO REGISTER YOUR PRODUCT!

So that we may better assist you, please fill in the Purchase Information form below and return to ATI.

- On-line at [www.atiracing.com/warranty](http://www.atiracing.com/warranty) for quick and easy registration!
- E-mail: [info@atiracing.com](mailto:info@atiracing.com)
- Fax: 410-298-3579
- Mail: ATI Performance Products, Inc., Attn: Consumer Affairs, 6718 Whitestone Rd, Gwynn Oak, MD 21207-9805

Name: \_\_\_\_\_

E-Mail: \_\_\_\_\_

Address: \_\_\_\_\_

City: \_\_\_\_\_ State: \_\_\_\_\_ Zip: \_\_\_\_\_

Phone: \_\_\_\_\_ Cell: \_\_\_\_\_

Part(s) Purchased: \_\_\_\_\_ Order #: \_\_\_\_\_

Part # \_\_\_\_\_ Serial Number / SFI # \_\_\_\_\_

\_\_\_\_\_

\_\_\_\_\_

\_\_\_\_\_

Date of Purchase: \_\_\_\_\_ Purchased From: \_\_\_\_\_

Did the Seller meet your expectation: \_\_\_\_\_ If no, explain: \_\_\_\_\_

- With service? \_\_\_\_\_ yes \_\_\_\_\_ no \_\_\_\_\_

- With product knowledge? \_\_\_\_\_ yes \_\_\_\_\_ no \_\_\_\_\_

- With sales help? \_\_\_\_\_ yes \_\_\_\_\_ no \_\_\_\_\_

Other Comments: \_\_\_\_\_

\_\_\_\_\_

\_\_\_\_\_

How did you hear about ATI? _____ _____ _____ _____ _____
---

## PUBLICATIONS YOU READ:

- |                          |                                   |
|--------------------------|-----------------------------------|
| _____ D-Sport            | _____ Mopar Action                |
| _____ Diesel Power       | _____ National Dragster (NHRA)    |
| _____ Drag Racing Edge   | _____ Performance Racing Industry |
| _____ Drag Illustrated   | _____ RPM Magazine                |
| _____ Drag Review (IHRA) | _____ Street Scene (NSRA)         |
| _____ Drive!             | _____ Super Chevy                 |
| _____ Fastest Street Car | _____ Other: _____                |
| _____ Grassroots         | _____                             |
| _____ Hot Rod            | _____                             |

## CHECK ALL THAT APPLY:

### Section 1

- \_\_\_\_\_ Drag Race \_\_\_\_\_ Oval Track \_\_\_\_\_ Street Performance  
\_\_\_\_\_ Truck/Tractor \_\_\_\_\_ Marine Use \_\_\_\_\_ Other \_\_\_\_\_

### Section 2

- \_\_\_\_\_ GM \_\_\_\_\_ Ford \_\_\_\_\_ Chrysler \_\_\_\_\_ Import  
\_\_\_\_\_ Other \_\_\_\_\_

### Section 3

- \_\_\_\_\_ Vehicle Owner \_\_\_\_\_ Do-It-Yourself \_\_\_\_\_ Professional Mechanic  
\_\_\_\_\_ Shop Owner \_\_\_\_\_ Engine Builder \_\_\_\_\_ Race Car Builder  
\_\_\_\_\_ Transmission Builder \_\_\_\_\_ Other \_\_\_\_\_

## WEBSITES & FORUMS:

- |                           |                      |
|---------------------------|----------------------|
| _____ Chevy Hardcore      | _____ Ford NXT       |
| _____ ClassRacer.com      | _____ Instagram      |
| _____ Competition Plus    | _____ LSX Mag        |
| _____ DragRaceResults.com | _____ RacingJunk.com |
| _____ DragtimeNews.com    | _____ YouTube        |
| _____ Dragzine            | _____ Other: _____   |
| _____ Engine Labs         | _____                |
| _____ Facebook            | _____                |