

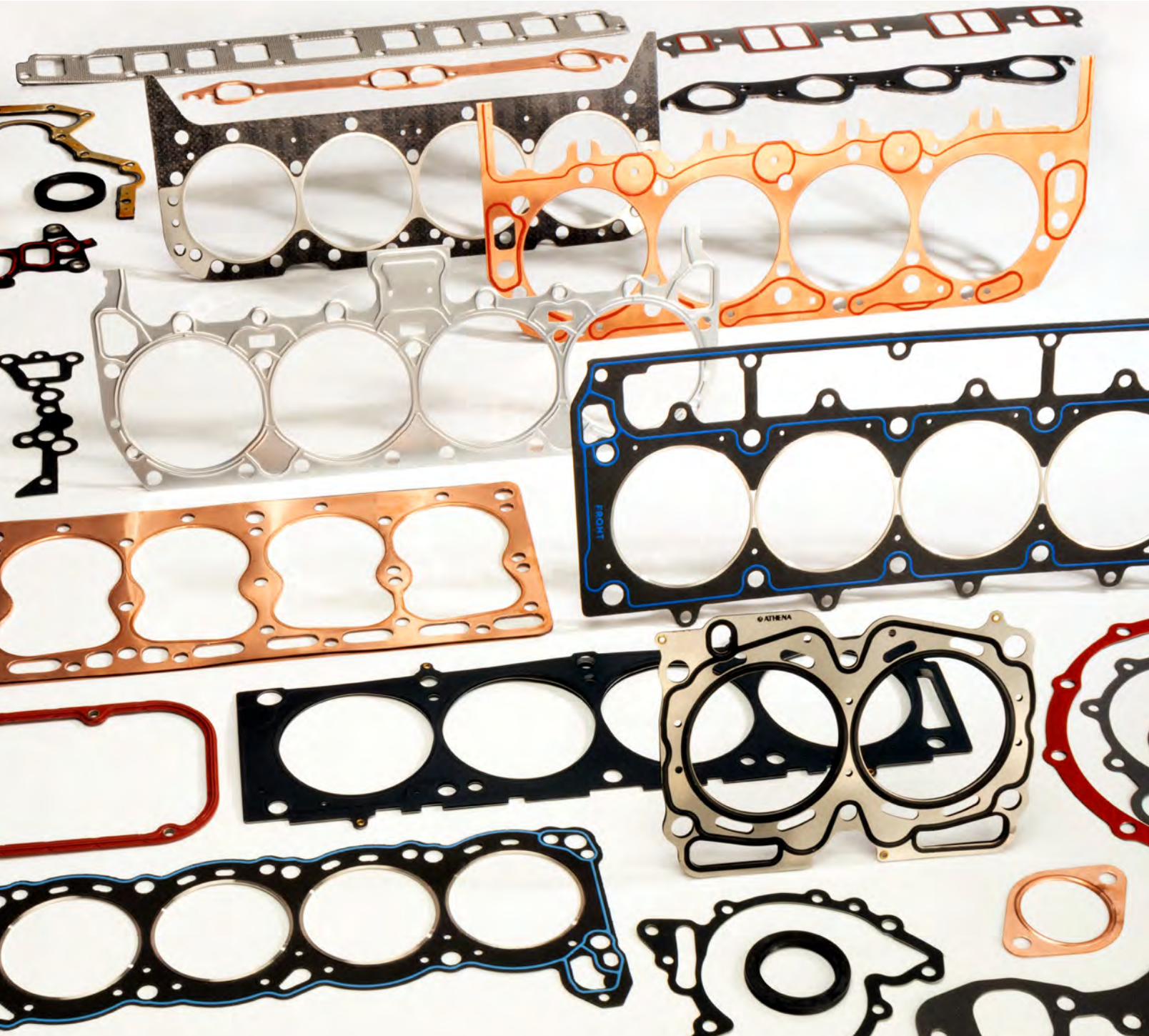

**AUTOMOTIVE  
PERFORMANCE  
CATALOG · 2022 v3**



**DELIVERING HORSEPOWER™**



# Good Things Start in a Garage



*Where it all started — Dan & son, Ryan Hunter, in Dan's garage, 1990.*

Born of a need to supply their own racing engines, my father Ryan and grandfather Dan Hunter laid the foundation for SCE Gaskets in Lancaster, California in April 1990. Initially focused on copper head gaskets for drag racing, Ryan applied his ingenuity to racing engine sealing, creating new and patented products and categories such as Pro-Copper embossed exhaust gaskets, Titan Self-Sealing copper head gaskets, and ICS copper head gaskets with built-in o-rings. SCE's product offering quickly grew to include all types of engine gaskets and seals "from the hat to the pan".

Building on our racing heritage, the SCE Gaskets brand went international, gaining distribution through premier wholesale warehouse partners across the United States, Canada, and Australia. In 2011, our family acquired a gasket manufacturing operation in Spencer, Iowa which further diversified the company's products and customers to include Marine, Industrial, Agricultural, Antique and OE Replacement.

In 2015, we began the search for a location to consolidate our California and Iowa operations for improved production and logistics. In 2017 we selected the picturesque small town of Mount Pleasant, Tennessee as the company's permanent home — about one hour southwest of Nashville.

Today, over 30 years have passed, and the SCE Gaskets brand remains true to its family roots of innovation and vibrant relationships with employees, distribution partners and consumers of its products.

*— Aaron Hunter, Vice President*



*Ryan & son, Aaron Hunter, with Gio Scelzi & BDS Motorsports, Clay County Fair Speedway, Spencer, IA, September 2017.*

1990 SCE Gaskets Founded, California

1995 Pro-Copper Embossed Exhaust

2000 Titan Self-Sealing Copper HG

2005 ICS Copper HG

2011 Iowa Acquisition



# *Strategic Partnership*

While the SCE Gaskets brand was firmly established as a leader in quality, SCE needed access to new & rapidly advancing gasket technologies. Athena, a prominent global manufacturer and technology leader, desired increased access to the American marketplace with a US manufacturing presence. Having already known each other from previous joint projects and sharing a similar family business culture, we began to explore a partnership in early 2017.

Athena S.p.A., located in northern Italy, was founded by Giovanni Mancassola in 1973 as a small artisan manufacturer of industrial gaskets. Today, the company boasts an employee force of over 800 with a worldwide presence, yet remains under the ownership and guidance of its founder and his family.

In May of 2018, the Mancassola and Hunter families launched a new partnership, Athena-SCE, Inc. Under this new corporate umbrella, the SCE Gaskets brand is now unrivaled in its range of performance engine sealing solutions.

SCE has raised the bar for cylinder head sealing performance and consistency. Our new Gas-Stopper enhancement to MLS Spartan head gaskets is an example of superior design, tooling and processes. Our exclusive Vulcan Cut-Ring head gaskets are also an industry first: superb in strength, simplicity and ease of use. Vulcan Cut-Ring reliably seals hyper-boosted, street-driven and competition liquid cooled engines. Also introduced in this catalog, SCE Gaskets has expanded its offerings to include all popular European and Japanese performance engines.

Stay tuned, our future is bright.

– Ryan Hunter, President

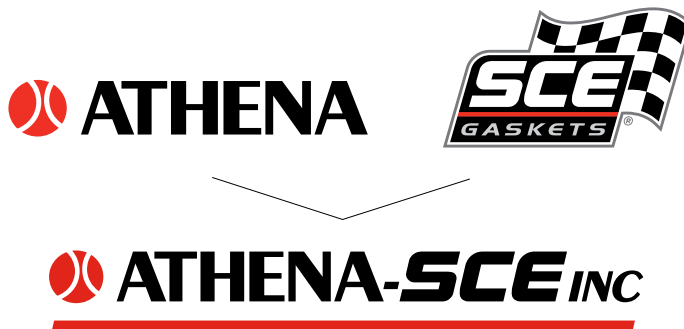

*Gilberto Mancassola, Giovanni's son, and Aaron Hunter at Athena Store, Italy, 2018.*

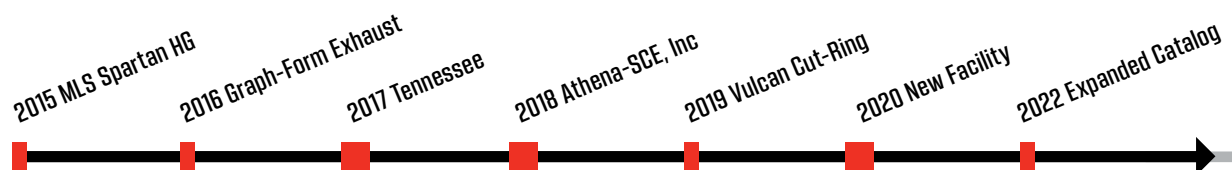



**Intro & Product Info**

<b>History &amp; New Horizons</b> .....	<b>1</b>	<b>Premium Exhaust Gaskets</b> .....	<b>7</b>
<b>NEW Vulcan Cut-Ring Head Gaskets</b> .....	<b>3</b>	<b>NEW SBBK: Short Block Base Kits</b> .....	<b>8</b>
<b>NEW MLS Spartan Head Gaskets</b> .....	<b>4</b>	<b>NEW Athesil RTV Silicone Sealant</b> .....	<b>9</b>
<b>Pro-Copper, Titan, ICS Head Gaskets</b> ....	<b>5</b>	<b>Accu-Seal Pro Premium Engine Gaskets</b> ...	<b>10</b>
<b>Accu-Seal Pro Head Gaskets</b> .....	<b>6</b>	<b>Dyno-Pak Bulk Sets</b> .....	<b>11</b>

**Engine Tables**

AMC V8 .....	12	Ford Modular & Coyote V8 .....	146
Arias, Fontana, MBR .....	15	Ford FE Medium Block .....	151
Audi .....	18	Ford Big Block .....	156
BMW .....	20	GM Inline 4 .....	164
Buick V6 .....	26	Honda .....	169
Buick V8 .....	31	Mitsubishi .....	177
Cadillac 472-500 V8 .....	35	Nissan .....	183
Chevrolet 90° V6 .....	37	Oldsmobile V8 .....	191
Chevrolet Gen I-II Small Block .....	41	Pontiac V8 .....	196
Chevrolet Gen III-IV LS Small Block .....	59	Porsche .....	201
Chevrolet Gen V LT Small Block .....	67	Subaru .....	202
Chevrolet Big Block .....	68	Toyota .....	207
Chrysler Small Block .....	91	Volkswagen .....	214
Chrysler 331-392 Early Hemi .....	99	Blower & Fuel Systems .....	218
Chrysler Wedge & 426 Hemi .....	103	Collector & Turbo .....	222
Chrysler 4.7 & Gen III Hemi .....	115	Rear Axle .....	224
Chrysler · Other Engines .....	116	Accessories · Sealants .....	225
Ferrari .....	120		
Ford 4-5-6 Cylinder .....	121		
Ford Flathead V8 .....	129		
Ford Model A & B .....	130		
Ford Windsor Small Block .....	131		
Ford Cleveland & Modified V8 .....	142		

**Tech Tips**

Part Number Guide .....	226
Head Gasket Application Guide .....	227
Installation Instructions .....	228



# ***VULCAN CUT-RING™***

## **HEAD GASKETS**

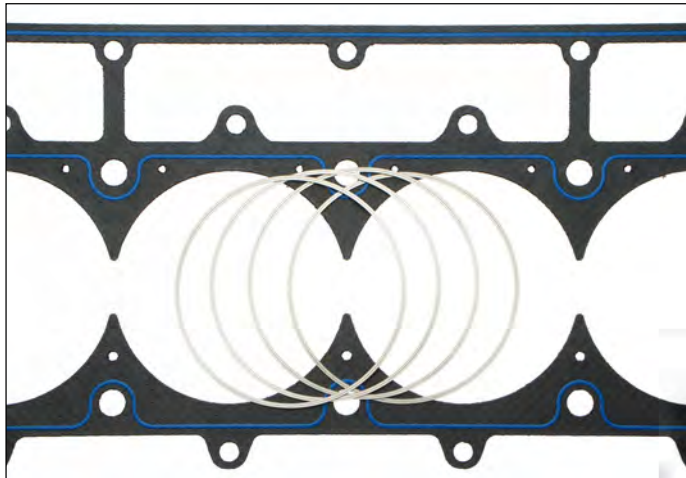

***A hybrid design forged to harness the best sealing properties of two head gasket types.***

### **COMPOSITE BODY**

Pliable, perforated metal-core composite gasket body provides effective sealing of fluids. Polymer coating provides lubricity between gasket and sealing surfaces.

### **STAINLESS STEEL RINGS**

Solid stainless cut-ring 'bites' into the cylinder head forming a positive barrier against combustion pressure leaks. Cut-rings ensure excellent mechanical strength, fixed firmly, in perfect position, on the cylinder head.

### **SILICONE BEAD SEAL**

Silicone bead seal is applied to critical areas. This ensures optimal performance in engine designs, which may be prone to leakage, due to excessive head bolt spacing or deck deflection.

- ▶ ***No Sealant Needed!***
- ▶ ***16:1 Static Compression Ratio***
- ▶ ***No Machining Required***
- ▶ ***35 lbs. Forced Induction***



# MLS SPARTAN™

MULTI-LAYER STAINLESS STEEL HEAD GASKETS

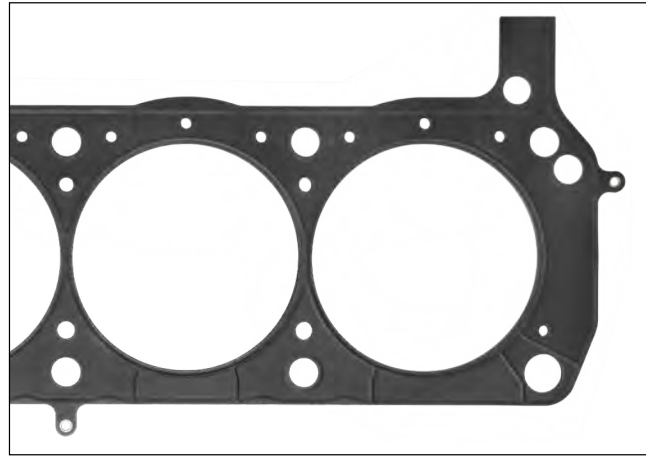

## Strong, Simple to Use & Ready for Battle.

Advanced manufacturing ensures trouble free, bolt-on performance without extra sealants.

Available in 7 thicknesses ranging from .022" to .077"

### No Sealant Required

Constructed of high-grade shape-memory AISI 301 stainless steel. Using state-of-the-art manufacturing processes, the layers maintain optimum flatness. The embossments have uniform molecular grain structure in the radii, which increases spring-contact with the block and head, while reducing stress points within the gasket.



### NEW GAS-STOPPER

Feature on selected applications

Concentrates clamp load at critical sealing areas around combustion chambers.

Seals ~15% more HP over standard MLS.

Look for part numbers with 'GS' suffix.  
Example: M361051GS

# SUPERIOR COPPER GASKETS

## **PRO-COPPER** HEAD GASKETS

- **O-rings required** in block or cylinder head.
- Premium solid copper gaskets
- Available in 8 popular thicknesses
- 99% pure copper, rolled to our specifications and tested for uniform flatness to assure precise cylinder head-to-block alignment and eliminate uneven loading.
- After processing, head gaskets are annealed to achieve complete material normalization. This ensures optimum mating and provides measurable gains in cylinder sealing, as evidenced by lower leak-down percentages.

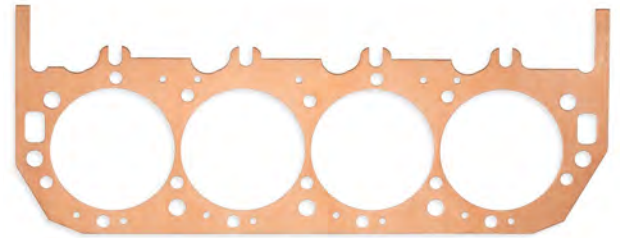

**PRO-COPPER** · Exotic Fuels · Unlimited Boost

## **TITAN** HEAD GASKETS

- **O-rings required** in block or cylinder head.
- **Titan = Pro-Copper + bead seals**
- Coolant & oil seals provide effective fluid containment.
- Patented silicone fluid seals are bonded to both sides of the gasket and offset so that when compressed they lie in a single plane with the gasket body thereby "tripping" additional clamp load to the combustion seal, allowing for increased cylinder sealing.
- Available in 7 popular thicknesses.

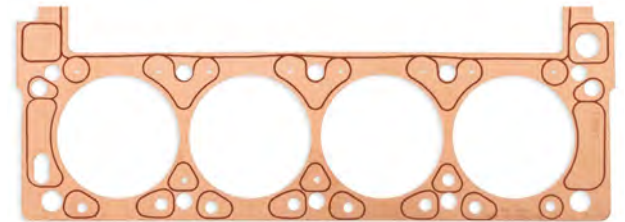

**TITAN** · Liquid-Cooled · Unlimited Boost

## **ICS** HEAD GASKETS

### *Integral Combustion Seal*

- **No O-rings needed** in block or cylinder head.
- **ICS = Pro-Copper + bead seals + o-rings**
- The world's first self-sealing copper head gasket.
- Features stainless steel O-ring wire inserted into the gasket body around the cylinder bore. Combustion pressure forces the flanges against the head and block for a self-energizing seal.
- ICS seal provides dependable combustion sealing in racing classes that prohibit o-ringing.
- Coolant & oil seals included.
- Available in 6 popular thicknesses.

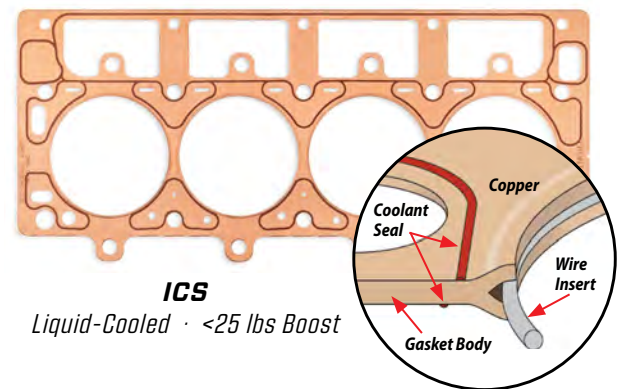

**ICS**  
Liquid-Cooled · <25 lbs Boost



# **ACCU-SEAL PRO™**

*for AMC, Chrysler, Ford & GM Muscle Cars*

## **COMPOSITE / STEEL-CORE HEAD GASKETS**

SCE Accu-Seal Pro composite head gaskets are the ideal solution for the performance aftermarket. Strong and easy to use, SCE performance head gaskets are manufactured with the right combination of materials and features for easy and dependable use on real-world, high compression, street/strip power plants.

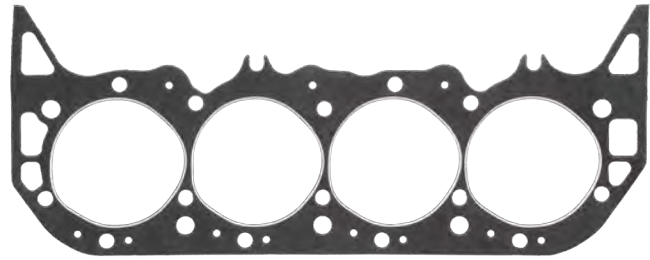

### **FEATURES**

Compressible body construction

Self - Sealing coating

Silicone Bead Seals (where required)

Extra Thick Fire Rings

### **BENEFITS**

Accepts Standard Surface Finish

No need for additional sealants and no leaks

Enhanced coolant sealing

Stronger Combustion Seal

## **EMBOSSSED STEEL SHIM HEAD GASKETS**

SCE re-introduces classic steel shim head gaskets for high compression use. Stock Eliminator and Super Stock class rules do not allow machining to install o-rings for copper head gaskets. Consequently, racers in these classes use steel shim head gaskets for strength and to 'pump up' their compression ratios. Over the last several years embossed steel shim head gaskets have been hard to find, until now. Super thin, super strong OEM style shim steel head gaskets are once again available for select performance applications.



### **FEATURES**

Single-layer steel

Embossments at seal locations

### **BENEFITS**

Accepts Standard Surface Finish

No need for additional sealants and no leaks

# EXHAUST GASKETS

## ACCU-SEAL E

- **Best Use:** Street performance, headers, or stock manifolds.
- .062" thick, high-temperature aramid fiber & graphite material.
- Provides stability & maximum torque retention.

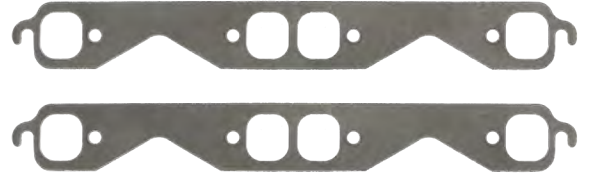

## ACCU-SEAL PRO

- **Best Use:** Racing, turbo-charged, high-temperature.
- .062" thick, aramid fiber & graphite with perforated steel-core.
- Perforated steel core provides stability & maximum torque retention.
- Conforms to header sealing beads & cylinder head surface imperfections.



## GRAPH-FORM

- **Best Use:** Excellent seal for warped, pitted, or uneven manifolds or headers.
- .150" thick, ultra-high-temperature graphite and aramid fiber material.
- Flexible graphite header and collector gaskets compress up to 50%.



## PRO-COPPER EMBOSSSED EXHAUST & COLLECTOR GASKETS

- **Best Use:** Premium solution for racing, turbo-charged, & exotic fuels.
- Embossments around exhaust ports conform & seal header, manifold, or collector flange surfaces.
- Solid copper exhaust gaskets eliminate exhaust gasket leaks — will not shrink, deteriorate, or blow-out.
- Available for applications ranging from specialized racing engines to OEM replacement.
- .043" Embossed • .062" Annealed



**NEW**

# ***SBBK***

## ***— SHORT BLOCK BASE KITS —***



### ***All the essentials you need for assembling short-blocks***

- ▶ Provides remaining gaskets and seals common to the engine type, regardless of customization.
- ▶ Premium kits available with FKM rear main seal.
- ▶ Standard kits include silicone or polyacrylate rear main seal.
- ▶ Contains gaskets for timing cover (oiling system as required), water pump, fuel pump, water outlet, seals for front cover and rear main.
- ▶ Premium Composite Material.



**NEW**

# **ATHESIL**

## **RTV SILICONE SEALANT**



***Designed specifically for high-performance engines.***

Our new single-component RTV silicone answers the needs of professionals in the **automotive, marine, motorcycle, heavy duty, & off-road** industries.

Athesil bonds, seals, repairs, secures, and is excellent for formed-in-place gasketing (FIPG).

***Testing confirms superior performance of Athesil even under extreme conditions:***

**THERMALLY STABLE:**

- -40°F to 430° F performing even at 572° F peaks.
- Resists aging, weathering, & thermal cycling without hardening, shrinking, or cracking.
- Will not damage exhaust system lambda sensors.
- **Test:** Resistance at 500° F.

**SUPERIOR RESISTANCE TO FLUIDS:**

- Resists oils, fuels, greases, coolants, & detergents — ensuring ideal shape retention & adhesion to surfaces.
- Other silicones tend to absorb gasoline, oil & other liquids causing deformation.
- **Test:** Resistance & non-deformation when soaked in gasoline.

**EASY TO APPLY & EASY TO CLEAN UP:**

- Excellent filling & self-leveling properties allow for easy application on both horizontal & vertical surfaces.
- Easily-peelable for fast removal during service.
- **Tests:** non-shrinkage, self-leveling, & peelability.



P/N: G1613 / 1 pc  
2.7 oz · 80 ml · Each tube includes applicator tip & tube squeeze key

G1613-12 / Master-Pak 12 pc

# **ACCU-SEAL PRO™**

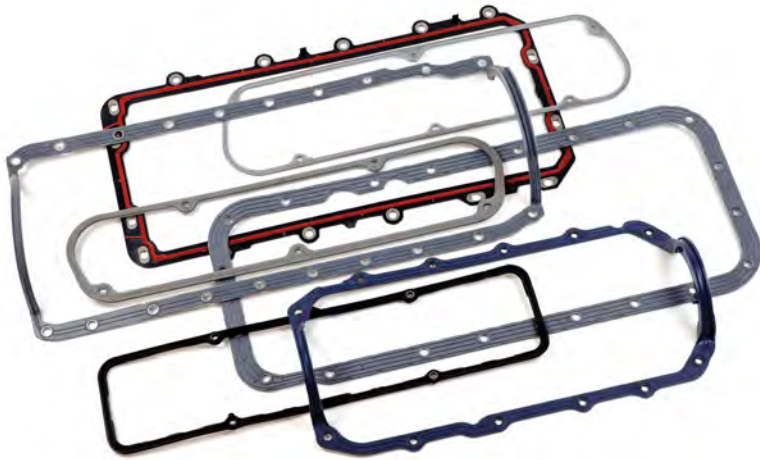

## **MOLDED Rubber Oil Pan & Valve Cover Gaskets**

- State-of-the-art molded silicone rubber gaskets for all popular oil pan and valve cover applications.
- Each gasket has built-in crush limiters to prevent damage from over-tightening.

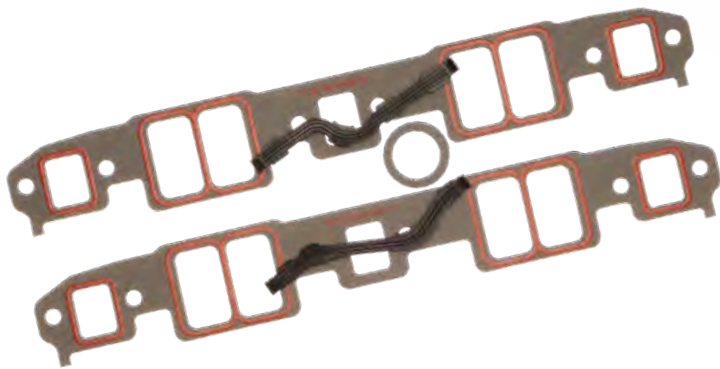

## **PREMIUM Intake Gaskets**

- Premium gasket body materials seal tight,
- Resists weeping of oil & coolant.
- Silicone Beads on most Accu-Seal Pro Intake gaskets enhance sealing around intake ports and coolant passages.
- Release coating for easy clean-up.



## **TUFF-BAK™ Valve Cover Gaskets**

- Provides lateral strength for high vacuum engine applications and blowout protection.
- Designed to seal porous cast iron head rail surfaces or machined cast aluminum rail surfaces.
- Available in .125" and .250" thicknesses. .250" gasket thickness also provides additional rocker arm clearance.

# **DYNO-PAK™**

..... **BULK SETS** .....

## ***Bulk 10-Packs for Engine Builders***

Dyno-Paks are tailor-made for engine builders and other volume gasket users. Each pack contains 10 complete sets of the gaskets or seals you specify, clearly marked and shipped in a reusable box to protect your investment. Our 10-set bulk program is small enough to make sense, yet still offers discounts up to 20% off the individual package price.

If you're an engine builder, make sure you stock your supply room with SCE Dyno-Paks and reap the benefits of extra profits.



**Dyno-Pak part numbers** are designated by a **"-10"** suffix & listed adjacent to each individual part number.

Select products available in packs of **100**, designated by suffix **"-B"**.

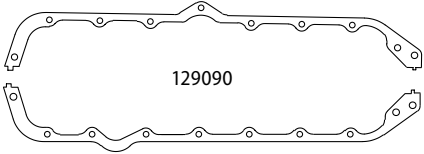

### AMC V8 · Short Block Gaskets & Seals

Application	Oil Pan Gasket Set	Timing Cover Gasket Kit	Front Cover Gasket Set TC · WP · FP	Water Pump Gasket Set	Fuel Pump Gasket	Water Outlet Gasket	Timing Cover Oil Seal	Rear Main Oil Seal	Qty.
1966-78 V8 304-401 ci 5.0-6.6 L	 <p style="text-align: center;">129090</p> <p style="text-align: center;"><b>Accu-Seal E</b> standard gasket materials, nitrile or silicone seals.</p> <p style="text-align: center;">* OEM-style 4-pc set w/ rubberized fiber rails (end seals not pictured).</p>								
	129090 *	12903	12900	12904	11106 <i>supersedes</i> 12906	12908	12902	12905 2 Pc.	1 Set
	29090-10 *	—	2900-10	—	1106-10 <i>supersedes</i> 2906-10	2908-10	2902-10	2905-10	Dyno-Pak 10 Sets

**NEW!**  
— SEE P. 8 —

### AMC V8 · **SBBK** – Short Block Base Kit

Provides remaining gaskets & seals common to the engine type, regardless of customization.

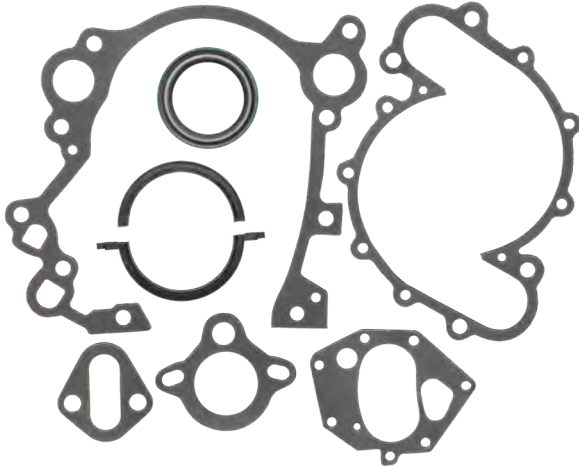
Application	SBBK Gasket / Oil Seal Kit	Contents of Kit
1966-78 V8 304-401 ci 5.0-6.6 L	32903	<p style="text-align: center;"><b>Includes:</b> Timing Cover · Water Pump · Fuel Pump · Water Outlet · Timing Cover Seal · 2-pc Rear Main Seal</p> 

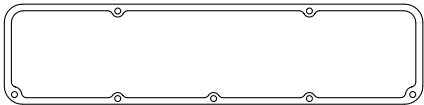

### AMC V8 · Valve Cover Gaskets

Application	Molded Silicone Rubber	Hi-Density Cork 5/16" Thick	Tuff-Bak Laminated Cork		Steel-Core PTFE-Coated .093" Thick	Qty.
			1/8" Thick	1/4" Thick		
	Street / Strip		Racing / Hi-Vac		Severe Duty™	
1966-78 V8 304-401 ci 5.0-6.6 L	 <p style="text-align: right;">7 bolts, 2-over-5 pattern</p>					
	—	129076	229075	229076	—	1 Set
	—	29076-10	229075-10	229076-10	—	Dyno-Pak 10 Sets

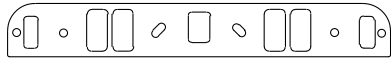
### AMC V8 · Intake Gaskets

Application — Port Size	Thickness	Accu-Seal E · Standard Materials		Accu-Seal Pro · Premium Materials	
		Packaged 1 Set	Dyno-Pak · 10 Sets	Packaged 1 Set	Dyno-Pak · 10 Sets
1966-78 V8 304-401 ci 5.0-6.6 L — 1.12" x 2.29"	 <p>Fits all stock configuration V8 cylinder heads. — † Silicone Bead Sealed Ports</p>				
	.062"	129101	29101-10	229101 †	229101-10 †
	.120"	129106	29106-10	—	

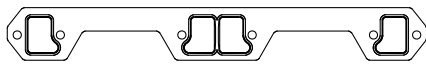
### AMC V8 · Exhaust Gaskets

Application — Port Size	Accu-Seal E		Accu-Seal Pro		Graph-Form	Pro-Copper	
	Standard Material .062"		Premium Material .062"		Hi-Density Graphite .150"	Embossed .043"	Flat-Annealed .062"
	Packaged 1 Set	Dyno-Pak 10 Sets	Packaged 1 Set	Dyno-Pak 10 Sets	Packaged 1 Set	Packaged 1 Set	Packaged 1 Set
1970-79 V8 304-401 ci 5.0-6.6 L — 1.14" x 1.68"	 <p>Dog Leg Port</p>						
	129080	29080-10	229080	29180-10	429080	4029	E29186
1966-69 V8 290-390 ci 4.7-6.4 L — 1.20" x 1.54"	 <p>Rectangle Port</p>						
	129081	29081-10	229081	29181-10	429081	—	E29286

### AMC V8 · Accu-Seal Pro · Performance Head Gaskets

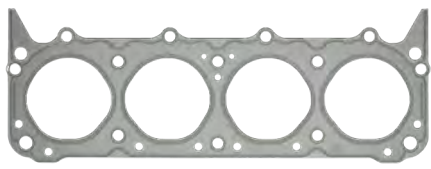
Application	Image	Bore Opening	Compr. Thick.	Part Number	Description	Qty.
1967-81 V8 290-304 ci 4.8-5.0 L		3.840"	0.020"	5298420	Embossed steel shim construction.	1

**AMC V8 · MLS Spartan · Performance Head Gaskets**

Application	Image	Bore Opening	Compr. Thick.	Part Number	Description	Qty.
1966-78 V8 304-401 ci 5.0-6.6 L		4.250"	.039"	M292539	MLS embossed stainless steel construction.	1
		4.380"	.039"	M293839		1
<p><b>Marine Use:</b> stainless steel construction, all MLS Spartan head gaskets are suitable for use in marine applications.</p>						

**AMC · 1966-78 · V8 · 304-401 ci · 5.0-6.6 L**

**Pro-Copper Racing Head Gaskets**  
For use with o-rings & sealant

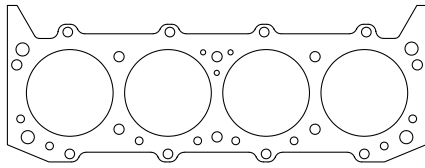
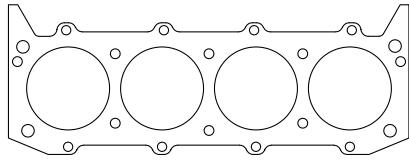
No water holes: use suffix "NW"

Bore Opening	Thickness								Qty.
	.021"	.032"	.043"	.050"	.062"	.072"	.080"	.093"	
4.200" round	P292021	P292032	P292043	P292050	P292062	P292072	P292080	P292093	1
4.250" round	P292521	P292532	P292543	P292550	P292562	P292572	P292580	P292593	1

**Titan Copper Racing Head Gaskets**  
Sealed coolant passages, for use with o-rings

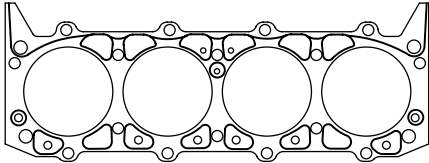

Bore Opening	Thickness								Qty.
	.021"	.032"	.043"	.050"	.062"	.072"	.080"	.093"	
4.200" round	–	T292032	T292043	T292050	T292062	T292072	T292080	T292093	1
4.250" round	–	T292532	T292543	T292550	T292562	T292572	T292580	T292593	1

**ICS Copper Racing Head Gaskets**  
Sealed coolant passages, integral combustion o-ring

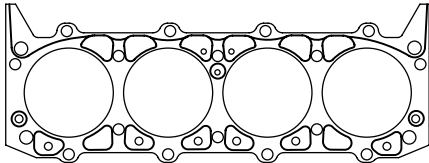

Bore Opening	Thickness								Qty.
	.021"	.032"	.043"	.050"	.062"	.072"	.080"	.093"	
4.200" round	–	–	S292043	S292050	S292062	S292072	S292080	S292093	1
4.250" round	–	–	S292543	S292550	S292562	S292572	S292580	S292593	1

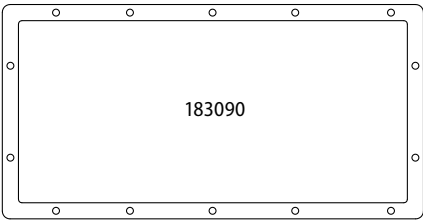

**Arias · Fontana · MBR · Short Block Gaskets & Seals**

Application	Oil Pan Gasket	Water Pump Gasket Set	Front Cover Gasket	Fuel Pump Gasket	Water Outlet Gasket	Timing Cover Oil Seal	Rear Main Oil Seal	Qty.
<b>Arias, Fontana, &amp; MBR</b> • <b>All 8.3 L &amp; 10 L Engines</b>	 <p style="text-align: center;">183090</p> <p style="text-align: right;"><b>Accu-Seal E</b> standard gasket materials, nitrile or silicone seals. * 1-pc · Fuel-resistant material</p>							
	183090 *	-	-	-	18501	11302	11305 ‡	1 Set
	83090-10 *	-	-	-	8501-10	1302-10	1305-10 ‡	Dyno-Pak 10 Sets
	<b>Accu-Seal Pro</b> premium gasket materials, FKM seals, molded water outlet. † 1-piece · Severe Duty™, .093" thick PTFE-coated, steel-core material. • ‡ With 2.75" Chevrolet main journal							
	283090 †	-	-	-	-	21302	21305 ‡	1 Set
	283090-10 †	-	-	-	-	21302-10	21305-10 ‡	Dyno-Pak 10 Sets

**Arias · Fontana · MBR · Valve Cover Gaskets**

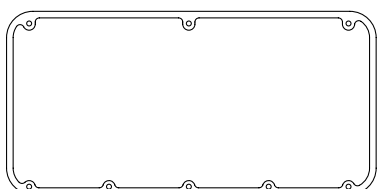
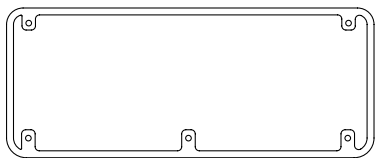
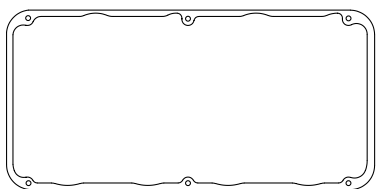
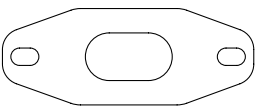
Application	Molded Silicone Rubber	Hi-Density Cork 5/16" Thick	Tuff-Bak Laminated Cork		Fuel Resistant Fiber 5/8" Thick	Steel-Core PTFE-Coated .093" Thick (3/32")	Qty.
			1/8" Thick	1/4" Thick			
	Street / Strip		Competition / Hi-Vac		Sportsman Racing	Severe Duty™	
<b>Early Arias 11.25" Wide</b>					183075	283075	1 Set
					-	-	Dyno-Pak 10 Sets
<b>Fontana &amp; MBR 8.3 L Billet</b>					184075	284075	1 Set
					84075-10	84175-10	Dyno-Pak 10 Sets
<b>Arias Chevy-Hemi</b>					185075	285075	1 Set
					18075-10	285075-10	Dyno-Pak 10 Sets
<b>Universal Valve Cover Breather Gaskets</b>	 <p style="text-align: center;">2 bolts, standard shape fits all popular breathers. — Δ Meets NHRA breather gasket rules.</p>				16604	26604 Δ	1 Set
					16604-10	26604-10 Δ	Dyno-Pak 10 Sets

**Arias · Fontana · MBR · Intake Gaskets**

Application — Port Size	Thickness	Accu-Seal E Standard Material		Accu-Seal Pro · Premium Materials	
		Packaged 1 Set	Dyno-Pak · 10 Sets	Packaged 1 Set	Dyno-Pak · 10 Sets
Early 8.3 L & 10 L Cast Heads — 2.12" x 2.22"					
	.062"	183101	83101-10	283101	283101-10
Raised Port Cast & Billet 8.3 L Heads — 2.20" x 2.00"					
	.062"	183102	83102-10	283102	283102-10
Arias Chevy-Hemi — 2.20" x 2.00"					
	.062"	185101	185101-10	285101	285101-10
Arias Chevy-Hemi Valley Cover Gasket					
	.062"	18510	18510-10	28510	28510-10

**Arias · Fontana · MBR · Exhaust Gaskets**

Application — Port Size	Accu-Seal E		Accu-Seal Pro		Pro-Copper	
	Standard Material .062"		Premium Material .062"		Embossed .043"	Flat-Annealed .062"
	Packaged 1 Set	Dyno-Pak 10 Sets	Packaged 1 Set	Dyno-Pak 10 Sets	Packaged 1 Set	Packaged 1 Set
Arias, Fontana, & Arias Chevy-Hemi · All 8.3 L & 10 L Engines — 2.55" x 2.04"						
	183081	83081-10	283081	283081-10	4083	E83186
MBR 8.3 L w/ Raised Ports — 2.55" x 2.04"						
	-	-	-	-	4183	-

**Arias/B&B · 10 L**

**Pro-Copper  
Racing Head Gaskets**

For use with o-rings & sealant

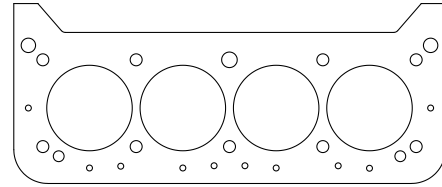

Bore Opening	Thickness						Qty.
	.043"	.050"	.062"	.072"	.080"	.093"	
4.440" round	P104443	P104450	P104462	P104472	P104480	P104493	1
4.520" round	P105243	P105250	P105262	P105272	P105280	P105293	1

**Arias/B&B · 8.3 L · Cast Aluminum Block · Round Bore**

**Pro-Copper  
Racing Head Gaskets**

For use with o-rings & sealant

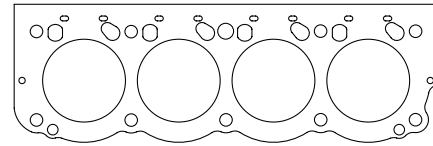

Bore Opening	Thickness						Qty.
	.043"	.050"	.062"	.072"	.080"	.093"	
4.380" round	P833843	P833850	P833862	P833872	P833880	P833893	1
4.440" round	P834443	P834450	P834462	P834472	P834480	P834493	1
4.470" round	P834743	P834750	P834762	P834772	P834780	P834793	1
4.520" round	P835243	P835250	P835262	P835272	P835280	P835293	1

**Fontana/MBR · 8.3 L · Billet Aluminum Block**

**Pro-Copper  
Racing Head Gaskets**

For use with o-rings & sealant

with pocket  
for 2.640"  
intake valve

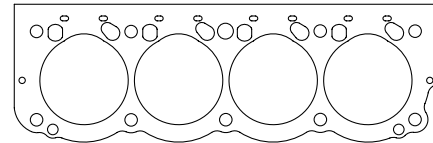

Bore Opening	Thickness						Qty.
	.043"	.050"	.062"	.072"	.080"	.093"	
4.380"	P843843	P843850	P843862	P843872	P843880	P843893	1
4.440"	P844443	P844450	P844462	P844472	P844480	P844493	1
4.470"	P844743	P844750	P844762	P844772	P844780	P844793	1
4.520"	P845243	P845250	P845262	P845272	P845280	P845293	1

**Audi · MLS Spartan · Performance Head Gaskets**

Application	Image	Bore Opening	Compr. Thick.	Part Number	Description	Qty.
1.4-1.6 L 85-98 ci 2006-Up L4 · AXX / BPYBWA / BYD		84.0 mm 3.307"	1.0 mm .039"	M338433GS	MLS Spartan with <b>Gas-Stopper</b> embossed stainless steel construction.	1
1.6-1.8 L 98-109 ci 1991-96 L4 · ADR / AEBAFY / ARK		83.0 mm 3.268"	1.4 mm .055"	M338003GS		1
1.6-1.8 L 98-109 ci 1991-Up L4 · ADR / AEBAFY / ARK		82.0 mm 3.229"	1.3 mm .053"	M338463GS		1
		83.0 mm 3.268"	1.3 mm .053"	M338253GS		1
		84 mm 3.300"	1.2 mm .049"	M338254GS		1
1.8 L 109 ci 1978-92 L4 DZ / DS / JN / JV		81.0 mm 3.189"	1.4 mm .055"	M338419GS	1	
2.0 L 121 ci 2004- Up L4		84.6 mm 3.331"	0.9 mm .035"	M338486	MLS embossed stainless steel construction	1
<p><b>Marine Use:</b> stainless steel construction, all MLS Spartan head gaskets are suitable for use in marine applications.</p>						



**Audi · Vulcan Cut-Ring · Performance Head Gaskets**

Application	Image	Bore Opening	Compr. Thick.	Part Number	Description	Qty.
<b>1.9-2.2 L</b> <b>116-135 ci</b> <b>1981-85</b> <b>L5</b>		82.0 mm 3.23"	1.6 mm .063"	CR330047	Stainless steel Cut-Ring combustion seals (not pictured).  Composite gasket body construction.	1
		83.6 mm 3.29"	1.6 mm .063"	CR330048		1
<b>2.5 L</b> <b>152 ci</b> <b>2009-Up</b> <b>L5</b>		84.1 mm 3.31"	1.4 mm .055"	CR330072		
<b>2.5 L</b> <b>152 ci</b> <b>2009-Up</b> <b>A3, RS3, Q3-RS,</b> <b>TT-RS</b>		83.5 mm 3.288"	1.4 mm .056"	CR330117		1

**BMW · MLS Spartan · Performance Head Gaskets**

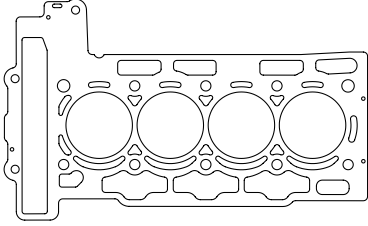
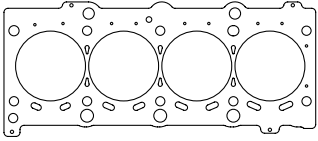
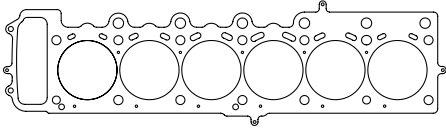
Application	Image	Bore Opening	Compr. Thickness	Part Number	Description	Qty.
<b>2007-2015</b> <b>EP6 / EP6C</b> <b>L4</b> <b>Mini Cooper</b> <b>1.6 L</b> <b>98 ci</b>		78.5 mm 3.091"	0.9 mm .035"	M338476GS	MLS Spartan with <b>Gas-Stopper</b> embossed stainless steel construction.	1
<b>1989-97</b> <b>E30 / E36</b> <b>M42B18</b> <b>L4</b> <b>1.8 L</b> <b>110 ci</b>		87.0 mm 3.426"	1.6 mm .063"	M338287	MLS Spartan embossed stainless steel construction.	1
<b>1992-01</b> <b>S50B30</b> <b>E36 M3 / Z3 M</b> <b>L6</b> <b>3.0 L</b> <b>181 ci</b>		87.0 mm 3.426"	1.8 mm .071"	M338081		1

**Marine Use:** stainless steel construction, all MLS Spartan head gaskets are suitable for use in marine applications.

## BMW · Vulcan Cut-Ring · Performance Head Gaskets

Application	Image	Bore Opening	Compr. Thickness	Part Number	Description	Qty.
1989-97 M42B18 E30 / E36 L4 1.8 L 110 ci		86.5 mm 3.406"	2.0 mm .079"	CR330075	Stainless steel Cut-Ring combustion seals (not pictured).  Composite gasket body construction.	1
2011-2017 N20B20 F10-F34 L4 2.0 L 121 ci		85.0 mm 3.347"	1.2 mm .047"	CR330070		1
1986-1991 S14 E30 M3 2.0-2.3 L 121 ci		95.0 mm 3.741"	2.0 mm .079"	CR330021		1
1991-1996 M20 E30 / E34 · L6 2.5-2.7 L 152-170 ci		85.5 mm 3.367"	2.0 mm .079"	CR330015		1
1989-2000 M50B25, M52B25-B28, S50B30 L6 2.5-3.0 L 152-183 ci		84.5 mm 3.327"	2.0 mm .079"	CR330012		1
		85.5 mm 3.366"	2.0 mm .079"	CR330144		1
		86.0 mm 3.386"	1.6 mm .063"	CR330011		1
			2.0 mm .079"	CR330013		1
		87.0 mm 3.426"	1.6 mm .063"	CR330014		1
2000-06 M54 E36 - E60 L6 2.5-3.0 L 152-183 ci		84.5 mm 3.327"	2.0 mm .079"	CR330141		1
		86.0 mm 3.386"	1.5 mm .059"	CR330022	1	
		87.6 mm 3.449"	1.5 mm .059"	CR330023	1	
10/2002-2006 E46 320i, 325i, 330i, 320i, 325i, 330i L6 2.5-2.8 L 152-170 ci		87.6 mm 3.449"	1.5 mm .059"	CR330023	1	

**BMW · Vulcan Cut-Ring · Performance Head Gaskets**

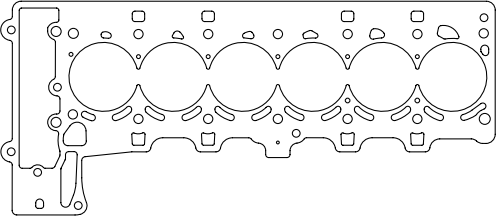
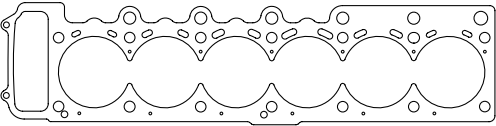
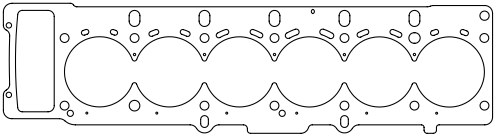
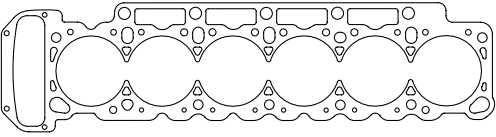
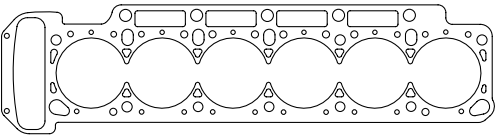
Application	Image	Bore Opening	Compr. Thickness	Part Number	Description	Qty.	
2005-Up N52-N54 L6 E8X-F01 3.0 L 183 ci		86.0 mm 3.386"	1.5 mm .059"	CR330074	Stainless steel Cut-Ring combustion seals (not pictured).	1	
1992-2000 S50 · L6 E36 M3 / Z3 M 3.0-3.2 L 183-195 ci		87.1 mm 3.430"	1.8 mm .071"	CR330020		1	
2000-11 S54 · L6 E36 / E37 / E46 / M3 / B32 3.2 L · 195 ci		87.5 mm 3.445"	1.2 mm .047"	CR330037		1	
		88 mm 3.46"	1.2 mm .047"	CR330077		1	
1979-88 M30B34 - M30B35LE E12, E23, E24, E28, & M1 ProCar 3.4-3.5 L 208-214 ci		93.1 mm 3.666"	2.0 mm .079"	CR330016		Composite gasket body construction.	1
		95.0 mm 3.740"	1.30 mm .051"	CR330061			1
		95.6 mm 3.764"	2.0 mm .079"	CR330017	1		
1974-76 M49 E9 CSL 3.5 L 214 ci		95.0 mm 3.740"	1.30 mm 0.51"	CR330069		1	



## BMW · Vulcan Cut-Ring · Performance Head Gaskets

Application	Image	Bore Opening	Compr. Thickness	Part Number	Description	Qty.
<b>1993-1996</b> <b>M60B40</b> <b>V8</b> <b>E31 / E32 /</b> <b>E34 / E38</b> <b>4.0 L</b> <b>244 ci</b>		90.6 mm 3.567"	2.0 mm .079"	CR330024 <i>Right</i>	Stainless steel Cut-Ring combustion seals (not pictured).  Composite gasket body construction.	1
			2.0 mm .079"	CR330025 <i>Left</i>		1
<b>1996-05</b> <b>M62B44 /</b> <b>M62B46</b> <b>Alpina / E31 /</b> <b>E38 / E39 /</b> <b>E53 / Morgan /</b> <b>Range Rover</b> <b>4.4-4.6 L</b> <b>268-281 ci</b>		93.6 mm 3.686"	2.0 mm .079"	CR330026 <i>Right</i>		1
			2.0 mm .079"	CR330027 <i>Left</i>	1	
<b>2011-Up</b> <b>N63 /</b> <b>N63TU / S63</b> <b>F01 / F02 / F10 /</b> <b>F16 / F85 / F86</b> <b>4.4 L</b> <b>268 ci</b>		90.5 mm 3.563"	1.1 mm .043"	CR330073	1	

**BMW • Formula 2 • L4 • 2.0 L • 121 ci**

**Pro-Copper  
Racing Head Gaskets**

For use with o-rings & sealant

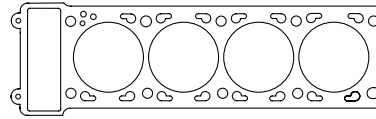

Bore Opening	Thickness							Qty.
	.032"	.043"	.050"	.062"	.072"	.080"	.093"	
84.7 mm round 3.335"	P909132	P909143	P909150	P909162	P909172	P909180	P909193	1

**BMW • M20/B20-B27 • SOHC L6 • 1977-83 • 2.0-2.7 L • 122-165 ci**

**Pro-Copper  
Racing Head Gaskets**

For use with o-rings & sealant

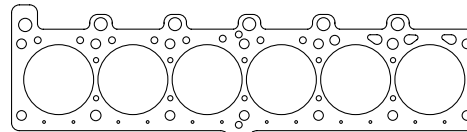

Bore Opening	Thickness							Qty.
	.032"	.043"	.050"	.062"	.072"	.080"	.093"	
93.2 mm round 3.670"	P909032	P909043	P909050	P909062	P909072	P909080	P909093	1

**BMW • M52/B25-B28 • DOHC L6 • 1995-2000 • 2.5-2.8 L • 152-170 ci**

**Pro-Copper  
Racing Head Gaskets**

For use with o-rings & sealant

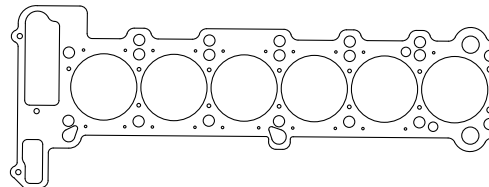

Bore Opening	Thickness							Qty.
	.032"	.043"	.050"	.062"	.072"	.080"	.093"	
84.7 mm round 3.335"	P910432	P910443	P910450	P910462	P910472	P910480	P910493	1

**BMW • M54/B22-B30 • DOHC L6 • 2000-06 • 2.2-3.0 L • 134-183 ci**

**Pro-Copper  
Racing Head Gaskets**

For use with o-rings & sealant

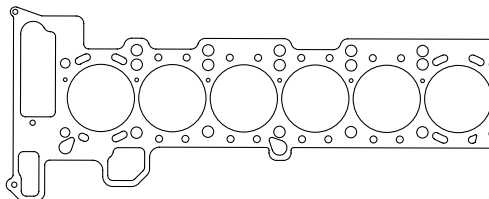

Bore Opening	Thickness							Qty.
	.032"	.043"	.050"	.062"	.072"	.080"	.093"	
84.7 mm round 3.335"	P929532	P929543	P929550	P929562	P929572	P929580	P929593	1

**BMW • M30 • SOHC L6 • 2.5-3.5 L • 152-214 ci**

**Pro-Copper  
Racing Head Gaskets**

For use with o-rings & sealant

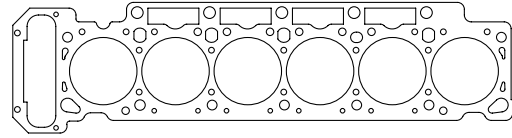

Bore Opening	Thickness							Qty.
	.032"	.043"	.050"	.062"	.072"	.080"	.093"	
93.2 mm round 3.670"	P910232	P910243	P910250	P910262	P910272	P910280	P910293	1

**BMW • M60B40 • DOHC V8 • 1992-01 • 3.0-4.0 L • 183-244 ci**

**Pro-Copper  
Racing Head Gaskets**

For use with o-rings & sealant

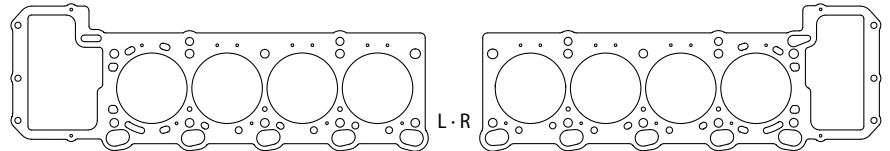

Bore Opening	Thickness							Qty.
	.032"	.043"	.050"	.062"	.072"	.080"	.093"	
92 mm round 3.622"	-	-	P957850L P957850R	P957862L P957862R	P957872L P957872R	P957880L P957880R	P957893L P957893R	1
93.2 mm round 3.670"	-	-	P909250L P909250R	P909262L P909262R	P909272L P909272R	P909280L P909280R	P909293L P909293R	1

**BMW • S54B32 • L6 • 2000-08 • 3.2 L • 198 ci**

**Pro-Copper  
Racing Head Gaskets**

For use with o-rings & sealant

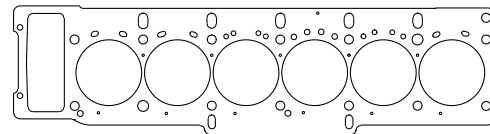

Bore Opening	Thickness							Qty.
	.032"	.043"	.050"	.062"	.072"	.080"	.093"	
87.3 mm round 3.437"	P925332	P925343	P925350	P925362	P925372	P925380	P925393	1

**BMW • S38B35 • L6 • 1987-93 • 3.5 L • 212 ci**

**Pro-Copper  
Racing Head Gaskets**

For use with o-rings & sealant

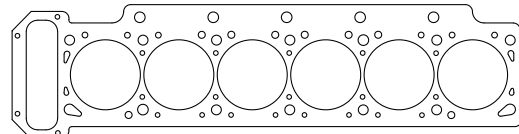

Bore Opening	Thickness							Qty.
	.032"	.043"	.050"	.062"	.072"	.080"	.093"	
88.9 mm round 3.500"	P910532	P910543	P910550	P910562	P910572	P910580	P910593	1
93.2 mm round 3.670"	P910232	P910243	P910250	P910262	P910272	P910280	P910293	1
94.6 mm round 3.725"	P910332	P910343	P910350	P910362	P910372	P910380	P910393	1

**Buick 231 ci V6 · Short Block Gaskets & Seals**

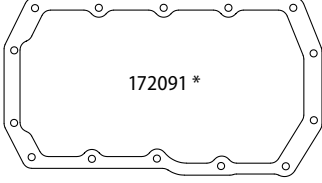
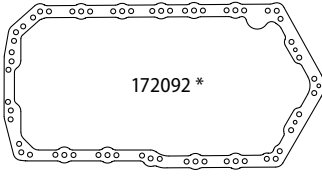
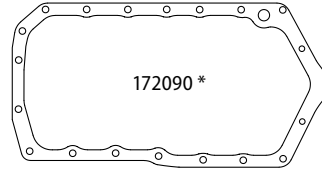
Application	Oil Pan Gasket Set	Front Cover Gasket Set TC · WP · FP	Water Pump Gasket Set	Oil Pump Gasket	Fuel Pump Gasket	Water Outlet Gasket	Timing Cover Seal	Rear Main Oil Seal	Qty.
<b>1975-85 Stage 1 &amp; 2 14-bolt Oil Pan</b>	 <p><b>172091 *</b></p> <p><b>Accu-Seal E</b> standard gasket materials, nitrile or silicone seals.</p> <p>—</p> <p>* OEM-style 1-pc gasket, rubberized fiber.</p>								
	172091 *	17200	17204	17203	11106 <i>supersedes</i> 17206	17208	17202	17205	1 Set
	72091-10 *	7200-10	—	—	1106-10 <i>supersedes</i> 7206-10	7208-10	7202-10	7205-10	Dyno-Pak 10 Sets
<b>1984-89 RWD 20-bolt Stock Oil Pan</b>	 <p><b>172092 *</b></p> <p><b>Accu-Seal E</b> standard gasket materials, nitrile or silicone seals.</p> <p>—</p> <p>* OEM-style 1-pc gasket, rubberized fiber.</p>								
	172092 *	17200	17204	17203	11106 <i>supersedes</i> 17206	17208	17202	17205	1 Set
	—	7200-10	—	—	1106-10 <i>supersedes</i> 7206-10	7208-10	7202-10	7205-10	Dyno-Pak 10 Sets
<b>1984-89 RWD 20-bolt Aftermarket Oil Pan</b>	 <p><b>172090 *</b></p> <p><b>Accu-Seal E</b> standard gasket materials, nitrile or silicone seals.</p> <p>—</p> <p>* OEM-style 1-pc gasket, rubberized fiber.</p>								
	172090 *	17200	17204	17203	11106 <i>supersedes</i> 17206	17208	17202	17205	1 Set
	—	7200-10	—	—	1106-10 <i>supersedes</i> 7206-10	7208-10	7202-10	7205-10	Dyno-Pak 10 Sets

**NEW!**  
— SEE P. 8 —

**Buick 231 ci V6 · SBBK – Short Block Base Kit**

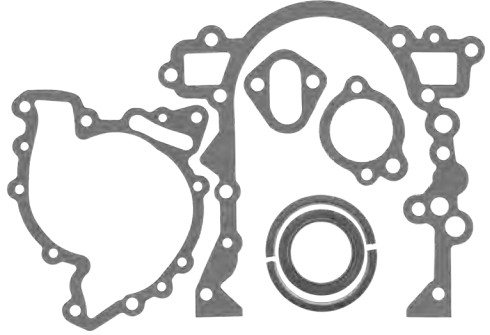
Application	SBBK · Gasket/Oil Seal Kit	Contents of Kit
<b>1975-89 V6 231ci · 3.8L</b>  Fits only rear wheel drive vehicles.	37203	<p><b>Includes:</b></p> <p>Timing Cover · Water Pump · Fuel Pump · Water Outlet Gasket · Timing Cover Seal · 2-pc Silicone Rear Main Seal</p> 

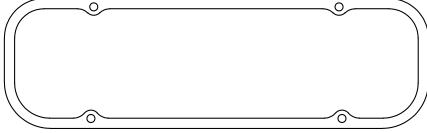

## Buick 231 ci V6 · Valve Cover Gaskets

Application	Molded Silicone Rubber	Hi-Density Cork .187" Thick	Tuff-Bak Laminated Cork		Steel Core PTFE-Coated .093" Thick (3/32")	Qty.
			1/8" Thick	1/4" Thick		
	Street / Strip		Competition / Hi-Vac		Severe Duty™	
1975-89 V6 231 ci 3.8 L	 <p>4-bolt, 2-over-2, perimeter bolt pattern</p>					
		172075	272175	272176	272177	1 Set
		72075-10	72175-10	72176-10	-	Dyno-Pak 10 Sets

## Buick 231 ci V6 · Intake Gaskets

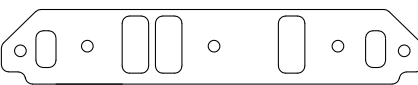
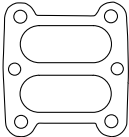
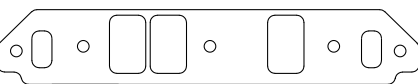
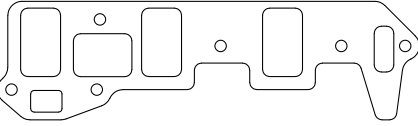
Application — Port Size	Thickness	Accu-Seal E Standard Material		Accu-Seal Pro · Premium Materials	
		Packaged 1 Set	Dyno-Pak · 10 Sets	Packaged 1 Set	Dyno-Pak · 10 Sets
1979-89 Stage 1 231 ci · 3.8 L — 0.90" x 1.97" Rectangle	 <p>Fits Stage 1 Stock Port † Silicone Bead Sealed Ports</p>				
	.062"	172101	72101-10	272101 †	272101-10 †
Idle Air Control	 <p>Fits Idle Air Control Valve · 2 pc.</p>				
	.032"	172106	72106-10	-	-
Stage 1 Modified — 1.24" x 1.96" Rectangle	 <p>Fits Stage 1 Modified Port † Silicone Bead Sealed Ports</p>				
	.062"	172102	72102-10	272102 †	272102-10 †
Stage 2 — 1.42" x 2.42" Rectangle	 <p>Fits Stage 2 Cylinder Heads † Silicone Bead Sealed Ports</p>				
	.062"	172103	72103-10	272103 †	272103-10 †

**Buick 231 ci V6 · Intake Gaskets**

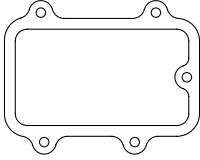
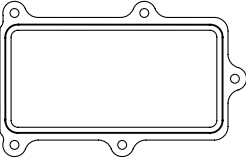
Application — Port Size	Thickness	Accu-Seal E Standard Material		Accu-Seal Pro · Premium Materials	
		Packaged 1 Set	Dyno-Pak · 10 Sets	Packaged 1 Set	Dyno-Pak · 10 Sets
Turbo Plenum		Fits Stock Turbo Manifold Plenum Chamber			
		.062"	172104	72104-10	272104
Champion Plenum		Fits Champion Aluminum Turbo Manifold Plenum Chamber — † Silicone Bead Sealed Perimeter			
		.062"	172105	72105-10	272105 †

**Buick 231ci V6 · Exhaust Gaskets**

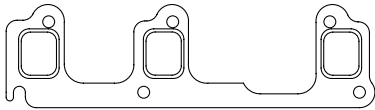
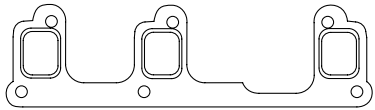
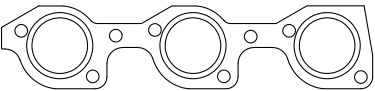
Application — Port Size	Accu-Seal E		Accu-Seal Pro		Graph-Form	Pro-Copper	
	Standard Material .062"		Premium Material .062"		Hi-Density Graphite .150"	Embossed .043"	Flat Annealed .062"
	Packaged 1 Set	Dyno-Pak 10 Sets	Packaged 1 Set	Dyno-Pak 10 Sets	Packaged 1 Set	Packaged 1 Set	Packaged 1 Set
1979-89 Stage 1 Stock Port 231 ci · 3.8 L — 1.07" x 1.50" Rectangle							
	172080	72080-10	272180	72180-10	472180	4472	E72186
Champion Aluminum Head — 1.07" x 1.50" Rectangle							
	—		—		—	4072	—
Stage 2 Oval Port — 1.77" Round							
	172081	72081-10	272181	72181-10	—	4272	—

## Buick 231 ci V6 · Exhaust Gaskets

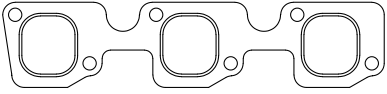
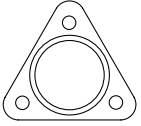
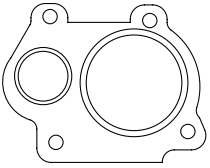
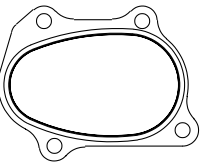
Application — Port Size	Accu-Seal E		Accu-Seal Pro		Graph-Form	Pro-Copper	
	Standard Material .062"		Premium Material .062"		Hi-Density Graphite .150"	Embossed .043"	Flat Annealed .062"
	Packaged 1 Set	Dyno-Pak 10 Sets	Packaged 1 Set	Dyno-Pak 10 Sets	Packaged 1 Set	Packaged 1 Set	Packaged 1 Set
<b>Stage 2 Adapter Gasket</b> — 1.75" Round							
	—		—		—	4372	—
<b>Stage 2</b> — 1.50" x 1.75" Rectangle							
	—		—		—	4572	—
<b>Turbo Flange Gasket</b> — 2.27" Round							
	172082	72082-10	272182	72182-10		4172 1 pc.	—
<b>Turbo Inlet &amp; Wastegate</b> — 4-Bolt, 2-Port							
	—		—		—	4672 1 pc.	—
<b>Turbo to Downpipe</b>							
	—		—		—	4772 1 pc.	—

**Buick 231ci V6 · Accu-Seal Pro · Performance Head Gaskets**

Application	Image	Bore Opening	Compr. Thick.	Part Number	Description	Qty.
1975-88 V6 231 ci 3.8 L		3.980"	.041"	5729841	Composite and steel construction.	1

**\* Buick 231ci V6 · 1975-88 · V6 · 231 ci · 3.8 L**

**Pro-Copper  
Racing Head Gaskets**

For use with o-rings & sealant

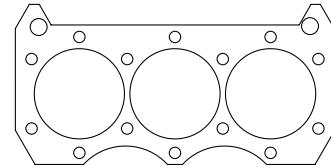
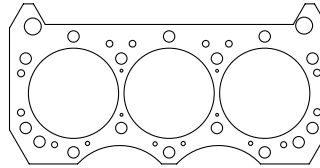

No water holes: use suffix "NW"

Bore Opening	Thickness								Qty.
	.021"	.032"	.043"	.050"	.062"	.072"	.080"	.093"	
3.850" round	P728521	P728532	P728543	P728550	P728562	P728572	P728580	P728593	1
3.950" round	P729521	P729532	P729543	P729550	P729562	P729572	P729580	P729593	1
4.010" round	P720021	P720032	P720043	P720050	P720062	P720072	P720080	P720093	1

**Titan  
Copper Racing Head Gaskets**

Sealed coolant passages, for use with o-rings

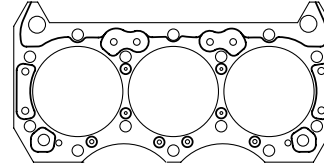

Bore Opening	Thickness								Qty.
	.021"	.032"	.043"	.050"	.062"	.072"	.080"	.093"	
3.850" round	–	T728532	T728543	T728550	T728562	T728572	T728580	T728593	1
3.950" round	–	T729532	T729543	T729550	T729562	T729572	T729580	T729593	1
4.010" round	–	T720032	T720043	T720050	T720062	T720072	T720080	T720093	1

**ICS  
Copper Racing Head Gaskets**

Sealed coolant passages, integral combustion o-ring

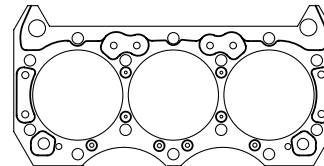

Bore Opening	Thickness								Qty.
	.021"	.032"	.043"	.050"	.062"	.072"	.080"	.093"	
3.950" round	–	–	S729543	S729550	S729562	S729572	S729580	S729593	1
4.010" round	–	–	S720043	S720050	S720062	S720072	S720080	S720093	1

\* **NOTE:** All Buick V6 Copper Racing Head Gaskets are compatible with Stage 1 (8-bolt) & Stage 2 (14-bolt) blocks & heads.

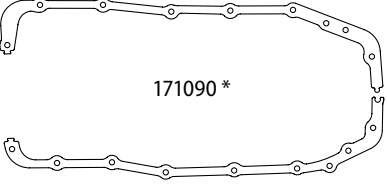

### Buick V8 · Short Block Gaskets & Seals

Application	Oil Pan Gasket Set	Timing Cover Gasket Set	Front Cover Gasket Set TC · WP · FP · Oil Pump	Water Pump Gasket Set	Fuel Pump Gasket	Water Outlet Gasket	Timing Cover Seal	Rear Main Oil Seal	Qty.
1967-76 V8 400, 430, 455 ci 6.6-7.5 L	 <p style="text-align: center;">171090 *</p> <p style="text-align: right;"><b>Accu-Seal E</b> standard gasket materials, nitrile or silicone seals.</p> <p style="text-align: right;">*OEM-style 4-pc set w/ rubberized fiber rails (end seals not pictured).</p>								
	171090 *	17103	17100	17104	11106 <i>supersedes</i> 17106	17108	17102	17105 2-pc	1 Set
	71090-10 *	—	7100-10	—	1106-10 <i>supersedes</i> 7106-10	7108-10	7102-10	7105-10	Dyno-Pak 10 Sets

### Buick V8 · **SBBK** – Short Block Base Kit

Provides remaining gaskets & seals common to the engine type, regardless of customization.

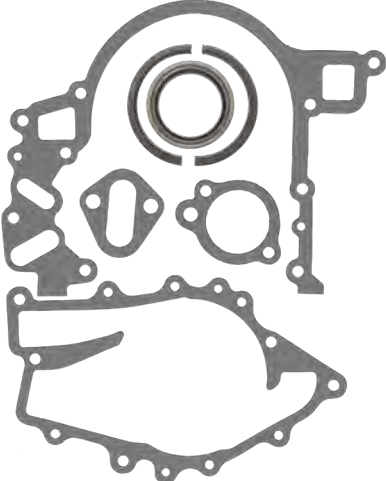

**NEW!**  
— SEE P.8 —

Application	SBBK Gasket/Oil Seal Kit	Contents of Kit
1967-76 V8 400, 430, 455 ci 6.6-7.5 L	37103	<p><b>Includes:</b> Timing Cover · Water Pump · Fuel Pump · Water Outlet Gasket · Timing Cover Seal · 2-pc Silicone Rear Main Seal</p> 

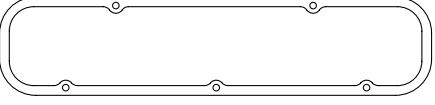

### Buick V8 · Valve Cover Gaskets

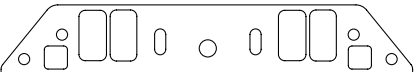
Application	Molded Silicone Rubber	Hi-Density Cork 5/16" Thick	Tuff-Bak Laminated Cork		Steel-Core PTFE-Coated .093" Thick (3/32")	Qty.
	Street / Strip		1/8" Thick	1/4" Thick	Severe Duty™	
1967-76 V8 400, 430, 455 ci 6.6-7.5 L	 <p style="text-align: right;">Also fits Edelbrock Performer RPM Buick and T/A Performance Eliminator heads</p>					
	—	—	271175	271176	271177	1 Set
			71175-10	71176-10	—	Dyno-Pak 10 Sets

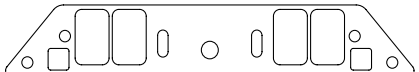
## Buick 400-455 V8 · Intake Gaskets

Application — Port Size	Thickness	Accu-Seal E Standard Material		Accu-Seal Pro · Premium Materials	
		Packaged 1 Set	Dyno-Pak · 10 Sets	Packaged 1 Set	Dyno-Pak · 10 Sets
<b>1967-76</b> <b>Stage 1 / Stock Port</b> <b>400-455 ci · 6.6-7.5 L</b> — <b>1.15" x 2.38"</b> <b>Rectangle</b>	 <p style="text-align: center;">Fits OEM Factory Heads thru Stage 1, also fits Edelbrock Performer RPM. — † Silicone Bead Sealed Ports</p>				
	.062"	171101	71101-10	271101 †	271101-10 †
<b>Racing Derivatives</b>					
<b>Stage 1</b> <b>Modified Port</b> — <b>1.31" x 2.40"</b> <b>Rectangle</b>	 <p style="text-align: center;">Fits TA Performance Aluminum Stage 1 TE</p>				
	.062"	171102	71102-10	271102	271102-10
<b>Stage 2 Head</b> <b>Large Port</b> — <b>1.22" x 2.52"</b> <b>Rectangle</b>	 <p style="text-align: center;">Fits TA Performance Aluminum Stage 2 TE</p>				
	.062"	171104	71104-10	271104	271104-10
<b>Stage 4</b> — <b>1.60" x 2.55"</b> <b>Rectangle</b>	 <p style="text-align: center;">Fits TA Performance Aluminum Stage 4 Tall Port Heads</p>				
	.062"	171103	71103-10	271103	271103-10

**Buick V8 · Exhaust Gaskets · 1967-76 · V8 · 400, 430, 455 ci · 6.6-7.5 L**

Application — Port Size	Accu-Seal E		<i>Accu-Seal Pro</i>		<i>Graph-Form</i>	<i>Pro-Copper</i>	
	Standard Material .062"		Premium Material .062"		Hi-Density Graphite .150"	Embossed .043"	Flat Annealed .062"
	Packaged 1 Set	Dyno-Pak 10 Sets	Packaged 1 Set	Dyno-Pak 10 Sets	Packaged 1 Set	Packaged 1 Set	Packaged 1 Set
Stage 1 Head Stock Port — 1.35" x 2.00" Rectangle					Fits: Edelbrock Performer RPM Buick, TA Performance Stage 1 SE & Stage 1 TE Heads		
	171080	71080-10	271180	71180-10	471180	4071	E71186
Stage 2 Head — 2.00" Round					Fits: TA Performance Aluminum Stage 2 & Stage 4 Tall Port Heads		
	171081	71081-10	271181	71181-10	471181	4171	E71286

**Buick V8 · *Accu-Seal Pro* · Performance Head Gaskets**

Application	Image	Bore Opening	Compr. Thick.	Part Number	Description	Qty.
1967-76 V8 400, 430, 455 ci 6.6-7.5 L		4.390"	.041"	5713941	Composite and steel construction.	1

**Buick V8  
*MLS Spartan* · Performance Head Gaskets**

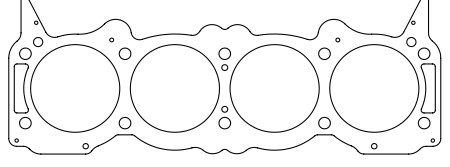
Application	Image	Bore Opening	Compr. Thick.	Part Number	Description	Qty.
1967-69 V8 400, 430 ci 6.6-7.0 L		4.250"	.039"	M712539	MLS embossed stainless steel construction. <b>10-bolt</b>	1
1970-76 V8 455 ci · 7.5 L		4.385"	.039"	M713839		1
<b>Marine Use:</b> stainless steel construction, all MLS Spartan head gaskets are suitable for use in marine applications.						

**\* Buick V8 • 400, 430, 455 ci • 6.6-7.5 L**

**Pro-Copper  
Racing Head Gaskets**

For use with o-rings & sealant

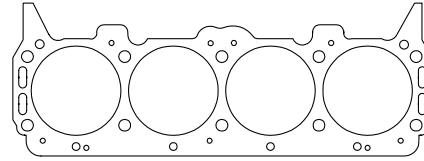

Bore Opening	Thickness								Qty.
	.021"	.032"	.043"	.050"	.062"	.072"	.080"	.093"	
4.160" round	P711521	P711532	P711543	P711550	P711562	P711572	P711580	P711593	1
4.250" round	P712521	P712532	P712543	P712550	P712562	P712572	P712580	P712593	1
4.380" round	P713821	P713832	P713843	P713850	P713862	P713872	P713880	P713893	1

**ICS  
Copper Racing Head Gaskets**

Integral combustion o-ring (no coolant seals)

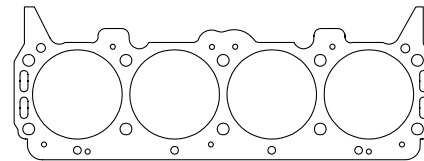

Bore Opening	Thickness								Qty.
	.021"	.032"	.043"	.050"	.062"	.072"	.080"	.093"	
4.160" round	—	—	S711543	S711550	S711562	S711572	S711580	S711593	1
4.250" round	—	—	S712543	S712550	S712562	S712572	S712580	S712593	1
4.380" round	—	—	S713843	S713850	S713862	S713872	S713880	S713893	1

\* **NOTE:** All Buick V8 Copper Racing Head Gaskets are compatible with standard 10-bolt — and 14-bolt (additional exhaust-side head-bolts) configurations.

**Cadillac 472-500, 425 V8 · Short Block Gaskets & Seals**

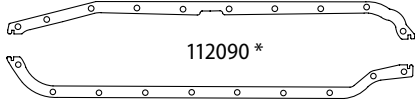
Application	Oil Pan Gasket Set	Timing Cover Gasket Set	Front Cover Gasket Set TC · WP · FP	Water Pump Gasket Set	Fuel Pump Gasket	Water Outlet Gasket	Timing Cover Oil Seal	Rear Main Oil Seal	Qty.
1968-79 V8 425-500 ci 7.0-8.2 L	 <p><b>Accu-Seal E</b> standard gasket materials, nitrile or silicone seals.</p> <p>* OEM-style 4-pc set w/ rubberized fiber rails (end seals not pictured).</p>								
	112090 *	11203	11200	11201	11206	11208	11202	12805 2 Pc.	1 Set
	12090-10 *	—	1200-10	1201-10	1206-10	1208-10	1202-10	2805-10	Dyno-Pak 10 Sets

**Cadillac 472-500, 425 V8 · Valve Cover Gaskets**

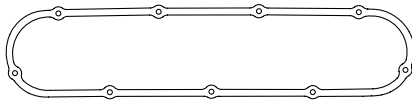
Application	Molded Silicone Rubber	Hi-Density Cork		Tuff-Bak Laminated Cork		Steel-Core PTFE-Coated .093" Thick (3/32")	Qty.	
		3/16" Thick	.5/16" Thick	1/8" Thick	1/4" Thick			
		Street / Strip		Racing / Hi-Vac		Severe Duty™		
1968-79 V8 425-500 ci 7.0-8.2 L	 <p>Stock design 9-bolt (4-over-5) perimeter bolt pattern</p>							
	—	112071	112076	212071	212076	—	1 Set	
	—	12071-10	12076-10	212071-10	212076-10	—	Dyno-Pak 10 Sets	

**Cadillac 472-500, 425 V8 · Intake Gaskets**

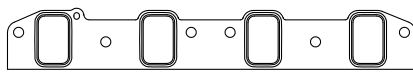
Application — Port Size	Thickness	Accu-Seal E Standard Material		Accu-Seal Pro · Premium Materials	
		Packaged 1 Set	Dyno-Pak · 10 Sets	Packaged 1 Set	Dyno-Pak · 10 Sets
1968-79 · V8 425-500 ci 7.0-8.2 L — 1.37" x 2.19" Rect.	 <p>Stock cylinder head pattern.</p> <p>† Silicone Bead Sealed Ports</p>				
	.062"	112101	12101-10	212101 †	212101-10 †

**Cadillac 472-500, 425 V8 · Exhaust Gaskets**

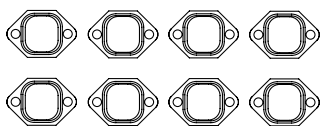
Application — Port Size	Accu-Seal E		Accu-Seal Pro		Graph-Form	Pro-Copper	
	Standard Material .062"		Premium Material .062"		Hi-Density Graphite .150"	Embossed .043"	Flat-Annealed .062"
	Packaged 1 Set	Dyno-Pak 10 Sets	Packaged 1 Set	Dyno-Pak 10 Sets	Packaged 1 Set	Packaged 1 Set	Packaged 1 Set
1968-79 V8 425-500 ci 7.0-8.2 L — 1.63" Rectangle	 <p>Set includes 8 individual pieces.</p>						
	112080 8 pc.	12080-10 80 pc.	212180 8 pc.	12180-10 80 pc.	—	4012 8 pc.	—

**Cadillac 472-500, 425 V8 ·  
Vulcan Cut-Ring · Performance Head Gaskets**

Application	Image	Bore Opening	Compr. Thick.	Part Number	Description	Qty.
1968-79 V8 425-500 ci 7.0-8.2 L		4.380"	.045"	CR123845	Stainless steel Cut-Ring combustion seals.	1
		4.400"		CR124445	Composite gasket body construction.	1

**Cadillac V8 · 472-500, 425 ci · 4.6-6.6 L**

**Pro-Copper Racing Head Gaskets**  
For use with o-rings & sealant

No water holes: use suffix "NW"

Bore Opening	Thickness								Qty.
	.021"	.032"	.043"	.050"	.062"	.072"	.080"	.093"	
4.380" round	P123821	P123832	P123843	P123850	P123862	P123872	P123880	P123893	1
4.440" round	P124421	P124432	P124443	P124450	P124462	P124472	P124480	P124493	1

**Titan Copper Racing Head Gaskets**  
Sealed coolant passages, for use with o-rings & sealant



Bore Opening	Thickness								Qty.
	.021"	.032"	.043"	.050"	.062"	.072"	.080"	.093"	
4.380" round	–	T123832	T123843	T123850	T123862	T123872	T123880	T123893	1
4.440" round	–	T124432	T124443	T124450	T124462	T124472	T124480	T124493	1

**ICS Copper Racing Head Gaskets**  
Sealed coolant passages, integral combustion o-ring

Bore Opening	Thickness								Qty.
	.021"	.032"	.043"	.050"	.062"	.072"	.080"	.093"	
4.380" round	–	–	S123843	S123850	S123862	S123872	S123880	S123893	1
4.440" round	–	–	S124443	S124450	S124462	S124472	S124480	S124493	1

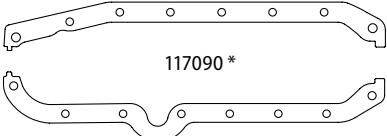

**Chevrolet 90° V6 · Short Block Gaskets & Seals**

Application	Oil Pan Gasket Set	Timing Cover Gasket Set	Front Cover Gasket Set TC · WP · FP	Water Pump Gasket Set	Fuel Pump Gasket	Water Outlet Gasket	Timing Cover Oil Seal	Rear Main Oil Seal	Qty.
1985 V6 262 ci 4.3 L	 <p><b>Accu-Seal E</b> standard gasket materials, nitrile or silicone seals.</p> <p>* OEM-style 4-pc set w/ rubberized fiber rails (end seals not pictured).</p>								
	117090 *	11103	11100	11101	11106 11107 Δ	11108	11102	11105 2 Pc.	1 Set
	17090-10 *	—	1100-10	1101-10	1106-10 1107-10 Δ	1108-10	1102-10	1105-10	Dyno-Pak 10 Sets
	Δ 4-bolt fuel pump block-off plate								
1986-93 V6 262 ci 4.3 L	 <p><b>Accu-Seal Pro</b> premium gasket materials, FKM seals, molded water outlet.</p> <p>† 1-pc molded silicone. Steel backbone &amp; crush limiters.</p>								
	217091 †	TCS 303-5	—	11101	11706	21108	11102	21155	1 Set
	17091-10 †	—	—	1101-10	—	21108-10	1102-10	21155-10	Dyno-Pak 10 Sets

**Chevrolet 90° V6 · SBBK – Short Block Base Kit**

Provides remaining gaskets & seals common to the engine type, regardless of customization.

**NEW!**  
— SEE P. 8 —

Application	SBBK Gasket/Oil Seal Kit	Contents of Kit
1985 V6 262 ci · 4.3 L	31103	<b>Includes:</b> Timing Cover · Water Pump · Fuel Pump · Water Outlet Gasket · Distributor Base Gasket · Timing Cover Seal · 2-pc Silicone Rear Main Seal
	41103	<b>Includes:</b> Timing Cover · Water Pump · Fuel Pump · Water Outlet Gasket · Distributor Base Gasket · Timing Cover Seal · 2-pc FKM Rear Main Seal
1986-93 V6 262 ci · 4.3 L	41155	<b>Includes:</b> Timing Cover · Water Pump · Fuel Pump · Water Outlet Gasket · Distributor Base Gasket · Timing Cover Seal · 1-pc FKM Rear Main Seal

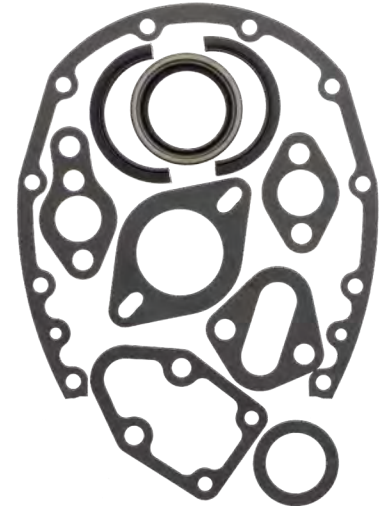

**Chevrolet 90° V6 · Valve Cover Gaskets**

Application	Molded Silicone Rubber	Hi-Density Cork .312" Thick	Tuff-Bak Laminated Cork		Steel Core PTFE-Coated .093" Thick (3/32")	Qty.		
			1/8" Thick	1/4" Thick				
	Street / Strip		Racing / Hi-Vac		Severe Duty™			
1980-Up 90° V6 Marine & Aftermarket Heads 262 ci · 4.3 L			4 perimeter bolts, 2-over-2 aligned					
			-	-	217071	217072	-	1 Set
			-	-	217071-10	217072-10	-	Dyno-Pak 10 Sets
1986-93 90° V6 Stock Head 262 ci · 4.3 L			Center bolts					
			217078	-	217073	217074	-	1 Set
			217078-10	-	217073-10	217074-10	-	Dyno-Pak 10 Sets
Chevrolet Performance 18° High Port Head 90° V6 262 ci · 4.3 L			4 perimeter bolts, 2-over-2 offset, fits NASCAR Busch Series competition heads 1995 & earlier					
			-	-	217075	217076	-	1 Set
			-	-	217075-10	217076-10	-	Dyno-Pak 10 Sets

**Chevrolet 90° V6 · Intake Gaskets**

Application — Port Size	Thickness	Accu-Seal E Standard Material		Accu-Seal Pro · Premium Materials	
		Packaged 1 Set	Dyno-Pak · 10 Sets	Packaged 1 Set	Dyno-Pak · 10 Sets
1980-96 90° V6 262 ci · 4.3 L — 1.10" x 2.20" Rectangle					
	.062"	117101	17101-10	217101	217101-10
Chevrolet Performance 18° High Port Head 90° V6 262 ci · 4.3 L — 1.27" x 2.17" Rectangle					
	.062"	117102	17102-10	217102	217102-10
	.090"	117103	17103-10	-	-
	.120"	117104	17104-10	-	-

**Chevrolet 90° V6 · Exhaust Gaskets**

Application — Port Size	Accu-Seal E		Accu-Seal Pro		Pro-Copper	
	Standard Material .062"		Premium Material .062"		Embossed .043"	Flat-Annealed .062"
	Packaged 1 Set	Dyno-Pak 10 Sets	Packaged 1 Set	Dyno-Pak 10 Sets	Packaged 1 Set	Packaged 1 Set
1980-96 90° V6 Stock Port Head 262 ci · 4.3 L — 1.50" Round			Fits all headers for standard port 90° V6 heads			
	117080	17080-10	217080	217080-10	4017	E17086
1985-96 V6 262 ci · 4.3 L Large Port Head — 1.40" x 1.40" Square			Fits turbo heads/manifolds found in GM SyTy (Syclone & Typhoon) 1991 & later			
	117081	17081-10	217081	217081-10	4117	E17087
Chev. Perform. 18° High Port Head 90° V6 262 ci · 4.3 L — 1.62" Round			Fits all 18° heads including High Port			
	117082	17082-10	217082	217082-10	4217	—

**Chevrolet 90° V6  
Accu-Seal Pro · Performance Head Gaskets**

Application	Image	Bore Opening	Compr. Thick.	Part Number	Description	Qty.
1985-96 90° V6 262 ci · 4.3 L		4.090"	.032"	5170932	Composite & stainless steel construction.	1
			.040"	5170940		1
			.059"	5170959	Suitable for use in marine applications.	1

**Chevrolet 90° V6 • 262 ci • 4.3 L**

**Pro-Copper  
Racing Head Gaskets**

For use with o-rings & sealant

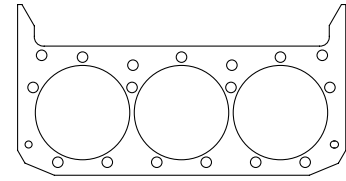
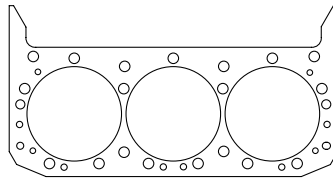

No water holes: use suffix "NW"

Bore Opening	Thickness								Qty.
	.021"	.032"	.043"	.050"	.062"	.072"	.080"	.093"	
4.060" round	P170621	P170632	P170643	P170650	P170662	P170672	P170680	P170693	1
4.160" round	P171521	P171532	P171543	P171550	P171562	P171572	P171580	P171593	1
4.200" round	P172021	P172032	P172043	P172050	P172062	P172072	P172080	P172093	1

**Titan  
Copper Racing Head Gaskets**

Sealed coolant passages, for use with o-rings & sealant

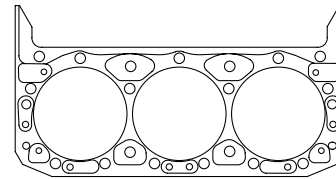

Bore Opening	Thickness								Qty.
	.021"	.032"	.043"	.050"	.062"	.072"	.080"	.093"	
4.060" round	-	T170632	T170643	T170650	T170662	T170672	T170680	T170693	1
4.160" round	-	T171532	T171543	T171550	T171562	T171572	T171580	T171593	1
4.200" round	-	T172032	T172043	T172050	T172062	T172072	T172080	T172093	1

**ICS  
Copper Racing Head Gaskets**

Sealed coolant passages, integral combustion o-ring

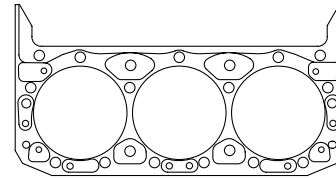

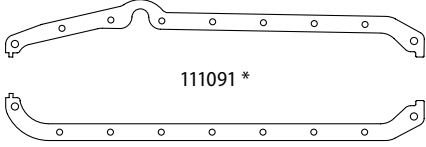
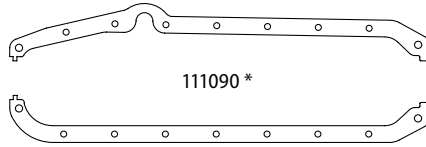

Bore Opening	Thickness								Qty.
	.021"	.032"	.043"	.050"	.062"	.072"	.080"	.093"	
4.060" round	-	-	S170643	S170650	S170662	S170672	S170680	S170693	1
4.160" round	-	-	S171543	S171550	S171562	S171572	S171580	S171593	1
4.200" round	-	-	S172043	S172050	S172062	S172072	S172080	S172093	1

**Chevrolet 262-400 Small Block · Short Block Gaskets & Seals**

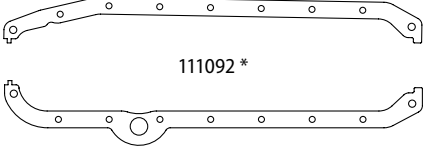

Application	Oil Pan Gasket Set	Timing Cover Gasket Set	Front Cover Gasket Set TC · WP · FP	Water Pump Gasket Set	Fuel Pump Gasket	Water Outlet Gasket	Timing Cover Oil Seal	Rear Main Oil Seal	Qty.
<b>1955-74 GEN I V8 262-400 ci 4.3-6.6 L</b>  Left side oil pan dipstick & .250" (thin) front oil pan seal	 <p style="text-align: center;"><b>111091 *</b></p> <p style="text-align: right;"><b>Accu-Seal E</b> standard gasket materials, nitrile or silicone seals.</p> <p style="text-align: right;">* OEM-style 4-pc set w/ rubberized fiber rails (end seals not pictured).</p>								
	111091 *	11103	11100	11101	11106 11107 Δ	11108	11102	11105 2 Pc.	1 Set
	11091-10 *	—	1100-10	1101-10	1106-10 1107-10 Δ	1108-10	1102-10	1105-10	Dyno-Pak 10 Sets
	Δ 4-bolt fuel pump block-off plate								
	<b>Accu-Seal Pro</b> premium gasket materials, FKM seals, molded water outlet.								
	—	21103	11109 ‡	21101 <i>Steel-Core</i> 2 Pc.	—	21108	21102	21105 2 Pc.	1 Set
	—	1109-10 ‡	21101-10 <i>Steel-Core</i>		21108-10	21102-10	21105-10	Dyno-Pak 10 Sets	
‡ Full-circle quick change front cover									
<b>1975-79 V8 GEN I 350-400 ci 5.7-6.6 L</b>  Left side oil pan dipstick & .400" (thick) front oil pan seal	 <p style="text-align: center;"><b>111090 *</b></p> <p style="text-align: right;"><b>Accu-Seal E</b> standard gasket materials, nitrile or silicone seals.</p> <p style="text-align: right;">* OEM-style 4-pc set w/ rubberized fiber rails (end seals not pictured).</p>								
	111090 *	11103	11100	11101	11106 11107 Δ	11108	11102	11105 2 Pc.	1 Set
	11090-10 *	—	1100-10	1101-10	1106-10 1107-10 Δ	1108-10	1102-10	1105-10	Dyno-Pak 10 Sets
	Δ 4-bolt fuel pump block-off plate								
	<b>Accu-Seal Pro</b> premium gasket materials, FKM seals, molded water outlet.								
		21109 †	—	21109 ‡	—	—	—	—	—
	211090-10 †	—	1109-10 ‡	21101-10 <i>Steel-Core</i>		21108-10	21102-10	21105-10	Dyno-Pak 10 Sets
† 1-pc molded silicone. Steel backbone & crush limiters. ‡ Full-circle quick change front cover									

**Chevrolet 305-400 Small Block · Short Block Gaskets & Seals**

Application	Oil Pan Gasket Set	Timing Cover Gasket Set	Front Cover Gasket Set TC · WP · FP	Water Pump Gasket Set	Fuel Pump Gasket	Water Outlet Gasket	Timing Cover Oil Seal	Rear Main Oil Seal	Qty.	
<b>1980-85 V8 GEN 1 305-350 ci 5.0-5.7 L</b>  Right side oil pan dipstick & .400" (thick) front oil pan seal	 <p>111092 *</p>		<p><b>Accu-Seal E</b> standard gasket materials, nitrile or silicone seals.</p> <p>* OEM-style 4-pc set w/ rubberized fiber rails (end seals not pictured).</p>							
	111092 *	11103	11100	11101	11106 11107 Δ	11108	11102	11105 2 Pc.	1 Set	
	11092-10 *	—	1100-10	1101-10	1106-10 1107-10 Δ	1108-10	1102-10	1105-10	Dyno-Pak 10 Sets	
	Δ 4-bolt fuel pump block-off plate									
	 <p>211090 †</p>		<p><b>Accu-Seal Pro</b> premium gasket materials, FKM seals, molded water outlet.</p> <p>† 1-pc molded silicone. Steel backbone &amp; crush limiters.</p>							
211090 †	21103	11109 ‡	21101 Steel-Core 2 Pc.	—	21108	21102	21105 2 Pc.	1 Set		
211090-10 †	—	1109-10 ‡	21101-10 Steel-Core	—	21108-10	21102-10	21105-10	Dyno-Pak 10 Sets		
‡ Full-circle quick change front cover										
<b>1986-97 V8 GEN 1 &amp; 2 305-350 ci 5.0-5.7 L incl. Crate Engine</b>  Right side oil pan dipstick & .400" (thick) front oil pan seal, 1-pc rear main seal	<p><b>Accu-Seal E</b> standard gasket materials, nitrile or silicone seals.</p>									
	—	11103	11100 ◊	11101 ◊	11106 11107 Δ	11108	11102	—	1 Set	
	—	—	1100-10 ◊	1101-10 ◊	1106-10 1107-10 Δ	1108-10	1102-10	—	Dyno-Pak 10 Sets	
	Δ 4-bolt fuel pump block-off plate • ◊ GEN 1 only									
	 <p>211092 †</p>		<p><b>Accu-Seal Pro</b> premium gasket materials, FKM seals, molded water outlet.</p> <p>† 1-pc molded silicone. Steel backbone &amp; crush limiters.</p>							
211092 †	21103	11109 ‡ ◊	21101 ◊ Steel-Core 2 Pc.	—	21108	21102	21155 1 Pc.	1 Set		
211092-10 †	—	1109-10 ‡ ◊	21101-10 ◊ Steel-Core	—	21108-10	21102-10	21155-10	Dyno-Pak 10 Sets		
‡ Fits full-circle quick change front cover • ◊ GEN 1 only										

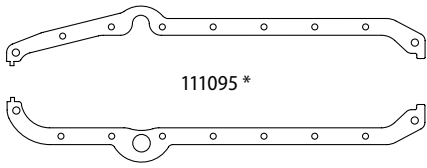

**Chevrolet 350-400 Small Block · Short Block Gaskets & Seals**

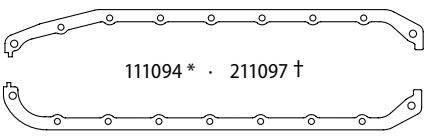
Application	Oil Pan Gasket Set	Timing Cover Gasket Set	Front Cover Gasket Set TC · WP · FP	Water Pump Gasket Set	Fuel Pump Gasket	Water Outlet Gasket	Timing Cover Oil Seal	Rear Main Oil Seal	Qty.	
<b>GEN 1 SBC GM Target- master Crate Engine 350 ci 5.7 L</b>  Right & left oil pan dipstick with 2-pc rear main seal	 <p>111095 *</p>		<p><b>Accu-Seal E</b> standard gasket materials, nitrile or silicone seals.</p> <p>—</p> <p>* OEM-style 4-pc set w/ rubberized fiber rails (end seals not pictured).</p>							
	111095 *	11103	11100	11101	11106 11107 Δ	11108	11102	11105 2 Pc.	1 Set	
	11095-10 *	—	1100-10	1011-10	1106-10 1107-10 Δ	1108-10	1102-10	1105-10	Dyno-Pak 10 Sets	
	Δ 4-bolt fuel pump block-off plate									
	 <p>211090 †</p>		<p><b>Accu-Seal Pro</b> premium gasket materials, FKM seals, molded water outlet.</p> <p>—</p> <p>† 1-pc molded silicone. Steel backbone &amp; crush limiters.</p>							
	211090 †	21103	11109 ‡	21101 Steel-Core 2 Pc.	—	21108	21102	21105 2 Pc.	1 Set	
	211090-10 †	—	1109-10 ‡	21101-10 Steel-Core	—	21108-10	21102-10	21105-10	Dyno-Pak 10 Sets	
	‡ Full-circle quick change front cover									
	<b>SBC Racing Derivatives</b>									
	<b>GEN 1 SBC CNC Bowtie · Donovan 350</b>	 <p>111094 * · 211097 †</p>		<p><b>Accu-Seal E</b> standard gasket materials, nitrile or silicone seals.</p> <p>—</p> <p>* 4-pc set w/ rubberized fiber rails (end seals not pictured). Straight rail oil pan gasket trimmed for rod clearance, no dipstick.</p>						
111094 *		11103	11100	11101	11106 11107 Δ	11108	11102	11105 2 Pc.	1 Set	
11094-10 *		—	1100-10	1011-10	1106-10 1107-10 Δ	1108-10	1102-10	1105-10	Dyno-Pak 10 Sets	
Δ 4-bolt fuel pump block-off plate										
<p><b>Accu-Seal Pro</b> premium gasket materials, FKM seals, molded water outlet.</p> <p>—</p> <p>† 4-pc set · Severe Duty™, .093" thick PTFE-coated, steel-core material. Straight rail oil pan gasket trimmed for rod clearance, no dipstick.</p>										
211097 †		21103	—	21101 Steel-Core 2 Pc.	—	21108	21102	21105 2 Pc.	1 Set	
211097-10 †	—	—	21101-10 Steel-Core	—	21108-10	21102-10	21105-10	Dyno-Pak 10 Sets		

**SBC Racing Derivatives · Short Block Gaskets & Seals**

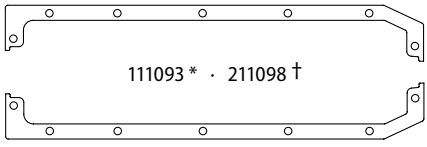
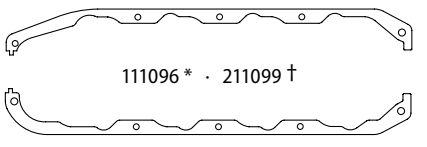
Application	Oil Pan Gasket Set	Timing Cover Gasket Set	Front Cover Gasket Set TC · WP · FP	Water Pump Gasket Set	Fuel Pump Gasket	Water Outlet Gasket	Timing Cover Oil Seal	Rear Main Oil Seal	Qty.	
<b>GEN 1 SBC Chevrolet Performance Rocket Block · CN Blocks 2040, 2041, 2045, 2046 Splay Cap SBC</b>	 <p>111093 * · 211098 †</p> <p><b>Accu-Seal E</b> standard gasket materials, nitrile or silicone seals.</p> <p>* 4-pc set w/ rubberized fiber rails (end seals not pictured). Straight rail oil pan, no dipstick.</p>									
	111093 *	11103	11100	11101	11106 11107 Δ	11108	11102	11105 2 Pc.	1 Set	
	11093-10 *	—	1100-10	1011-10	1106-10 1107-10 Δ	1108-10	1102-10	1105-10	Dyno-Pak 10 Sets	
	Δ 4-bolt fuel pump block-off plate									
	<p><b>Accu-Seal Pro</b> premium gasket materials, FKM seals, molded water outlet.</p> <p>† 4-pc set · Severe Duty™, .093" thick PTFE-coated, steel-core material. · Straight rail oil pan, no dipstick.</p>									
	211098 †	21103	11109 ‡	21101 Steel-Core 2 Pc.	—	21108	21102	21105 2 Pc.	1 Set	
	211098-10 †	—	1109-10 ‡	21101-10 Steel-Core	—	21108-10	21102-10	21105-10	Dyno-Pak 10 Sets	
	‡ Full-circle quick-change front cover									
	<b>GEN 1 SBC Donovan 410 High Cam</b>	 <p>111096 * · 211099 †</p> <p><b>Accu-Seal E</b> standard gasket materials, nitrile or silicone seals.</p> <p>* 4-pc set w/ rubberized fiber rails (end seals not pictured). Straight rail oil pan, no dipstick.</p>								
		111096 *	11103	11100HC	11101	11106 11107 Δ	11108	11102	11105 2 Pc.	1 Set
111096-10 *		—	1100HC-10	1011-10	1106-10 1107-10 Δ	1108-10	1102-10	1105-10	Dyno-Pak 10 Sets	
Δ 4-bolt fuel pump block-off plate										
<p><b>Accu-Seal Pro</b> premium gasket materials, FKM seals, molded water outlet.</p> <p>† 4-pc set · Severe Duty™, .093" thick PTFE-coated, steel-core material. · Straight rail oil pan, no dipstick.</p>										
211099 †		21103	11109 ‡	21101 Steel-Core 2 Pc.	—	21108	21102	21105 2 Pc.	1 Set	
211099-10 †		—	1109-10 ‡	21101-10 Steel-Core	—	21108-10	21102-10	21105-10	Dyno-Pak 10 Sets	
‡ Full-circle quick-change front cover										

**SBC Racing Derivatives · Short Block Gaskets & Seals**

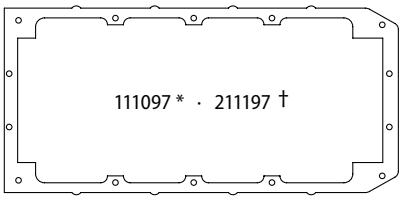
Application	Oil Pan Gasket Set	Timing Cover Gasket Set	Water Pump Gasket Set	Fuel Pump Gasket	Water Outlet Gasket	Timing Cover Oil Seal	Rear Main Oil Seal	Qty.
<b>CN Blocks 2010Y Cross-Bolt Wide Rail SBC</b>	 <p>111097 * · 211197 †</p> <p><b>Accu-Seal E</b> standard gasket materials, nitrile or silicone seals.</p> <p>* Rubberized fiber. • 1-pc oil pan, no dipstick.</p>							
	111097 *	11109 ‡	-	-	-	-	11105 2 Pc.	1 Set
	111097-10 *	1109-10 ‡	-	-	-	-	1105-10	Dyno-Pak 10 Sets
	‡ Fits full-circle quick-change front cover							
	<p><b>Accu-Seal Pro</b> premium gasket materials, FKM seals, molded water outlet.</p> <p>† Severe Duty™, .093" thick PTFE-coated, steel-core material. • 1-pc oil pan, no dipstick.</p>							
	211197 †	-	-	-	-	-	21105 2 Pc.	1 Set
211197-10 †	-	-	-	-	-	21105-10	Dyno-Pak 10 Sets	

**SBC 262-400 · SBBK – Short Block Base Kit**



Provides remaining gaskets & seals common to the engine type, regardless of customization.

**NEW!**  
— SEE P.8 —

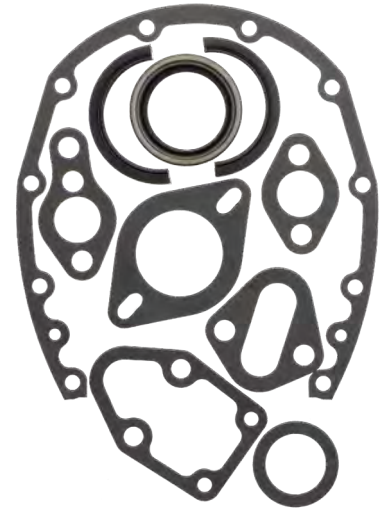
Application	SBBK Gasket/Oil Seal Kit	Contents of Kit
<b>1958-91 V8 · Gen 1 262-400 ci · 4.3-6.6 L</b>	31103	<b>Includes:</b> Timing Cover · Water Pump · Fuel Pump · Water Outlet Gasket · Distributor Base Gasket · Timing Cover Seal · 2-pc Silicone Rear Main Seal
	41103	<b>Includes:</b> Timing Cover · Water Pump · Fuel Pump · Water Outlet Gasket · Distributor Base Gasket · Timing Cover Seal · 2-pc FKM Rear Main Seal
<b>1970-76 V8 · Gen 1 400 ci · 6.6 L</b>	41104	<b>Includes:</b> Timing Cover · Water Pump · Fuel Pump · Water Outlet Gasket · Distributor Base Gasket · Timing Cover Seal · 2-pc FKM Rear Main Seal for Large O.D. Align-honed 400 Engine
<b>1986-95 V8 · Gen 1 305-350 ci · 5.0-5.7 L</b>	41155	<b>Includes:</b> Timing Cover · Water Pump · Fuel Pump · Water Outlet Gasket · Distributor Base Gasket · Timing Cover Seal · 1-pc FKM Rear Main Seal



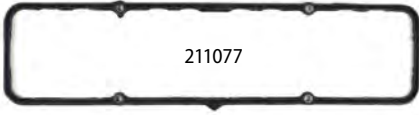

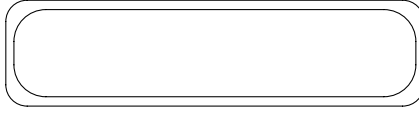
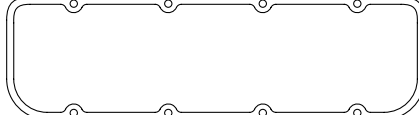
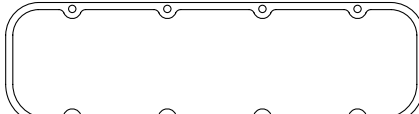
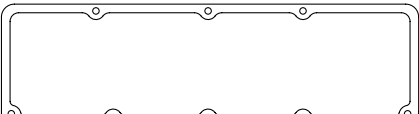
**Chevrolet 283-400 Small Block · Valve Cover Gaskets**

Application	Molded Silicone Rubber	Hi-Density Cork .187" Thick	Hi-Density Cork 5/16" Thick	Tuff-Bak Laminated Cork		Steel Core PTFE-Coated .093" Thick (3/32")	Qty.
				1/8" Thick	1/4" Thick		
	Street / Strip			Racing / Hi-Vac		Severe Duty™	
1958-85 V8 GEN 1 283-400 ci 4.3-6.6 L	 <p>211077</p>			23° Head-Stock Design 4-bolt (2-over-2) perimeter bolt pattern			
	211077	111075	111076	211075	211076	211173	1 Set
	211077-10	11075-10	11076-10	211075-10	211076-10	—	Dyno-Pak 10 Sets
12° & 18° SBC Heads				4-bolt, 2-over-2, perimeter bolt pattern with notches for rocker tips & valve springs			
	—	—	—	211071	211073	211178	1 Set
	—	—	—	211071-10	211073-10	211178-10	Dyno-Pak 10 Sets
1986-97 V8 GEN 1 & 2 305-350 ci 5.0-5.7 L				23° Head-Stock Design 4-center-bolt (linear) pattern			
	211179	—	—	211078	211079	211278	1 Set
	211179-10	—	—	211078-10	211079-10	—	Dyno-Pak 10 Sets
Chevrolet Performance SB2.2 "Mirror Port"				8-bolt non-symmetrical, 4 over 4 pattern			
	—	—	—	211072	211172	211273	1 Set
	—	—	—	211072-10	211172-10	211273-10	Dyno-Pak 10 Sets
Chevrolet Performance Played Valve Cylinder Head				8-bolt symmetrical, 4-over-4 pattern			
	—	—	—	211074	211174	211275	1 Set
	—	—	—	211074-10	211174-10	211275-10	Dyno-Pak 10 Sets
Dart-Buick SBC				8-bolt, 3 over 5 pattern Buick valve covers			
	—	—	—	211275	211276	—	1 Set
	—	—	—	211275-10	211276-10	—	Dyno-Pak 10 Sets

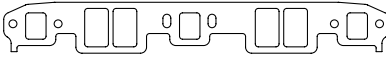
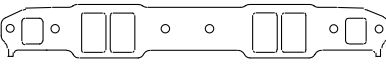
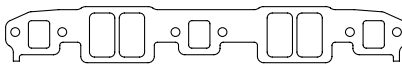
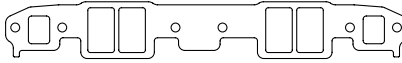
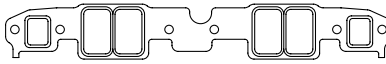
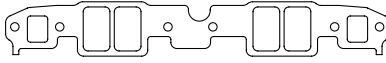
**Chevrolet 262-400 Small Block · Intake Gaskets**

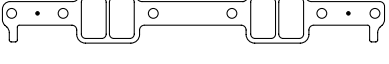

Application — Port Size	Thickness	Accu-Seal E Standard Material		Accu-Seal Pro · Premium Materials	
		Packaged 1 Set	Dyno-Pak · 10 Sets	Packaged 1 Set	Dyno-Pak · 10 Sets
<b>1955-91 GEN 1 · V8 262-400 ci 4.3-6.6 L</b> — <b>1.20" x 2.01" Rectangle</b>	 <p>23° Head Stock Port. Also fits Brodix 1K, RR180, RR200 Edelbrock E-Street &amp; Performer. — † Silicone Bead Sealed Ports</p>				
	.062"	111101	11101-10	211101 †	211101-10 †
	.120"	111106	11106-10	—	
<b>23° Head Small Race Port GEN 1 · V8 262-400 ci 4.3-6.6 L</b> — <b>1.28" x 2.09" Rectangle</b>	 <p>Also fits Dart Pro-1 180, 200, Brodix Track 1, Edelbrock Performer RPM, &amp; similar. — † Silicone Bead Sealed Ports</p>				
	.062"	111138	11138-10	211138 †	211138-10 †
	.120"	111139	11139-10	—	
<b>23° Head Medium Race Port GEN 1 SBC</b> — <b>1.25" x 2.20" Rectangle</b>	 <p>Fits Dart Pro-1 215, Brodix Track 1, Edelbrock Performer RPM, &amp; similar. — † Silicone Bead Sealed Ports</p>				
	.062"	111102	11102-10	211102 †	211102-10 †
	.120"	111103	11103-10	—	
<b>ASCS 23° Head Medium Race Port GEN 1 SBC</b> — <b>1.31" x 2.21" Rectangle</b>	 <p>ASCS 360ci Sprint Car Series Spec Intake. Also fits Dart Pro-1 215, Brodix Track 1, Edelbrock Performer RPM, &amp; similar. — † Silicone Bead Sealed Ports</p>				
	.062"	111141	11141-10	211141 †	211141-10 †
	.120"	111142	11142-10	—	
<b>23° Head Large Race Port with Center Flow Coolant GEN 1 SBC</b> — <b>1.30" x 2.25" Rectangle</b>	 <p>Also fits Dart Pro-1 227; Brodix DS225, -8, -10, -11, 11X, &amp; similar. — † Silicone Bead Sealed Ports</p>				
	.062"	111128	11128-10	211128 †	211128-10 †
	.120"	—		—	
<b>Extra Large Race Port With Center Flow Coolant GEN 1 SBC</b> — <b>1.38" x 2.30" Rectangle</b>	 <p>Also fits Brodix -12 Series 15° heads &amp; similar. — † Silicone Bead Sealed Ports</p>				
	.062"	111107	11107-10	211107 †	211107-10 †
	.120"	111113	11113-10	—	

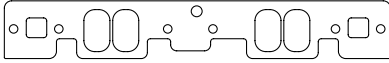
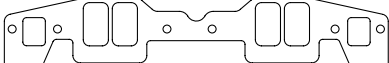
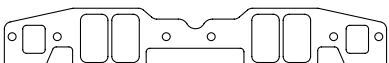
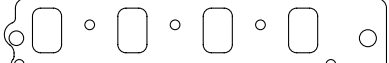
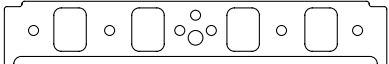
**Chevrolet 262-400 Small Block · Intake Gaskets**



Application — Port Size	Thickness	Accu-Seal E Standard Material		Accu-Seal Pro · Premium Materials	
		Packaged 1 Set	Dyno-Pak · 10 Sets	Packaged 1 Set	Dyno-Pak · 10 Sets
<b>GEN 1 SBC w/ Vortec or Fast Burn Heads</b> — <b>2.10" Tapered Rectangle</b>		Fits Chevrolet Performance Vortec Head & 23° Fast Burn Cylinder Heads — † Silicone Bead Sealed Ports			
		.062"	111119	11119-10	211119 †
	.120"	111120	11120-10	211120 †	211120-10 †
<b>1992-97 LT1 GEN 2 SBC 350 ci · 5.7 L</b> — <b>1.29" x 2.11" Rectangle</b>		Fits Gen 2 LT-1 & LT-4 Reverse Flow heads with rectangle ports. — Perforated Metal-Core Graphite			
		.062"	—	—	211116
<b>1992-97 V8 · GEN 2 350 ci · 5.7 L</b> — <b>2.25" Tapered Rectangle</b>		Fits Gen 2 LT-1 & LT-4 Reverse Flow heads with tapered rectangle ports. — Silicone Bead Sealed Ports			
		.062"	—	—	211127
<b>Racing Derivatives</b>					
<b>Copper Distributor/ Magneto Shims</b>		<ul style="list-style-type: none"> <li>• Allows optimization of distributor gear &amp; camshaft gear interface.</li> <li>• Allows adjustment of distributor to oil pump drive shaft clearance.</li> <li>• Improves distributor/magneto grounding.</li> </ul>			
		.010"	—	—	202C
<b>Brodix Head Hunter™ Heads</b> — <b>1.33" x 2.17" Rectangle</b>		Fits Brodix 23° Head Hunter™ with 229 or 234cc runners			
		.062"	111135	11135-10	211135
<b>Brodix 12 Series, 15° Heads</b> — <b>1.30" x 2.20" Rectangle</b>		Fits Brodix 12 Series, 15° Heads			
		.062"	111125	11125-10	211125
<b>Brodix 12 Series Ported Heads</b> — <b>1.41" x 2.50" Rectangle</b>		Fits Brodix 12 Series CNC Ported Heads			
		.062"	111126	11126-10	211126
<b>Brodix 1010, 2000, 2300 Heads</b> — <b>1.50" x 2.30" Rectangle</b>		Fits Brodix BD 1010, BD 2000, BD 2300, 12° & 13.5° Symmetrical Port Heads			
		.062"	111137	11137-10	211137
<b>Brodix 14° Canted Valve Heads</b> — <b>1.50" x 2.30" Rectangle</b>		Fits Brodix 14° Canted Valve High Port Heads			
		.062"	111130	11130-10	211130

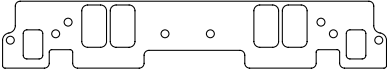
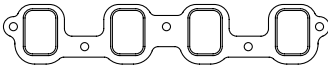

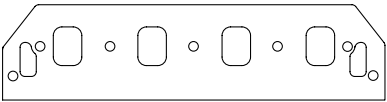
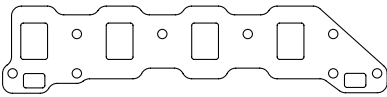
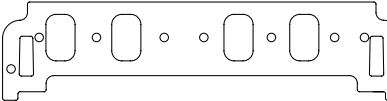
**SBC Racing Derivatives · Intake Gaskets**

Application — Port Size	Thickness	Accu-Seal E Standard Material		Accu-Seal Pro · Premium Materials	
		Packaged 1 Set	Dyno-Pak · 10 Sets	Packaged 1 Set	Dyno-Pak · 10 Sets
<b>Chev. Perform. 18° High Port Cylinder Heads</b> — <b>1.26" x 2.18" Rectangle</b>	 <p>Fits Chevrolet Performance 18° High Port &amp; Brodix 18C — † Silicone Bead Sealed Ports</p>				
	.062"	111118	11118-10	211118 †	211118-10 †
<b>Chev. Perform. SB2 Cylinder Heads</b> — <b>1.40" x 1.90" Rectangle</b>	 <p>Fits SB2/SB2.2 Intake Spider — † Silicone Bead Sealed Ports</p>				
	.062"	111114	11114-10	211114 †	211114-10 †
	 <p>Fits SB2/SB2.2 Valley Cover — † Silicone Bead Sealed Ports</p>				
.062"	111115	11115-10	211115 †	211115-10 †	
<b>Chev. Perform. Splayed-Valve Heads</b> — <b>1.50" x 2.00" Rectangle</b>	 <p>Fits Chevrolet Performance Symmetrical Port Splayed Valve Heads</p>				
	.062"	111104	11104-10	211104	211104-10
	.120"	111105	11105-10	211105	211105-10
<b>Dart-Buick Cylinder Heads</b> — <b>Trim-to-Fit thru 1.60" x 2.90" Rectangle</b>	 <p>Trim-to-fit ports, Stage II Buick V6 intake port design, requires special valve cover &amp; exhaust gaskets — † Silicone Bead Sealed Ports</p>				
	.062"	111129	11129-10	211129 †	211129-10 †
<b>Dart Little Chief Heads</b> — <b>1.44" x 2.30" Rectangle</b>	 <p>Fits Dart Little Chief — † Silicone Bead Sealed Ports</p>				
	.062"	111136	11136-10	211136 †	211136-10 †

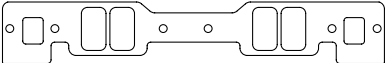
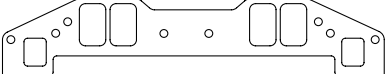
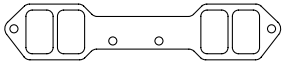
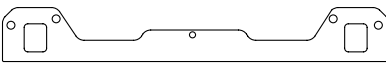
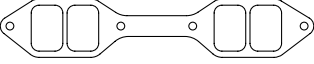
**SBC Racing Derivatives · Intake Gaskets**

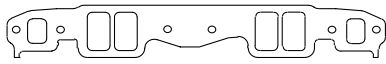
Application — Port Size	Thickness	Accu-Seal E Standard Material		Accu-Seal Pro · Premium Materials	
		Packaged 1 Set	Dyno-Pak · 10 Sets	Packaged 1 Set	Dyno-Pak · 10 Sets
RHS 23° Heads — 1.26" x 2.19" Rectangle	 <p>Also fits Pro Action/Pro Topline 23° Head</p>				
	.062"	111123	11123-10	211123	211123-10
RHS 14° Heads — 1.36" x 2.19" Rectangle	 <p>Also fits Pro Topline 14° Head</p>				
	.062"	111124	11124-10	211124	211124-10
RHS 14° Heads & 2 pc manifold — 1.36" x 2.19" Rectangle	 <p>Also fits Pro Topline 14° Head &amp; 2 Piece Intake. Spider set includes 4 gaskets for use with phenolic spacers.</p>				
	.062"	111122	11122-10	211122	211122-10
	 <p>Fits 14° Valley Cover</p>				
	.062"	111121	11121-10	211121	211121-10
RHS 12° Heads & 2 pc manifold — 1.52" x 2.10" Rectangle	 <p>Also fits Pro Topline 12° Head &amp; 2 Piece Intake. Spider set includes 4 gaskets for use with phenolic spacers.</p>				
	.062"	111131	11131-10	211131	211131-10
	 <p>Fits 12° Valley Cover</p>				
	.062"	111132	11132-10	211132	211132-10
RHS 223 Heads — 1.19" x 2.05" Rectangle	 <p>Fits RHS/Pro Topline 223, 4000, 80A Cylinder Heads</p>				
	.062"	111133	11133-10	211133	211133-10

**Chevrolet 262-400 Small Block - Exhaust Gaskets**

Application — Port Size	Accu-Seal E		Accu-Seal Pro		Graph-Form	Steel-Clad	Pro-Copper	
	Standard Material .062"		Premium Material .062"		Hi-Density Graphite .150"	Steel Back .083"	Embossed .043"	Flat-Annealed .062"
	Packaged 1 Set	Dyno-Pak 10 Sets	Packaged 1 Set	Dyno-Pak 10 Sets	Packaged 1 Set	Packaged 1 Set	Packaged 1 Set	Packaged 1 Set
<b>1955-91 V8 · GEN 1 262-400ci 4.3-6.6L</b> — <b>1.63" Round</b>			Up to 1.625" O.D. round port headers and stock rounded port cast iron manifolds					
<b>GEN 1 SBC w/ Square Exhaust Ports</b> — <b>1.45" x 1.44" Square</b>			Square port headers, 400ci truck square port cast iron manifolds & modified medium race port heads.					
<b>GEN 1-2 SBC w/ Oval Port Headers</b> — <b>1.35" x 1.70" Oval</b>			Dynomax®, Hooker® Super Comp & similar oval port headers with stock 6-bolt pattern					
<b>GEN 1-2 SBC 602 Crate 350 ci · 5.7 L</b> — <b>1.45" x 1.44" Square</b>			Fits: GM CT350 602 Crate Engines. Raised port location with standard bolt pattern.					
<b>GEN 1-2 SBC 604 CRATE 350 ci · 5.7 L</b> — <b>1.45" x 1.37" D-Port</b>			Fits: GEN 1 ZZ6 · GEN 2 LT-1, LT-4 · GM 604 Crate Engines. Use with stock manifolds or similar D-Port headers; gasket matches cylinder head port shape.					
<b>1992-97 V8 · GEN 2 350 ci · 5.7 L</b> — <b>1.48" x 1.44" Square</b>			Fits only Air Flow Research LT1/LT4					
<b>GEN 1 SBC w/ D-Port Headers</b> — <b>1.50" x 1.67" D-Port</b>			Fits Edelbrock Performer, Brodix Track 1, & similar D-Port heads with stock 6-bolt pattern					
<b>GEN 1 SBC w/ Header Adapter Plate</b> — <b>1.35" x 1.70" Rectangle</b>			Hooker® style adapter plate. Gaskets have dual-bolt pattern for use between header & adapter or adapter & head.					

**SBC Racing Derivatives · Exhaust Gaskets**

Application — Port Size	Accu-Seal E		Accu-Seal Pro		Graph-Form	Steel-Clad	Pro-Copper	
	Standard Material .062"		Premium Material .062"		Hi-Density Graphite .150"	Steel Back .083"	Embossed .043"	Flat-Annealed .062"
	Packaged 1 Set	Dyno-Pak 10 Sets	Packaged 1 Set	Dyno-Pak 10 Sets	Packaged 1 Set	Packaged 1 Set	Packaged 1 Set	Packaged 1 Set
<b>AJPE Billet Small Block TF Heads</b> — <b>1.97" x 1.76" Oval</b>					Fits AJPE Billet Small Block TF Head. Individual gaskets, 2 bolts each port. Set includes 8 individual pieces.			
	111289 8 pc.	11289-10 80 pc.	211289 8 pc.	211289-10 80 pc.	—	—	—	—
<b>ASCS 410 12° High Port Heads</b> — <b>1.75" x 1.62" D-Port</b>					AJPE, All Pro, Brodix 12°, "ASCS 410 ci" Heads, 12° & 13° sprint heads with raised ports, 7-bolt pattern for use with 2" headers			
	111083	11083-10	211183	11183-10	411183	711183	4411	E11386
<b>ASCS 360 12° High Port Heads</b> — <b>1.80" x 1.70" D-Port</b>					AJPE, All Pro, Brodix 12°, "ASCS 360 ci" Heads, 12° & 13° sprint heads with raised ports, 7-bolt pattern for use with 2" headers			
	111288	111288-10	211288	211288-10	—	711288	—	—
<b>Brodix Spread Port 18° Heads</b> — <b>1.875" Round</b>					Brodix Spread Port 18° Head, 7 bolt pattern fits Lemons and similar 2" headers			
	111283	11283-10	211283	211283-10	—	—	—	E11686
<b>Brodix 1010, 2000, 2300 Heads</b> — <b>2.020" Round</b>					Fits Brodix BD 1010, BD 2000, BD 2300, 12° & 13.5° Symmetrical Port Heads			
	—	—	—	—	—	—	4911	4911-2
<b>Chev. Perf. 18° High Port Heads</b> — <b>1.74" x 1.60" Square</b>					Fits Chevrolet Performance 18°, Brodix 18C, & RHS small block heads with GM 18° 6-bolt pattern			
	111089	11089-10	211189	11189-10	411189	—	4111	E11986
<b>Chev. Perf. SB2 Heads</b> — <b>1.80" x 1.60" Square</b>					Fits Chevrolet Performance SB2/SB2.2 Mirror Port Head 8-bolt pattern, rounded rectangle opening matches cylinder head port shape			
	111085	11085-10	211185	11185-10	411185	—	4811	—
<b>Chev. Perf. Splayed-Valve Heads</b> — <b>1.875" Round</b>					Fits only Chevrolet Performance Splayed Valve Head 2" headers, 2 bolts per port @ 45° angle			
	111284	11284-10	211284	211284-10	—	—	—	—

**SBC Racing Derivatives - Exhaust Gaskets**

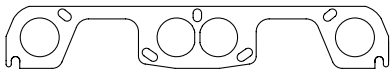
Application — Port Size	Accu-Seal E		<i>Accu-Seal Pro</i>		<i>Graph-Form</i>	Steel-Clad	<i>Pro-Copper</i>	
	Standard Material .062"		Premium Material .062"		Hi-Density Graphite .150"	Steel Back .083"	Embossed .043"	Flat-Annealed .062"
	Packaged 1 Set	Dyno-Pak 10 Sets	Packaged 1 Set	Dyno-Pak 10 Sets	Packaged 1 Set	Packaged 1 Set	Packaged 1 Set	Packaged 1 Set
Dart-Buick Heads — 1.59" x 1.56" Square	 <p>Fits only Dart-Buick SBC heads with 8-bolt pattern</p>							
	111286	11286-10	211286	211286-10	—	—	—	—
Hooker®/ Stahl® Headers — 1.875" Round	 <p>Hooker®/Stahl® Combination. 7-bolt pattern, slotted bolt holes, outer ports round, inner ports have flats along center, for use with 2" headers.</p>							
	111285	11285-10	211285	211285-10	—	—	—	E11486

**Chevrolet 262-400 Small Block**  
**Accu-Seal Pro · Performance Head Gaskets**

Application	Image	Bore Opening	Compr. Thick.	Part Number	Description	Qty.			
<b>1957-91</b> <b>V8</b> <b>GEN 1</b> <b>283-350 ci</b> <b>4.6-5.7 L</b>		4.093"	.032"	5110932	Composite & stainless steel construction.  Suitable for use in marine applications.	1			
				5110932-10		Dyno-Pak 10 pc.			
				5110932B		Hundred-Pak 100 pc.			
			.043"	5110943		1			
				5110943-10		Dyno-Pak 10 pc.			
				5110943B		Hundred-Pak 100 pc.			
			.059"	5110959		1			
				5110959-10		Dyno-Pak 10 pc.			
				5110959B		Hundred-Pak 100 pc.			
				3.960"		.020"	5119620	Embossed steel shim construction.	1
				4.090"			5110920		1
				4.140"			5111420		1
				4.165"			5111620		1
	4.140"	.021"	5111521	Embossed copper shim construction.	1				
<b>1992-97</b> <b>V8</b> <b>GEN 2</b> <b>LT1/LT4</b> <b>350 ci</b> <b>5.7 L</b>		4.140"	.040"	5111540LT	Composite and steel construction.	1			



**Chevrolet 302-400 Small Block**  
**MLS Spartan · Performance Head Gaskets**

Application	Image	Bore Opening	Compr. Thick.	Part Number	Description	Qty.
<b>1964-91</b> <b>V8</b> <b>GEN 1</b> <b>302, 327, 350 ci</b> <b>5.0-5.7 L</b>		4.035"	.039"	M110339	MLS Spartan embossed stainless steel construction.	1
		4.060"	.028"	M110628		1
			.039"	M110639		1
			.051"	M110651		1
			.039"	M110639GS	MLS Spartan with <b>Gas-Stopper</b> embossed stainless steel construction.	1
		.051"	M110651GS	1		
		4.100"	.039"	M111039	MLS Spartan embossed stainless steel construction.	1
		4.174"	.030"	M111730		1
			.039"	M111740		1
			.051"	M111751GS	MLS Spartan with <b>Gas-Stopper</b> embossed stainless steel construction.	1
		.075"	M111775	1		
		4.210"	.039"	M112139	MLS Spartan embossed stainless steel construction.	1
			.051"	M112151		1
			.067"	M112167		1
M112167	1					
<b>1970-81</b> <b>V8 · GEN 1</b> <b>400 ci · 6.6 L</b>  * Can be used on Factory 400 Small Block; head gasket incorporates center steam holes for street use.		4.134"	.039"	M111339 *	MLS Spartan embossed stainless steel construction.	1
			.051"	M111351 *		1
		4.174"	.028"	M111728 *		1
			.039"	M111739 *		1
<b>1992-97</b> <b>V8</b> <b>GEN 2</b> <b>LT1 / LT4</b> <b>350 ci</b> <b>5.7 L</b>		4.056"	.039"	M110439LT	1	
		4.111"	.039"	M111139LT	1	

**Marine Use:** stainless steel construction, all MLS Spartan head gaskets are suitable for use in marine applications.

**Chevrolet 302-400 Small Block**  
**Vulcan Cut-Ring · Performance Head Gaskets**

Application	Image	Bore Opening	Compr. Thick.	Part Number	Description	Qty.
<b>1964-91</b> <b>V8</b> <b>GEN 1</b> <b>302, 327,</b> <b>350, 400 ci</b> <b>5.0-6.6 L</b>		4.125"	.039"	CR111239	Stainless steel Cut-Ring combustion seals.  Composite gasket body construction.	1
			.051"	CR111251		1
			.059"	CR111259		1
		4.200"	.039"	CR112039		1
			.051"	CR112051		1
			.059"	CR112059		1

**Chevrolet Small Block • GEN I SBC • 283-400 ci • 4.6-6.6 L**

**Pro-Copper  
Racing Head Gaskets**

For use with o-rings & sealant

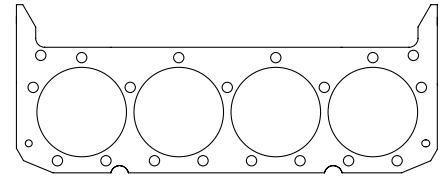
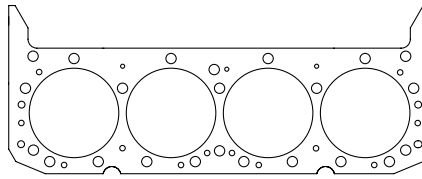

No water holes: use suffix "NW"

Bore Opening	Thickness								Qty.
	.021"	.032"	.043"	.050"	.062"	.072"	.080"	.093"	
3.850" round	P118521	P118532	P118543	P118550	P118562	P118572	P118580	P118593	1
4.010" round	P110021	P110032	P110043	P110050	P110062	P110072	P110080	P110093	1
4.060" round	P110621	P110632	P110643	P110650	P110662	P110672	P110680	P110693	1
4.160" round	P111521	P111532	P111543	P111550	P111562	P111572	P111580	P111593	1
4.200" round	P112021	P112032	P112043	P112050	P112062	P112072	P112080	P112093	1

**Titan  
Copper Racing Head Gaskets**

Sealed coolant passages, for use with o-rings & sealant

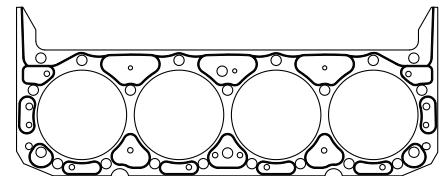

Bore Opening	Thickness								Qty.
	.021"	.032"	.043"	.050"	.062"	.072"	.080"	.093"	
3.850" round	–	T118532	T118543	T118550	T118562	T118572	T118580	T118593	1
4.010" round	–	T110032	T110043	T110050	T110062	T110072	T110080	T110093	1
4.060" round	–	T110632	T110643	T110650	T110662	T110672	T110680	T110693	1
4.160" round	–	T111532	T111543	T111550	T111562	T111572	T111580	T111593	1
4.200" round	–	T112032	T112043	T112050	T112062	T112072	T112080	T112093	1

**ICS  
Copper Racing Head Gaskets**

Sealed coolant passages, integral combustion o-ring

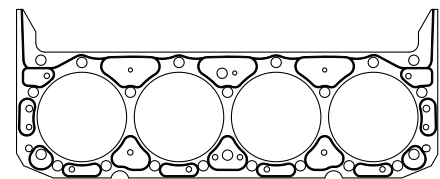

Bore Opening	Thickness								Qty.
	.021"	.032"	.043"	.050"	.062"	.072"	.080"	.093"	
3.850" round	–	–	No Fit: combustion chambers extend beyond 3.850" diameter						
4.010" round	–	–	S110043	S110050	S110062	S110072	S110080	S110093	1
4.060" round	–	–	S110643	S110650	S110662	S110672	S110680	S110693	1
4.160" round	–	–	S111543	S111550	S111562	S111572	S111580	S111593	1
4.200" round	–	–	S112043	S112050	S112062	S112072	S112080	S112093	1

**Chevrolet Small Block · GEN 2 SBC · 350 ci · 5.7 L**

**Pro-Copper  
Racing Head Gaskets**

For use with o-rings & sealant

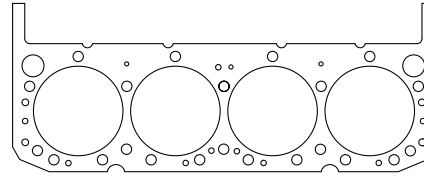

Bore Opening	Thickness								Qty.
	.021"	.032"	.043"	.050"	.062"	.072"	.080"	.093"	
4.010" round	P110021LT	P110032LT	P110043LT	P110050LT	P110062LT	P110072LT	P110080LT	P110093LT	1
4.060" round	P110621LT	P110632LT	P110643LT	P110650LT	P110662LT	P110672LT	P110680LT	P110693LT	1
4.160" round	P111521LT	P111532LT	P111543LT	P111550LT	P111562LT	P111572LT	P111580LT	P111593LT	1
4.200" round	P112021LT	P112032LT	P112043LT	P112050LT	P112062LT	P112072LT	P112080LT	P112093LT	1

**Titan  
Copper Racing Head Gaskets**

Sealed coolant passages, for use with o-rings & sealant

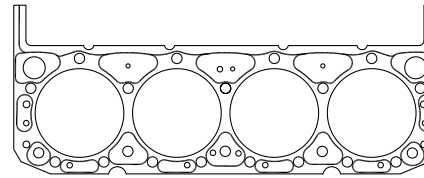

Bore Opening	Thickness								Qty.
	.021"	.032"	.043"	.050"	.062"	.072"	.080"	.093"	
4.010" round	–	T110032LT	T110043LT	T110050LT	T110062LT	T110072LT	T110080LT	T110093LT	1
4.060" round	–	T110632LT	T110643LT	T110650LT	T110662LT	T110672LT	T110680LT	T110693LT	1
4.160" round	–	T111532LT	T111543LT	T111550LT	T111562LT	T111572LT	T111580LT	T111593LT	1
4.200" round	–	T112032LT	T112043LT	T112050LT	T112062LT	T112072LT	T112080LT	T112093LT	1

**ICS  
Copper Racing Head Gaskets**

Sealed coolant passages, integral combustion o-ring

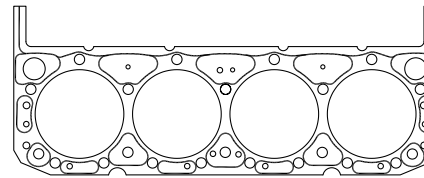

Bore Opening	Thickness								Qty.
	.021"	.032"	.043"	.050"	.062"	.072"	.080"	.093"	
4.010" round	–	–	S110043LT	S110050LT	S110062LT	S110072LT	S110080LT	S110093LT	1
4.060" round	–	–	S110643LT	S110650LT	S110662LT	S110672LT	S110680LT	S110693LT	1
4.160" round	–	–	S111543LT	S111550LT	S111562LT	S111572LT	S111580LT	S111593LT	1
4.200" round	–	–	S112043LT	S112050LT	S112062LT	S112072LT	S112080LT	S112093LT	1

**Chevrolet Gen III-IV LS Small Block · Short Block Gaskets & Seals**

Application	Oil Pan Gasket	Timing Cover Gasket	Water Pump Gasket Set	Lifter Valley Cover Gasket	Rear Main Cover Gasket	Thermostat O-Ring	Timing Cover Oil Seal	Rear Main Oil Seal	Qty.
<b>1997-Up GEN 3/4 V8 293-427 ci 4.8-7.0 L</b>									
	219090	21900	21901 <i>Alum. Core 2 pc.</i>	21904 LS1/6 1997-08	21907	21908	21902	21905	1
	1997-Up LS Series (except Corvette w/ Batwing Oil Pan)		21901-10	21909 LS2/3/7/LSX 2008-Up					Dyno-Pak 10 sets
<b>Bottom End Gasket Set:</b> 219327 · Includes all gaskets in table above.									



**Gen III-IV LS Small Block · *SBBK* – Short Block Base Kit**

Provides remaining gaskets & seals common to the engine type, regardless of customization.

**NEW!**  
— SEE P.8 —

Application	SBBK Gasket/Oil Seal Kit	Contents of Kit
<b>1997-Up V8 GEN 3/4 293-427 ci 4.8-7.0 L</b>	42003	<p><b>Includes:</b></p> <ul style="list-style-type: none"> <li>Timing Cover Gasket ·</li> <li>Water Pump Gaskets ·</li> <li>Rear Main Cover Gasket ·</li> <li>Timing Cover Seal ·</li> <li>1-pc PTFE-Lip Rear Main Seal</li> </ul>

**Chevrolet Gen III-IV LS Small Block · Valve Cover Gaskets**

Application	Molded Silicone Rubber	Hi-Density Cork 5/16" Thick	Tuff-Bak Laminated Cork		Steel Core PTFE-Coated .093" Thick (3/32")	Qty.
			1/8" Thick	1/4" Thick		
	Street / Strip		Racing / Hi-Vac		Severe Duty™	
1997-98 GEN 3 with Perimeter Bolt Valve Covers	 <p>For Use with Factory-Design Valve Covers</p>					1 Set · 2 pc
	219076	-	-	-	-	
1999-Up GEN 3-4 with Center Bolt Valve Covers	 <p>For Use with Factory-Design Valve Covers</p>					1 Set · 2 pc
	219077	-	-	-	-	

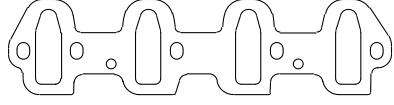
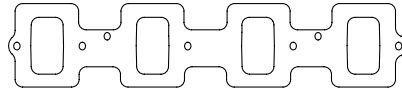
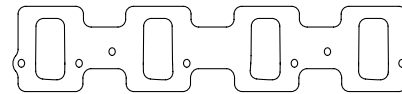

**Chevrolet Gen III-IV LS Small Block · Intake Gaskets**

Application — Port Size	Thickness	Accu-Seal E Standard Material		Accu-Seal Pro · Premium Materials	
		Packaged 1 Set	Dyno-Pak · 10 Sets	Packaged 1 Set	Dyno-Pak · 10 Sets
1997-09 V8 · GEN 3 LS1 / LS2 / LS6 4 Barre 346-364 ci 5.7-6.0 L — 1.15" X 3.37" Cathedral	 <p>Fits 4 Barrel Aftermarket Manifolds with Cathedral Ports — † Silicone Bead Sealed Ports</p>				
	.032"	119133	19133-10	-	
	.062"	119134	19134-10	219134 †	219134-10 †
	.120"	119135	19135-10	-	
2006-14 V8 · GEN 4 LS7 / CSR / World LS7X 427 ci 7.0 L — 1.38" X 2.40" Rectangle	 <p>Fits 4 Barrel Aftermarket Manifolds with Rectangular Ports</p>				
	.032"	119101	19101-10	-	
	.062"	119102	19102-10	219102	219102-10
	.120"	119106	19106-10	-	
2008-14 V8 · GEN 4 LS3/L92 376 ci 6.2 L — 1.20" X 2.51" Rectangle					
	.032"	119104	19104-10	-	
	.062"	119103	19103-10	219103	219103-10
	.120"	119105	19105-10	-	

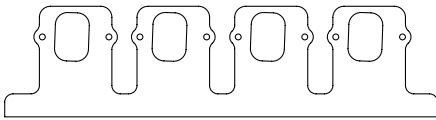
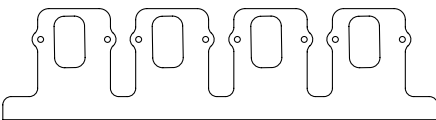
**Chevrolet Gen III-IV LS Racing Derivatives - Intake Gaskets**

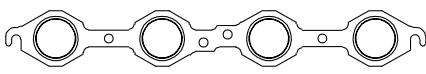
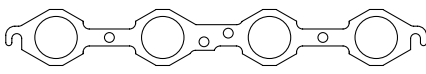

Application — Port Size	Thickness	Accu-Seal E Standard Material		Accu-Seal Pro • Premium Materials	
		Packaged 1 Set	Dyno-Pak • 10 Sets	Packaged 1 Set	Dyno-Pak • 10 Sets
<b>LSX 454 DR</b> 454 ci • 7.4 L — 1.52" X 2.19" Rectangle		Fits Chevrolet Performance D.R. (Drag Race) Manifold & Heads			
		.062"	119107	19107-10	219107
<b>LSX 454 CT</b> 454 ci • 7.4 L — 1.36" X 2.40" Rectangle		Fits Chevrolet Performance C.T. (Circle Track) Manifold & Heads			
		.062"	119108	19108-10	219108

**Chevrolet Gen III-IV LS Small Block - Exhaust Gaskets**

Application — Port Size	Accu-Seal E		Accu-Seal Pro		Graph-Form	Pro-Copper		
	Standard Material .062"		Premium Material .062"		Hi-Density Graphite .150"	Embossed .043"	Flat-Annealed .062"	
	Packaged 1 Set	Dyno-Pak 10 Sets	Packaged 1 Set	Dyno-Pak 10 Sets	Packaged 1 Set	Packaged 1 Set	Packaged 1 Set	
<b>1997-14</b> V8 • GEN 3/4 LS1 / LS2 / LS6 346-376 ci 5.7-6.2 L — Stock Port 1.62" Round								Standard LS bolt pattern fits up to 1-3/4" headers
	119080	19080-10	219180	19180-10	419180	4019	—	
<b>1997-14</b> V8 • GEN 3/4 LS1 / LS6 / LS7 / LQ9 346-427 ci 5.7-7.0 L — Large Port 1.75" Round								Standard LS bolt pattern fits up to 1-7/8" headers
	119081	19081-10	219181	19181-10	419181	4119	—	
<b>2002-14</b> V8 • GEN 3/4 LS7 / LQ9 World LS7X 364-427 ci 6.0-7.0 L — Race Port 2.13" Round								Standard LS bolt pattern fits up to 2-1/4" race headers
	—	—	—	—	—	4219	—	



**Chevrolet Gen III-IV LS Racing Derivatives - Exhaust Gaskets**

Application — Port Size	Accu-Seal E		Accu-Seal Pro		Graph-Form	Pro-Copper			
	Standard Material .062"		Premium Material .062"		Hi-Density Graphite .150"	Embossed .043"	Flat-Annealed .062"		
	Packaged 1 Set	Dyno-Pak 10 Sets	Packaged 1 Set	Dyno-Pak 10 Sets	Packaged 1 Set	Packaged 1 Set	Packaged 1 Set		
Arias LS Hemi Head GEN 3/4 — 1.87" Round					Unique bolt pattern fits only Arias LS Hemi, seals 2" header opening				
								-	-
LSX 454 D GEN 3/4 454 ci · 7.4 L — 1.90" Round									
					-	-	-	4419	-

**Chevrolet Gen III-IV LS Small Block**  
**MLS Spartan · Performance Head Gaskets**

Application	Image	Bore Opening	Compr. Thick.	Part Number	Description	Qty.
1997-04 V8 GEN 3 LS 10-bolt 293-346 ci 4.8-5.7 L		3.945"	.039"	M209439	MLS embossed stainless steel construction.	1
			.051"	M209451		1
2005-14 V8 GEN 4 LS 10-bolt 364-376 ci 6.0-6.2 L		4.100"	.039"	M201039		1
			.051"	M201051		1
		4.130"	.039"	M201339		1
			.051"	M201351		1
		4.162"	.051"	M201651		1
		2006-Up LS7 427 ci · 7.0 L	 Perimeter sealing suitable for use with Darton M.I.D. sleeves.	4.162"		.051"
GEN 4 LSX 18-bolt 376 ci 6.1 L		4.123"	.051"	M191251L Left*		1
				M191251R Right*		1
GEN 4 LSX 18-bolt 454 ci 7.4 L	* Note: LSX 18-bolt head gaskets cannot be reversed, upper bolt locations of left/right gaskets are slightly different.	4.200"	.051"	M192051L Left*	1	
				M192051R Right*	1	

All Gen 3-4 MLS Spartan Head Gaskets will accommodate **1/2" head studs.**

**Marine Use:** stainless steel construction, all MLS Spartan head gaskets are suitable for use in marine applications.

**Chevrolet Gen III-IV LS Small Block ·  
Vulcan Cut-Ring · Performance Head Gaskets**

Application	Image	Bore Opening	Compr. Thick.	Part Number	Description	Qty.	
<b>1997-14 V8 GEN 3/4 LS 10-Bolt 293-376 ci 4.8-6.2 L</b>		4.056"	.059"	CR200559	Stainless steel Cut-Ring combustion seals (not pictured).	1	
		4.150"		CR201559	Composite gasket body construction.	1	
<b>GEN 4 LSX 18-bolt 364-454 ci 6.0-7.4 L</b>	<p>* Note: LSX 18-bolt head gaskets cannot be reversed, upper bolt locations of left/right gaskets are slightly different.</p>	3.997"	.059"	CR199959L <i>Left</i>	Stainless steel Cut-Ring combustion seals (not pictured).  Composite gasket body construction.	1	
				CR199959R <i>Right</i>		1	
		4.050"		CR190559L <i>Left</i>		1	
				CR190559R <i>Right</i>		1	
		4.150"		CR191559L <i>Left</i>		1	
				CR191559R <i>Right</i>		1	
		4.174"		CR191759L <i>Left</i>		1	
				CR191759R <i>Right</i>		1	
		4.200"		.039"		CR192039L <i>Left</i>	1
						CR192039R <i>Right</i>	1
				.051"		CR192051L <i>Left</i>	1
						CR192051R <i>Right</i>	1
				.059"		CR192059L <i>Left</i>	1
						CR192059R <i>Right</i>	1
All Gen 3-4 Vulcan Cut-Ring Head Gaskets will accommodate 1/2" head studs.							

**Chevrolet Performance LSX · V8 · 18-bolt · 364-454 ci · 6.0-7.4 L**

**Pro-Copper  
Racing Head Gaskets**

For use with o-rings & sealant

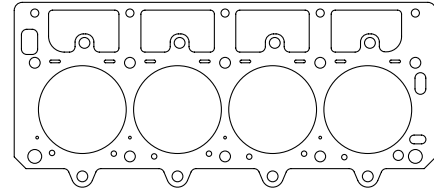

Bore Opening	Thickness								Qty.
	.021"	.032"	.043"	.050"	.062"	.072"	.080"	.093"	
3.950" round	P199521L P199521R	P199532L P199532R	P199543L P199543R	P199550L P199550R	P199562L P199562R	P199572L P199572R	P199580L P199580R	P199593L P199593R	1
4.010" round	P190021L P190021R	P190032L P190032R	P190043L P190043R	P190050L P190050R	P190062L P190062R	P190072L P190072R	P190080L P190080R	P190093L P190093R	1
4.060" round	P190621L P190621R	P190632L P190632R	P190643L P190643R	P190650L P190650R	P190662L P190662R	P190672L P190672R	P190680L P190680R	P190693L P190693R	1
4.135" round	P191321L P191321R	P191332L P191332R	P191343L P191343R	P191350L P191350R	P191362L P191362R	P191372L P191372R	P191380L P191380R	P191393L P191393R	1
4.160" round	P191621L P191621R	P191632L P191632R	P191643L P191643R	P191650L P191650R	P191662L P191662R	P191672L P191672R	P191680L P191680R	P191693L P191693R	1
4.200" round	P192021L P192021R	P192032L P192032R	P192043L P192043R	P192050L P192050R	P192062L P192062R	P192072L P192072R	P192080L P192080R	P192093L P192093R	1

**Titan  
Copper Racing Head Gaskets**

Sealed coolant passages, for use with o-rings

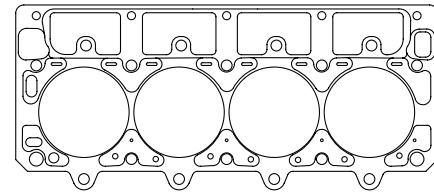

Bore Opening	Thickness								Qty.
	.021"	.032"	.043"	.050"	.062"	.072"	.080"	.093"	
3.950" round	-	T199532L T199532R	T199543L T199543R	T199550L T199550R	T199562L T199562R	T199572L T199572R	T199580L T199580R	T199593L T199593R	1
4.010" round	-	T190032L T190032R	T190043L T190043R	T190050L T190050R	T190062L T190062R	T190072L T190072R	T190080L T190080R	T190093L T190093R	1
4.060" round	-	T190632L T190632R	T190643L T190643R	T190650L T190650R	T190662L T190662R	T190672L T190672R	T190680L T190680R	T190693L T190693R	1
4.135" round	-	T191332L T191332R	T191343L T191343R	T191350L T191350R	T191362L T191362R	T191372L T191372R	T191380L T191380R	T191393L T191393R	1
4.160" round	-	T191632L T191632R	T191643L T191631R	T191650L T191650R	T191662L T191662R	T191672L T191672R	T191680L T191680R	T191693L T191693R	1
4.200" round	-	T192032L T192032R	T192043L T192043R	T192050L T192050R	T192062L T192062R	T192072L T192072R	T192080L T192080R	T192093L T192093R	1

All Gen 3-4 Pro Copper, Titan, & ICS Head Gaskets will accommodate **1/2" head studs**.  
**Note:** LSX 18-bolt head gaskets cannot be reversed, upper bolt locations of left/right gaskets are slightly different.

*ICS on next page »*

**Chevrolet Performance LSX · V8 · 18-bolt · 364-454 ci · 6.0-7.4 L**

**ICS**  
**Copper Racing Head Gaskets**

Sealed coolant passages, integral combustion o-ring

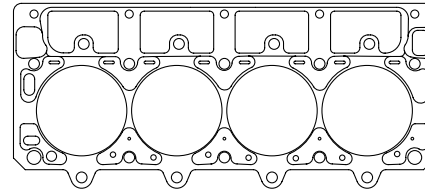

Bore Opening	Thickness								Qty.
	.021"	.032"	.043"	.050"	.062"	.072"	.080"	.093"	
3.950" round	—	—	S199543L S199543R	S199550L S199550R	S199562L S199562R	S199572L S199572R	S199580L S199580R	S199593L S199593R	1
4.010" round	—	—	S190043L S190043R	S190050L S190050R	S190062L S190062R	S190072L S190072R	S190080L S190080R	S190093L S190093R	1
4.060" round	—	—	S190643L S190643R	S190650L S190650R	S190662L S190662R	S190672L S190672R	S190680L S190680R	S190693L S190693R	1
4.135" round	—	—	S191343L S191343R	S191350L S191350R	S191362L S191362R	S191372L S191372R	S191380L S191380R	S191393L S191393R	1
4.160" round	—	—	S191643L S191643R	S191650L S191650R	S191662L S191662R	S191672L S191672R	S191680L S191680R	S191693L S191693R	1
4.200" round	—	—	S192043L S192043R	S192050L S192050R	S192062L S192062R	S192072L S192072R	S192080L S192080R	S192093L S192093R	1

**Note:** LSX 18-bolt head gaskets cannot be reversed, upper bolt locations of left/right gaskets are slightly different.  
All Gen 3-4 Pro Copper, Titan, & ICS Head Gaskets will accommodate **1/2" head studs.**

« **Pro-Copper & Titan on previous page**

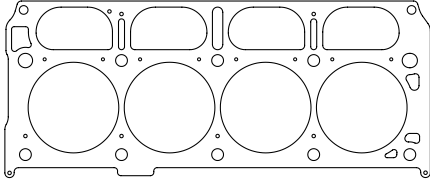

**Chevrolet Gen V · LT 1 & LT 4 · Small Block**  
**MLS Spartan · Performance Head Gaskets**

Application	Image	Bore Opening	Compr. Thick.	Part Number	Description	Qty.
2014-Up V8 GEN V 10-bolt 376 ci 6.2 L		4.100"	.051"	M271051GS	MLS Spartan with <b>Gas-Stopper</b> embossed stainless steel construction.	1
		4.150"		M271551GS		1
		4.200"		M272051GS		1
<b>Marine Use:</b> stainless steel construction, all MLS Spartan head gaskets are suitable for use in marine applications.						

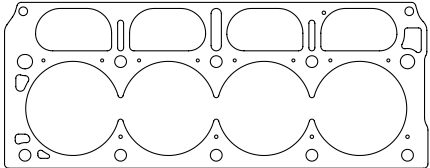
**Chevrolet Gen V · LT 1 & LT 4 · Small Block**  
**Vulcan Cut-Ring · Performance Head Gaskets**

Application	Image	Bore Opening	Compr. Thick.	Part Number	Description	Qty.
2014-Up V8 GEN V 10-bolt 376 ci 6.2 L		4.100"	.056"	CR271055	Stainless steel Cut-Ring combustion seals (not pictured).  Composite gasket body construction.	1
		4.150"		CR271555		1
		4.200"		CR272055		1

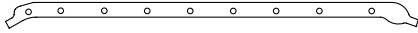
## Chevrolet 396-454 Big Block · Short Block Gaskets & Seals

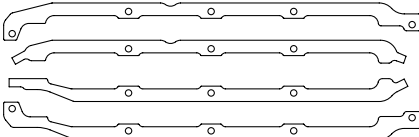
Application	Oil Pan Gasket Set	Timing Cover Gasket Set	Front Cover Gasket Set TC · WP · FP	Water Pump Gasket Set	Fuel Pump Gasket	Water Outlet Gasket	Timing Cover Oil Seal	Rear Main Oil Seal	Qty.
<b>1965-90 V8 MK IV</b> 396-454 ci 6.5-7.4 L	 113090 * <p style="text-align: right;"><b>Accu-Seal E</b> standard gasket materials, nitrile or silicone seals.</p> <p style="text-align: right;">* OEM-style 4-pc set w/ rubberized fiber rails (end seals not pictured).</p>								
	113090 *	11303	11300	11301	11106 <i>supersedes 11306</i>	11108 <i>supersedes 11308</i>	11302	11305 2 Pc.	1 Set
	13090-10 *	—	1300-10	1301-10	1106-10 <i>supersedes 1306-10</i>	1108-10 <i>supersedes 1308-10</i>	1302-10	1305-10	Dyno-Pak 10 Sets
	 213090 † <p style="text-align: right;"><b>Accu-Seal Pro</b> premium gasket materials, FKM seals, molded water outlet.</p> <p style="text-align: right;">† 1-pc molded silicone with extra rod-stroke clearance. Steel backbone &amp; crush limiters.</p>								
	213090 †	—	—	21301 <i>Steel-Core 2 Pc.</i>	—	21308	21302	21305 2 Pc.	1 Set
213090-10 †	—	—	21301-10	—	21308-10	21302-10	21305-10	Dyno-Pak 10 Sets	
<b>396-454 MK IV</b>  <b>with Moroso Wet Sump Stroker</b>	 113094 * 213194 † <p style="text-align: right;"><b>Accu-Seal E</b> standard gasket materials</p> <p style="text-align: right;">* Rubberized fiber rails</p> <p style="text-align: right;">Fits Moroso stroker wet sump oil pan. 6-pc set for use with girdle (end seals not pictured).</p>								
	113094 *	11303	11300	11301	11106 <i>supersedes 11306</i>	11108 <i>supersedes 11308</i>	11302	11305 2 Pc.	1 Set
	13094-10 *	—	1300-10	1301-10	1106-10 <i>supersedes 1306-10</i>	1108-10 <i>supersedes 1308-10</i>	1302-10	1305-10	Dyno-Pak 10 Sets
	<p style="text-align: right;"><b>Accu-Seal Pro</b> premium gasket materials · † Severe Duty™, .093" thick PTFE-coated, steel-core material.</p>								
	213194 †	—	—	21301 <i>Steel-Core 2 Pc.</i>	—	21308	21302	21305 2 Pc.	1 Set
213194-10 †	—	—	21301-10	—	21308-10	21302-10	21305-10	Dyno-Pak 10 Sets	

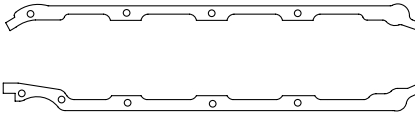

**Chevrolet 396-454 Big Block · Short Block Gaskets & Seals**

Application	Oil Pan Gasket Set	Timing Cover Gasket Set	Front Cover Gasket Set TC · WP · FP	Water Pump Gasket Set	Fuel Pump Gasket	Water Outlet Gasket	Timing Cover Oil Seal	Rear Main Oil Seal	Qty.
<b>396-454 MK IV</b>  <b>with Extra Rod-Stroke Clearance</b>	 <p><b>Accu-Seal E</b> standard gasket materials</p> <p>* Rubberized fiber rails Extra rod-stroke clearance, pan bolts at main caps. 4-pc set (end seals not pictured).</p>								
	113095 *	11303	11300	11301	11106 <i>supersedes 11306</i>	11108 <i>supersedes 11308</i>	11302	11305 2 Pc.	1 Set
	13095-10 *	—	1300-10	1301-10	1106-10 <i>supersedes 1306-10</i>	1108-10 <i>supersedes 1308-10</i>	1302-10	1305-10	Dyno-Pak 10 Sets
	<p><b>Accu-Seal Pro</b> premium gasket materials · † Severe Duty™, .093" thick PTFE-coated, steel-core material.</p>								
	213195 †	—	—	21301 <i>Steel-Core 2 Pc.</i>	—	21308	21302	21305 2 Pc.	1 Set
213195-10 †	—	—	21301-10	—	21308-10	21302-10	21305-10	Dyno-Pak 10 Sets	

**Chevrolet 454-572 GEN V-VI Big Block · Short Block Gaskets & Seals**

Application	Oil Pan Gasket Set	Timing Cover Gasket Set	Front Cover Gasket Set TC · WP · FP	Water Pump Gasket Set	Fuel Pump Gasket	Water Outlet Gasket	Timing Cover Oil Seal	Rear Main Oil Seal	Qty.
<b>1991-Up V8 GEN V-VI 454-572 ci 7.4-9.4 L</b>	<p><b>Accu-Seal E</b> standard gasket materials, nitrile or silicone seals.</p>								
	—	11403	11309	11301	11106 <i>supersedes 11306</i>	11108 <i>supersedes 11308</i>	11302	—	1 Set
	—	—	1309-10	1301-10	1106-10 <i>supersedes 1306-10</i>	1108-10 <i>supersedes 1308-10</i>	1302-10	—	Dyno-Pak 10 Sets
	 <p><b>Accu-Seal Pro</b> premium gasket materials, FKM seals, molded water outlet.</p> <p>† 1-pc molded silicone. Steel backbone &amp; crush limiters.</p>								
	213091 †	—	—	21301 <i>Steel-Core 2 Pc.</i>	—	21308	21302	21355 1 Pc.	1 Set
213091-10 †	—	—	21301-10	—	21308-10	21302-10	21305-10	Dyno-Pak 10 Sets	

**BBC Racing Derivatives · Short Block Gaskets & Seals**

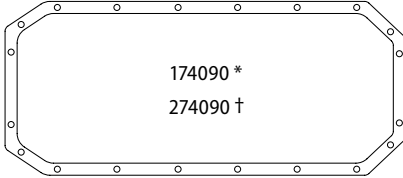
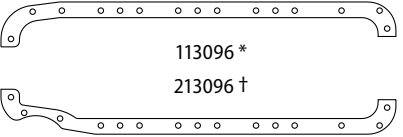
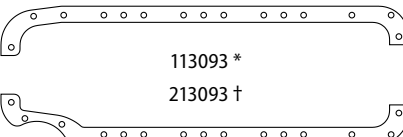
Application	Oil Pan Gasket Set	Timing Cover Gasket Set	Front Cover Gasket Set TC · WP · FP	Water Pump Gasket Set	Fuel Pump Gasket	Water Outlet Gasket	Timing Cover Oil Seal	Rear Main Oil Seal	Qty.
<b>AJPE 481X</b>	 <p>174090 * 274090 †</p> <p><b>Accu-Seal E</b> standard gasket materials — * Rubberized fiber rails</p>								
	174090 *	-	-	-	-	-	11302	11305 2 Pc.	1 Set
	74090-10 *	-	-	-	-	-	1302-10	1305-10	Dyno-Pak 10 Sets
	<b>Accu-Seal Pro</b> premium gasket materials · † Severe Duty™, .093" thick PTFE-coated, steel-core material.								
	274090 †	-	-	-	-	-	21302	21305 2 Pc.	1 Set
	274090-10 †	-	-	-	-	-	21302-10	21305-10	Dyno-Pak 10 Sets
<b>Donovan 500</b>	 <p>113096 * 213096 †</p> <p><b>Accu-Seal E</b> standard gasket materials * Rubberized fiber rails</p>								
	113096 *	11310	-	11301	-	-	11302	11305 2 Pc.	1 Set
	13096-10 *	1310-10	-	1301-10	-	-	1302-10	1305-10	Dyno-Pak 10 Sets
	<b>Accu-Seal Pro</b> premium gasket materials · † Severe Duty™, .093" thick PTFE-coated, steel-core material.								
	213096 †	-	-	-	-	-	21302	21305 2 Pc.	1 Set
	213096-10 †	-	-	-	-	-	21302-10	21305-10	Dyno-Pak 10 Sets
<b>Donovan 700</b>	 <p>113093 * 213093 †</p> <p><b>Accu-Seal E</b> standard gasket materials * Rubberized fiber rails</p>								
	113093 *	11310	-	11301	-	-	11302	11305 2 Pc.	1 Set
	13093-10 *	1310-10	-	1301-10	-	-	1302-10	1305-10	Dyno-Pak 10 Sets
	<b>Accu-Seal Pro</b> premium gasket materials · † Severe Duty™, .093" thick PTFE-coated, steel-core material.								
	213093 †	-	-	-	-	-	21302	21305 2 Pc.	1 Set
	213093-10 †	-	-	-	-	-	21302-10	21305-10	Dyno-Pak 10 Sets

**BBC Racing Derivatives · Short Block Gaskets & Seals**

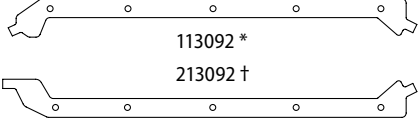
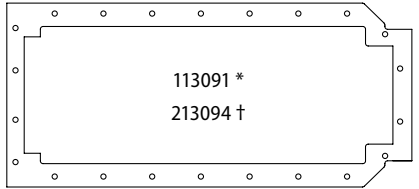
Application	Oil Pan Gasket Set	Timing Cover Gasket Set	Front Cover Gasket Set TC · WP · FP	Water Pump Gasket Set	Fuel Pump Gasket	Water Outlet Gasket	Timing Cover Oil Seal	Rear Main Oil Seal	Qty.
<b>GM DRCE</b> · <b>World Products Merlin</b>	 <p><b>Accu-Seal E</b> standard gasket materials — * Rubberized fiber rails 4-pc set (end seals not pictured).</p>								
	113092 *	11303	11300	11301	—	11108 <i>supersedes</i> 11308	11302	11305 2 Pc.	1 Set
	13092-10 *	—	1300-10	1301-10	—	1108-10 <i>supersedes</i> 1308-10	1302-10	1305-10	Dyno-Pak 10 Sets
	<p><b>Accu-Seal Pro</b> premium gasket materials · † Severe Duty™, .093" thick PTFE-coated, steel-core material.</p>								
	213192 †	—	—	21301 <i>Steel-Core</i> 2 Pc.	—	21308	21302	21305 2 Pc.	1 Set
13192-10 †	—	—	21301-10	—	21308-10	21302-10	21305-10	Dyno-Pak 10 Sets	
<b>New Century</b> · <b>KB Olds</b> · <b>CN 1040Y</b> with <b>New Century</b> pan rails	 <p><b>Accu-Seal E</b> standard gasket materials * Rubberized fiber rails</p>								
	113091 *	—	—	—	—	—	11302	11305 2 Pc.	1 Set
	13091-10 *	—	—	—	—	—	1302-10	1305-10	Dyno-Pak 10 Sets
	<p><b>Accu-Seal Pro</b> premium gasket materials · † Severe Duty™, .093" thick PTFE-coated, steel-core material.</p>								
	213094 †	—	—	—	—	—	21302	21305 2 Pc.	1 Set
213094-10 †	—	—	—	—	—	21302-10	21305-10	Dyno-Pak 10 Sets	

**NEW!**  
— SEE P.8 —

**BBC · Mark IV · GEN V-VI · SBBK – Short Block Base Kit**

Provides remaining gaskets and seals common to the engine type, regardless of customization.

Application	SBBK Gasket/Oil Seal Kit	Contents of Kit	
1965-90 V8 MK IV 396-454 ci 6.5-7.4 L	31303		31303 · 41303
1965-90 V8 MK IV 396-454 ci 6.5-7.4 L	41303		<b>Includes:</b> Timing Cover · Water Pump · Fuel Pump · Water Outlet Gasket · Timing Cover Seal · 2-pc Silicone Rear Main Seal
1991-Up V8 GEN V-VI 454-572 ci 7.4-9.4 L	41355		<b>Includes:</b> Timing Cover · Water Pump · Fuel Pump · Water Outlet Gasket · Timing Cover Seal · 1-pc FKM Rear Main Seal

**Chevrolet 396-454 Big Block · Valve Cover Gaskets**

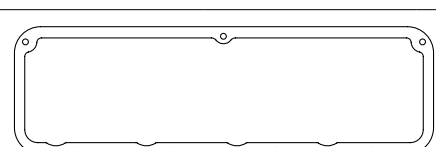
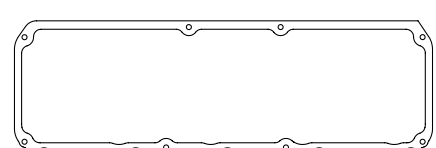
Application	Molded Silicone Rubber	Hi-Density Cork 5/16" Thick	Tuff-Bak Laminated Cork		Steel Core PTFE-Coated .093" Thick (3/32")	Qty.
			1/8" Thick	1/4" Thick		
Street / Strip		Racing / Hi-Vac		Severe Duty™		
1965-Up V8 MK IV · GEN V 396-572 ci 6.5-9.4 L			7 bolts, 3-over-4 pattern			
	213077 *	113076	213075	213076	213078	1 Set
	213077-10	13076-10	213075-10	213076-10	213078-10	Dyno-Pak 10 Sets
<b>Racing Derivatives</b>						
AJPE 481-X Stage I-III · GM DRCE 1			7 bolts, 3-over-4 bolt pattern			
	-	-	274074	274076	274175	1 Set
	-	-	274074-10	274076-10	274175-10	Dyno-Pak 10 Sets
AJPE 481-X Stage IV			8 bolts, 4-over-4 bolt pattern			
	-	-	274078	274079	274176	1 Set
	-	-	274078-10	274079-10	274176-10	Dyno-Pak 10 Sets

**BBC Racing Derivatives · Valve Cover Gaskets**

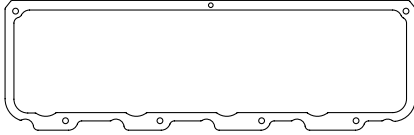
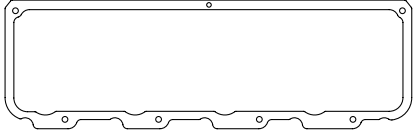
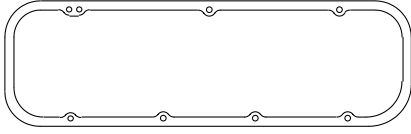
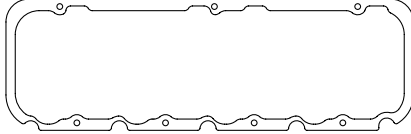
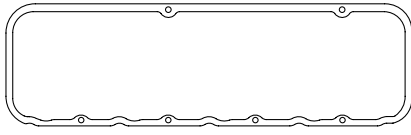
Application	Molded Silicone Rubber	Hi-Density Cork 5/16" Thick	Tuff-Bak Laminated Cork		Steel Core PTFE-Coated .093" Thick (3/32")	Qty.
			1/8" Thick	1/4" Thick		
			Street / Strip			
AJPE 4.9" NHRA Pro Stock	 <p>7 bolts, 3-over-4 bolt pattern</p>					1 Set
						215175
	-	-	215175-10	215176-10	215178-10	Dyno-Pak 10 Sets
AJPE 5.0" IHRA Pro Stock	 <p>7 bolts, 3-over-4 bolt pattern</p>					1 Set
						255175
	-	-	255175-10	255176-10	255178-10	Dyno-Pak 10 Sets
Brodix SR20	 <p>8 bolts, 2+1+1 over 4 pattern</p>					1 Set
						218275
	-	-	218275-10	218278-10	218278-10	Dyno-Pak 10 Sets
Brodix DN-9 / PB 1200 Series	 <p>7 bolts, 3-over-4 pattern</p>					1 Set
						213375
	-	-	213375-10	213376-10	213377-10	Dyno-Pak 10 Sets
Brodix PB 5000 5.0"	 <p>6 bolts, 2-over-4 pattern fits Brodix BP, PB 5000 series 5" bore spacing heads</p>					1 Set
						295175
	-	-	295175-10	295176-10	295178-10	Dyno-Pak 10 Sets

**BBC Racing Derivatives - Valve Cover Gaskets**

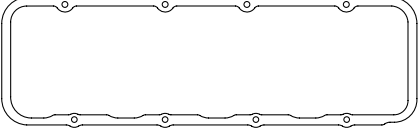
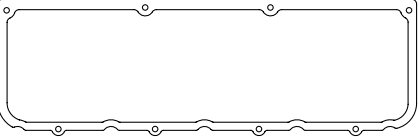
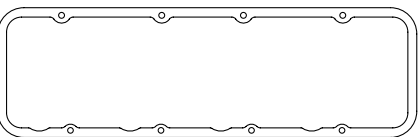
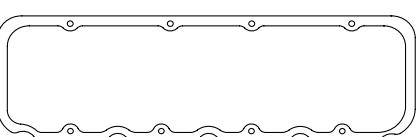
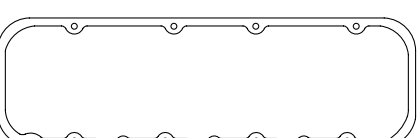
Application	Molded Silicone Rubber	Hi-Density Cork 5/16" Thick	Tuff-Bak Laminated Cork		Steel Core PTFE-Coated .093" Thick (3/32")	Qty.
			1/8" Thick	1/4" Thick		
	Street / Strip		Racing / Hi-Vac		Severe Duty™	
Brodix / Eicke 5.0"			8 bolts, 4-over-4 pattern			
	-	-	275375-10	275376-10	275378-10	Dyno-Pak 10 Sets
GM DRCE II 4.900"			8 bolts, 4-over-4 pattern			
	-	-	276071-10	276072-10	276178-10	Dyno-Pak 10 Sets
Dart Big Chief, Brodix Big Duke, Pontiac Super Duty			8 bolts, 4-over-4 pattern			
	-	-	218075-10	218076-10	218078-10	Dyno-Pak 10 Sets
Fulton / CFE 5.0"			8 bolts, 4-over-4 pattern			
	-	-	250175-10	250176-10	250178-10	Dyno-Pak 10 Sets
Reher & Morrison 'Raptor'			8 bolts, 4-over-4 pattern			
	-	-	218175-10	218176-10	218178-10	Dyno-Pak 10 Sets

**BBC Racing Derivatives · Valve Cover Gaskets**





Application	Molded Silicone Rubber	Hi-Density Cork 5/16" Thick	Tuff-Bak Laminated Cork		Steel Core PTFE-Coated .093" Thick (3/32")	Qty.	
			1/8" Thick	1/4" Thick			
	Street / Strip		Racing / Hi-Vac		Severe Duty™		
Sonny's 5.0" Billet 813 ci			8 bolts, 4-over-4 pattern				
							240175
	-	-	240175-10	240176-10	240178-10	Dyno-Pak 10 Sets	
Sonny's 5.3", 5.4"			7 bolts, 3-over-4 bolt pattern				
							243175
	-	-	243175-10	243176-10	243178-10	Dyno-Pak 10 Sets	
Universal Valve Cover Breather Gaskets			Meets NHRA breather gasket rules, 2 bolts, standard shape fits all popular breathers				
							16604
	-	-	16604-10	26604-10	Dyno-Pak 10 Sets		

**Chevrolet 396-454 Big Block · Intake Gaskets**

Application — Port Size	Thickness	Accu-Seal E Standard Material		Accu-Seal Pro · Premium Materials							
		Packaged 1 Set	Dyno-Pak · 10 Sets	Packaged 1 Set	Dyno-Pak · 10 Sets						
BBC Intake Blank			Standard BBC outline shape with bolt holes, no intake or water ports								
							.062"	113100	13100-10	213100	213100-10
1965-90 V8 · MK IV 396-454 ci 6.5-7.4 L — 1.79" x 2.03" Stock Oval Port			Fits Chevrolet oval port, Edelbrock E-street Big Block, Brodix FF-010 & similar heads — † Silicone Bead Sealed Ports								
							.062"	113101	13101-10	213101 †	213101-10 †
							.120"	113106	13106-10	—	

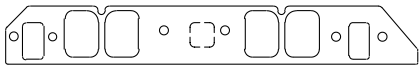

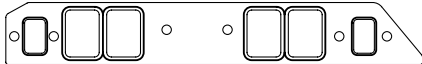
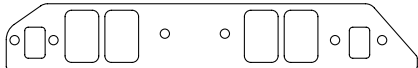
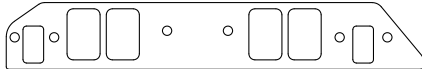
## Chevrolet 396-454 Big Block · Intake Gaskets

Application — Port Size	Thickness	Accu-Seal E Standard Material		Accu-Seal Pro · Premium Materials	
		Packaged 1 Set	Dyno-Pak · 10 Sets	Packaged 1 Set	Dyno-Pak · 10 Sets
<b>1965-90 V8 · MK IV 396-454 ci 6.5-7.4 L</b> — <b>1.78" x 2.54" HP Rectangle Port</b>	 <p style="text-align: center;">Fits Chevrolet HP rectangle, Edelbrock RPM 454, Brodix JJ294 &amp; similar heads — † Silicone Bead Sealed Ports</p>				
	.062"	113102	13102-10	213102 †	213102-10 †
	.120"	113103	13103-10	—	
<b>Racing Derivatives</b>					
<b>Copper Distributor/ Magneto Shims</b>	 <ul style="list-style-type: none"> <li>Allows optimization of distributor gear &amp; camshaft gear interface.</li> <li>Allows adjustment of distributor to oil pump drive shaft clearance.</li> <li>Improves distributor/magneto grounding.</li> </ul>				
	.010"	—		202C	202C-10
<b>BBC No Top Bolts</b> — <b>1.80" x 2.50" Large Rectangle</b>	 <p style="text-align: center;">Fits Dart 360, Edelbrock Victor, Brodix BB1–BB4 &amp; similar heads with large rectangle ports &amp; no top bolts — † Silicone Bead Sealed Ports</p>				
	.031"	113117	13117-10	—	
	.062"	113115	13115-10	213115 †	213115-10 †
	.120"	113116	13116-10	—	
<b>CFE BMF 405</b> — <b>1.80" x 2.80" Large Rectangle</b>	 <p style="text-align: center;">Fits CFE BMF 405cc. Port matched to CFE finished CNC ported head.</p>				
	.062"	113108	13108-10	213108	213108-10
<b>Dart Big M</b> — <b>1.72" x 2.72" Large Rectangle</b>	 <p style="text-align: center;">Fits Dart Big M extra-large rectangle intake ports, no top bolts.</p>				
	.062"	113104	13104-10	213104	213104-10
<b>RHS 320/360</b> — <b>1.72" x 2.45" Large Rectangle</b>	 <p style="text-align: center;">Fits RHS &amp; Pro Topline 320/360. Port matched to RHS finished port size.</p>				
	.062"	113107	13107-10	213107	213107-10
<b>Brodix BB-3 Xtra™</b> — <b>1.82" x 2.54" Rectangular</b>	 <p style="text-align: center;">Fits BB-3 Xtra Rectangular, CNC ported by Brodix.</p>				
	.062"	113105	13105-10	213105	213105-10

**BBC Racing Derivatives · Intake Gaskets**

Application — Port Size	Thickness	Accu-Seal E Standard Material		Accu-Seal Pro · Premium Materials		
		Packaged 1 Set	Dyno-Pak · 10 Sets	Packaged 1 Set	Dyno-Pak · 10 Sets	
Brodix SR 20 — 1.83" x 2.58" Rectangular			Fits Brodix SR 20 heads with 20° valve angle.			
	.062"	113141	13141-10	213141	213141-10	
Brodix / Pontiac Super Duty — 1.92" x 2.70" Rectangle			Fits Brodix / Pontiac Super Duty. Siamesed ports, casting number 5427.			
	.062"	113140	13140-10	213140	213140-10	
Pontiac Super Duty — 1.75" x 2.45" Rectangle			Fits Pontiac Super Duty. Raised siamesed ports, casting number 9875.			
	.062"	113138	13138-10	213138	213138-10	
Raised Port Intake Blank			Raised outline shape, no bolt holes, no ports.			
	.062"	118100	18100-10	218100	218100-10	
	.120"	118125	18125-10	—	—	
Dart Big Chief CNC — N/A (Trim-to-Fit)			Fits Dart Big Chief CNC heads, sufficient material to port match any CNC port.			
	.062"	118108	18108-10	218108	218108-10	
Dart Big Chief — 1.84" x 2.69" Rectangle			Fits Dart Big Chief & Brodix Big Duke cast heads with rectangle ports			
	.062"	118101	18101-10	218101	218101-10	
	.120"	118106	18106-10	—	—	
Dart Big Chief — 1.65" x 2.45" Small Oval			Fits Dart Big Chief with small oval ports			
	.062"	118102	18102-10	218102	218102-10	
Dart Big Chief — 1.95" x 2.65" Large Oval			Fits Dart Big Chief with large oval ports			
	.062"	118104	18104-10	218104	218104-10	
	.120"	118105	18105-10	—		

**BBC Racing Derivatives · Intake Gaskets**

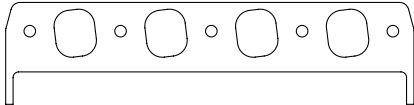
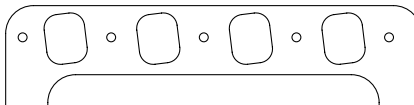
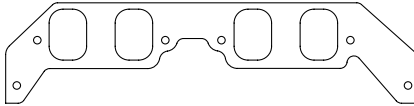
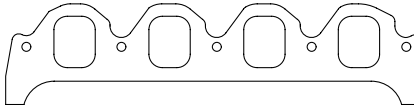
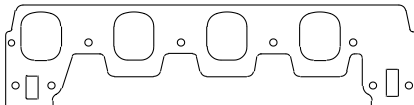
Application — Port Size	Thickness	Accu-Seal E Standard Material		Accu-Seal Pro · Premium Materials	
		Packaged 1 Set	Dyno-Pak · 10 Sets	Packaged 1 Set	Dyno-Pak · 10 Sets
<b>AJPE 481X Blower Manifold End Seals</b>	 <p>Compressible foam, fits into AJPE 481X blower manifold end rails.</p>				
	.500" Uncompressed	27401	27401-10	—	—
<b>AJPE 4.9" NHRA Pro Stock — 2.19" x 2.54" Canted Oval</b>	 <p>Fits AJPE 4.9" NHRA Pro Stock port-matched to AJPE CNC ported head</p>				
	.062"	115101	15101-10	215101	215101-10
<b>AJPE 5.0" Mountain Motor Pro Stock — 2.16" x 2.70" Canted Oval</b>	 <p>Fits AJPE 5.0" port-matched to AJPE CNC ported head</p>				
	.062"	155102	55102-10	255102	255102-10
<b>Brodix PB 5000 5.0" — 2.02" x 2.75" Oval</b>	 <p>Fits Brodix PB, BP 5000 series 5" bore center heads</p>				
	.062"	195101	95101-10	295101	295101-10
<b>Sonny's Wedge 5.3 — 2.30" x 2.88" Oval</b>	 <p>Fits Sonny's 5.3" Wedge.</p>				
	.062"	143105	143105-10	243105	243105-10
<b>Sonny's 5.3 · 5.4 — 2.18" x 2.64" Oval</b>	 <p>Fits Sonny's 5.3", 5.4". Sonny's 813 &amp; Billet 5" heads.</p>				
	.062"	140101	140101-10	240101	240101-10

**Chevrolet 396-454 Mark IV Big Block · Exhaust Gaskets**

Application — Port Size	Accu-Seal E		Accu-Seal Pro		Graph-Form	Pro-Copper	
	Standard Material .062"		Premium Material .062"		Hi-Density Graphite .150"	Embossed .043"	Flat-Annealed .062"
	Packaged 1 Set	Dyno-Pak 10 Sets	Packaged 1 Set	Dyno-Pak 10 Sets	Packaged 1 Set	Packaged 1 Set	Packaged 1 Set
1965-90 MK IV 396-454 ci 6.5-7.4 L — 1.85" Round			Fits up to 1.875" O.D. round port headers				
	113080	13080-10	213180	13180-10	413180	4013	E13186
1965-Up MK IV GEN V-VI 396-572 ci 6.5-9.4 L — 2.00" Round			Fits up to 2.125" O.D. round port headers				
	113081	13081-10	213181	13181-10	413181	4313	E13286
1965-Up MK IV GEN V-VI 396-572 ci 6.5-9.4 L — 2.25" Round			Fits up to 2.375" O.D. racing headers				
	113084	13084-10	213184	13184-10	413184	4213	E18186
1965-90 MK IV 396-454 ci 6.5-7.4 L — 1.87" x 1.80" Square			Fits stock cast iron manifold, Hedman #2455 and similar square port headers				
	113082	13082-10	213182	13182-10	413182	4113	E13187
1965-90 MK IV 396-454 ci 6.5-7.4 L — 2.02" x 2.02" Lg. Square			Fits cast aluminum marine water cooled manifolds and similar large square port headers				
	113083	13083-10	213183	13183-10	413183	-	-
GEN V-VI 396-502 ci 6.5-8.2 L — 1.52" x 1.65" "D" port			Fits Chevrolet Performance 502 ci "D" port configuration with raised port centerline				
	113085	13085-10	213185	213185-10	413185	4413	-
GEN V-VI 396-572 ci 6.5-9.4 L — 1.94" x 1.68" "D" port			Fits Chevrolet Performance 572 ci large "D" port configuration with raised port centerline				
	113086	-	-	-	413186	4513	-

**BBC Racing Derivatives · Exhaust Gaskets**

Application — Port Size	Accu-Seal E		Accu-Seal Pro		Graph-Form	Pro-Copper	
	Standard Material .062"		Premium Material .062"		Hi-Density Graphite .150"	Embossed .043"	Flat-Annealed .062"
	Packaged 1 Set	Dyno-Pak 10 Sets	Packaged 1 Set	Dyno-Pak 10 Sets	Packaged 1 Set	Packaged 1 Set	Packaged 1 Set
Chev. Perf. DRCE-1 · AJPE 481-X — 2.32" Round			Fits headers with 2.5" primary tube O.D.				
	174080	74080-10	274080	274080-10	—	4074	—
Chev. Perf. DRCE-2 & 3 — 2.32" Round			Fits headers with 2.5" primary tube O.D.				
	176080	76080-10	276080	276080-10	—	4176	—
AJPE 4.9" NHRA Pro Stock — 2.25" Round			Fits headers with 2.5" primary tube O.D.				
	115081	15081-10	215081	215081-10	—	4015	—
AJPE 5.0" Mountain Motor Pro Stock — 2.40" x 2.00" Oval			Gasket matches cylinder head exhaust port with 2.5" primary tube O.D.				
	155081	55081-10	255181	55181-10	—	—	—
Brodix PB 5000 — 2.25" Round			Fits Brodix PB, BP 5000 Series 5.0" with 2.5" primary tube O.D.				
	195085	95085-10	295185	295185-10	—	—	—
Sonny's 813 & Billet 5.0 — 2.50" Round			Fits Sonny's 813 & Billet 5.0" Bore Center Heads				
	140081	40081-10	240081	240081-10	—	4040	—
Sonny's 5.3 — 2.67" Round			Fits Sonny's 5.3" Bore Center Heads				
	143080	43080-10	243080	243080-10	—	4043	—
<b>Marine Derivatives</b>							
MerCruiser 454 — 2.00" Round			Fits only Mercury Marine MerCruiser 454 Unique bolt pattern				
	113187	113187-10	213187	213187-10	—	—	—

**Chevrolet 396-454 Big Block**  
**Accu-Seal Pro · Performance Head Gaskets**

Application	Image	Bore Opening	Compr. Thick.	Part Number	Description	Qty.
<b>1965-90</b> <b>V8</b> <b>MK IV</b> <b>396-454 ci</b> <b>6.5-7.4 L</b>		4.250"	.020"	5132520	Embossed steel shim construction.	1
		4.320"	.020"	5133220		1

**Chevrolet 396-572 Big Block**  
**MLS Spartan · Performance Head Gaskets**

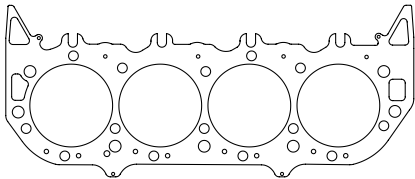
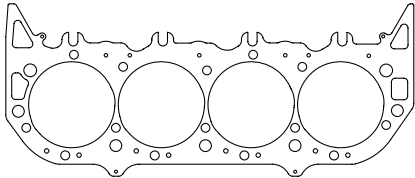
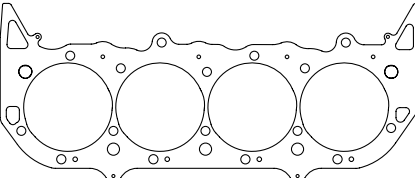
Application	Image	Bore Opening	Compr. Thick.	Part Number	Description	Qty.	
<b>1965-90</b> <b>MK IV</b> <b>396-454 ci</b> <b>6.5-7.4 L</b>	 Accommodates 1/2" head studs	4.375"	.028"	M133728	MLS embossed stainless steel construction.	1	
			.039"	M133739		1	
			.051"	M133751		1	
		4.540"	.028"	M135428		1	
			.039"	M135439		1	
			.051"	M135451		1	
			.075"	M135475		1	
			4.630"	.028"		M136328	1
				.039"		M136339	1
				.045"		M136345	1
.051"	M136351			1			
.059"	M136359			1			
<b>1990-Up</b> <b>GEN V-VI</b> <b>454-572 ci</b> <b>7.4-9.4 L</b>		4.375"	.039"	M143739	MLS embossed stainless steel construction.	1	
		4.540"	.039"	M145439		1	
		4.630"	.039"	M146339		1	
<p><b>Marine Use:</b> stainless steel construction, all MLS Spartan head gaskets are suitable for use in marine applications.</p>							

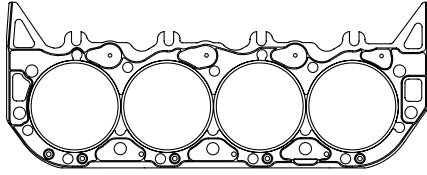
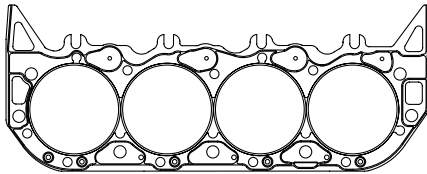

**Chevrolet 454-572+ Big Block**  
**Vulcan Cut-Ring · Performance Head Gaskets**

Application	Image	Bore Opening	Compr. Thick.	Part Number	Description	Qty.
<b>1965-90 MK IV 427-572+ ci 7.4-9.4+ L</b>	 <p>Accommodates 1/2" head studs.</p>	4.540"	0.039"	CR135439	Stainless steel Cut-Ring combustion seals.  Composite gasket body construction.	1
			0.051"	CR135451		1
			0.059"	CR135459		1
		4.630"	0.039"	CR136339		1
			0.051"	CR136351		1
			0.059"	CR136359		1

**Chevrolet Mark IV BBC · 4.840" Bore Center**

**Pro-Copper  
Racing Head Gaskets**

For use with o-rings & sealant

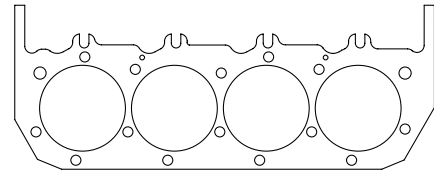
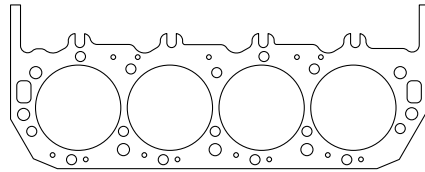

No water holes: use suffix "NW"

Bore Opening	Thickness								Qty.
	.021"	.032"	.043"	.050"	.062"	.072"	.080"	.093"	
4.250" round	P132521	P132532	P132543	P132550	P132562	P132572	P132580	P132593	1
4.320" round	P133221	P133232	P133243	P133250	P133262	P133272	P133280	P133293	1
4.380" round	P133821	P133832	P133843	P133850	P133862	P133872	P133880	P133893	1
4.440" round	P134421	P134432	P134443	P134450	P134462	P134472	P134480	P134493	1
4.520" round	P135221	P135232	P135243	P135250	P135262	P135272	P135280	P135293	1
4.570" round	P135721	P135732	P135743	P135750	P135762	P135772	P135780	P135793	1
4.630" round	P136221	P136232	P136243	P136250	P136262	P136272	P136280	P136293	1

**Titan  
Copper Racing Head Gaskets**

Sealed coolant passages, for use with o-rings & sealant

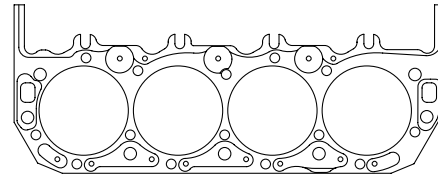

Bore Opening	Thickness								Qty.
	.021"	.032"	.043"	.050"	.062"	.072"	.080"	.093"	
4.250" round	-	T132532	T132543	T132550	T132562	T132572	T132580	T132593	1
4.320" round	-	T133232	T133243	T133250	T133262	T133272	T133280	T133293	1
4.380" round	-	T133832	T133843	T133850	T133862	T133872	T133880	T133893	1
4.440" round	-	T134432	T134443	T134450	T134462	T134472	T134480	T134493	1
4.520" round	-	T135232	T135243	T135250	T135262	T135272	T135280	T135293	1
4.570" round	-	T135732	T135743	T135750	T135762	T135772	T135780	T135793	1
4.630" round	-	T136232	T136243	T136250	T136262	T136272	T136280	T136293	1

**ICS  
Copper Racing Head Gaskets**

Sealed coolant passages, integral combustion o-ring

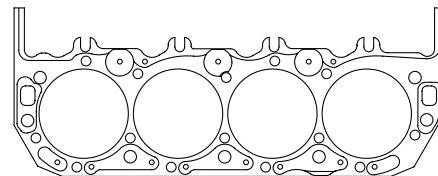

Bore Opening	Thickness								Qty.
	.021"	.032"	.043"	.050"	.062"	.072"	.080"	.093"	
4.250–4.440"	-	-	No Fit: BBC combustion chambers extend past 4.440" round						-
4.520" round	-	-	S135243	S135250	S135262	S135272	S135280	S135293	1
4.570" round	-	-	S135743	S135750	S135762	S135772	S135780	S135793	1
4.630" round	-	-	S136243	S136250	S136262	S136272	S136280	S136293	1

**NOTE**, Pro-Copper, Titan, & ICS: 4.250"–4.570" bore openings will accommodate 1/2" Head Studs

**BBC GEN V-VI • 454-572 ci • 4.840" Bore Center**

**Pro-Copper  
Racing Head Gaskets**

For use with o-rings & sealant

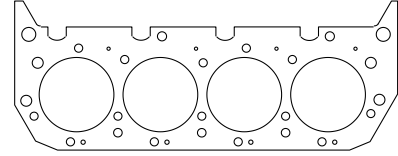

Bore Opening	Thickness								Qty.
	.021"	.032"	.043"	.050"	.062"	.072"	.080"	.093"	
4.320" round	P143221	P143232	P143243	P143250	P143262	P143272	P143280	P143293	1
4.380" round	P143821	P143832	P143843	P143850	P143862	P143872	P143880	P143893	1
4.440" round	P144421	P144432	P144443	P144450	P144462	P144472	P144480	P144493	1
4.520" round	P145221	P145232	P145243	P145250	P145262	P145272	P145280	P145293	1
4.570" round	P145721	P145732	P145743	P145750	P145762	P145772	P145780	P145793	1
4.630" round	P146221	P146232	P146243	P146250	P146262	P146272	P146280	P146293	1

**Titan  
Copper Racing Head Gaskets**

Sealed coolant passages, for use with o-rings & sealant

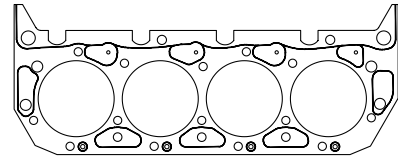

Bore Opening	Thickness								Qty.
	.021"	.032"	.043"	.050"	.062"	.072"	.080"	.093"	
4.320" round	–	T143232	T143243	T143250	T143262	T143272	T143280	T143293	1
4.380" round	–	T143832	T143843	T143850	T143862	T143872	T143880	T143893	1
4.440" round	–	T144432	T144443	T144450	T144462	T144472	T144480	T144493	1
4.520" round	–	T145232	T145243	T145250	T145262	T145272	T145280	T145293	1
4.570" round	–	T145732	T145743	T145750	T145762	T145772	T145780	T145793	1
4.630" round	–	T146232	T146243	T146250	T146262	T146272	T146280	T146293	1

**ICS  
Copper Racing Head Gaskets**

Sealed coolant passages, integral combustion o-ring

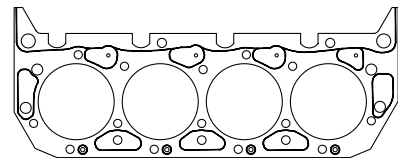

Bore Opening	Thickness								Qty.
	.021"	.032"	.043"	.050"	.062"	.072"	.080"	.093"	
4.320"-4.440" round	–	–	No Fit: BBC combustion chambers extend past 4.440" round						–
4.520" round	–	–	S145243	S145250	S145262	S145272	S145280	S145293	1
4.570" round	–	–	S145743	S145750	S145762	S145772	S145780	S145793	1
4.630" round	–	–	S146243	S146250	S146262	S146272	S146280	S146293	1

**BBC Racing Derivatives • AJPE 481-X • 4.840" Bore Center**

**Pro-Copper  
Racing Head Gaskets**

For use with o-rings & sealant

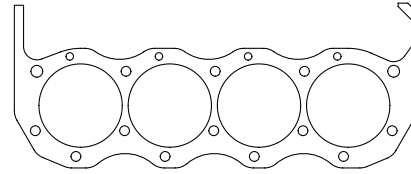

Bore Opening	Thickness								Qty.
	.043"	.050"	.062"	.072"	.080"	.093"	.100"	.110"	
4.380" round	P743843	P743850	P743862	P743872	P743880	P743893	–	–	1
4.440" round	P744443	P744450	P744462	P744472	P744480	P744493	–	–	1
4.470" round	P744743	P744750	P744762	P744772	P744780	P744793	–	–	1
4.520" round	P745243	P745250	P745262	P745272	P745280	P745293	–	–	1

**BBC Racing Derivatives • DRCE-1 • 4.840" Bore Center**

**Pro-Copper  
Racing Head Gaskets**

For use with o-rings & sealant

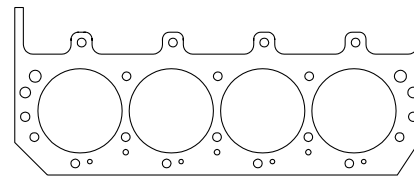

Bore Opening	Thickness								Qty.
	.043"	.050"	.062"	.072"	.080"	.093"	.100"	.110"	
4.520" round	P775243	P775250	P775262	P775272	P775280	P775293	–	–	1
4.570" round	P775743	P775750	P775762	P775772	P775780	P775793	–	–	1
4.630" round	P776243	P776250	P776262	P776272	P776280	P776293	–	–	1

**BBC Racing Derivatives • AJPE NHRA Pro Stock • 4.9" Bore Center**

**Pro-Copper  
Racing Head Gaskets**

For use with o-rings & sealant

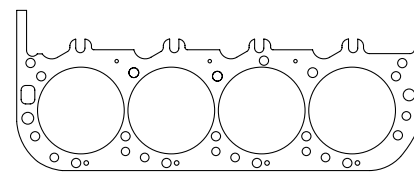

Bore Opening	Thickness								Qty.
	.043"	.050"	.062"	.072"	.080"	.093"	.100"	.110"	
4.520" round	P155243	P155250	P155262	P155272	P155280	P155293	–	–	1
4.570" round	P155743	P155750	P155762	P155772	P155780	P155793	–	–	1
4.630" round	P156243	P156250	P156262	P156272	P156280	P156293	–	–	1
4.700" round	P157043	P157050	P157062	P157072	P157080	P157093	–	–	1

**BBC Racing Derivatives • BBC Bolt Pattern • 4.9" Bore Center**

**Pro-Copper  
Racing Head Gaskets**

For use with o-rings & sealant

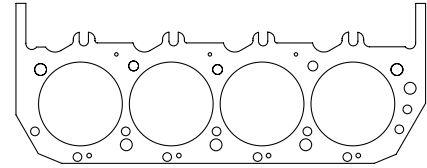

Bore Opening	Thickness								Qty.
	.043"	.050"	.062"	.072"	.080"	.093"	.100"	.110"	
4.520" round	P165243	P165250	P165262	P165272	P165280	P165293	-	-	1
4.570" round	P165743	P165750	P165762	P165772	P165780	P165793	-	-	1
4.630" round	P166243	P166250	P166262	P166272	P166280	P166293	-	-	1
4.700" round	P167043	P167050	P167062	P167072	P167080	P167093	-	-	1

**BBC Racing Derivatives • DRCE-2 & 3 • 4.9" Bore Center**

**Pro-Copper  
Racing Head Gaskets**

For use with o-rings & sealant

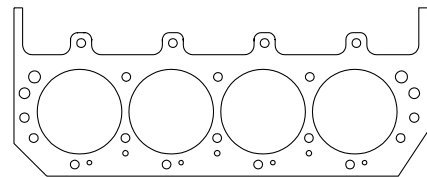

Bore Opening	Thickness								Qty.
	.043"	.050"	.062"	.072"	.080"	.093"	.100"	.110"	
4.520" round	P765243	P765250	P765262	P765272	P765280	P765293	-	-	1
4.570" round	P765743	P765750	P765762	P765772	P765780	P765793	-	-	1
4.630" round	P766243	P766250	P766262	P766272	P766280	P766293	-	-	1
4.700" round	P767043	P767050	P767062	P767072	P767080	P767093	-	-	1

**BBC Racing Derivatives • BBC Bolt Pattern • 5.0" Bore Center**

**Pro-Copper  
Racing Head Gaskets**

For use with o-rings & sealant

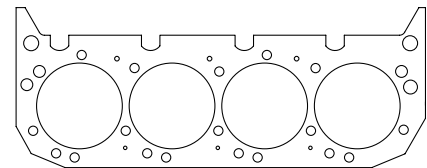

Bore Opening	Thickness								Qty.
	.043"	.050"	.062"	.072"	.080"	.093"	.100"	.110"	
4.630" round	P216243	P216250	P216262	P216272	P216280	P216293	-	-	1
4.700" round	P217043	P217050	P217062	P217072	P217080	P217093	-	-	1
4.770" round	P217743	P217750	P217762	P217772	P217780	P217793	-	-	1

**BBC Racing Derivatives · Olds Bolt Pattern · 5.0" Bore Center**

**Pro-Copper  
Racing Head Gaskets**

For use with o-rings & sealant

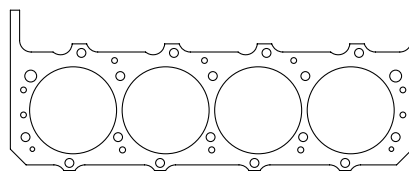

Bore Opening	Thickness								Qty.
	.043"	.050"	.062"	.072"	.080"	.093"	.100"	.110"	
4.630" round	P756243	P756250	P756262	P756272	P756280	P756293	—	—	1
4.700" round	P757043	P757050	P757062	P757072	P757080	P757093	—	—	1
4.770" round	P757743	P757750	P757762	P757772	P757780	P757793	—	—	1

**BBC Racing Derivatives · Fulton · 5.0" Bore Center**

**Pro-Copper  
Racing Head Gaskets**

For use with o-rings & sealant

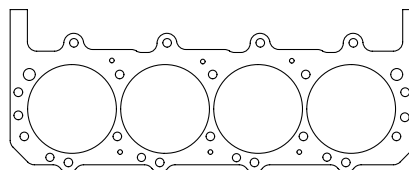

Bore Opening	Thickness								Qty.
	.043"	.050"	.062"	.072"	.080"	.093"	.100"	.110"	
4.630" round	P506243	P506250	P506262	P506272	P506280	P506293	—	—	1
4.700" round	P507043	P507050	P507062	P507072	P507080	P507093	—	—	1
4.770" round	P507743	P507750	P507762	P507772	P507780	P507793	—	—	1

**BBC Racing Derivatives · Sonny's 813 · 5.0" Bore Center**

**Pro-Copper  
Racing Head Gaskets**

For use with o-rings & sealant

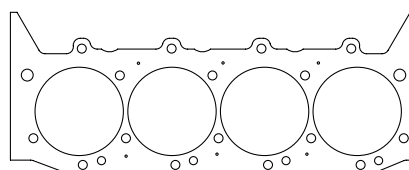

Bore Opening	Thickness								Qty.
	.043"	.050"	.062"	.072"	.080"	.093"	.100"	.110"	
4.630" round	P406243	P406250	P406262	P406272	P406280	P406293	—	—	1
4.700" round	P407043	P407050	P407062	P407072	P407080	P407093	—	—	1
4.770" round	P407743	P407750	P407762	P407772	P407780	P407793	—	—	1

**BBC Racing Derivatives · Sonny's Billet 5.0" Bore Center**

**Pro-Copper  
Racing Head Gaskets**

For use with o-rings & sealant

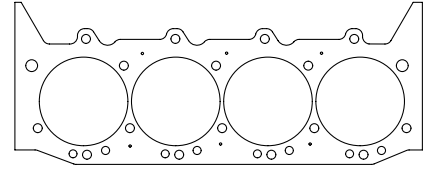

Bore Opening	Thickness								Qty.
	.043"	.050"	.062"	.072"	.080"	.093"	.100"	.110"	
4.630" round	P456243	P456250	P456262	P456272	P456280	P456293	-	-	1
4.700" round	P457043	P457050	P457062	P457072	P457080	P457093	-	-	1
4.770" round	P457743	P457750	P457762	P457772	P457780	P457793	-	-	1

P45\_\_\_\_\_ supersedes P40\_\_\_\_ B

**BBC Racing Derivatives · AJPE 5.0" Bore Center Pro Street**

**Pro-Copper  
Racing Head Gaskets**

For use with o-rings & sealant

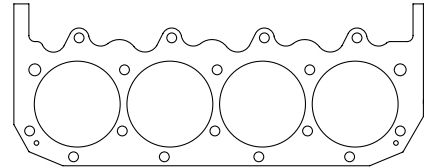

Bore Opening	Thickness								Qty.
	.043"	.050"	.062"	.072"	.080"	.093"	.100"	.110"	
4.630" round	P556243	P556250	P556262	P556272	P556280	P556293	-	-	1
4.700" round	P557043	P557050	P557062	P557072	P557080	P557093	-	-	1
4.770" round	P557743	P557750	P557762	P557772	P557780	P557793	-	-	1

**BBC Racing Derivatives · Brodix PB 5000 Series 5.0" Bore Center**

**Pro-Copper  
Racing Head Gaskets**

For use with o-rings & sealant

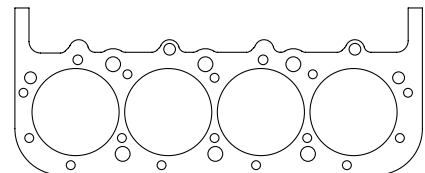

Bore Opening	Thickness								Qty.
	.043"	.050"	.062"	.072"	.080"	.093"	.100"	.110"	
4.630" round	P956243	P956250	P956262	P956272	P956280	P956293	-	-	1
4.700" round	P957043	P957050	P957062	P957072	P957080	P957093	-	-	1
4.770" round	P957743	P957750	P957762	P957772	P957780	P957793	-	-	1

**BBC Racing Derivatives • EPD Olds 5.0" Bore Center**

**Pro-Copper  
Racing Head Gaskets**

For use with o-rings & sealant

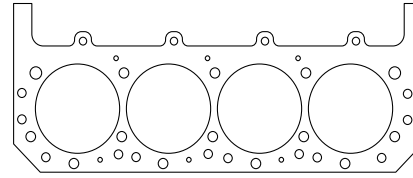

Bore Opening	Thickness								Qty.
	.043"	.050"	.062"	.072"	.080"	.093"	.100"	.110"	
4.700" round	P427043	P427050	P427062	P427072	P427080	P427093	—	—	1
4.770" round	P427743	P427750	P427762	P427772	P427780	P427793	—	—	1
4.800" round	P428043	P428050	P428062	P428072	P428080	P428093	—	—	1

**BBC Racing Derivatives • Sonny's 5.3" Bore Center**

**Pro-Copper  
Racing Head Gaskets**

For use with o-rings & sealant

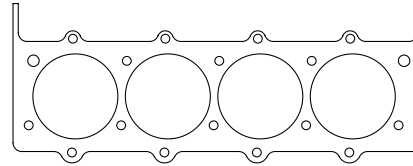

Bore Opening	Thickness								Qty.
	.043"	.050"	.062"	.072"	.080"	.093"	.100"	.110"	
4.800" round	P438043	P438050	P438062	P437772	P438080	P438093	—	—	1
4.830" round	P438343	P438350	P438362	P438372	P438380	P438393	—	—	1
4.870" round	P438743	P438750	P438762	P438772	P438780	P438793	—	—	1
5.020" round	P430243	P430250	P430262	P430272	P430280	P430293	—	—	1

**BBC Racing Derivatives • Sonny's 5.4" Bore Center**

**Pro-Copper  
Racing Head Gaskets**

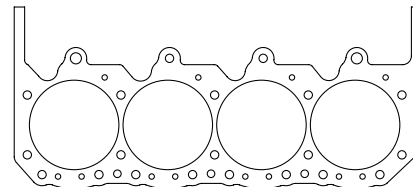

For use with o-rings & sealant



Bore Opening	Thickness								Qty.
	.043"	.050"	.062"	.072"	.080"	.093"	.100"	.110"	
4.830" round	P448343	P448350	P448362	P448372	P448380	P448393	—	—	1
4.870" round	P448743	P448750	P448762	P448772	P448780	P448793	—	—	1
5.020" round	P440243	P440250	P440262	P440272	P440280	P440293	—	—	1
5.160" round	P441643	P441650	P441662	P441672	P441680	P441693	—	—	1

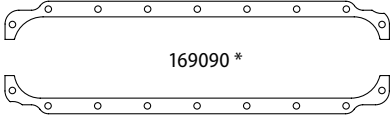

**Chrysler V8 273-360 LA Small Block · Short Block Gaskets & Seals**

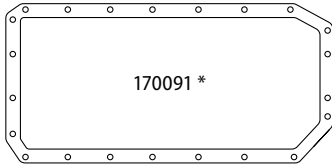
Application	Oil Pan Gasket Set	Timing Cover Gasket Set	Front Cover Gasket Set TC · WP · FP	Water Pump Gasket Set	Fuel Pump Gasket	Water Outlet Gasket	Timing Cover Oil Seal	Rear Main Oil Seal	Qty.
<b>1964-91</b> <b>273, 318,</b> <b>340 ci</b>  <b>&amp;</b>  <b>1971-92</b> <b>360 ci</b>	 <p><b>Accu-Seal E</b> standard gasket materials, nitrile or silicone seals.</p> <p>* OEM-style 6-pc set w/ rubberized fiber rails &amp; end-seals (end seals not pictured). Kit includes oil pan end-seals needed for both 273-340 <b>and</b> 360 engines.</p>								
	169090 * <i>Fits 273-340 &amp; 360</i>	16903	16900	16901	11106 <i>supersedes 16906</i>	16908	16902	16904 <i>Fits 273-340</i>	1 Set
								16905 <i>Fits 360</i>	
69090-10 * <i>Fits 273-340 &amp; 360</i>	—	6900-10	6901-10	1106-10 <i>supersedes 6906-10</i>	6908-10	6902-10	6904-10 <i>Fits 273-340</i>	Dyno-Pak 10 Sets	
							6905-10 <i>Fits 360</i>		
<b>1993-Up</b> <b>5.2-5.9 L</b> <b>Magnum</b>  <i>Also fits Δ</i> <b>1971-92</b> <b>360 ci</b>	<p><b>Accu-Seal E</b> standard gasket materials, nitrile or silicone seals.</p>								
	—	16903	16900	16901	11106 <i>supersedes 16906</i>	16908	16902	—	1 Set
		—	6900-10	6901-10	1106-10 <i>supersedes 6906-10</i>	6908-10	6902-10	—	Dyno-Pak 10 Sets
	 <p><b>Accu-Seal Pro</b> premium gasket materials, FKM seals, molded water outlet.</p> <p>† 1-pc molded silicone. Steel backbone &amp; crush limiters. Δ Installation of molded oil pan gasket on early 360 requires use of '92-Up Magnum timing cover.</p>								
	269091 †Δ	—	—	—	—	—	26902	—	1 Set
269091-10 †Δ	—	—	—	—	—	26902-10	—	Dyno-Pak 10 Sets	
<b>Mopar A8</b> <b>Aluminum</b> <b>Block</b>	 <p><b>Accu-Seal E</b> standard gasket materials, nitrile or silicone seals.</p>								
	170091 *	—	—	—	—	—	—	—	1 Set
	170091-10 *	—	—	—	—	—	—	—	Dyno-Pak 10 Sets
	<p><b>Accu-Seal Pro</b> premium gasket materials, FKM seals, molded water outlet.</p> <p>† Severe Duty™, .093" thick PTFE-coated, steel-core material.</p>								
	270091 †	—	—	—	—	—	—	—	1 Set
	270091-10 †	—	—	—	—	—	—	—	Dyno-Pak 10 Sets

**NEW!**  
— SEE P.8 —

## Chrysler V8 273-360 LA Small Block

### SBBK – Short Block Base Kit





Provides remaining gaskets & seals common to the engine type, regardless of customization.

Application	SBBK Gasket/Oil Seal Kit	Contents of Kit	
1967-91 318-340 ci 5.2-5.6 L	36903	<b>Includes:</b> Timing Cover · Water Pump · Fuel Pump · Water Outlet Gasket · Timing Cover Seal · 2-pc Rear Main Seal	
1971-92 360 ci 5.9 L	36904	<b>Includes:</b> Timing Cover · Water Pump · Fuel Pump · Water Outlet Gasket · Timing Cover Seal · 2-pc Rear Main Seal	



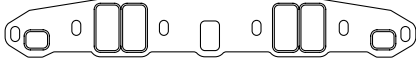

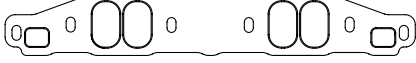
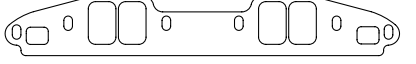
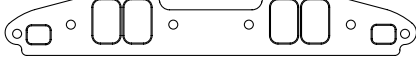
## Chrysler V8 273-360 LA Small Block · Valve Cover Gaskets

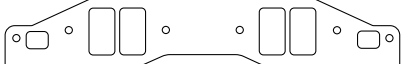
Application	Molded Silicone Rubber	Hi-Density Cork 5/16" Thick	Tuff-Bak Laminated Cork		Steel Core PTFE-Coated .093" Thick (3/32")	Qty.
			1/8" Thick	1/4" Thick		
Street / Strip			Racing / Hi-Vac		Severe Duty™	
1964-92 273-360 ci 5.2-5.9 L All Race Heads Thru W9			5-bolt, 2 over 3 perimeter pattern.			
	-	-	269175	269176	269178	1 Set
	-	-	69175-10	69176-10	69178-10	Dyno-Pak 10 Sets
1993-03 5.2-5.9 L Magnum Stock Head			10-bolt, 5 over 5 perimeter pattern.			
	-	-	269171	269172	269179	1 Set
	-	-	69171-10	69172-10	69179-10	Dyno-Pak 10 Sets

**Chrysler V8 273-410 LA Small Block · Intake Gaskets**

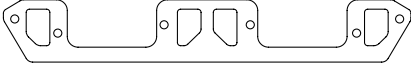
Application — Port Size	Thickness	Accu-Seal E Standard Material		Accu-Seal Pro · Premium Materials	
		Packaged 1 Set	Dyno-Pak · 10 Sets	Packaged 1 Set	Dyno-Pak · 10 Sets
<b>1964-90</b> <b>2 Barrel</b> <b>273-318 ci</b> <b>4.5-5.2 L</b> — <b>1.05" x 2.18"</b> <b>Rectangle</b>	 <p>Fits stock iron heads from 1964 to 1990. — † Silicone Bead Sealed Ports.</p>				
	.062"	169101	69101-10	269101 †	269101-10 †
	.120"	169106	—	—	
<b>1970-03</b> <b>4 Barrel &amp; Magnum</b> <b>318-360 ci</b> <b>5.2-5.9 L</b> — <b>1.17" x 2.27"</b> <b>Rectangle</b>	 <p>Fits 4 barrel heads from 1970 &amp; later. — † Silicone Bead Sealed Ports.</p>				
	.062"	169104	69104-10	269104 †	269104-10 †
	.120"	169107	—	—	
<b>Magnum Ported</b> <b>360 ci</b> <b>5.9 L</b> — <b>2.25" x 2.40"</b> <b>Rectangle</b>	 <p>Fits Magnum cylinder heads with modified ports.</p>				
	.062"	169112	69112-10	269112	269112-10
<b>Mopar W2</b> <b>360 ci</b> <b>5.9 L</b> — <b>1.45" x 2.30"</b> <b>Oval</b>	 <p>Also fits Indy CNC Oval Port. — † Silicone Bead Sealed Ports.</p>				
	.062"	169102	69102-10	269102 †	269102-10 †
	.120"	169103	—	Silicone Bead Sealed Ports	
<b>Indy 360-1</b> <b>318-360 ci</b> <b>5.2-5.9 L</b> — <b>1.36" x 2.16"</b> <b>Rectangle</b>	 <p>Fits Indy 360-1 as delivered with CNC ports by Indy.</p>				
	.062"	169111	69111-10	269111	269111-10
<b>Indy 360-2</b> <b>318-360 ci</b> <b>5.2-5.9 L</b> — <b>1.44" x 2.23"</b> <b>Rectangle</b>	 <p>Fits Indy 360-2 as delivered with CNC ports by Indy.</p>				
	.062"	169110	69110-10	269110	269110-10
<b>Mopar W7 - W8</b> <b>Race Heads</b> <b>318-360 ci</b> <b>5.2-5.9 L</b> — <b>1.40" x 2.15"</b> <b>Rectangle</b>	 <p>Fits Mopar W7 &amp; W8 heads.</p>				
	.062"	169105	69105-10	269105	269105-10
	.120"	169108	—	—	—
<b>Mopar W9 Raised Port</b> <b>Trim-to-Fit</b> <b>360-410 ci</b> <b>5.2-5.9 L</b> — <b>Rectangle</b>	 <p>Gasket includes water and intake ports as cast in W9RP semi-finished head.</p>				
	.062"	169109	69109-10	269109	269109-10

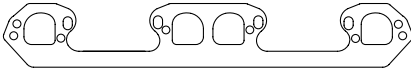
**Chrysler V8 273-410 LA Small Block · Exhaust Gaskets**

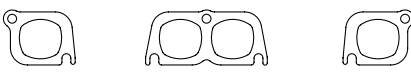
Application — Port Size	Accu-Seal E		Accu-Seal Pro		Graph-Form	Pro-Copper			
	Standard Material .062"		Premium Material .062"		Hi-Density Graphite .150"	Embossed .043"	Flat-Annealed .062"		
	Packaged 1 Set	Dyno-Pak 10 Sets	Packaged 1 Set	Dyno-Pak 10 Sets	Packaged 1 Set	Packaged 1 Set	Packaged 1 Set		
<b>2-Barrel Cyl. Heads</b> 273-360 ci 4.5-5.9 L — 1.12" x 1.65" Irregular			Stock bolt pattern, lower port corners have prominent angle.					-	-
<b>4-Barrel Cyl. Heads</b> 318-360 ci 5.2-5.9 L — 1.10" x 1.70" Irregular			Stock bolt pattern, lower port corners have prominent angle.					4069	E69186
<b>1993-03 Magnum</b> 318-360 ci 5.2-5.9 L — 1.20" x 1.52" Irregular			Stock bolt pattern, lower port corners have slight angle.					4169	-
<b>Racing Derivatives</b>									
<b>Mopar W2-W5-W7</b> — 1.50" x 1.46" D-Port			Fits Mopar W2, W5, W7 as cast, gasket has dual bolt patterns for both stock & W2.					-	-
<b>Mopar W2-W5-W7 Ported Head</b> — 1.88" Round			Fits Mopar W2, W5, W7 race-ported heads & seals up to 2" headers.					-	-
<b>Mopar W8-W9 Race Heads</b> — 1.80" x 1.75" Oval			7 bolts, separated to allow for injectors, fits ported heads and seals up to 2" headers. Set includes 6 individual pieces.					-	-

**Chrysler V8 273-360 LA Small Block**  
**MLS Spartan · Performance Head Gaskets**

Application	Image	Bore Opening	Compr. Thick.	Part Number	Description	Qty.
1964-92 273-360 ci 4.5-5.9 L		4.080"	.039"	M690839	MLS embossed stainless steel construction.	1
1967-92 318-360 ci 5.2-5.9 L		4.126"	.039"	M691239		1
<p><b>Marine Use:</b> stainless steel construction, all MLS Spartan head gaskets are suitable for use in marine applications.</p>						

**Chrysler V8 LA Small Block • 273-360 ci • 4.5-5.9 L**

**Pro-Copper  
Racing Head Gaskets**

For use with o-rings & sealant

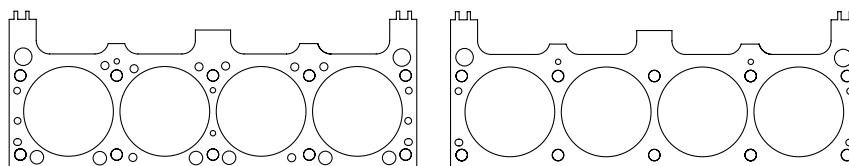

No water holes: use suffix "NW"

Bore Opening	Thickness								Qty.
	.021"	.032"	.043"	.050"	.062"	.072"	.080"	.093"	
4.060" round	P690621L P690621R	P690632L P690632R	P690643L P690643R	P690650L P690650R	P690662L P690662R	P690672L P690672R	P690680L P690680R	P690693L P690693R	1
4.160" round	P691521L P691521R	P691532L P691532R	P691543L P691543R	P691550L P691550R	P691562L P691562R	P691572L P691572R	P691580L P691580R	P691593L P691593R	1
4.200" round	P692021L P692021R	P692032L P692032R	P692043L P692043R	P692050L P692050R	P692062L P692062R	P692072L P692072R	P692080L P692080R	P692093L P692093R	1

**Titan  
Copper Racing Head Gaskets**

Sealed coolant passages, for use with o-rings & sealant

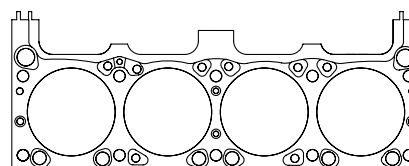

Bore Opening	Thickness								Qty.
	.021"	.032"	.043"	.050"	.062"	.072"	.080"	.093"	
4.060" round	—	T690632L T690632R	T690643L T690643R	T690650L T690650R	T690662L T690662R	T690672L T690672R	T690680L T690680R	T690693L T690693R	1
4.160" round	—	T691532L T691532R	T691543L T691543R	T691550L T691550R	T691562L T691562R	T691572L T691572R	T691580L T691580R	T691593L T691593R	1
4.200" round	—	T692032L T692032R	T692043L T692043R	T692050L T692050R	T692062L T692062R	T692072L T692072R	T692080L T692080R	T692093L T692093R	1

**ICS  
Copper Racing Head Gaskets**

Sealed coolant passages, integral combustion o-ring

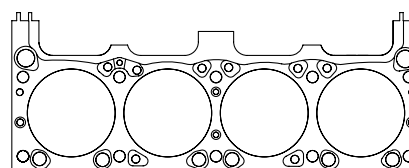

Bore Opening	Thickness								Qty.
	.021"	.032"	.043"	.050"	.062"	.072"	.080"	.093"	
4.060" round	—	—	S690643L S690643R	S690650L S690650R	S690662L S690662R	S690672L S690672R	S690680L S690680R	S690693L S690693R	1
4.160" round	—	—	S691543L S691543R	S691550L S691550R	S691562L S691562R	S691572L S691572R	S691580L S691580R	S691593L S691593R	1
4.200" round	—	—	S692043L S692043R	S692050L S692050R	S692062L S692062R	S692072L S692072R	S692080L S692080R	S692093L S692093R	1

**Chrysler LA Racing Derivatives · Mopar A8 Aluminum Small Block**

**Pro-Copper  
Racing Head Gaskets**

For use with o-rings & sealant

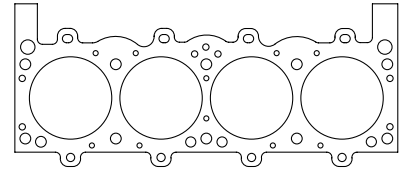

Bore Opening	Thickness								Qty.
	.021"	.032"	.043"	.050"	.062"	.072"	.080"	.093"	
4.060" round	P700621L P700621R	P700632L P700632R	P700643L P700643R	P700650L P700650R	P700662L P700662R	P700672L P700672R	P700680L P700680R	P700693L P700693R	1
4.160" round	P701521L P701521R	P701532L P701532R	P701543L P701543R	P701550L P701550R	P701562L P701562R	P701572L P701572R	P701580L P701580R	P701593L P701593R	1
4.200" round	P702021L P702021R	P702032L P702032R	P702043L P702043R	P702050L P702050R	P702062L P702062R	P702072L P702072R	P702080L P702080R	P702093L P702093R	1

**Titan  
Copper Racing Head Gaskets**

Sealed coolant passages, for use with o-rings & sealant

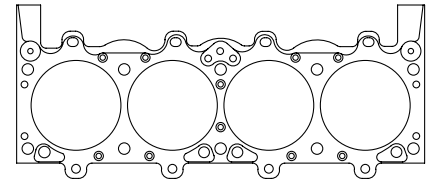

Bore Opening	Thickness								Qty.
	.021"	.032"	.043"	.050"	.062"	.072"	.080"	.093"	
4.060" round	—	T700632L T700632R	T700643L T700643R	T700650L T700650R	T700662L T700662R	T700672L T700672R	T700680L T700680R	T700693L T700693R	1
4.160" round	—	T701532L T701532R	T701543L T701543R	T701550L T701550R	T701562L T701562R	T701572L T701572R	T701580L T701580R	T701593L T701593R	1
4.200" round	—	T702032L T702032R	T702043L T702043R	T702050L T702050R	T702062L T702062R	T702072L T702072R	T702080L T702080R	T702093L T702093R	1

**ICS  
Copper Racing Head Gaskets**

Sealed coolant passages, integral combustion o-ring

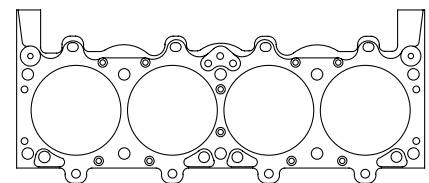

Bore Opening	Thickness								Qty.
	.021"	.032"	.043"	.050"	.062"	.072"	.080"	.093"	
4.060" round	—	—	S700643L S700643R	S700650L S700650R	S700662L S700662R	S700672L S700672R	S700680L S700680R	S700693L S700693R	1
4.160" round	—	—	S701543L S701543R	S701550L S701550R	S701562L S701562R	S701572L S701572R	S701580L S701580R	S701593L S701593R	1
4.200" round	—	—	S702043L S702043R	S702050L S702050R	S702062L S702062R	S702072L S702072R	S702080L S702080R	S702093L S702093R	1

**Chrysler LA Racing Derivatives • Mopar R5/P7 with 6-Bolt Pattern**

**Pro-Copper  
Racing Head Gaskets**

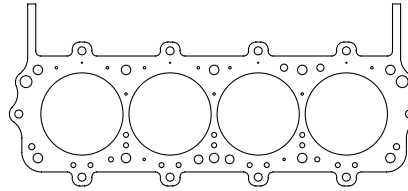

For use with o-rings & sealant



Bore Opening	Thickness								Qty.
	.021"	.032"	.043"	.050"	.062"	.072"	.080"	.093"	
4.160" round	P731621L P731621R	P731632L P731632R	P731643L P731643R	P731650L P731650R	P731662L P731662R	P731672L P731672R	P731680L P731680R	P731693L P731693R	1
4.200" round	P732021L P732021R	P732032L P732032R	P732043L P732043R	P732050L P732050R	P732062L P732062R	P732072L P732072R	P732080L P732080R	P732093L P732093R	1
4.250" round	P732521L P732521R	P732532L P732532R	P732543L P732543R	P732550L P732550R	P732562L P732562R	P732572L P732572R	P732580L P732580R	P732593L P732593R	1

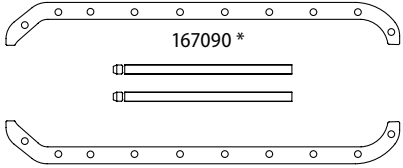

**Chrysler V8 331-392 · Early Hemi · Short Block Gaskets & Seals**

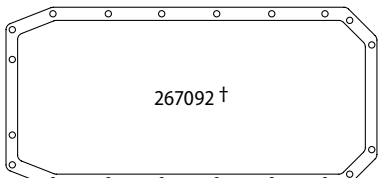
Application	Oil Pan Gasket Set	Timing Cover Gasket Set	Front Cover Gasket Set TC · WP · FP	Water Pump Gasket Set	Fuel Pump Gasket	Water Outlet Gasket	Timing Cover Oil Seal	Rear Main Oil Seal	Qty.
<b>1951-58 GEN 1 Hemi 331-392 ci 5.4-6.4 L</b>	 <p style="text-align: center;">167090 *</p> <p style="text-align: right;"><b>Accu-Seal E</b> standard gasket materials, nitrile or silicone seals.</p> <p style="text-align: right;">* OEM-style 4-pc set w/ rubberized fiber rails.</p>								
	167090 *	16703	16700	16701	11106 <i>supersedes 16706</i>	16708	16702	16907 <i>Fits 331 &amp; 354 only</i>	1 Set
	67090-10 *	—	6700-10	6701-10	1106-10 <i>supersedes 6706-10</i>	6708-10	6702-10	6907-10 <i>Fits 331 &amp; 354 only</i>	Dyno-Pak 10 Sets
	<p><b>Accu-Seal Pro</b> premium gasket materials.</p> <p>† 4-pc set • Severe Duty™, .093" thick PTFE-coated, steel-core material.</p>								
	267090 †	—	—	—	—	—	26702	—	1 Set
267090-10 †	—	—	—	—	—	26702-10	—	Dyno-Pak 10 Sets	
<b>392 Racing Derivatives</b>									
<b>Donovan 417 Aluminum Block</b>	 <p style="text-align: center;">167091 Δ 267091 †</p> <p style="text-align: right;"><b>Δ Accu-Seal E</b> standard gasket materials, nitrile or silicone seals.</p> <p style="text-align: right;">* 1-pc rubberized fiber material.</p>								
	167091 *	—	16700	—	—	—	16702	13405 Δ	1 Set
	67091-10 *	—	6700-10	—	—	—	6702-10	3405-10 Δ	Dyno-Pak 10 Sets
	<p><b>Accu-Seal Pro</b> premium gasket materials.</p> <p>† 1-pc • Severe Duty™, .093" thick PTFE-coated, steel-core material.</p>								
	267091 †	—	—	—	—	—	26702	—	1 Set
267091-10 †	—	—	—	—	—	26702-10	—	Dyno-Pak 10 Sets	
<b>Rodeck/ Emery Billet 392</b>	 <p style="text-align: center;">267092 †</p> <p style="text-align: right;"><b>Δ Accu-Seal E</b> standard gasket materials, nitrile or silicone seals.</p> <p style="text-align: right;"><b>Accu-Seal Pro</b> premium gasket materials.</p> <p style="text-align: right;">† 1-pc • Severe Duty™, .093" thick PTFE-coated, steel-core material.</p> <p style="text-align: right;">‡ FKM Material.</p>								
	267092 †	—	—	—	—	—	26702 ‡	13405 Δ	1 Set
	267092-10 †	—	—	—	—	—	26702-10 ‡	3405-10 Δ	Dyno-Pak 10 Sets

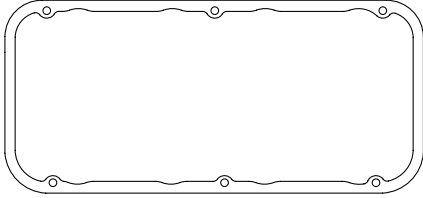
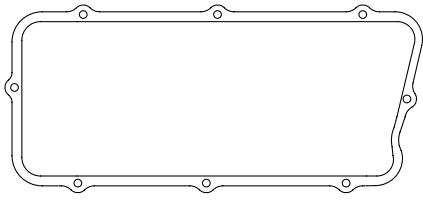
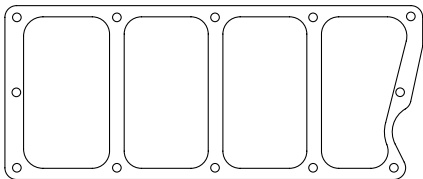
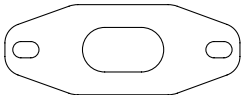

**Chrysler V8 331-392 · Early Hemi · Valve Cover Gaskets**

Application	Rubberized Fiber 3/16" Thick	Tuff-Bak Laminated Cork		Fuel Resistant Fiber 5/8" Thick	Steel Core PTFE-Coated .093" Thick (3/32")	Qty.		
		1/8" Thick	1/4" Thick					
	Street / Strip	Racing / Hi-Vac		Sportsman Racing	Severe Duty™			
<b>1951-58 GEN 1 Chrysler Hemi 331-392 ci 5.4-6.4 L</b> • <b>Donovan 417</b> • <b>AJPE Billet 392</b>			6 bolts, 3-over-3 pattern, includes notches for large valve springs					
			167076	267175	267176	267075	267077	1 Set
			67076-10	267175-10	267176-10	267075-10	267077-10	Dyno-Pak 10 Sets
<b>1951-58 GEN 1 Chrysler Hemi Valley Cover</b> • <b>331-392 ci 5.4-6.4 L</b>			8 bolts, fits stock iron blocks and stock pattern aftermarket blocks					
			-	-	-	167104	267104	1 Pc
			-	-	-	67104-10	267104-10	Dyno-Pak 10 Pcs
<b>392 Racing Derivatives</b>								
<b>Donovan 417 Valley Cover</b>			12 bolts, fits Donovan 417 only.					
			-	-	-	167106	267106	1 Pc
			-	-	-	67106-10	267106-10	Dyno-Pak 10 Pcs
<b>Universal Valve Cover Breather Gaskets</b>			2 bolts, standard shape fits all popular breathers. — * Meets NHRA breather gasket rules.					
			-	-	-	16604	26604 *	1 Set
			-	-	-	16604-10	26604-10 *	Dyno-Pak 10 Sets

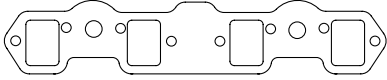
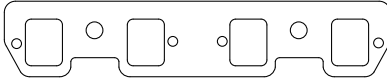
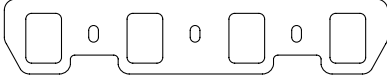
**Chrysler V8 331-392 · Intake Gaskets**

Application — Port Size	Thickness	Accu-Seal E Standard Material		Accu-Seal Pro · Premium Materials	
		Packaged 1 Set	Dyno-Pak · 10 Sets	Packaged 1 Set	Dyno-Pak · 10 Sets
<b>Stock Iron Heads</b> 1951-58 GEN 1 Hemi 331-392 ci 5.4-6.4 L — 1.50" x 2.05" Rectangle	 <p>Manifold gaskets only, fits most aftermarket head / manifold combinations</p>				
	.062"	167101	67101-10	267101	267101-10
	.120"	167106	-	-	-
<b>392 Racing Derivatives</b>					
<b>Smithberg 392</b> — 1.60" x 2.25" Rectangle	 <p>Stock bolt pattern with racing ports.                      † Perforated metal core material for forced induction.</p>				
	.062"	167102	67102-10	267102 †	267102-10 †
<b>AJPE Billet 392</b> — 1.60" x 2.25" Rectangle	 <p>Fits only AJPE Billet 392 Nostalgia Fuel heads, 3 bolts                      † Perforated metal core material for forced induction.</p>				
	.062"	167103	67103-10	267103 †	267103-10 †

**Chrysler V8 331-392 · Exhaust Gaskets**

Application — Port Size	Accu-Seal E		Accu-Seal Pro		Graph-Form	Pro-Copper	
	Standard Material .062"		Premium Material .062"		Hi-Density Graphite .150"	Embossed .043"	Flat-Annealed .062"
	Packaged 1 Set	Dyno-Pak 10 Sets	Packaged 1 Set	Dyno-Pak 10 Sets	Packaged 1 Set	Packaged 1 Set	Packaged 1 Set
1951-58 331-392 ci 5.4-6.4 L — 2.25" Round	 <p>Fits stock iron manifolds and stock pattern headers</p>						
	-	-	-	-	-	4067	E67186
<b>392 Racing Derivatives</b>							
<b>AJPE Billet 392 Nostalgia Fuel</b> — 2.50" x 1.90" Oval	 <p>Additional upper bolts between outer ports, embossed gasket matches oval exhaust port</p>						
	167080	167080-10	267080	267080-10	464080	4167	E67286

**Chrysler V8 331-392 · Vulcan Cut-Ring · Performance Head Gaskets**

Application	Image	Bore Opening	Compr. Thick.	Part Number	Description	Qty.
Gen 1 Hemi 331-392 ci 5.4-6.4 L		4.060"	0.043"	CR670643	Stainless steel Cut-Ring combustion seals.  Composite gasket body construction.	1

**Chrysler V8 Early Hemi · GEN 1 · 331-392 ci · 5.4-6.4 L**

**Pro-Copper  
Racing Head Gaskets**

For use with o-rings & sealant

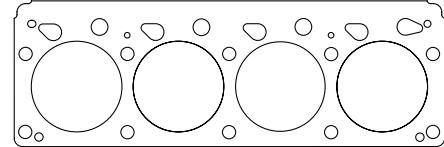
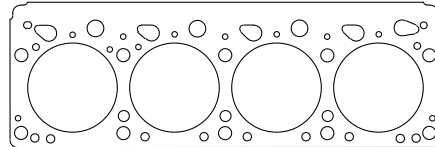

No water holes: use suffix "NW"

Bore Opening	Thickness								Qty.
	.021"	.032"	.043"	.050"	.062"	.072"	.080"	.093"	
4.010" round	–	P670032	P670043	P670050	P670062	P670072	P670080	P670093	1
4.060" round	–	P670632	P670643	P670650	P670662	P670672	P670680	P670693	1
4.160" round	–	P671532	P671543	P671550	P671562	P671572	P671580	P671593	1

**Titan  
Copper Racing Head Gaskets**

Sealed coolant passages, for use with o-rings & sealant

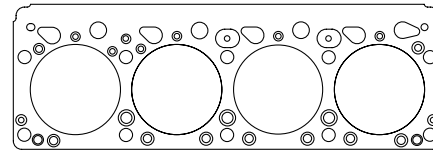

Bore Opening	Thickness								Qty.
	.021"	.032"	.043"	.050"	.062"	.072"	.080"	.093"	
4.010" round	–	T670032	T670043	T670050	T670062	T670072	T670080	T670093	1
4.060" round	–	T670632	T670643	T670650	T670662	T670672	T670680	T670693	1
4.160" round	–	T671532	T671543	T671550	T671562	T671572	T671580	T671593	1

**ICS  
Copper Racing Head Gaskets**

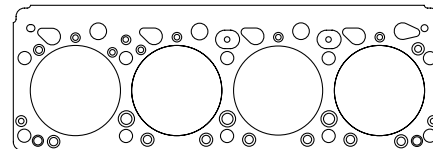

Sealed coolant passages, integral combustion o-ring



Bore Opening	Thickness								Qty.
	.021"	.032"	.043"	.050"	.062"	.072"	.080"	.093"	
4.010" round	–	–	S670043	S670050	S670062	S670072	S670080	S670093	1
4.060" round	–	–	S670643	S670650	S670662	S670672	S670680	S670693	1
4.160" round	–	–	S671543	S671550	S671562	S671572	S671580	S671593	1

**Note:** teardrop pushrod holes allow proper oil drain-back with AJPE Billet 392 heads, and are backward-compatible with all early hemi based engines.

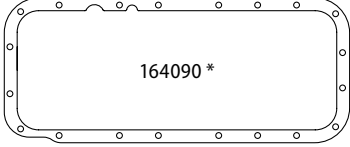
**Chrysler 383-440 Wedge · 426 Hemi · Short Block Gaskets & Seals**

Application	Oil Pan Gasket Set	Timing Cover Gasket Set	Front Cover Gasket Set TC · WP · FP	Water Pump Gasket Set	Fuel Pump Gasket	Water Outlet Gasket	Timing Cover Oil Seal	Rear Main Oil Seal	Oil Pump Gasket	Qty.
<b>1959-79 383-440ci 'RB' Wedge &amp; 1965-71 426 Hemi</b>	 <p style="text-align: center;">164090 *</p> <p style="text-align: right;"><b>Accu-Seal E</b> standard gasket materials, nitrile or silicone seals. * OEM-style • 1-pc gasket, rubberized fiber material.</p>									
	164090 *	16403	16400	16401	16406	16408	16402	16605	16607 <i>includes shaft o-ring</i>	1 Set
	64090-10 *	—	6400-10	6401-10	6406-10	6408-10	6402-10	6605-10	—	Dyno-Pak 10 Set
	<b>Accu-Seal Pro</b> premium gasket materials, FKM seals, molded water outlet. † OEM-style • 1-pc gasket • Severe Duty™, .093" thick PTFE-coated, steel-core material.									
	264090 †	—	—	—	—	—	26602	26605	—	1 Set
	264090-10 †	—	—	—	—	—	26602-10	26605-10	—	Dyno-Pak 10 Sets
	 <p style="text-align: center;">264092 Δ</p> <p style="text-align: right;"><b>Accu-Seal Pro</b> premium gasket materials, FKM seals. Δ 1-pc molded silicone. Steel backbone &amp; crush limiters.</p>									
	264092 Δ	—	—	—	—	—	26602	26605	—	1 Set
	264092-10 Δ	—	—	—	—	—	26602-10	26605-10	—	Dyno-Pak 10 Sets

**426 Hemi · Racing Derivatives**

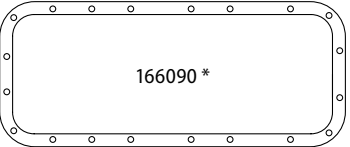
<b>AJPE / BAE / KB Racing Hemi</b>  Chrysler bolt pattern (no allowance for dipstick or oil pump)	 <p style="text-align: center;">166090 *</p> <p style="text-align: right;"><b>Accu-Seal E</b> standard gasket materials, nitrile or silicone seals. * 1-pc gasket, rubberized fiber material.</p>									
	166090 *	—	—	—	—	—	16402	16605	—	1 Set
	66090-10 *	—	—	—	—	—	6402-10	6605-10	—	Dyno-Pak 10 Sets
	<b>Accu-Seal Pro</b> premium gasket materials, FKM seals, molded water outlet. † 1-pc gasket • Severe Duty™, .093" thick PTFE-coated, steel-core material.									
	266091 †	—	—	—	—	—	26602	26605 <i>2.75" dia.</i>	—	1 Set
	266091-10 †	—	—	—	—	—	26602-10	26605-10 <i>23505 3.00" dia.</i>	—	Dyno-Pak 10 Sets

**426 Hemi - Racing Derivatives - Short Block Gaskets & Seals**

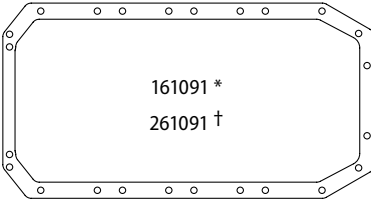
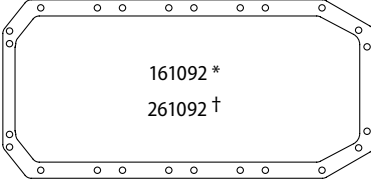
Application	Oil Pan Gasket Set	Timing Cover Gasket Set	Front Cover Gasket Set TC · WP · FP	Water Pump Gasket Set	Fuel Pump Gasket	Water Outlet Gasket	Timing Cover Oil Seal	Rear Main Oil Seal	Qty.
<b>TFX-92 Racing Hemi</b>  <b>Early wide pan, 10.5" width</b>	 <p>161091 * 261091 †</p> <p><b>Accu-Seal E</b> standard gasket materials, nitrile or silicone seals. * 1-pc gasket, rubberized fiber material.</p>								
	161091 *	-	-	-	-	-	16402	16605	1 Set
	61091-10 *	-	-	-	-	-	6402-10	6605-10	Dyno-Pak 10 Sets
	<p><b>Accu-Seal Pro</b> premium gasket materials, FKM seals, molded water outlet. † 1-pc gasket • Severe Duty™, .093" thick PTFE-coated, steel-core material.</p>								
	261091 †	-	-	-	-	-	26602	26605 2.75" dia. 23505 3.00" dia.	1 Set
261091-10 †	-	-	-	-	-	26602-10	26605-10 23505-10	Dyno-Pak 10 Sets	
<b>TFX-96 Racing Hemi</b>  <b>9.375" width</b>	 <p>161092 * 261092 †</p> <p><b>Accu-Seal E</b> standard gasket materials, nitrile or silicone seals. * 1-pc gasket, rubberized fiber material.</p>								
	161092 *	-	-	-	-	-	16402	16605	1 Set
	61092-10 *	-	-	-	-	-	6402-10	6605-10	Dyno-Pak 10 Sets
	<p><b>Accu-Seal Pro</b> premium gasket materials, FKM seals, molded water outlet. † 1-pc gasket • Severe Duty™, .093" thick PTFE-coated, steel-core material.</p>								
	261092 †	-	-	-	-	-	26602	26605 2.75" dia. 23505 3.00" dia.	1 Set
261092-10 †	-	-	-	-	-	26602-10	26605-10 23505-10	Dyno-Pak 10 Sets	

**Chrysler 426 Hemi · Racing Derivatives · Short Block Gaskets & Seals**

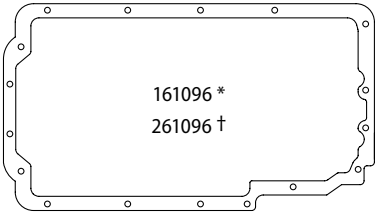
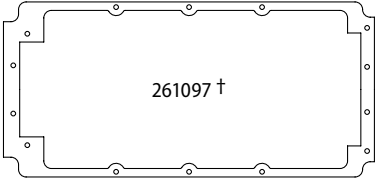
Application	Oil Pan Gasket Set	Timing Cover Gasket Set	Front Cover Gasket Set TC · WP · FP	Water Pump Gasket Set	Fuel Pump Gasket	Water Outlet Gasket	Timing Cover Oil Seal	Rear Main Oil Seal	Qty.
<b>CN Billet Blocks Wide Rail Hemi</b>	 <p>161096 * 261096 †</p> <p><b>Accu-Seal E</b> standard gasket materials, nitrile or silicone seals. * 1-pc gasket, rubberized fiber material.</p>								
	161096 *	-	-	-	-	-	-	-	1 Set
	61096-10 *	-	-	-	-	-	-	-	Dyno-Pak 10 Sets
	<p><b>Accu-Seal Pro</b> premium gasket materials, FKM seals, molded water outlet. † 1-pc gasket · Severe Duty™, .093" thick PTFE-coated, steel-core material.</p>								
	261096 †	-	-	-	-	-	26602	26605 2.75" dia. 23505 3.00" dia.	1 Set
261096-10 †	-	-	-	-	-	26602-10	26605-10 23505-10	Dyno-Pak 10 Sets	
<b>CN Billet Blocks 1040Y/ 1041Y Racing Hemi</b>	 <p>261097 †</p> <p><b>Accu-Seal Pro</b> premium gasket materials, FKM seals, molded water outlet. † 1-pc gasket · Severe Duty™, .093" thick PTFE-coated, steel-core material.</p>								
	261097 †	-	-	-	-	-	26602	26605 2.75" dia. 23505 3.00" dia.	1 Set
	261097-10 †	-	-	-	-	-	26602-10	26605-10 23505-10	Dyno-Pak 10 Sets

**383-440 Wedge · 426 Hemi · SBBK – Short Block Base Kit**

**NEW!**  
— SEE P.8 —

Application	SBBK Gasket / Oil Seal Kit	Contents of Kit
<b>1959-78 383-440 ci RB Wedge 6.3-7.2 L</b>	36403	<b>Includes:</b> Timing Cover · Water Pump · Fuel Pump · Water Outlet Gasket · Timing Cover Seal · 2-pc Rear Main Seal
<b>426 ci Hemi 7.0 L</b>	46403	<b>Includes:</b> Timing Cover · Water Pump · Fuel Pump · Water Outlet Gasket · Timing Cover Seal · 2-pc FKM Rear Main Seal

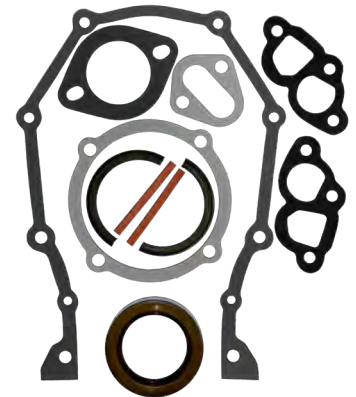

**Chrysler 383-440 Wedge · Valve Cover Gaskets**

Application	Hi-Density Cork 5/16" Thick	<b>Tuff-Bak</b> Laminated Cork		Fuel-Resistant Fiber 1/16" Thick	Steel-Core PTFE-Coated .093" Thick (3/32")	Qty.
	Street / Strip	1/8" Thick	1/4" Thick	Racing / Hi-Vac		
<b>1959-78 383-440 ci RB Wedge 6.3-7.2 L</b>	<p>6 bolts, 2-over-4, fits all 'RB', Indy Wedge, Brodix B1 BS, Edelbrock, and similar.</p>					
	164076	264075	264076	264074	264078	1 Set
	164076-10	264075-10	264076-10	264074-10	264078-10	Dyno-Pak 10 Sets

**Chrysler 426 Hemi · Valve Cover Gaskets**



Application	<b>Molded</b> Silicone Rubber	Rubberized Fiber 3/16" Thick	<b>Tuff-Bak</b> Laminated Cork 1/8" Thick	Fuel Resistant Fiber 1/16" Thick	Steel-Core PTFE-Coated .093" Thick (3/32")	Qty.
	Street / Strip		Racing / Hi-Vac	Sportsman Racing	Severe Duty™	
<b>1964-65 Chrysler A-990 426 Race Hemi 7.0 L</b>	<p>10 bolts, fits only A990 426 Race Hemi cylinder head.</p>					
	-	166276	266275	-	-	1 Set
	-	66276-10	266275-10	-	-	Dyno-Pak 10 Sets
<b>1965-71 Chrysler 426 GEN 2 Hemi 7.0 L</b>	<p>10 bolts, fits Street Hemi &amp; Race Hemi with 1/4" valve cover bolts</p>					
	-	-	266175	166075	266075	1 Set
	-	-	266175-10	66075-10	266075-10	Dyno-Pak 10 Sets



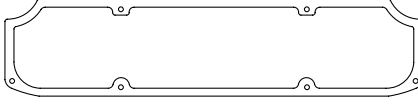
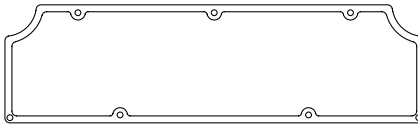
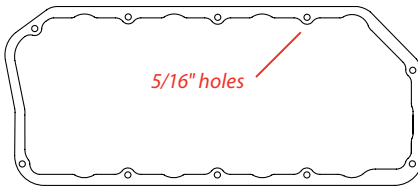
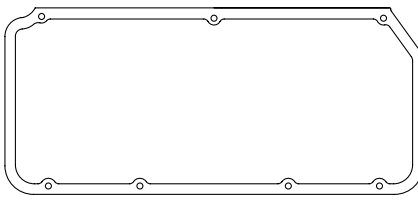
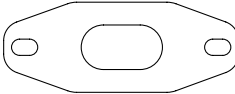

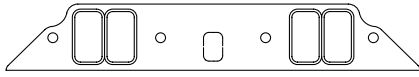
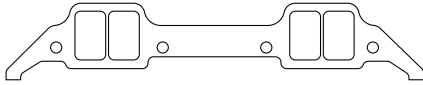
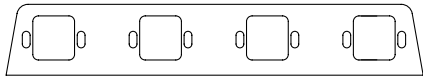
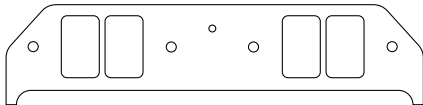
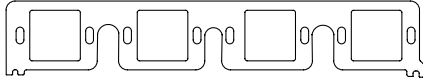
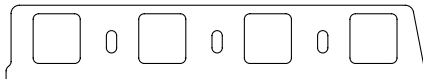

**440 Wedge · 426 Hemi · Racing Derivatives · Valve Cover Gaskets**

Application	Hi-Density Cork .312" Thick	Tuff-Bak Laminated Cork		Fuel-Resistant Fiber 5/8" Thick	Steel-Core PTFE-Coated .093" Thick (3/32")	Qty.
		1/8" Thick	1/4" Thick			
	Street / Strip	Racing / Hi-Vac		Sportsman Racing	Severe Duty™	
<b>Mopar B1</b>	 <p>6 bolts, fits original B1, Brodix B1 Mopar, rounded lower corners, inward curve upper corners.</p>					
	164076	264077	264079	264071	264078	1 Set
	164076-10	264077-10	264079-10	264071-10	264078-10	Dyno-Pak 10 Sets
<b>Koffel B-1 T/S</b>	 <p>7 bolts, 3-over-4, fits only Koffel B-1 T/S 4.840" bore center cylinder heads.</p>					
	165076	265075	265076	265077	265078	1 Set
	165076-10	265075-10	265076-10	265077-10	265078-10	Dyno-Pak 10 Sets
<b>500 ci Racing Hemi</b>	 <p>10 bolts, same shape as Street Hemi – with larger 5/16" bolts to meet NHRA rules.</p>					
	-	-	-	261077	261075	1 Set
	-	-	-	261077-10	261075-10	Dyno-Pak 10 Sets
<b>BAE Fathead / AJPE Muscle Head</b>	 <p>7 bolts, 3-over-4 pattern.</p>					
	-	-	-	163075	263075	1 Set
	-	-	-	163075-10	263075-10	Dyno-Pak 10 Sets
<b>Universal Valve Cover Breather Gaskets</b>	 <p>2 bolts, standard shape fits all popular breathers. * Meets NHRA breather gasket rules.</p>					
	-	-	-	16604	26604 *	1 Set
	-	-	-	16604-10	26604-10 *	Dyno-Pak 10 Sets

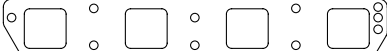
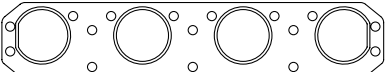

**Chrysler V8 · 383-440 Wedge · 426 Hemi · Intake Gaskets**

Application — Port Size	Thickness	Accu-Seal E Standard Material		Accu-Seal Pro · Premium Materials	
		Packaged 1 Set	Dyno-Pak · 10 Sets	Packaged 1 Set	Dyno-Pak · 10 Sets
<b>1959-78</b> <b>383-440 ci RB Wedge</b> <b>6.3-7.2 L</b> — <b>1.25" x 2.29"</b> <b>Rectangle</b>	 <p>Also fits Brodix B1 BS, Indy Wedge, Edelbrock Performer &amp; similar. Manifold gaskets only</p> <p>† Silicone Bead Sealed Ports</p>				
	.062"	164101	64101-10	264101 †	264101-10 †
<b>440 Max Wedge</b> <b>383-440 ci</b> <b>6.3-7.2 L</b> — <b>1.37" x 2.67"</b> <b>Rectangle</b>	 <p>Also fits Indy 440, Edelbrock Max Wedge. Manifold gaskets only</p>				
	.062"	164102	64102-10	264102	264102-10
<b>1965-71</b> <b>426 GEN 2 Hemi</b> <b>7.0 L</b> — <b>1.87" x 2.00" Square</b>	 <p>8-bolt stock pattern fits factory iron and aluminum heads</p>				
	.062"	166101	66101-10	266101	266101-10
<b>Racing Derivatives</b>					
<b>Mopar B1</b> — <b>1.65" x 2.70"</b> <b>Rectangle</b>	 <p>Also fits Brodix B1 Mopar. Manifold gaskets only.</p>				
	.062"	164104	64104-10	264104	264104-10
<b>426 Racing Hemi</b> — <b>2.27" x 2.27"</b> <b>Square</b>	 <p>Fits Walt Austin Racing Warhead and similar Fuel heads with 8-bolt pattern</p>				
	.062"	166102	66102-10	266102	266102-10
<b>426 Racing Hemi</b> — <b>2.13" x 2.27"</b> <b>Square</b>	 <p>Fits AJPE, BAE, Dart, Stage 5, Indy Legend, KB 10-Bolt, Fathead 3,5,6,8</p>				
	.062"	166103	66103-10	266103	266103-10
<b>Racing Hemi Blower</b> <b>Manifold Ends Seals</b>	 <p>Compressible foam, fits into Racing Hemi blower manifold end rails.</p>				
	.500" Uncompressed	26601	26601-10	—	

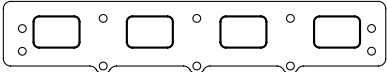
**Chrysler V8 · 383-440 Wedge · 426 Hemi · Exhaust Gaskets**

Application — Port Size	Accu-Seal E		Accu-Seal Pro		Graph-Form	Pro-Copper								
	Standard Material .062"		Premium Material .062"		Hi-Density Graphite .150"	Embossed .043"	Flat-Annealed .062"							
	Packaged 1 Set	Dyno-Pak 10 Sets	Packaged 1 Set	Dyno-Pak 10 Sets	Packaged 1 Set	Packaged 1 Set	Packaged 1 Set							
<b>1963-65</b> <b>413 ci RB Wedge</b> <b>Truck Engine</b> <b>6.7 L</b> — <b>1.70" x 1.30"</b> <b>Rectangle</b>			7 bolts, fits 413 'RB' wedge used in trucks & motorhomes from 1965-71					—	—					
										—	—	—	4264	—
<b>1959-78</b> <b>383-440 ci</b> <b>RB Wedge</b> <b>6.3-7.2 L</b> — <b>1.68" x 1.30"</b> <b>Rectangle</b>			Standard 6-bolt pattern also fits Indy 440, Brodix B1					164081	164081-10	264081	264081-10	464081	4164 *	-
<b>Max Wedge</b> — <b>1.70" x 1.50"</b> <b>Rectangle</b>			Large port standard 6-bolt pattern also fits Indy 572, 600 & Mopar B1					164080	164080-10	264080	264080-10	-	4064 *	E64186
<b>1965-71</b> <b>426-572 Street</b> <b>Hemi</b> <b>7.0-9.3 L</b> — <b>1.74" x 1.74"</b> <b>Square</b>			Stock-configuration iron & aluminum heads					166080	166080-10	266080	266080-10	466080	4266	E66286
<b>426 Hemi · Racing Derivatives</b>														
<b>Early Fuel /</b> <b>Alcohol Heads</b> — <b>2.36" Round</b>			16 bolts, fits Smiley's Headers with 2.5" round openings					—	—	—	—	4466	-	
														—
<b>AJPE / BAE /</b> <b>Dart Fuel Heads</b> — <b>2.52" x 2.05"</b> <b>Rectangle</b>			Extra large port opening to fit Smiley's TF headers, upper bolt holes slotted for universal fit					—	—	—	—	4066	-	
														—
<b>AJPE Stage 1-4</b> <b>Fuel Heads</b> — <b>2.30" x 1.55"</b> <b>Rectangle</b>			Fits AJPE Stage 1 through 4 Top Fuel heads					—	—	—	—	4566	-	
														—

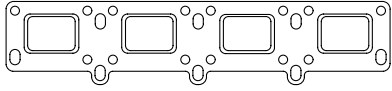
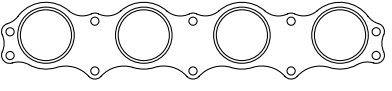
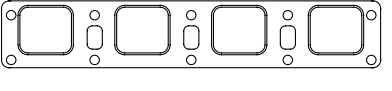
**426 Hemi · Racing Derivatives · Exhaust Gaskets**

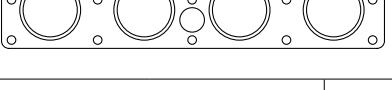
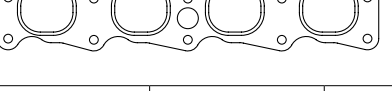
Application — Port Size	Accu-Seal E		Accu-Seal Pro		Graph-Form	Pro-Copper	
	Standard Material .062"		Premium Material .062"		Hi-Density Graphite .150"	Embossed .043"	Flat-Annealed .062"
	Packaged 1 Set	Dyno-Pak 10 Sets	Packaged 1 Set	Dyno-Pak 10 Sets	Packaged 1 Set	Packaged 1 Set	Packaged 1 Set
AJPE Stage 5-7 — 2.33" x 1.67" Rectangle							
	—	—	—	—	—	4766	—
AJPE / Dart Alcohol Heads — 2.50" Round	 Standard 10-bolt pattern for 2.5" round header opening.						
	—	—	—	—	—	4366	—
BAE Fathead 3-4 — 2.56" x 2.29" Rectangle	 Fits most Smiley's headers for BAE Fathead.						
	—	—	—	—	—	4163	—
BAE Fathead 5 — 2.60" x 1.85" Rectangle							
	—	—	—	—	—	4063	—
BAE Fathead 6-8x — 2.45" x 2.05" D Port							
	—	—	—	—	—	4263	—
Veney Alcohol Heads — 2.75" Round	 Standard Veney bolt pattern fits 2.75" round header opening.						
	—	—	—	—	—	4068	—
Veney Alcohol Heads 7.0 L — 2.65" x 2.30" Oval	 Standard Veney bolt pattern fits oval port with oval header opening.						
	168080	168080-10	268080	268080-10	—	4168	—

**Chrysler 383-440 Wedge**  
**Accu-Seal Pro · Performance Head Gaskets**

Application	Image	Bore Opening	Compr. Thick.	Part Number	Description	Qty.
1959-80 383-440 ci 6.4-7.2 L		4.200"	.020"	5642020	Embossed steel shim construction	1
		4.410"		5644120		1
		4.475"		5644720		1

**Chrysler 383-440 Wedge · 426 Hemi**  
**MLS Spartan · Performance Head Gaskets**

Application	Image	Bore Opening	Compr. Thick.	Part Number	Description	Qty.
1959-80 383-440 ci 6.4-7.2 L		4.380"	.039"	M643839	MLS embossed stainless steel construction.	1
			.059"	M643859		1
		4.410"	.039"	M644139		1
		4.500"	.039"	M645039		1
440-500 ci Large Bore 7.2 L		4.280"	.039"	M662839		1
4.375"		M663739		1		
<b>Marine Use:</b> stainless steel construction, all MLS Spartan head gaskets are suitable for use in marine applications.						

**Chrysler Wedge · 1959-80 · 383-440 ci · 6.4-7.2 L**

**Pro-Copper  
Racing Head Gaskets**

For use with o-rings & sealant

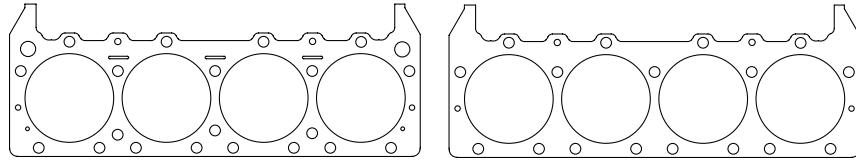

No water holes: use suffix "NW"

Bore Opening	Thickness								Qty.
	.021"	.032"	.043"	.050"	.062"	.072"	.080"	.093"	
4.380" round	P643821	P643832	P643843	P643850	P643862	P643872	P643880	P643893	1
4.440" round	P644421	P644432	P644443	P644450	P644462	P644472	P644480	P644493	1
4.520" round	P645221	P645232	P645243	P645250	P645262	P645272	P645280	P645293	1
4.570" round	P645721	P645732	P645743	P645750	P645762	P645772	P645780	P645793	1

**Titan  
Copper Racing Head Gaskets**

Sealed coolant passages, for use with o-rings & sealant

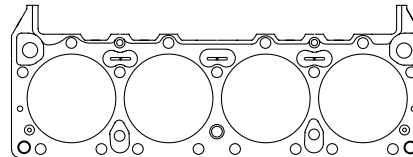

Bore Opening	Thickness								Qty.
	.021"	.032"	.043"	.050"	.062"	.072"	.080"	.093"	
4.380" round	–	T643832	T643843	T643850	T643862	T643872	T643880	T643893	1
4.440" round	–	T644432	T644443	T644450	T644462	T644472	T644480	T644493	1
4.520" round	–	T645232	T645243	T645250	T645262	T645272	T645280	T645293	1
4.570" round	–	T645732	T645743	T645750	T645762	T645772	T645780	T645793	1

**ICS  
Copper Racing Head Gaskets**

Sealed coolant passages, integral combustion o-ring

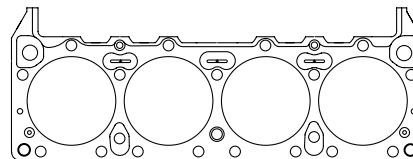

Bore Opening	Thickness								Qty.
	.021"	.032"	.043"	.050"	.062"	.072"	.080"	.093"	
4.380" round	–	–	S643843	S643850	S643862	S643872	S643880	S643893	1
4.440" round	–	–	S644443	S644450	S644462	S644472	S644480	S644493	1
4.520" round	–	–	S645243	S645250	S645262	S645272	S645280	S645293	1
4.570" round	–	–	S645743	S645750	S645762	S645772	S645780	S645793	1

**Chrysler Street Hemi • 1965-Up • 426-572 ci • 7.0-9.3 L**

**Pro-Copper  
Racing Head Gaskets**

For use with o-rings & sealant

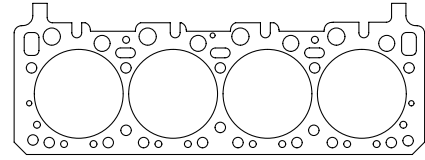

Bore Opening	Thickness								Qty.
	.021"	.032"	.043"	.050"	.062"	.072"	.080"	.093"	
4.250"	P662521	P662532	P662543	P662550	P662562	P662572	P662580	P662593	1
4.320"	P663221	P663232	P663243	P663250	P663262	P663272	P663280	P663293	1
4.380"	P663821	P663832	P663843	P663850	P663862	P663872	P663880	P663893	1
4.440"	P664421	P664432	P664443	P664450	P664462	P664472	P664480	P664493	1
4.520" round	P665221	P665232	P665243	P665250	P665262	P665272	P665280	P665293	1

**Titan  
Copper Racing Head Gaskets**

Sealed coolant passages, for use with o-rings & sealant

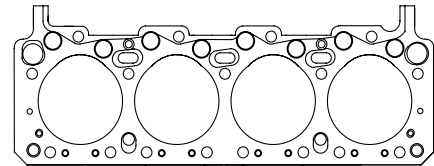

Bore Opening	Thickness								Qty.
	.021"	.032"	.043"	.050"	.062"	.072"	.080"	.093"	
4.250"	–	T662532	T662543	T662550	T662562	T662572	T662580	T662593	1
4.320"	–	T663232	T663243	T663250	T663262	T663272	T663280	T663293	1
4.380"	–	T663832	T663843	T663850	T663862	T663872	T663880	T663893	1
4.440"	–	T664432	T664443	T664450	T664462	T664472	T664480	T664493	1
4.520" round	–	T665232	T665243	T665250	T665262	T665272	T665280	T665293	1

**ICS  
Copper Racing Head Gaskets**

Sealed coolant passages, integral combustion o-ring

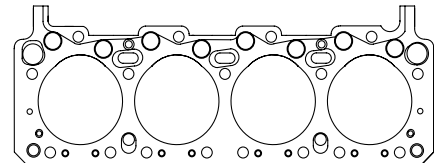

Bore Opening	Thickness								Qty.
	.021"	.032"	.043"	.050"	.062"	.072"	.080"	.093"	
4.250-4.440"	–	–	No Fit: intake valve notch extends beyond 4.440" diameter						
4.520" round	–	–	S665243	S665250	S665262	S665272	S665280	S665293	1

**Note:** Pro-Copper, Titan, & ICS — for Keith Black Aluminum Street Hemi, use suffix "KB".

**426 Hemi - Racing Derivatives • AJPE, BAE, Dart, KB, TFX**

**Pro-Copper  
Racing Head Gaskets**

For use with o-rings & sealant

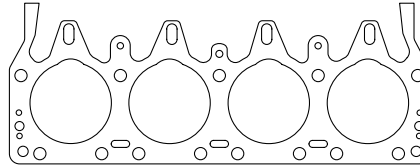

Bore Opening	Thickness								Qty.
	.043"	.050"	.062"	.072"	.080"	.093"	.100"	.110"	
4.200"	P612043	P612050	P612062	P612072	P612080	P612093	–	–	1
4.250"	P612543	P612550	P612562	P612572	P612580	P612593	–	–	1

**426 Hemi - Racing Derivatives • AJPE Muscle Head, BAE Fathead**

**Pro-Copper  
Racing Head Gaskets**

For use with o-rings & sealant

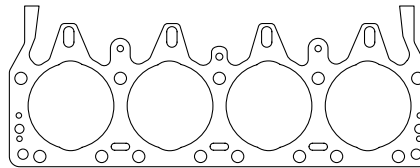

Bore Opening	Thickness								Qty.
	.043"	.050"	.062"	.072"	.080"	.093"	.100"	.110"	
4.380"	P633843	P633850	P633862	P633872	P633880	P633893	–	–	1
4.440"	P634443	P634450	P634462	P634472	P634480	P634493	–	–	1
4.470"	P634743	P634750	P634762	P634772	P634780	P634793	–	–	1

**426 Hemi - Racing Derivatives • Ken Veney Alcohol**

**Pro-Copper  
Racing Head Gaskets**

For use with o-rings & sealant

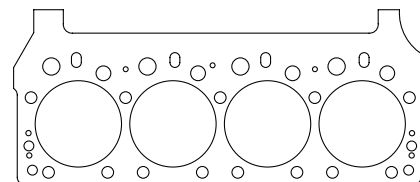

Bore Opening	Thickness								Qty.
	.043"	.050"	.062"	.072"	.080"	.093"	.100"	.110"	
4.380"	P683843	P683850	P683862	P683872	P683880	P683893	–	–	1
4.440"	P684443	P684450	P684462	P684472	P684480	P684493	–	–	1
4.470"	P684743	P684750	P684762	P684772	P684780	P684793	–	–	1



**Chrysler 4.7L & Gen III Hemi V8 · Exhaust Gaskets**

Application — Port Size	Accu-Seal E		Accu-Seal Pro		Graph-Form	Pro-Copper	
	Standard Material .062"		Premium Material .062"		Hi-Density Graphite .150"	Embossed .043"	Flat-Annealed .062"
	Packaged 1 Set	Dyno-Pak 10 Sets	Packaged 1 Set	Dyno-Pak 10 Sets	Packaged 1 Set	Packaged 1 Set	Packaged 1 Set
1999-Up V8 287 ci · 4.7 L — 1.45" x 1.20" D-port						Fits stock D-port manifolds.	
	157081	157081-10	257081	257081-10	457081	4157	—
1999-Up V8 287 ci · 4.7 L — 1.63" Round						Fits 1.5" ID headers.	
	157182	157182-10	257182	257182-10	457182	—	—
2003-Up V8 347 ci · 5.7 L — 1.40" x 1.30" Rectangle							
	158081	158081-10	258081	258081-10	458081	—	—

**Chrysler Gen III Hemi · MLS Spartan · Performance Head Gaskets**

Application	Image	Bore Opening	Comp. Thickness	Part Number	Description	Qty.
2003-Up V8 347 ci 5.7 L	<p>* Note: representative right side image. 5.7 L head gaskets cannot be reversed.</p>	4.050"	.039"	M580539L <i>Left*</i>	MLS embossed stainless steel construction.	1
				M580539R <i>Right*</i>		1
2005-2010 V8 372 ci 6.1 L		4.100"	.039"	M591039		1
		4.185"	.039"	M591839		1
<p><b>Marine Use:</b> stainless steel construction, all MLS Spartan head gaskets are suitable for use in marine applications.</p>						

**Chrysler Gen III Hemi • 372-392 ci • 6.1-6.4 L**

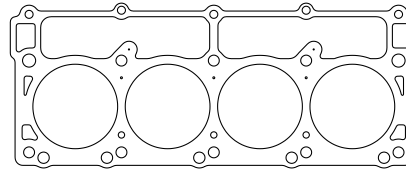

**Pro-Copper  
Racing Head Gaskets**

For use with o-rings & sealant

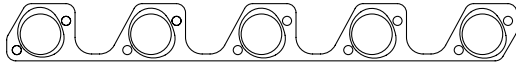

Bore Opening	Thickness								Qty.
	.021"	.032"	.043"	.050"	.062"	.072"	.080"	.093"	
4.100" round	P591021L P591021R	P591032L P591032R	P591043L P591043R	P591050L P591050R	P591062L P591062R	P591072L P591072R	P591080L P591080R	P591093L P591093R	1

**Other Chrysler Engines • Exhaust Gaskets**

Application — Port Size	Accu-Seal E		Accu-Seal Pro		Graph-Form	Pro-Copper	
	Standard Material .062"		Premium Material .062"		Hi-Density Graphite .150"	Embossed .043"	Flat-Annealed .062"
	Packaged 1 Set	Dyno-Pak 10 Sets	Packaged 1 Set	Dyno-Pak 10 Sets	Packaged 1 Set	Packaged 1 Set	Packaged 1 Set
<b>2000-05 L4 • A588 Dodge Neon / PT Cruiser 122 ci • 2.0 L</b> — 1.62" Round	 <p style="text-align: right;">Set contains 1 pc.</p>						
	—		—		—	9460 1 pc.	—
<b>1994-04 Dodge V10 Pickup Iron Heads 488 ci • 8.0 L</b> — 1.75" x 1.80" Round							
	—		—		—	4059	—
<b>2004-06 Dodge SRT10 Aluminum Heads 505 ci • 8.3 L</b> — 1.59" x 1.68" D Port							
	—		—		—	4159	—
<b>2007-17 V10 Dodge SRT10 Aluminum Heads 505 ci • 8.3 L</b> — 1.70" x 1.52" D Port							
	—		—		—	4259	—

**Dodge SRT-4 Turbo · 2.4 L · 148 ci**

**Pro-Copper  
Racing Head Gaskets**

For use with o-rings & sealant

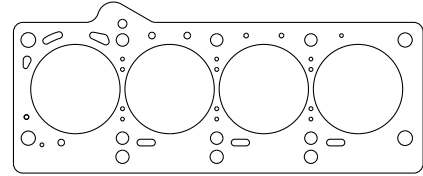

Bore Opening	Thickness								Qty.
	.021"	.032"	.043"	.050"	.062"	.072"	.080"	.093"	
3.500" round	P926821	P926832	P926843	P926850	P926862	P926872	P926880	P926893	1

**Titan  
Copper Racing Head Gaskets**

Sealed coolant passages, for use with o-rings & sealant

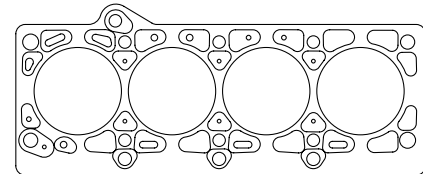

Bore Opening	Thickness								Qty.
	.021"	.032"	.043"	.050"	.062"	.072"	.080"	.093"	
3.500" round	–	T926832	T926843	T926850	T926862	T926872	T926880	T926893	1

**ICS  
Copper Racing Head Gaskets**

Sealed coolant passages, integral combustion o-ring

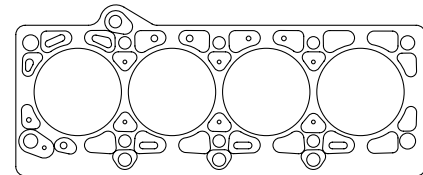

Bore Opening	Thickness								Qty.
	.021"	.032"	.043"	.050"	.062"	.072"	.080"	.093"	
3.500" round	–	–	S926843	S926850	S926862	S926872	S926880	S926893	1

**Prowler V6 · SOHC · 3.5L · 214 ci · Engine Code EGG**

**Pro-Copper  
Racing Head Gaskets**

For use with o-rings & sealant

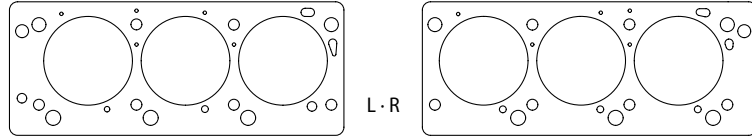

Bore Opening	Thickness								Qty.
	.021"	.032"	.043"	.050"	.062"	.072"	.080"	.093"	
3.850" round	P926921L	P926932L	P926943L	P926950L	P926962L	P926972L	P926980L	P926993L	1
3.850" round	P926921R	P926932R	P926943R	P926950R	P926962R	P926972R	P926980R	P926993R	1

**Titan  
Copper Racing  
Head Gaskets**

Sealed coolant passages,  
for use with o-rings & sealant

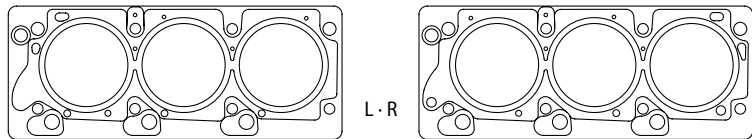

Bore Opening	Thickness								Qty.
	.021"	.032"	.043"	.050"	.062"	.072"	.080"	.093"	
3.850" round	–	T926932L	T926943L	T926950L	T926962L	T926972L	T926980L	T926993L	1
3.850" round	–	T926932R	T926943R	T926950R	T926962R	T926972R	T926980R	T926993R	1

**ICS  
Copper Racing  
Head Gaskets**

Sealed coolant passages,  
integral combustion o-ring

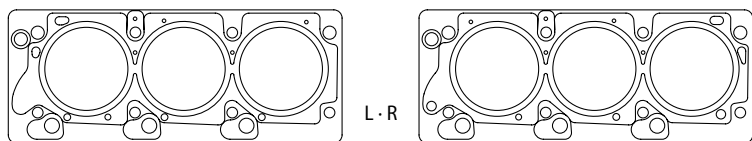

Bore Opening	Thickness								Qty.
	.021"	.032"	.043"	.050"	.062"	.072"	.080"	.093"	
3.850" round	–	–	S926943L	S926950L	S926962L	S926972L	S926980L	S926993L	1
3.850" round	–	–	S926943R	S926950R	S926962R	S926972R	S926980R	S926993R	1

**Dodge Viper • Gen 1 • V10 • 8.0 L • 488 ci**

**Pro-Copper  
Racing Head Gaskets**

For use with o-rings & sealant

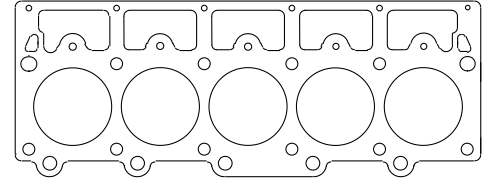

Bore Opening	Thickness								Qty.
	.021"	.032"	.043"	.050"	.062"	.072"	.080"	.093"	
4.060" round	P909321	P909332	P909343	P909350	P909362	P909372	P909380	P909393	1

**Dodge Viper • Gen 2-5 • V10 • 8.0-8.4 L • 488-513 ci**

**Pro-Copper  
Racing Head Gaskets**

For use with o-rings & sealant

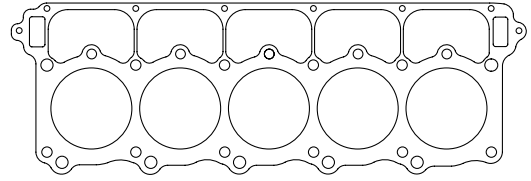

Bore Opening	Thickness								Qty.
	.021"	.032"	.043"	.050"	.062"	.072"	.080"	.093"	
4.060" round	P924321	P924332	P924343	P924350	P924362	P924372	P924380	P924393	1
4.090" round	P924221	P924232	P924243	P924250	P924262	P924272	P924280	P924293	1

**Titan  
Copper Racing Head Gaskets**

Sealed coolant passages, for use with o-rings & sealant

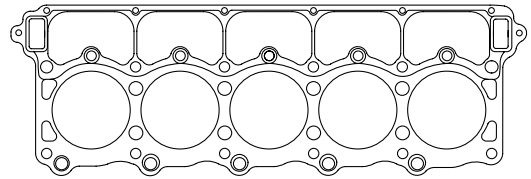

Bore Opening	Thickness								Qty.
	.021"	.032"	.043"	.050"	.062"	.072"	.080"	.093"	
4.060" round	–	T924332	T924343	T924350	T924362	T924372	T924380	T924393	1
4.090" round	–	T924232	T924243	T924250	T924262	T924272	T924280	T924293	1

**ICS  
Copper Racing Head Gaskets**

Sealed coolant passages, integral combustion o-ring

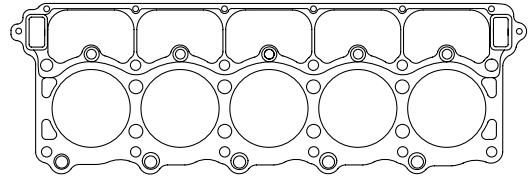

Bore Opening	Thickness								Qty.
	.021"	.032"	.043"	.050"	.062"	.072"	.080"	.093"	
4.060" round	–	–	S924343	S924350	S924362	S924372	S924380	S924393	1
4.090" round	–	–	S924243	S924250	S924262	S924272	S924280	S924293	1

**Ferrari L6 F116/F133**  
**MLS Spartan · Performance Head Gaskets**

Application	Image	Bore Opening	Compr. Thick.	Part Number	Description	Qty.
5.5-5.8 L 336-354 ci 1992-11		90.5 mm 3.563"	1.5 mm .059"	M338404	MLS embossed stainless steel construction.	1
<b>Marine Use:</b> stainless steel construction, all MLS Spartan head gaskets are suitable for use in marine applications.						

**Ferrari 308-328-348 V8**

<b>Pro-Copper Racing Head Gaskets</b> For use with o-rings & sealant									
Bore Opening	Thickness								Qty.
	.021"	.032"	.043"	.050"	.062"	.072"	.080"	.093"	
85.8 mm 3.378" round	P920721	P920732	P920743	P920750	P920762	P920772	P920780	P920793	1

**Ferrari F40 V8**

<b>Titan Copper Racing Head Gaskets</b> Sealed coolant passages, for use with o-rings & sealant									
Bore Opening	Thickness								Qty.
	.021"	.032"	.043"	.050"	.062"	.072"	.080"	.093"	
84 mm 3.310" round	T930121	T930132	T930143	T930150	T930162	T930172	T930180	T930193	1

**Ferrari Testarossa V12**

<b>Pro-Copper Racing Head Gaskets</b> For use with o-rings & sealant									
Bore Opening	Thickness								Qty.
	.021"	.032"	.043"	.050"	.062"	.072"	.080"	.093"	
83.2 mm 3.275" round	P929821	P929832	P929843	P929850	P929862	P929872	P929880	P929893	1

**Ford Inline 4 Cylinder L4 · Short Block Gaskets & Seals**

Application	Oil Pan Gasket Set	Timing Cover Gasket Set	Front Cover Gasket Set TC · WP · FP	Water Pump Gasket Set	Fuel Pump Gasket	Water Outlet Gasket	Timing Cover Oil Seal	Rear Main Oil Seal	Qty.
1974-97 2.3 L · SOHC SVO 140 ci	 <p>* <b>Accu-Seal E</b> standard gasket materials, nitrile or silicone seals.</p> <p><b>Accu-Seal Pro</b> premium gasket materials, FKM seals.</p> <p>† 1-pc molded silicone with crush limiters.</p>								
	223090 †					12308	12302 *	13604 * 2 Pc.	1 Set
	223090-10 †	12303	12300	12301	11106	12308-10	12302-10 *	13604-10 *	Dyno-Pak 10 Sets

**Ford Inline 4 Cylinder L4 · Valve Cover Gaskets**

Application	Molded Silicone Rubber	Hi-Density Cork 3/16" Thick	Hi-Density Cork 5/16" Thick	Tuff-Bak Laminated Cork		Steel Core PTFE-Coated .093" Thick (3/32")	Qty.
				1/8" Thick	1/4" Thick		
				Street / Strip			
1974-97 2.3 L · SOHC SVO 140 ci							
	223075						1 Set
	223075-10	-	-	-	-	-	Dyno-Pak 10 Sets

**Ford Inline 4 Cylinder L4 · Intake Gaskets**

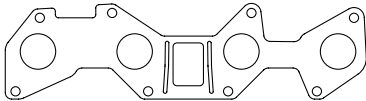
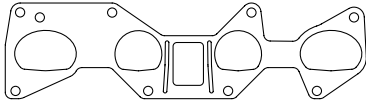
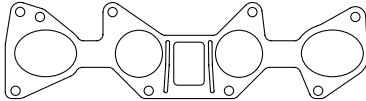
Application — Port Size	Thickness	Accu-Seal E Standard Material		Accu-Seal Pro · Premium Materials	
		Packaged 1 Pc.	Dyno-Pak · 10 Pcs.	Packaged 1 Pc.	Dyno-Pak · 10 Pcs.
1974-97 2.3 L · SOHC SVO 140 ci — 1.48" Round					
	.8 mm · .032"	123101	-	223101	223101-10
1974-97 2.3 L · SOHC SVO 140 ci — D-Port					
	.8 mm · .032"	123105	-	223105	223105-10
1974-97 2.3 L · SOHC SVO 140 ci — Oval Port					
	.8 mm · .032"	123106	-	223106	223106-10

**Ford Inline 4 Cylinder L4 · Exhaust Gaskets**

Application — Port Size	Accu-Seal E		Accu-Seal Pro		Graph-Form	Pro-Copper	
	Standard Material .062"		Premium Material .062"		Hi-Density Graphite .150"	Embossed .043"	Flat-Annealed .062"
	Packaged 1 Pc.	Dyno-Pak 10 Pcs.	Packaged 1 Pc.	Dyno-Pak 10 Pcs.	Packaged 1 Pc.	Packaged 1 Pc.	Packaged 1 Pc.
1995-04 2.0 L · 121 ci DOHC Zetec Head — 1.50" Round							
	123082	23082-10	223082	223082-10	—	9419	—
2012-13 2.0 L · 121 ci DOHC · Zetec R Turbo Head — 1.70" x 1.35" Oval							
	123083	23083-10	223083	223083-10	—	9421	—
1974-83 2.3 L · 140 ci SOHC — 1.50" Round							
	123080	23080-10	223080	223080-10	—	4023	—
1991-93 2.3 L · 140 ci SOHC SVO Turbo Head — 1.50" Oval							
	—	—	—	—	—	—	E23186
1991-03 2.3 L · 140 ci Esslinger ARCA Head — 1.57" x 1.70" Square					Rectangle port fits Esslinger ARCA Aluminum Head. 4 individual port gaskets · Set contains 4 pcs.		
	123081	23081-10	223081	223081-10	—	4123 4 pcs.	—
2000-10 2.3-2.5 L 140-155 ci DOHC Duratec Head — 1.75" Round							
	123084	23084-10	223084	223084-10	—	9440	—



**Ford Inline 4-Cylinder**  
**MLS Spartan · Performance Head Gaskets**

Application	Image	Bore Opening	Compr. Thick.	Part Number	Description	Qty.
2013-UP Fiesta R5 Rally 98 ci 1.6 L		85.5 mm 3.367"	1.3 mm .053"	M338403	MLS embossed stainless steel construction.	1
LNA / LNB / LHB 98 ci 1.6 L		81.0 mm 3.189"	1.3 mm .053"	M338270GS	MLS Spartan with <b>Gas-Stopper</b> embossed stainless steel construction.	1
			1.6 mm .063"	M338271GS		1
			1.9 mm .075"	M338272GS		1
2010-UP Ecoboost JQDA/ JQDB/JTBA/ JTDA 98 ci 1.6 L		80.0 mm 3.150"	1.0 mm .039"	M338447GS	MLS Spartan with <b>Gas-Stopper</b> embossed stainless steel construction.	1
1987-90 Cosworth YB/N5B-F 121 ci 2.0 L		93.5 mm 3.682"	1.0 mm .039"	M338047GS		1
			1.1 mm .045"	M338044GS		1
			1.3 mm .051"	M338041GS		1
			1.1 mm .045"	M338043GS		1
			1.3 mm .051"	M338040GS		1
1990-93 Cosworth YB/N5B-F 121 ci 2.0 L		94.5 mm 3.721"	1.0 mm .039"	M338048GS		1
			1.1 mm .045"	M338045GS		1
			1.3 mm .051"	M338042GS		1
1992-95 Cosworth YB/N5B-F 121 ci 2.0 L		92.5 mm 3.642"	1.0 mm .039"	M338048GS		1
			1.1 mm .045"	M338045GS		1
			1.3 mm .051"	M338042GS		1
EDBA-D/ EDDDB-F/ NGA-D 121 ci 2.0 L		86.2 mm 3.394"	1.0 mm .039"	M338267GS	1	
			1.3 mm .051"	M338268GS	1	
			1.6 mm .063"	M338269GS	1	

**Marine Use:** stainless steel construction, all MLS Spartan head gaskets are suitable for use in marine applications.

**Ford Inline 4-Cylinder**  
**MLS Spartan · Performance Head Gaskets**

Application	Image	Bore Opening	Compr. Thick.	Part Number	Description	Qty.
2010-Up EcoBoost TNCD / TNCF / R9CB / R9CF / R9CH 121 ci · 2.0 L		89.0 mm 3.504"	1.2 mm .049"	M338483GS	MLS Spartan with <b>Gas-Stopper</b> embossed stainless steel construction.	1
2000-Up Duratec TBBA / SYDA / GZFB / XQDA 121-140 ci 2.0-2.3 L		89.0 mm 3.504"	0.8 mm .030"	M338469GS		1
			1.0 mm .039"	M338471GS	1	
		91.0 mm 3.583"	0.7 mm .028"	M338470	1	
			1.0 mm .039"	M338472	1	
2015-Up Mustang / Focus RS / EcoBoost YVDA/N38H/ N48H 140 ci · 2.3 L		89.0 mm 3.504"	1.3 mm .051"	M338482GS	MLS Spartan with <b>Gas-Stopper</b> embossed stainless steel construction.	1
		90.1 mm 3.547"	1.3 mm .051"	M338515GS		1
1974-86 L4 SOHC 140 ci 2.3 L		97.3 mm 3.831"	1.0 mm .039"	M338301	MLS Spartan embossed stainless steel construction.	1
2008-Up Duratec GBVAF / GBVAL / GBZAK / S7GA 155 ci 2.5 L		91.0 mm 3.583"	0.7 mm .028"	M338473		1
		91.0 mm 3.583"	1.0 mm .039"	M338474	1	
2005-Up Focus ST / RS HUBA / HUWA / HYDB / JZDA 155 ci 2.5 L		83.0 mm 3.268"	1.2 mm .047"	M338284GS	MLS Spartan with <b>Gas-Stopper</b> embossed stainless steel construction.	1
		83.0 mm 3.268"	1.6 mm .063"	M338429GS		1
<b>Marine Use:</b> stainless steel construction, all MLS Spartan head gaskets are suitable for use in marine applications.						

**Ford 4-5-6 Cylinder**  
**Vulcan Cut-Ring · Performance Head Gaskets**

Application	Image	Bore Opening	Compr. Thick.	Part Number	Description	Qty.
1995-98 Cosworth YB / N5B-F 121 ci 2.0 L		91.4 mm 3.599"	1.3 mm .051"	CR330029	Stainless steel Cut-Ring combustion seals (not pictured).  Composite gasket body construction.	1
1992-95 Escort/ Cosworth 121 ci 2.0 L		92.1 mm 3.626"	1.3 mm .051"	CR330030		1
1992-95 Cosworth YB/N5B-F 121 ci 2.0 L		92.1 mm 3.626"	2.0 mm .079"	CR330046		1
1992-95 Cosworth YB/N5B-F 121 ci 2.0 L		92.5 mm 3.642"	1.3 mm .051"	CR330063		1
2013-18 Focus ST / RS EcoBoost 2.0-2.5 L		3.50" 89.0 mm	.039" 1.0 mm	CR330151		1
			.051" 1.3 mm	CR330152		1
2000-14 Duratec 121-140 ci 2.0-2.3 L		84.0 mm 3.308"	1.3 mm .051"	CR330065		1
			88.5 mm 3.485"	1.3 mm .051"		CR330064
2015-20 Mustang / Focus RS EcoBoost 140ci · 2.3L		3.54" 90.0 mm	.051" 1.3 mm	CR330149		1
1974-86 L4 SOHC 140 ci 2.3 L		99.6 mm 3.922"	1.0 mm 0.039"	CR330132		1

**Ford 4-5-6 Cylinder · Vulcan Cut-Ring · Performance Head Gaskets**

Application	Image	Bore Opening	Compr. Thick.	Part Number	Description	Qty.
2005-Up Duratec HUBA / HUWA / HYDB / JZDA 155 ci · 2.5 L		84.0 mm 3.308"	1.6 mm .063"	CR330045	Stainless steel Cut-Ring combustion seals (not pictured).  Composite gasket body construction.	1
2002-07 Meba-Reba AJ 183 ci 3.0L		97.6 mm 3.843"	1.0 mm .039"	CR330032 <i>Left</i>		1
				CR330031 <i>Right</i>		1
2002-16 Barra DOHC · L6 4.0 L · 244 ci		93.8mm 3.69"	1.0 mm .039"	CR330128		

**Ford Zetec/Zetec R DOHC · 1992-2004 · 2.0 L · 122 ci**

<p><b>Titan</b> <b>Copper Racing Head Gaskets</b> Sealed coolant passages, for use with o-rings &amp; sealant</p>									
Bore Opening	Thickness								Qty.
	.021"	.032"	.043"	.050"	.062"	.072"	.080"	.093"	
97.8 mm round 3.850"	—	T913232	T913243	T913250	T913262	T913272	T913280	T913293	1
<p><b>ICS</b> <b>Copper Racing Head Gaskets</b> Sealed coolant passages, integral combustion o-ring</p>									
Bore Opening	Thickness								Qty.
	.021"	.032"	.043"	.050"	.062"	.072"	.080"	.093"	
97.8 mm round 3.850"	—	—	S913243	S913250	S913262	S913272	S913280	S913293	1

**Ford Pinto/Ranger SOHC Inline 4 Cylinder • 1974-87 • 2.3 L • 141 ci**

**Pro-Copper  
Racing Head Gaskets**

For use with o-rings & sealant

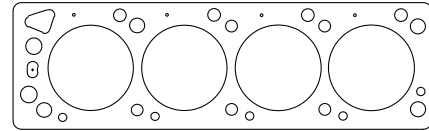

Bore Opening	Thickness								Qty.
	.021"	.032"	.043"	.050"	.062"	.072"	.080"	.093"	
97.8 mm round 3.850"	P912221	P912232	P912243	P912250	P912262	P912272	P912280	P912293	1
100.3 mm round 3.950"	P239521	P239532	P239543	P239550	P239562	P239572	P239580	P239593	1
101.9 mm round 4.010"	P230121	P230132	P230143	P230150	P230162	P230172	P230180	P230193	1

**Titan  
Copper Racing Head Gaskets**

Sealed coolant passages, for use with o-rings & sealant

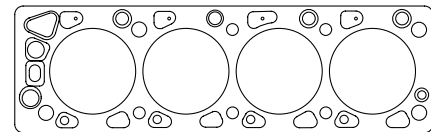

Bore Opening	Thickness								Qty.
	.021"	.032"	.043"	.050"	.062"	.072"	.080"	.093"	
97.8 mm round 3.850"	–	T912232	T912243	T912250	T912262	T912272	T912280	T912293	1
100.3 mm round 3.950"	–	T239532	T239543	T239550	T239562	T239572	T239580	T239593	1
101.9 mm round 4.010"	–	T230132	T230143	T230150	T230162	T230172	T230180	T230193	1

**ICS  
Copper Racing Head Gaskets**

Sealed coolant passages, integral combustion o-ring

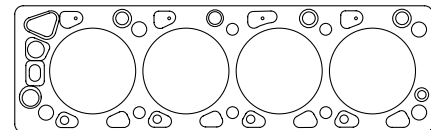

Bore Opening	Thickness								Qty.
	.021"	.032"	.043"	.050"	.062"	.072"	.080"	.093"	
97.8 mm round 3.850"	–	–	S912243	S912250	S912262	S912272	S912280	S912293	1
100.3 mm round 3.9510"	–	–	S239543	S239550	S239562	S239572	S239580	S239593	1
101.9 mm round 4.010"	–	–	No Fit: insufficient area between bores						1

**Ford/Mazda Duratec DOHC • 2001-Up • 2.3 L • 141 ci**

**Pro-Copper  
Racing Head Gaskets**

For use with o-rings & sealant

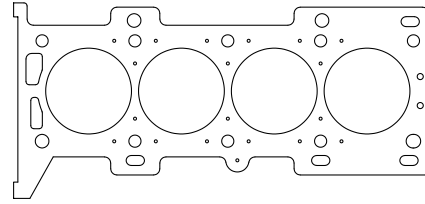

Bore Opening	Thickness								Qty.
	.021"	.032"	.043"	.050"	.062"	.072"	.080"	.093"	
88.9 mm round 3.500"	P925621	P925632	P925643	P925650	P925662	P925672	P925680	P925693	1

**Titan  
Copper Racing Head Gaskets**

Sealed coolant passages, for use with o-rings & sealant

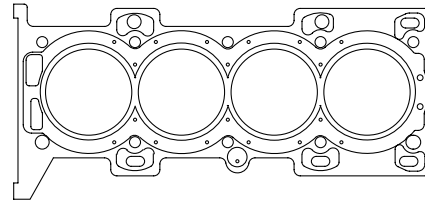

Bore Opening	Thickness								Qty.
	.021"	.032"	.043"	.050"	.062"	.072"	.080"	.093"	
88.9 mm round 3.500"	-	T925632	T925643	T925650	T925662	T925672	T925680	T925693	1

**ICS  
Copper Racing Head Gaskets**

Sealed coolant passages, integral combustion o-ring

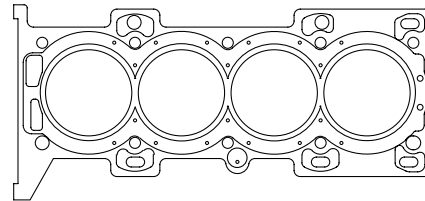

Bore Opening	Thickness								Qty.
	.021"	.032"	.043"	.050"	.062"	.072"	.080"	.093"	
88.9 mm round 3.500"	-	-	S925643	S925650	S925662	S925672	S925680	S925693	1

**Ford Flathead 39-48 V8**

**Pro-Copper  
Racing Head Gaskets**

For use with o-rings & sealant

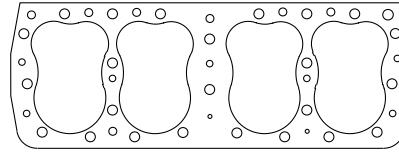

Bore Opening	Thickness								Qty.
	.021"	.032"	.043"	.050"	.062"	.072"	.080"	.093"	
3.375" Irregular	P908021	P908032	P908043	P908050	P908062	P908072	P908080	P908093	1

**Ford-Tony Barron Flathead**

**Pro-Copper  
Racing Head Gaskets**

For use with o-rings & sealant

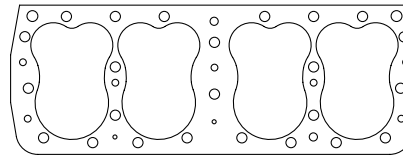

Bore Opening	Thickness								Qty.
	.021"	.032"	.043"	.050"	.062"	.072"	.080"	.093"	
3.395" irregular	P908121	P908132	P908143	P908150	P908162	P908172	P908180	P908193	1

**Ford-Ardun OHV**

**Pro-Copper  
Racing Head Gaskets**

For use with o-rings & sealant

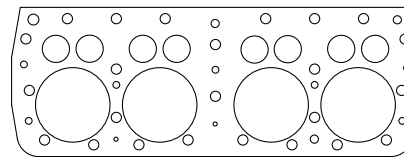

Bore Opening	Thickness								Qty.
	.021"	.032"	.043"	.050"	.062"	.072"	.080"	.093"	
3.425" round	P908221	P908232	P908243	P908250	P908262	P908272	P908280	P908293	1

**Ford Flathead 49-53**

**Pro-Copper  
Racing Head Gaskets**

For use with o-rings & sealant

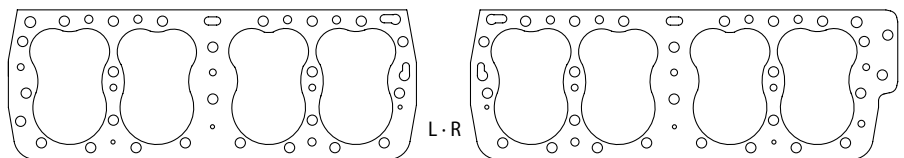

Bore Opening	Thickness								Qty.
	.021"	.032"	.043"	.050"	.062"	.072"	.080"	.093"	
3.378" Irregular	P908321L P908321R	P908332L P908332R	P908343L P908343R	P908350L P908350R	P908362L P908362R	P908372L P908372R	P908380L P908380R	P908393L P908393R	1

**Ford Model A & B**

**Pro-Copper  
Racing Head Gaskets**

For use with o-rings & sealant

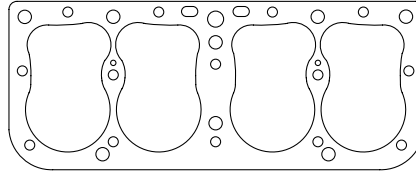

Bore Opening	Thickness								Qty.
	.021"	.032"	.043"	.050"	.062"	.072"	.080"	.093"	
3.955" irregular	P908421	P908432	P908443	P908450	P908462	P908472	P908480	P908493	1
4.012" irregular	P908521	P908532	P908543	P908550	P908562	P908572	P908580	P908593	1

**Ford Model A & B w/ Overhead Valves**

**Pro-Copper  
Racing Head Gaskets**

For use with o-rings & sealant

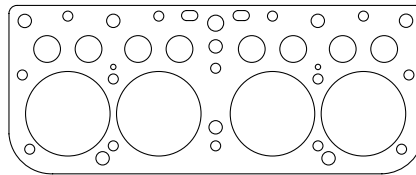

Bore Opening	Thickness								Qty.
	.021"	.032"	.043"	.050"	.062"	.072"	.080"	.093"	
3.950" irregular	P908621	P908632	P908643	P908650	P908662	P908672	P908680	P908693	1

**Ford-Donovan Model D**

**Pro-Copper  
Racing Head Gaskets**



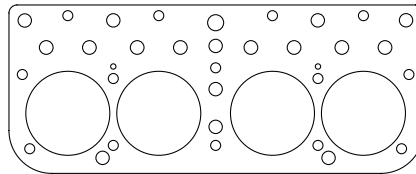

For use with o-rings & sealant





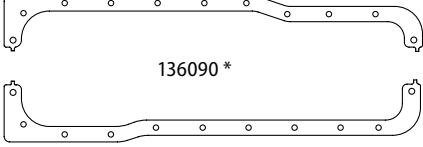

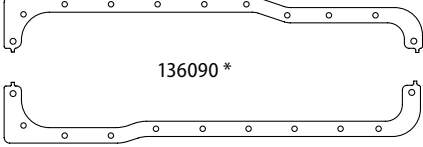
Bore Opening	Thickness								Qty.
	.021"	.032"	.043"	.050"	.062"	.072"	.080"	.093"	
3.925" round	P908721	P908732	P908743	P908750	P908762	P908772	P908780	P908793	1

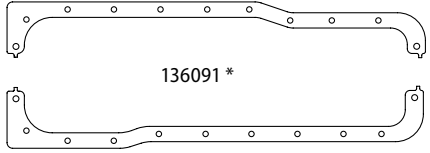

**Ford 289-351W Small Block V8 · Short Block Gaskets & Seals**

Application	Oil Pan Gasket Set	Timing Cover Gasket Set	Front Cover Gasket Set TC · WP · FP	Water Pump Gasket Set	Fuel Pump Gasket	Water Outlet Gasket	Timing Cover Oil Seal	Rear Main Oil Seal	Qty.
<b>1963-82 289-302 ci 4.7-5.0 L</b>  <b>Including Boss 302</b>	 <p><b>Accu-Seal E</b> standard gasket materials, nitrile or silicone seals.</p> <p>* OEM-style 4-pc set w/ rubberized fiber rails (end seals not pictured).</p>								
	136090 *	13603	13600	13601	11106 <i>supersedes</i> 13606	13608	13602	13604 2 Pc.	1 Set
	36090-10 *	—	3600-10	3601-10	1106-10 <i>supersedes</i> 3606-10	3608-10	3602-10	3604-10	Dyno-Pak 10 Sets
	 <p><b>Accu-Seal Pro</b> premium gasket materials, FKM seals.</p> <p>† 1-pc molded silicone. Steel backbone &amp; crush limiters.</p>								
	236090 †	—	—	—	—	—	23602	23614 2 Pc.	1 Set
236090-10 †	—	—	—	—	—	23602-10	23614-10	Dyno-Pak 10 Sets	
<b>1983-95 302 ci 5.0 L</b>	 <p><b>Accu-Seal E</b> standard gasket materials, nitrile or silicone seals.</p> <p>* OEM-style 4-pc set w/ rubberized fiber rails (end seals not pictured).</p>								
	136090 *	13603	13600	13601	11106 <i>supersedes</i> 13606	13608	13602	—	1 Set
	36090-10 *	—	3600-10	3601-10	1106-10 <i>supersedes</i> 3606-10	3608-10	3602-10	—	Dyno-Pak 10 Sets
	 <p><b>Accu-Seal Pro</b> premium gasket materials, FKM seals.</p> <p>† 1-pc molded silicone. Steel backbone &amp; crush limiters.</p>								
	236090 †	—	—	—	—	—	23602	23604 2 Pc.	1 Set
236090-10 †	—	—	—	—	—	23602-10	23604-10	Dyno-Pak 10 Sets	

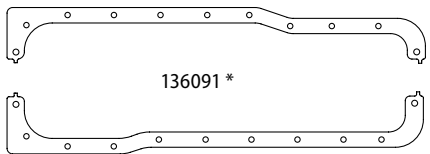
**Ford 289-351W Small Block V8 · Short Block Gaskets & Seals**

Application	Oil Pan Gasket Set	Timing Cover Gasket Set	Front Cover Gasket Set TC · WP · FP	Water Pump Gasket Set	Fuel Pump Gasket	Water Outlet Gasket	Timing Cover Oil Seal	Rear Main Oil Seal	Qty.
<b>1969-83 Windsor 351 ci 5.8 L</b>	 <p><b>Accu-Seal E</b> standard gasket materials, nitrile or silicone seals.</p> <p>* OEM-style 4-pc set w/ rubberized fiber rails (end seals not pictured).</p>								
	136091 *	13603	13600	13601	11106 <i>supersedes 13606</i>	13608	13602	13605 2 Pc.	1 Set
	36091-10 *	—	3600-10	3601-10	1106-10 <i>supersedes 3606-10</i>	3608-10	3602-10	3605-10	Dyno-Pak 10 Sets
	 <p><b>Accu-Seal Pro</b> premium gasket materials, FKM seals.</p> <p>† 1-pc molded silicone. Steel backbone &amp; crush limiters.</p>								
	236091 †	—	—	—	—	—	23602	23615 2 Pc.	1 Set
	236091-10 †	—	—	—	—	—	23602-10	23615-10	Dyno-Pak 10 Sets
<b>1983-98 Windsor 351 ci 5.8 L</b>	 <p><b>Accu-Seal E</b> standard gasket materials, nitrile or silicone seals.</p> <p>* OEM-style 4-pc set w/ rubberized fiber rails (end seals not pictured).</p>								
	136091 *	13603	13600	13601	11106 <i>supersedes 13606</i>	13608	13602	—	1 Set
	36091-10 *	—	3600-10	3601-10	1106-10 <i>supersedes 3606-10</i>	3608-10	3602-10	—	Dyno-Pak 10 Sets
	 <p><b>Accu-Seal Pro</b> premium gasket materials, FKM seals.</p> <p>† 1-pc molded silicone. Steel backbone &amp; crush limiters.</p>								
	236091 †	—	—	—	—	—	23602	23605 1 Pc.	1 Set
	236091-10 †	—	—	—	—	—	23602-10	23605-10	Dyno-Pak 10 Sets

**Ford 289-351W Small Block V8 · SBBK – Short Block Base Kit**

**NEW!**  
— SEE P. 8 —

Provides remaining gaskets & seals common to the engine type, regardless of customization.



Application	SBBK Gasket / Oil Seal Kit	Contents of Kit	
1963-83 289-302 ci 4.7-5.0 L	33603	<b>Includes:</b> Timing Cover · Water Pump · Fuel Pump · Water Outlet Gasket · Timing Cover Seal · 2-pc Rear Main Seal	
	43603	<b>Includes:</b> Timing Cover · Water Pump · Fuel Pump · Water Outlet Gasket · Timing Cover Seal · 2-pc FKM Rear Main Seal	
1969-83 351W ci 5.8 L	33604	<b>Includes:</b> Timing Cover · Water Pump · Fuel Pump · Water Outlet Gasket · Timing Cover Seal · 2-pc Rear Main Seal	
	43604	<b>Includes:</b> Timing Cover · Water Pump · Fuel Pump · Water Outlet Gasket · Timing Cover Seal · 2-pc FKM Rear Main Seal	
1983-01 302W ci 5.0 L	33605	<b>Includes:</b> Timing Cover · Water Pump · Fuel Pump · Water Outlet Gasket · Timing Cover Seal · 1-pc Rear Main Seal	
	43605	<b>Includes:</b> Timing Cover · Water Pump · Fuel Pump · Water Outlet Gasket · Timing Cover Seal · 1-pc FKM Rear Main Seal	

33603



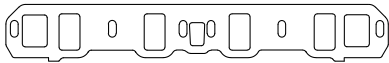
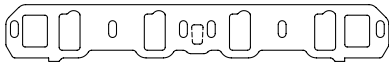
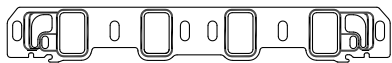
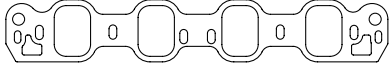

**Ford 289-351W V8 · Valve Cover Gaskets**

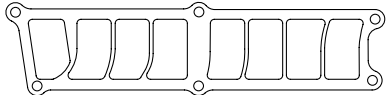
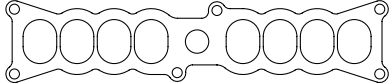
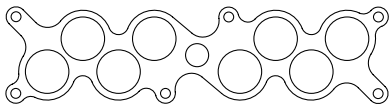
Application	<i>Molded</i> Silicone Rubber	Hi-Density Cork 5/16" Thick	<i>Tuff-Bak</i> Laminated Cork		Steel-Core PTFE-Coated .093" Thick (3/32")	Qty.
			1/8" Thick	1/4" Thick		
			Street / Strip			
1963-01 289-351W Windsor 289-351 ci 4.7-5.8 L			6 bolts, 3-over-3 pattern, fits all 'Windsor' style valve covers — * Steel frame with edge-molded silicone			
	236179 *	136076	236175	236176	236178	1 Set
	—	36076-10	236175-10	236176-10	236178-10	Dyno-Pak 10 Sets
1969-70 Boss 302 302 ci · 5.0 L			8 bolts, 4-over-4 pattern; fits Boss 302, SVO Yates & Blue Thunder 351C heads			
	—	152076	252175	252176	252178	1 Set
	—	52076-10	252175-10	252176-10	252178-10	Dyno-Pak 10 Sets

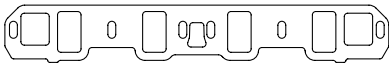
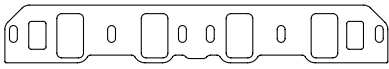

**Ford 260-351W Small Block V8 · Intake Gaskets**

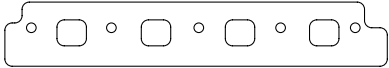
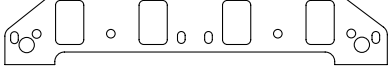
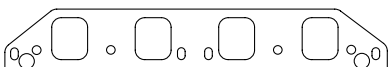
Application — Port Size	Thickness	Accu-Seal E Standard Material		Accu-Seal Pro · Premium Materials	
		Packaged 1 Set	Dyno-Pak · 10 Sets	Packaged 1 Set	Dyno-Pak · 10 Sets
<b>1962-01</b> <b>Stock Port</b> <b>260-351W</b> <b>4.3-5.8 L</b> — <b>1.07" x 2.00"</b> <b>Rectangle</b>	 <p>Also fits World Products Windsor and Windsor Aluminum. — † Silicone Bead Sealed Ports.</p>				
	.062"	136101	36101-10	236101 †	236101-10 †
	.120"	136106	36106-10	—	
<b>1986-01</b> <b>5.0L with EFI</b> <b>302 ci · 5.0 L</b> — <b>1.30" x 2.06"</b> <b>Rectangle</b>	 <p>Gaskets have allowance for injectors at top of ports, optional heat transfer. — † Silicone Bead Sealed Ports.</p>				
	.062"	136110	36110-10	236110 †	236110-10 †
	.120"	136113	36113-10	—	
<b>1968-80</b> <b>Large Port</b> <b>351W · 5.8 L</b> — <b>1.31" x 2.14"</b> <b>Rectangle</b>	 <p>Fit 351W cylinder heads with extra bolts in coolant ports. — † Silicone Bead Sealed Ports.</p>				
	.062"	136118	36118-10	236118 †	236118-10 †
<b>1969-70</b> <b>Boss 302</b> <b>302 ci · 5.0 L</b> — <b>1.90" x 2.66"</b> <b>Rectangle</b>					
	.062"	136114	36114-10	236114	236114-10
<b>1997-Up</b> <b>GT-40 / GT-40P</b> <b>302 ci · 5.0 L</b> — <b>1.30" x 2.14"</b> <b>Rectangle</b>	 <p>Also fits Motorsport N351 Sportsman, Edelbrock Victor Jr., TFS Twisted Wedge, &amp; Brodix T1F.</p>				
	.062"	136102	36102-10	236102	236102-10
<b>1986-01</b> <b>EFI Upper Manifold</b> <b>302 ci · 5.0 L</b> <b>Truck</b> — <b>Rectangle</b>	 <p>Inline rectangular ports. Also fits Holley® 5.0 L EFI intake.</p>				
	.062"	136119	136119-10	236119	236119-10
<b>1986-01</b> <b>EFI Upper Manifold</b> <b>302 ci · 5.0 L HO</b> — <b>Oval</b>	 <p>Inline oval ports</p>				
	.062"	136104	36104-10	236104	236104-10
<b>1997-Up</b> <b>GT-40 / GT-40P</b> <b>EFI Upper Manifold</b> <b>302 ci · 5.0 L</b> — <b>Round</b>	 <p>Staggered round ports.</p>				
	.062"	136105	36105-10	236105	236105-10



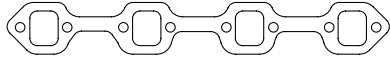

**302-351W Racing Derivatives - Intake Gaskets**

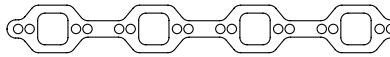
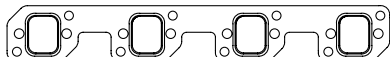
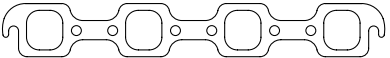
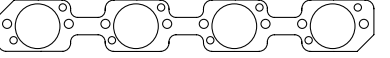
Application — Port Size	Thickness	Accu-Seal E Standard Material		Accu-Seal Pro · Premium Materials	
		Packaged 1 Set	Dyno-Pak · 10 Sets	Packaged 1 Set	Dyno-Pak · 10 Sets
<b>Windsor Medium Race Port</b> — <b>1.28" x 2.10" Rectangle</b>	 <p>Also fits World Products Windsor &amp; Windsor Aluminum. † Silicone Bead Sealed Ports.</p>				
	.062"	136116	36116-10	236116 †	236116-10 †
	.120"	136117	—	—	
<b>Trick Flow 'R' Series</b> — <b>1.37" x 2.30" Rectangle</b>					
	.062"	136108	36108-10	236108	236108-10
<b>Edelbrock Victor XL Port</b> — <b>1.50" x 2.24" Rectangle</b>	 <p>Fits 18° &amp; 15° Heads. † Silicone Bead Sealed Ports.</p>				
	.062"	136103	36103-10	236103 †	236103-10 †
<b>Blue Thunder 18-Bolt Trim-to-Fit</b>	 <p>Fits "as-cast ports"</p>				
	.062"	145101	45101-10	245101	245101-10
<b>SVO Yates C3</b> — <b>1.47" x 2.31" Rectangle</b>	 <p>Circle Track Ports.</p>				
	.062"	152107	52107-10	252107	252107-10
	.120"	152117	52117-10	—	
<b>SVO Yates C3 Large Port</b> — <b>1.85" x 2.22" Rectangle</b>	 <p>Drag Race Ports.</p>				
	.062"	152105	52105-10	252105	252105-10
	.120"	152109	52109-10	—	
<b>Roush-Yates D3</b> — <b>1.75" x 2.22" Rectangle</b>	 <p>Ford Motorsport "N" / Trick Flow "R".</p>				
	.062"	152111	152111-10	252111	252111-10

**Ford 260-351W Small Block V8 · Exhaust Gaskets**

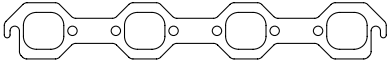
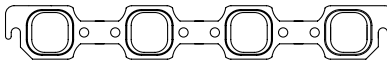
Application — Port Size	Accu-Seal E		Accu-Seal Pro		Graph-Form	Pro-Copper	
	Standard Material .062"		Premium Material .062"		Hi-Density Graphite .150"	Embossed .043"	Flat-Annealed .062"
	Packaged 1 Set	Dyno-Pak 10 Sets	Packaged 1 Set	Dyno-Pak 10 Sets	Packaged 1 Set	Packaged 1 Set	Packaged 1 Set
1962-01 260-351W 4.3-5.8 L — 1.20" x 1.47" Rectangle	 <p>Fits rectangle port headers with standard 2" bolt spread</p>						
	136081	36081-10	236181	36181-10	436181	4036	E36186
1962-01 260-351W 4.3-5.8 L — 1.70" x 1.77" Oval	 <p>Fits Flowtech, Hedman and similar oval port headers with standard bolt pattern</p>						
	136083	36083-10	236183	36183-10	436183	4936	—
1969-74 Boss 302 Head / 351C 4-Barrel 5.0-5.8 L — 1.79" x 2.05" Square	 <p>Notch top rectangle, also fits CHI 3V heads</p>						
	152080	52080-10	252180	52180-10	452180	4352	E52286
<b>Racing Derivatives</b>							
Dual Bolt-Pattern — 1.36" x 1.36" Square	 <p>Fits Dart, TFS, E351, Pro Topline F120-180, includes stock location &amp; wide bolt-pattern</p>						
	136087	36087-10	236187	36187-10	—	—	—
J302 / K302 AR Head — 1.20" x 1.47" Square	 <p>Dual bolt-pattern also fits Hooker adapter plate</p>						
	—	—	—	—	—	4536	—
SVO N351 Sportsman — 1.60" x 1.77" Square	 <p>Also fits Ford Performance Z &amp; Z2, Brodix T1F, bolt spread 2.770" across ports</p>						
	136082	36082-10	236182	36182-10	436182	4236	—
Trick Flow 'R' Series — 1.76" Round	 <p>Dual bolt pattern matches TFS 'R' heads, also fits Motorsport 'N' heads, seals 1.875" primary tube headers</p>						
	—	—	—	—	—	4436	—

**302-351W Small Block · Racing Derivatives · Exhaust Gaskets**

Application — Port Size	Accu-Seal E		Accu-Seal Pro		Graph-Form	Pro-Copper	
	Standard Material .062"		Premium Material .062"		Hi-Density Graphite .150"	Embossed .043"	Flat-Annealed .062"
	Packaged 1 Set	Dyno-Pak 10 Sets	Packaged 1 Set	Dyno-Pak 10 Sets	Packaged 1 Set	Packaged 1 Set	Packaged 1 Set
Trick Flow 'R' Series — 1.87" Round	 <p>Angled bolt pattern, seals 2" primary tube headers</p>						
	136084	36084-10	236184	36184-10	436184	4836	—
Edelbrock Victor 7219 — 1.75" x 1.60" Square	 <p>Fits square port headers, bolt spread 2.5" across ports</p>						
	136085	36085-10	236185	36185-10	—	4636	—
Windsor Wide Bolt-Pattern — 1.60" x 1.77" Square	 <p>Fits World, Dart Windsor, AFR 225 with 3" bolt-spread across ports</p>						
	136086	36086-10	236186	36186-10	—	4736	—
SVO C302 / B351 / Roush-Yates D3 — 1.87" Round	 <p>Seals 2" primary tube headers.</p>						
	152083	52083-10	252183	52183-10	—	4152	—
SVO Yates C3 — 2.00" x 1.75" Square							
	152081	52081-10	252181	52181-10	—	—	E52186
Blue Thunder 18-Bolt — 1.73" x 1.58" Square							
	145080	45080-10	245180	45180-10	—	4045	—

**Ford 260-351W Small Block V8**  
**MLS Spartan · Performance Head Gaskets**

Application	Image	Bore Opening	Compr. Thick.	Part Number	Description	Qty.
1962-01 260-351W 4.3-5.8 L		4.030"	.028"	M360328	MLS embossed stainless steel construction.	1
		4.040"	.039"	M360439		1
		4.100"	.039"	M361039		1
302-351W SVO Boss 302 4.3-5.8 L		4.100"	.039"	M391039L <i>Left</i>		1
		4.100"	.039"	M391039R <i>Right</i>		1
1986-01 302-351W 5.0-5.8 L		4.100"	.028"	M361028GS		MLS Spartan with <b>Gas-Stopper</b> embossed stainless steel construction.
		4.100"	.051"	M361051GS	1	
		4.155"	.039"	M361539GS	1	

**Marine Use:** stainless steel construction, all MLS Spartan head gaskets are suitable for use in marine applications.

**Ford Windsor Small Block · 302-351 ci · 5.0-5.8 L**

**Pro-Copper**  
**Racing Head Gaskets**

For use with o-rings & sealant

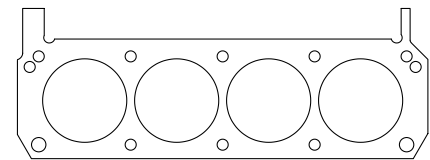
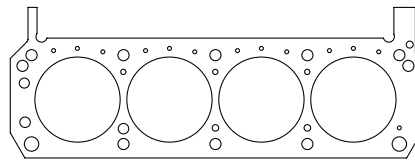

No water holes: use suffix "NW"

Bore Opening	Thickness								Qty.
	.021"	.032"	.043"	.050"	.062"	.072"	.080"	.093"	
4.010" round	P360021L P360021R	P360032L P360032R	P360043L P360043R	P360050L P360050R	P360062L P360062R	P360072L P360072R	P360080L P360080R	P360093L P360093R	1
4.060" round	P360621L P360621R	P360632L P360632R	P360643L P360643R	P360650L P360650R	P360662L P360662R	P360672L P360672R	P360680L P360680R	P360693L P360693R	1
4.135" round	P363521L P363521R	P363532L P363532R	P363543L P363543R	P363550L P363550R	P363562L P363562R	P363572L P363572R	P363580L P363580R	P363593L P363593R	1
4.160" round	P361521L P361521R	P361532L P361532R	P361543L P361543R	P361550L P361550R	P361562L P361562R	P361572L P361572R	P361580L P361580R	P361593L P361593R	1
4.200" round	P362021L P362021R	P362032L P362032R	P362043L P362043R	P362050L P362050R	P362062L P362062R	P362072L P362072R	P362080L P362080R	P362093L P362093R	1

**Titan & ICS on next page »**



**Ford Windsor Small Block • 302-351 ci • 5.0-5.8 L**

**Titan**

**Copper Racing Head Gaskets**

Sealed coolant passages, for use with o-rings & sealant

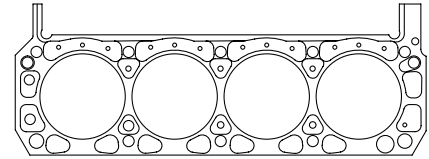

Bore Opening	Thickness								Qty.
	.021"	.032"	.043"	.050"	.062"	.072"	.080"	.093"	
4.010" round	—	T360032L T360032R	T360043L T360043R	T360050L T360050R	T360062L T360062R	T360072L T360072R	T360080L T360080R	T360093L T360093R	1
4.060" round	—	T360632L T360632R	T360643L T360643R	T360650L T360650R	T360662L T360662R	T360672L T360672R	T360680L T360680R	T360693L T360693R	1
4.135" round	—	T363532L T363532R	T363543L T363543R	T363550L T363550R	T363562L T363562R	T363572L T363572R	T363580L T363580R	T363593L T363593R	1
4.160" round	—	T361532L T361532R	T361543L T361543R	T361550L T361550R	T361562L T361562R	T361572L T361572R	T361580L T361580R	T361593L T361593R	1
4.200" round	—	T362032L T362032R	T362043L T362043R	T362050L T362050R	T362062L T362062R	T362072L T362072R	T362080L T362080R	T362093L T362093R	1

**ICS**

**Copper Racing Head Gaskets**

Sealed coolant passages, integral combustion o-ring

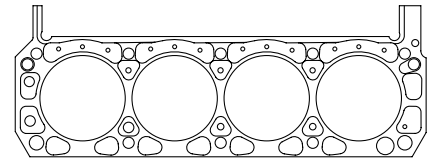

Bore Opening	Thickness								Qty.
	.021"	.032"	.043"	.050"	.062"	.072"	.080"	.093"	
4.010" round	—	—	S360043L S360043R	S360050L S360050R	S360062L S360062R	S360072L S360072R	S360080L S360080R	S360093L S360093R	1
4.060" round	—	—	S360643L S360643R	S360650L S360650R	S360662L S360662R	S360672L S360672R	S360680L S360680R	S360693L S360693R	1
4.135" round	—	—	S363543L S363543R	S363550L S363550R	S363562L S363562R	S363572L S363572R	S363580L S363580R	S363593L S363593R	1
4.160" round	—	—	S361543L S361543R	S361550L S361550R	S361562L S361562R	S361572L S361572R	S361580L S361580R	S361593L S361593R	1
4.200" round	—	—	No Fit: insufficient area between bores						

« Pro-Copper on previous page

**Windsor SB Racing Derivative • BMP Aluminum Man-O-War**

**Pro-Copper  
Racing Head Gaskets**

For use with o-rings & sealant

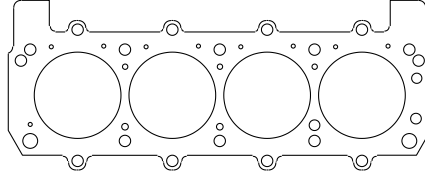

Bore Opening	Thickness								Qty.
	.021"	.032"	.043"	.050"	.062"	.072"	.080"	.093"	
4.060" round	–	P360632MW	P360643MW	P360650MW	P360662MW	P360672MW	P360680MW	P360693MW	1
4.135" round	–	P361332MW	P361343MW	P361350MW	P361362MW	P361372MW	P361380MW	P361393MW	1
4.160" round	–	P361632MW	P361643MW	P361650MW	P361662MW	P361672MW	P361680MW	P361693MW	1
4.180" round	–	P361832MW	P361843MW	P361850MW	P361862MW	P361872MW	P361880MW	P361893MW	1
4.200" round	–	P362032MW	P362043MW	P362050MW	P362062MW	P362072MW	P362080MW	P362093MW	1

**SVO Yates & Boss 302**

**Pro-Copper  
Racing Head Gaskets**

For use with o-rings & sealant

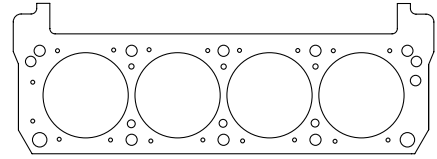

Bore Opening	Thickness								Qty.
	.021"	.032"	.043"	.050"	.062"	.072"	.080"	.093"	
4.010" round	P390021L P390021R	P390032L P390032R	P390043L P390043R	P390050L P390050R	P390062L P390062R	P390072L P390072R	P390080L P390080R	P390093L P390093R	1
4.060" round	P390621L P390621R	P390632L P390632R	P390643L P390643R	P390650L P390650R	P390662L P390662R	P390672L P390672R	P390680L P390680R	P390693L P390693R	1
4.130" round	P391321L P391321R	P391332L P391332R	P391343L P391343R	P391350L P391350R	P391362L P391362R	P391372L P391372R	P391380L P391380R	P391393L P391393R	1
4.160" round	P391521L P391521R	P391532L P391532R	P391543L P391543R	P391550L P391550R	P391562L P391562R	P391572L P391572R	P391580L P391580R	P391593L P391593R	1
4.180" round	P391821L P391821R	P391832L P391832R	P391843L P391843R	P391850L P391850R	P391862L P391862R	P391872L P391872R	P391880L P391880R	P391893L P391893R	1
4.200" round	P392021L P392021R	P392032L P392032R	P392043L P392043R	P392050L P392050R	P392062L P392062R	P392072L P392072R	P392080L P392080R	P392093L P392093R	1

**Titan  
Copper Racing Head Gaskets**

Sealed coolant passages, for use with o-rings & sealant

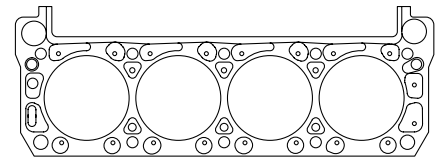

Bore Opening	Thickness								Qty.
	.021"	.032"	.043"	.050"	.062"	.072"	.080"	.093"	
4.010" round	—	T390032L T390032R	T390043L T390043R	T390050L T390050R	T390062L T390062R	T390072L T390072R	T390080L T390080R	T390093L T390093R	1
4.060" round	—	T390632L T390632R	T390643L T390643R	T390650L T390650R	T390662L T390662R	T390672L T390672R	T390680L T390680R	T390693L T390693R	1
4.160" round	—	T391532L T391532R	T391543L T391543R	T391550L T391550R	T391562L T391562R	T391572L T391572R	T391580L T391580R	T391593L T391593R	1
4.200" round	—	T392032L T392032R	T392043L T392043R	T392050L T392050R	T392062L T392062R	T392072L T392072R	T392080L T392080R	T392093L T392093R	1

**ICS  
Copper Racing Head Gaskets**

Sealed coolant passages, integral combustion o-ring

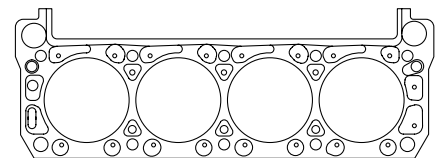

Bore Opening	Thickness								Qty.
	.021"	.032"	.043"	.050"	.062"	.072"	.080"	.093"	
4.010" round	—	—	S390043L S390043R	S390050L S390050R	S390062L S390062R	S390072L S390072R	S390080L S390080R	S390093L S390093R	1
4.060" round	—	—	S390643L S390643R	S390650L S390650R	S390662L S390662R	S390672L S390672R	S390680L S390680R	S390693L S390693R	1
4.160" round	—	—	S391543L S391543R	S391550L S391550R	S391562L S391562R	S391572L S391572R	S391580L S391580R	S391593L S391593R	1
4.200" round	—	—	No Fit: Insufficient area between bores						

**Ford 351C-400M · Short Block Gaskets & Seals**

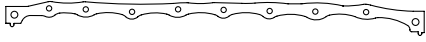
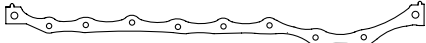
Application	Oil Pan Gasket Set	Timing Cover Gasket Set	Front Cover Gasket Set TC · WP · FP	Water Pump Gasket Set	Fuel Pump Gasket	Water Outlet Gasket	Timing Cover Oil Seal	Rear Main Oil Seal	Qty.
<b>1970-82 351C Cleveland &amp; 351-400M Modified 351-400 ci 5.8-6.6 L</b>	 <p>152090 *</p>  <p>52090-10 *</p> <p style="text-align: right;"><b>Accu-Seal E</b> standard gasket materials, nitrile or silicone seals.</p> <p style="text-align: right;">* OEM-style 4-pc set w/ rubberized fiber rails (end seals not pictured).</p>								
	152090 *	15203	15200	15201	15206	15208	13602	13605 2 Pc.	1 Set
	52090-10 *	—	5200-10	5201-10	5206-10	5208-10	3602-10	3605-10	Dyno-Pak 10 Sets
	<b>Accu-Seal Pro</b> premium gasket materials, FKM seals, molded water outlet.								
	—	—	—	—	—	—	—	23602	23615 2 Pc.
							23602-10	23615-10	Dyno-Pak 10 Sets

**Ford 351C-400M**

**NEW!**  
— SEE P. 8 —

**SBBK – Short Block Base Kit** · Provides remaining gaskets and seals common to the engine type, regardless of customization.

Application	SBBK Gasket / Oil Seal Kit	Contents of Kit
<b>1970-82 351C Cleveland &amp; 351-400M Modified 351-400 ci 5.8-6.6 L</b>	35203	<p><b>Includes:</b> Timing Cover · Water Pump · Fuel Pump · Water Outlet Gasket · Timing Cover Seal · 2-pc Rear Main Seal</p>
	45203	<p><b>Includes:</b> Timing Cover · Water Pump · Fuel Pump · Water Outlet Gasket · Timing Cover Seal · 2-pc FKM Rear Main Seal</p>

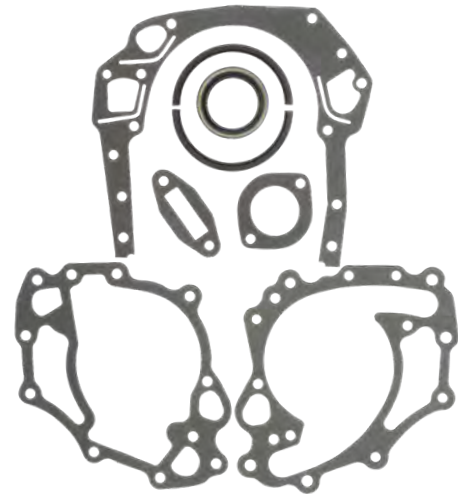



**Ford 351C-400M · Valve Cover Gaskets**

Application	Hi-Density Cork 3/16" Thick	Hi-Density Cork 5/16" Thick	Tuff-Bak Laminated Cork		Steel Core PTFE-Coated .093" Thick (3/32")	Qty.
	Street / Strip		1/8" Thick	1/4" Thick	Severe Duty™	
			Racing / Hi-Vac			
<b>1969-82 351C Cleveland</b> • <b>1969-70 Boss 302</b> • <b>351-400M Modified</b> • <b>5.8-6.6 L</b>			8 bolts, 4-over-4 pattern, also fits Boss 302, SVO Yates & Blue Thunder 351C heads			1 Set
						152075
	—	52076-10	252175-10	252176-10	252178-10	Dyno-Pak 10 Sets

**Ford 351C-400M · Intake Gaskets**

Application — Port Size	Thickness	Accu-Seal E Standard Material		Accu-Seal Pro · Premium Materials	
		Packaged 1 Set	Dyno-Pak · 10 Sets	Packaged 1 Set	Dyno-Pak · 10 Sets
<b>1969-82 351C-400M 2-Barrel 5.8-6.6 L</b> — <b>1.51" x 2.14" Oval</b>					
	.062"	152101	52101-10	252101	252101-10
<b>1969-82 Medium Race Port</b> — <b>1.60" x 2.27" Oval</b>					
	† Silicone Bead Sealed Ports				
	.062"	152102	52102-10	252102 †	252102-10 †
<b>1969-70 351C 4-Barrel 5.8 L</b> — <b>1.90" x 2.66" Rectangle</b>					
	† Silicone Bead Sealed Ports				
	.062"	152103	52103-10	252103 †	252103-10 †
<b>Blue Thunder 351C</b> — <b>1.60" x 2.10" Rectangle</b>					
	Fits finished heads as delivered from Blue Thunder				
<b>CHI-3V 185cc</b> — <b>1.50" x 1.85" Oval</b>					
	.062"	152110	152110-10	252110	252110-10
<b>CHI-3V 225cc</b> — <b>1.60" x 2.00" Oval</b>					
	.062"	152112	152112-10	252112	252112-10

**Ford 351C-400M V8 · Exhaust Gaskets**

Application — Port Size	Accu-Seal E		Accu-Seal Pro		Graph-Form	Pro-Copper	
	Standard Material .062"		Premium Material .062"		Hi-Density Graphite .150"	Embossed .043"	Flat-Annealed .062"
	Packaged 1 Set	Dyno-Pak 10 Sets	Packaged 1 Set	Dyno-Pak 10 Sets	Packaged 1 Set	Packaged 1 Set	Packaged 1 Set
<b>1969-82</b> <b>351C / 351M /</b> <b>400M</b> <b>2-Barrel</b> <b>5.8-6.6 L</b> — <b>1.35" x 1.87" Oval</b>	 <p style="text-align: right;">Fits stock 2 barrel oval port heads</p>						
	152082	52082-10	252182	52182-10	452182	4052	—
<b>1969-82</b> <b>351C / 351M /</b> <b>400M</b> <b>5.8-6.6 L</b> — <b>1.25" x 2.12" Oval</b>	 <p style="text-align: right;">2 barrel oval enlarged for ported heads</p>						
	—	—	—	—	—	4252	—
<b>1969-74</b> <b>351C 4-Barrel /</b> <b>Boss 302 Head</b> <b>5.0-5.8 L</b> — <b>1.79" x 2.05" Square</b>	 <p style="text-align: right;">Notch top rectangle, also fits CHI 3V heads.</p>						
	152080	52080-10	252180	52180-10	452180	4352	E52286

**Ford 351C, 351M, & 400M · 351-400 ci · 5.8-6.6 L**

**Pro-Copper  
Racing Head Gaskets**

For use with o-rings & sealant

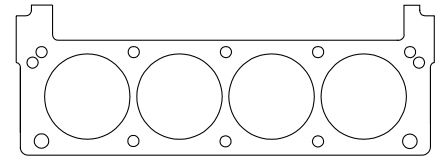
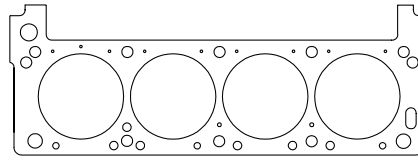

No water holes: use suffix "NW"

Bore Opening	Thickness								Qty.
	.021"	.032"	.043"	.050"	.062"	.072"	.080"	.093"	
4.010" round	P520021L P520021R	P520032L P520032R	P520043L P520043R	P520050L P520050R	P520062L P520062R	P520072L P520072R	P520080L P520080R	P520093L P520093R	1
4.060" round	P520621L P520621R	P520632L P520632R	P520643L P520643R	P520650L P520650R	P520662L P520662R	P520672L P520672R	P520680L P520680R	P520693L P520693R	1
4.130" round	P521321L P521321R	P521332L P521332R	P521343L P521343R	P521350L P521350R	P521362L P521362R	P521372L P521372R	P521380L P521380R	P521393L P521393R	1
4.160" round	P521521L P521521R	P521532L P521532R	P521543L P521543R	P521550L P521550R	P521562L P521562R	P521572L P521572R	P521580L P521580R	P521593L P521593R	1

**Titan  
Copper Racing Head Gaskets**

Sealed coolant passages, for use with o-rings & sealant

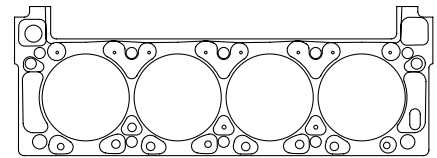

Bore Opening	Thickness								Qty.
	.021"	.032"	.043"	.050"	.062"	.072"	.080"	.093"	
4.010" round	-	T520032L T520032R	T520043L T520043R	T520050L T520050R	T520062L T520062R	T520072L T520072R	T520080L T520080R	T520093L T520093R	1
4.060" round	-	T520632L T520632R	T520643L T520643R	T520650L T520650R	T520662L T520662R	T520672L T520672R	T520680L T520680R	T520693L T520693R	1
4.160" round	-	T521532L T521532R	T521543L T521543R	T521550L T521550R	T521562L T521562R	T521572L T521572R	T521580L T521580R	T521593L T521593R	1

**ICS  
Copper Racing Head Gaskets**

Sealed coolant passages, integral combustion o-ring

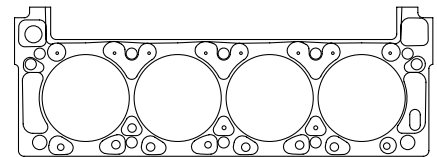

Bore Opening	Thickness								Qty.
	.021"	.032"	.043"	.050"	.062"	.072"	.080"	.093"	
4.160" round	-	-	S521543L S521543R	S521550L S521550R	S521562L S521562R	S521572L S521572R	S521580L S521580R	S521593L S521593R	1
4.200" round	-	-	S522043L S522043R	S522050L S522050R	S522062L S522062R	S522072L S522072R	S522080L S522080R	S522093L S522093R	1

**Ford Modular V8 - Short Block Gaskets & Seals**

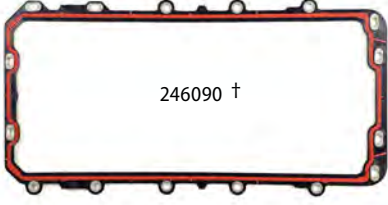
Application	Oil Pan Gasket Set	Timing Cover Gasket Set	Front Cover Gasket Set TC · WP · FP	Water Pump Gasket Set	Fuel Pump Gasket	Water Outlet Gasket	Timing Cover Oil Seal	Rear Main Oil Seal	Qty.
1996-Up 4.6-5.4 L Modular 281-330 ci	 <p style="text-align: center;">246090 †</p> <p style="text-align: right;"><b>Accu-Seal Pro</b> premium gasket materials, FKM seals, molded water outlet.</p> <p style="text-align: right;">† OEM-style 1-pc Plastic Carrier with silicone seal.</p>								
	246090 †	24603	-	-	-	24608	24602	23604 1 Pc.	1 Set
	246090-10 †	-	-	-	-	-	24602-10	-	Dyno-Pak 10 Sets

**Ford Modular V8 - Intake Gaskets**

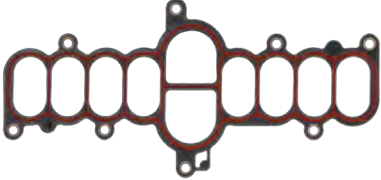
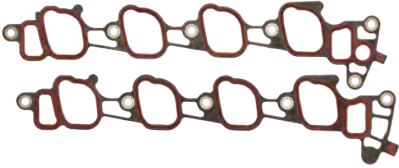
Application — Port Size	Thickness	Accu-Seal E Standard Material		Accu-Seal Pro · Premium Materials	
		Packaged 1 Set	Dyno-Pak · 10 Sets	Packaged 1 Set	Dyno-Pak · 10 Sets
1999-2004 4.6 L · SOHC Mustang GT Upper Manifold	 <p style="text-align: right;">Plastic Carrier, with Silicone Over-Mold at Ports</p>				
	.120"	-	-	211138	211138-10
1999-2004 4.6 L · SOHC Mustang GT Intake Manifold	 <p style="text-align: right;">Plastic Carrier, with Silicone Over-Mold at Ports</p>				
	.120"	-	-	246104	246104-10



**Ford Modular & Coyote V8 · Exhaust Gaskets**

Application — Port Size	Accu-Seal E		Accu-Seal Pro		Graph-Form	Pro-Copper	
	Standard Material .062"		Premium Material .062"		Hi-Density Graphite .150"	Embossed .043"	Flat-Annealed .062"
	Packaged 1 Set	Dyno-Pak 10 Sets	Packaged 1 Set	Dyno-Pak 10 Sets	Packaged 1 Set	Packaged 1 Set	Packaged 1 Set
<b>1991-Up Modular SOHC 2-Valve 281-330 ci 4.6-5.4 L</b> — <b>1.50" Round</b>			Fits stock manifolds & 1 5/8" primary tube headers for 1991-Up SOHC 2-valve engines				
	146080	46080-10	246180	46180-10	446180	4046	—
<b>1991-Up Modular DOHC 4-Valve 281-330 ci 4.6-5.4 L</b> — <b>1.25" x 2.12" Oval</b>			Fits BBK 1532, 1533 and similar oval port headers for 4-valve heads				
	146081	46081-10	246181	46181-10	446181	4146	—
<b>2005-Up Modular SOHC 3-Valve 281-330 ci 4.6-5.4 L</b> — <b>1.50" Round</b>			Fits 2005-Up 3-valve engines.				
	146082	46082-10	246182	46182-10	446182	4246	—
<b>2011-Up 5.0L Coyote DOHC 302 ci · 5.0 L</b> — <b>2.00" Round</b>			Fits 2011-Up 5.0L Coyote DOHC engines.				
	—	—	—	—	—	4047	—

**Ford Modular 4.6-5.4L V8 · MLS Spartan · Performance Head Gaskets**

Application	Image	Bore Opening	Compr. Thick.	Part Number	Description	Qty.
<b>1991-Up GEN 1 281-330 ci 4.6-5.4 L</b>		3.630"	.039"	M466339L <i>Left</i>	MLS Spartan embossed stainless steel construction.	1
		3.630"	.039"	M466339R <i>Right</i>		1
<b>Marine Use:</b> stainless steel construction, all MLS Spartan head gaskets are suitable for use in marine applications.						

**Ford Coyote / Voodoo V8 · *MLS Spartan* · Performance Head Gaskets**

Application	Image	Bore Opening	Compr. Thick.	Part Number	Description	Qty.
2011-14 GEN 1 2015-17 GEN 2 Coyote 5.0 L 302 ci • 2017-2020 GEN 2 Voodoo 5.2 L 317 ci  <i>Accommodates 13mm studs &amp; smaller. Gen 2 oil-passages are backward-compatible with Gen 1.</i>		3.756"	.039"	M477539V2L <i>Left</i>	MLS Spartan embossed stainless steel construction.	1
				M477539V2R <i>Right</i>		1
<p><b>Marine Use:</b> stainless steel construction, all MLS Spartan head gaskets are suitable for use in marine applications.</p>						

**Ford Coyote / Voodoo V8 · *Vulcan Cut-Ring* · Performance Head Gaskets**

Application	Image	Bore Opening	Compr. Thick.	Part Number	Description	Qty.
2011-14 GEN 1 2015-17 GEN 2 Coyote 5.0 L 302 ci • 2017-2020 GEN 2 Voodoo 5.2 L 317 ci  <i>Accommodates 13mm studs &amp; smaller. Gen 2 oil-passages are backward-compatible with Gen 1.</i>		3.669"	.039"	CR476739L <i>Left</i>	Stainless steel Cut-Ring combustion seals (not pictured).  Composite gasket body construction.	1
		3.669"		CR476739R <i>Right</i>		1
		3.716"	.039"	CR477139L <i>Left</i>	Stainless steel Cut-Ring combustion seals (not pictured).  Composite gasket body construction.	1
		3.716"		CR477139R <i>Right</i>		1

**Ford Modular V8 · 4.6-5.4 L · 281-330 ci**

**Pro-Copper  
Racing Head Gaskets**

For use with o-rings & sealant

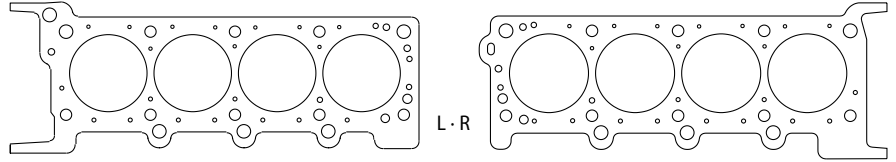

Bore Opening	Thickness								Qty.
	.021"	.032"	.043"	.050"	.062"	.072"	.080"	.093"	
3.625" round	P466221L P466221R	P466232L P466232R	P466243L P466243R	P466250L P466250R	P466262L P466262R	P466272L P466272R	P466280L P466280R	P466293L P466293R	1
3.750" round	P467521L P467521R	P467532L P467532R	P467543L P467543R	P467550L P467550R	P467562L P467562R	P467572L P467572R	P467580L P467580R	P467593L P467593R	1

**Titan  
Copper Racing  
Head Gaskets**

Sealed coolant passages,  
for use with o-rings & sealant

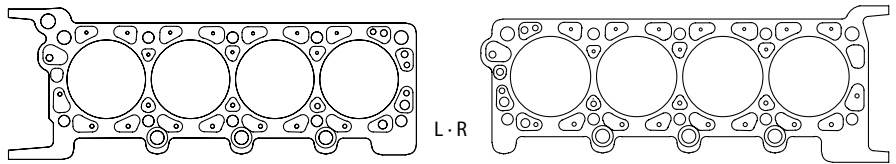

Bore Opening	Thickness								Qty.
	.021"	.032"	.043"	.050"	.062"	.072"	.080"	.093"	
3.625" round	—	T466232L T466232R	T466243L T466243R	T466250L T466250R	T466262L T466262R	T466272L T466272R	T466280L T466280R	T466293L T466293R	1
3.750" round	—	T467532L T467532R	T467543L T467543R	T467550L T467550R	T467562L T467562R	T467572L T467572R	T467580L T467580R	T467593L T467593R	1

**ICS  
Copper Racing  
Head Gaskets**

Sealed coolant passages,  
integral combustion o-ring

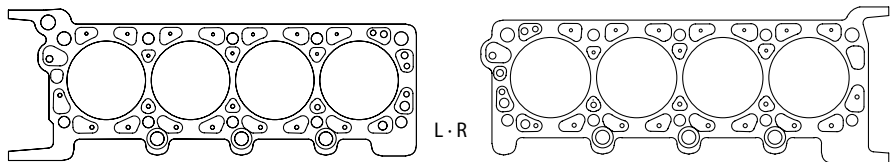

Bore Opening	Thickness								Qty.
	.021"	.032"	.043"	.050"	.062"	.072"	.080"	.093"	
3.625" round	—	—	S466243L S466243R	S466250L S466250R	S466262L S466262R	S466272L S466272R	S466280L S466280R	S466293L S466293R	1
3.750" round	—	—	S467543L S467543R	S467550L S467550R	S467562L S467562R	S467572L S467572R	S467580L S467580R	S467593L S467593R	1

**Ford Coyote V8 · GEN 1 & 2 · 302, 315 ci · 5.0-5.2 L**

**Pro-Copper  
Racing Head Gaskets**

For use with o-rings & sealant

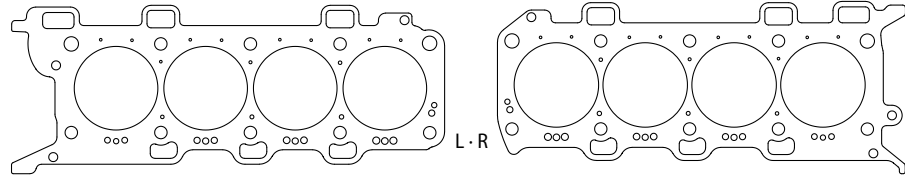

Bore Opening	Thickness								Qty.
	.021"	.032"	.043"	.050"	.062"	.072"	.080"	.093"	
3.720" round	P477221L P477221R	P477232L P477232R	P477243L P477243R	P477250L P477250R	P477262L P477262R	P477272L P477272R	P477280L P477280R	P477293L P477293R	1

**Titan  
Copper Racing  
Head Gaskets**

Sealed coolant passages,  
for use with o-rings & sealant

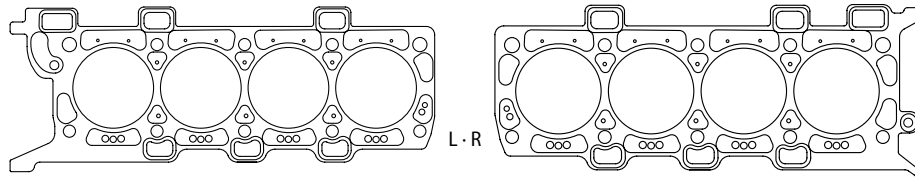

Bore Opening	Thickness								Qty.
	.021"	.032"	.043"	.050"	.062"	.072"	.080"	.093"	
3.720" round	—	T477232L T477232R	T477243L T477243R	T477250L T477250R	T477262L T477262R	T477272L T477272R	T477280L T477280R	T477293L T477293R	1

**ICS  
Copper Racing  
Head Gaskets**

Sealed coolant passages,  
integral combustion o-ring

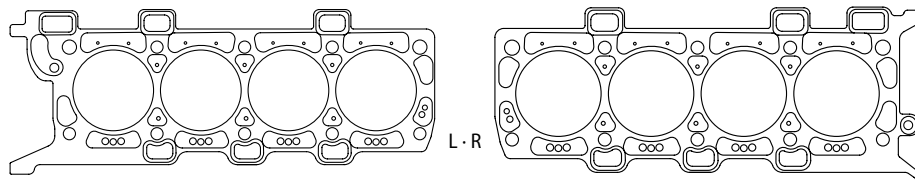

Bore Opening	Thickness								Qty.
	.021"	.032"	.043"	.050"	.062"	.072"	.080"	.093"	
3.720" round	—	—	S477243L S477243R	S477250L S477250R	S477262L S477262R	S477272L S477272R	S477280L S477280R	S477293L S477293R	1

All above parts accomodate 13mm studs & smaller. Gen 2 oil-passages are backward-compatible with Gen 1.

**Ford FE 352-428 V8 · Short Block Gaskets & Seals**

Application	Oil Pan Gasket Set	Timing Cover Gasket Set	Front Cover Gasket Set TC · WP · FP	Water Pump Gasket Set	Fuel Pump Gasket	Water Outlet Gasket	Timing Cover Oil Seal	Rear Main Oil Seal	Qty.
1958-77 352-428 ci 5.8-7.0 L	<p style="text-align: center;">134090 *</p> <p style="text-align: right;"><b>Accu-Seal E</b> standard gasket materials, nitrile or silicone seals. — * OEM-style 1-pc gasket, rubberized fiber material.</p>								
	134090 *	13403	13400	13401	13406	13408	13402	13405	1 Set
	34090-10 *	—	3400-10	3401-10	3406-10	3408-10	3402-10	3405-10	Dyno-Pak 10 Sets

**Ford FE 352-428 V8 · SBBK – Short Block Base Kit**

Provides remaining gaskets & seals common to the engine type, regardless of customization.



**NEW!**  
— SEE P.8 —

Application	SBBK Gasket/Oil Seal Kit	Contents of Kit	
1958-77 352-428 ci 5.8-7.0 L	33403	<p><b>Includes:</b> Timing Cover · Water Pump · Fuel Pump · Water Outlet Gasket · Timing Cover Seal · Main Cap Side Seals · 2-pc Rear Main Seal</p>	

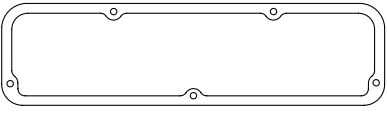
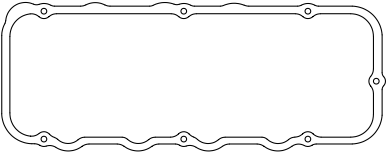
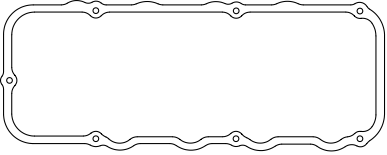
**Ford FE 352-428 V8 · Valve Cover Gaskets**

Application	Hi-Density Cork 3/16" Thick	Hi-Density Cork 5/16" Thick	Tuff-Bak Laminated Cork		Steel-Core PTFE-Coated .093" Thick	Qty.	
	Street / Strip		1/8" Thick	1/4" Thick			Racing / Hi-Vac
<b>1958-77 352-428 ci 5.8-7.0 L</b>  except SOHC			5 Bolts, 2-over-3, fits all wedge head 'FE' engines			-	1 Set
							134075
<b>427 SOHC</b>					-	1 Set Left & Right	
						-	-

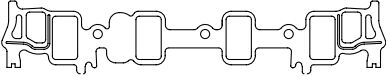
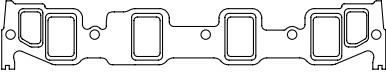
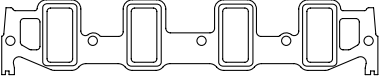
**Ford FE 352-428 V8 · Intake Gaskets**

Application — Port Size	Thickness	Accu-Seal E Standard Material		Accu-Seal Pro · Premium Materials		
		Packaged 1 Set	Dyno-Pak · 10 Sets	Packaged 1 Set	Dyno-Pak · 10 Sets	
<b>1958-76 Low Riser 390-428 ci 6.4-7.0 L</b>  1.42" x 2.40" Rect.						Fits early 352-390ci with low-riser manifold. * Hi-density composite material, non-metal core. † Coated Body, Silicone Bead Sealed Ports, Perforated Metal Core.
	.032"	134105 *	134105-10 *	-	-	
	.062"	134100	34100-10	234100 †	234100-10 †	
<b>1958-76 Medium Riser 390-428 ci 6.4-7.0 L</b>  1.40" x 2.10" Rect.						Also fits Edelbrock Performer RPM FE. * Hi-density composite material, non-metal core. † Coated Body, Silicone Bead Sealed Ports, Perforated Metal Core.
	.032"	134106 *	134106-10 *	-	-	
	.062"	134101	34101-10	234101 †	234101-10 †	
<b>1958-76 High Riser 390-428 ci 6.4-7.0 L</b>  2.72" x 1.34" Rect.						Fits Ford HP Heads. † Coated Body, Silicone Bead Sealed Ports, Perforated Metal Core.
	.062"	134103	134103-10	234103 †	234103-10 †	
<b>Blue Thunder 'FE' Small Bore High Riser</b>  1.40" x 2.11" Rect.						Perforated Metal Core.
	.062"	134102	34102-10	-	-	

**Ford FE 352-428 V8 · Exhaust Gaskets**

Application — Port Size	Accu-Seal E		Accu-Seal Pro		Graph-Form	Pro-Copper	
	Standard Material .062"		Premium Material .062"		Hi-Density Graphite .150"	Embossed .043"	Flat-Annealed .062"
	Packaged 1 Set	Dyno-Pak 10 Sets	Packaged 1 Set	Dyno-Pak 10 Sets	Packaged 1 Set	Packaged 1 Set	Packaged 1 Set
<b>1958-77</b> <b>352-428 ci</b> <b>Fits 8, 14 &amp; 16</b> <b>Bolt Flanges</b> <b>5.8-7.0 L</b> <b>—</b> <b>1.40" x 2.06"</b> <b>Rectangle</b>	<p>Ports are <b>.592"</b> below bolt center</p>		Universal 16-bolt pattern. For correct port fit, measure port height relative to top bolt. Ports are <b>.592</b> below bolt center.				
	134080	34080-10	234080	234080-10	434080	4034	—
	<p>Ports are <b>.742"</b> below bolt center</p>		Universal 16-bolt pattern. For correct port fit, measure port height relative to top bolt. Ports are <b>.742</b> below bolt center.				
	—	—	—	—	—	4134	—
<p>Ports are <b>.867"</b> below bolt center</p>		Universal 16-bolt pattern. For correct port fit, measure port height relative to top bolt. Ports are <b>.867</b> below bolt center.					
—		—		—		4234	—
<b>1958-77</b> <b>352-428 ci</b> <b>5.8-7.0 L</b> <b>—</b> <b>1.32" x 1.86"</b> <b>Rectangle</b>			8-bolt pattern. Fits most low-riser & medium-riser heads. OEM-style steel-back material.				
	134081	134081-10	—	—	—	—	—

**Ford 352-428 FE**  
**Accu-Seal Pro · Performance Head Gaskets**

Application	Image	Bore Opening	Compr. Thick.	Part Number	Description	Qty.
1958-77 352-428 ci Standard Bore FE Engines 5.8-7.0 L		4.250"	.020"	5342520	Embossed steel shim construction.	1
1958-77 390-428 ci Large Bore FE Engines 5.8-7.0 L	 Special "Folded" Combustion Seal for High- Performance Use	4.400"	.020"	5344020		1

**Ford 352-428 FE · MLS Spartan · Performance Head Gaskets**

Application	Image	Bore Opening	Compr. Thick.	Part Number	Description	Qty.
1958-77 390-428 ci Large Bore FE Engines 5.8-7.0 L		4.325"	.039"	M343239	MLS embossed stainless steel construction.	1
		4.400"	.039"	M344039		1

**Marine Use:** stainless steel construction, all MLS Spartan head gaskets are suitable for use in marine applications.



**Ford FE • 352-428 ci • 5.8-7.0 L**

**Pro-Copper  
Racing Head Gaskets**

For use with o-rings & sealant

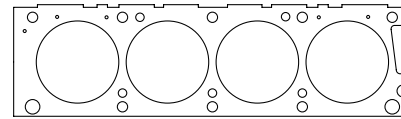

Includes oil-drain-back hole for 427 SOHC

Bore Opening	Thickness								Qty.
	.021"	.032"	.043"	.050"	.062"	.072"	.080"	.093"	
4.160" round <i>except 427</i>	P341521L P341521R	P341532L P341532R	P341543L P341543R	P341550L P341550R	P341562L P341562R	P341572L P341572R	P341580L P341580R	P341593L P341593R	1
4.200" round <i>except 427</i>	P342021L P342021R	P342032L P342032R	P342043L P342043R	P342050L P342050R	P342062L P342062R	P342072L P342072R	P342080L P342080R	P342093L P342093R	1
4.250" round	P342521L P342521R	P342532L P342532R	P342543L P342543R	P342550L P342550R	P342562L P342562R	P342572L P342572R	P342580L P342580R	P342593L P342593R	1
4.320" round	P343221L P343221R	P343232L P343232R	P343243L P343243R	P343250L P343250R	P343262L P343262R	P343272L P343272R	P343280L P343280R	P343293L P343293R	1

**Titan  
Copper Racing Head Gaskets**

Sealed coolant passages, for use with o-rings & sealant

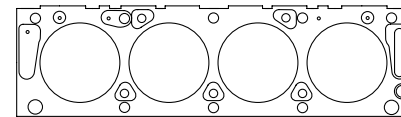

Includes oil-drain-back hole for 427 SOHC

Bore Opening	Thickness								Qty.
	.021"	.032"	.043"	.050"	.062"	.072"	.080"	.093"	
4.160" round <i>except 427</i>	-	T341532L T341532R	T341543L T341543R	T341550L T341550R	T341562L T341562R	T341572L T341572R	T341580L T341580R	T341593L T341593R	1
4.200" round <i>except 427</i>	-	T342032L T342032R	T342043L T342043R	T342050L T342050R	T342062L T342062R	T342072L T342072R	T342080L T342080R	T342093L T342093R	1
4.250" round	-	T342532L T342532R	T342543L T342543R	T342550L T342550R	T342562L T342562R	T342572L T342572R	T342580L T342580R	T342593L T342593R	1
4.320" round	-	T343232L T343232R	T343243L T343243R	T343250L T343250R	T343262L T343262R	T343272L T343272R	T343280L T343280R	T343293L T343293R	1

**ICS  
Copper Racing Head Gaskets**

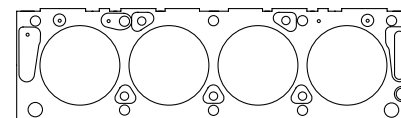

Sealed coolant passages, integral combustion o-ring



Includes oil-drain-back hole for 427 SOHC

Bore Opening	Thickness								Qty.
	.021"	.032"	.043"	.050"	.062"	.072"	.080"	.093"	
4.160" round <i>except 427</i>	-	-	S341543L S341543R	S341550L S341550R	S341562L S341562R	S341572L S341572R	S341580L S341580R	S341593L S341593R	1
4.200" round <i>except 427</i>	-	-	S342043L S342043R	S342050L S342050R	S342062L S342062R	S342072L S342072R	S342080L S342080R	S342093L S342093R	1
4.250" round	-	-	S342543L S342543R	S342550L S342550R	S342562L S342562R	S342572L S342572R	S342580L S342580R	S342593L S342593R	1
4.320" round	-	-	S343243L S343243R	S343250L S343250R	S343262L S343262R	S343272L S343272R	S343280L S343280R	S343293L S343293R	1

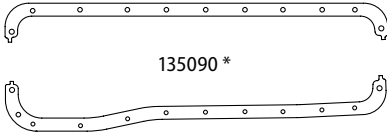
**Ford 429-460 Big Block V8 · Short Block Gaskets & Seals**

Application	Oil Pan Gasket Set	Timing Cover Gasket Set	Front Cover Gasket Set TC · WP · FP	Water Pump Gasket Set	Fuel Pump Gasket	Water Outlet Gasket	Timing Cover Oil Seal	Rear Main Oil Seal	Qty.
<b>1968-98 429-460 ci 7.0-7.5 L</b>	 <p><b>Accu-Seal E</b> standard gasket materials, nitrile or silicone seals.</p> <p>* OEM-style 4-pc set w/ rubberized fiber rails (end seals not pictured).</p>								
	135090 *	13503	—	13501	13506	13508	13502	13505 2 Pc.	1 Set
	35090-10 *	—	—	3501-10	3506-10	3508-10	3502-10	3505-10	Dyno-Pak 10 Sets
	 <p><b>Accu-Seal Pro</b> premium gasket materials, FKM seals,</p> <p>† 1-pc molded silicone with crush limiters.</p>								
	235091 †	—	—	—	—	—	23502	23505 2 Pc.	1 Set
235091-10 †	—	—	—	—	—	23502-10	23505-10	Dyno-Pak 10 Sets	

**NEW!**  
— SEE P.8 —

**Ford 429-460 Big Block V8 · SBBK – Short Block Base Kit**

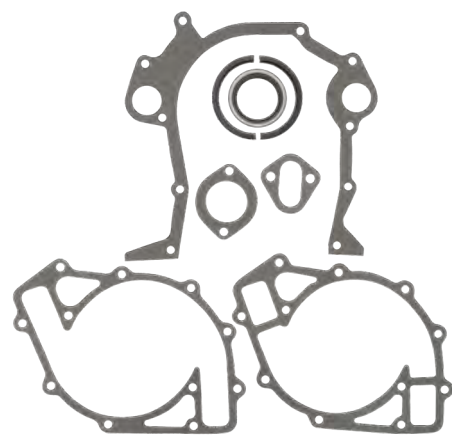

Provides remaining gaskets and seals common to the engine type, regardless of customization.

Application	SBBK Gasket/Oil Seal Kit	Contents of Kit
<b>1968-98 429, 460 ci 7.0-7.5 L</b>	33503	<p><b>Includes:</b> Timing Cover · Water Pump · Fuel Pump · Water Outlet Gasket · Timing Cover Seal · 2-pc Rear Main Seal</p> 

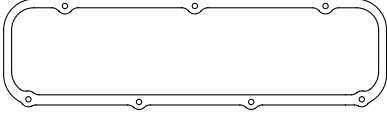
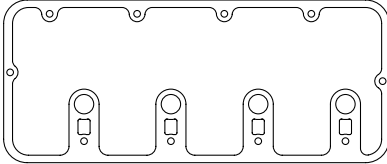

### Ford 429-460 Big Block V8 · Valve Cover Gaskets

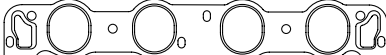
Application	<i>Molded</i> Silicone Rubber	Hi-Density Cork		<i>Tuff-Bak</i> Laminated Cork		Steel-Core PTFE-Coated .093" Thick (3/32")	Qty.
		3/16" Thick	5/16" Thick	1/8" Thick	1/4" Thick		
		Street / Strip		Racing / Hi-Vac		Severe Duty™	
1968-98 429-460 ci 7.0-7.5 L except Boss	 <p>7 bolts, 3-over-4, fits all wedge head Ford big blocks</p>						
	235179	135075	135076	235175	235176	235178	1 Set
	—	35075-10	35076-10	235175-10	235176-10	—	Dyno-Pak 10 Sets
1969-70 Boss 429 7.0 L	 <p>Fits only Boss 429</p>						
	—	—	—	248075	—	—	1 Set
	—	—	—	248075-10	—	—	Dyno-Pak 10 Sets

### Ford 429-460 Big Block V8 · Intake Gaskets

Application — Port Size	Thickness	Accu-Seal E Standard Material		<i>Accu-Seal Pro</i> · Premium Materials	
		Packaged 1 Set	Dyno-Pak · 10 Sets	Packaged 1 Set	Dyno-Pak · 10 Sets
1968-98 Standard Port 429-460 ci 7.0-7.5 L — 1.87" x 2.26" Oval	 <p>Fits non-CJ stock port factory iron heads &amp; similar aftermarket aluminum heads — † Silicone Bead Sealed Ports</p>				
	.062"	135101	35101-10	235101 †	235101-10 †
	.120"	135113	35113-10	—	
1969-71 Cobra Jet & SCJ 429 ci · 7.0 L — 2.22" x 2.60" Oval	 <p>Fits Ford Racing CJ, SCJ and similar aftermarket heads — † Silicone Bead Sealed Ports</p>				
	.062"	135102	35102-10	235102 †	235102-10 †
	.120"	135112	35112-10	—	
1969-70 Boss 429 429 ci · 7.0 L — 2.50" Round	 <p>Fits only Boss 429</p>				
	.062"	148101	148101-10	248101	248101-10

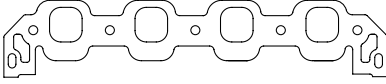
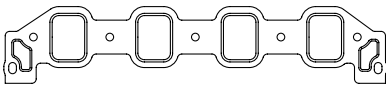
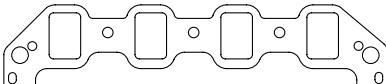
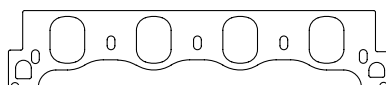
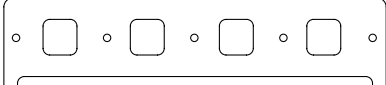
**Ford 460 Racing Derivatives · Intake Gaskets**

Application — Port Size	Thickness	Accu-Seal E Standard Material		Accu-Seal Pro · Premium Materials	
		Packaged 1 Set	Dyno-Pak · 10 Sets	Packaged 1 Set	Dyno-Pak · 10 Sets
<b>Ford Racing B460</b> — <b>1.80" x 1.95" Square</b>					
	.062"	135103	35103-10	235103	235103-10
	.120"	135109	35109-10	—	
<b>Ford Racing A460</b> — <b>1.85" x 2.55" Rectangle</b>	 <p>Fits early and late Ford Racing A460, also fits Trick Flow A460 — † Silicone Bead Sealed Ports</p>				
	.062"	135104	35104-10	235104 †	235104-10 †
	.120"	135106	35106-10	—	
<b>Ford Racing C460 Wedge</b> — <b>1.80" x 2.60" Rectangle</b>					
	.062"	135105	35105-10	235105	235105-10
	.120"	135108	35108-10	—	
<b>Profiler C460 205 Series</b> — <b>1.96" x 2.67" Oval</b>					
	.062"	135107	35107-10	235107	235107-10
<b>Ford Pro Stock Racing Hemi Trim-to-Fit</b> — <b>1.90" x 2.00" Square</b>	 <p>Fits "as cast ports" trim-to-fit</p>				
	.062"	137110	37110-10	237110	237110-10
<b>Raised Port Intake Blank Trim-to-Fit</b>					
	.062"	118100	18100-10	218100	218100-10
	.120"	118125	18125-10	—	

## Ford 429 · 460 Big Block V8 · Exhaust Gaskets

Application — Port Size	Accu-Seal E		Accu-Seal Pro		Graph-Form	Pro-Copper	
	Standard Material .062"		Premium Material .062"		Hi-Density Graphite .150"	Embossed .043"	Flat-Annealed .062"
	Packaged 1 Set	Dyno-Pak 10 Sets	Packaged 1 Set	Dyno-Pak 10 Sets	Packaged 1 Set	Packaged 1 Set	Packaged 1 Set
<b>1968-86</b> <b>429-460 ci</b> <b>7.0-7.5 L</b> — <b>1.25" x 2.12" Oval</b>			Fits small oval-port wedge heads from 1968-86. Does not fit large-oval CJ heads.				
	135080	35080-10	235180	35180-10	435180	4035	—
<b>1987-97</b> <b>EFI</b> <b>460 ci · 7.5 L</b> — <b>1.57" x 2.0"</b> <b>Rectangular</b> · <b>1.44" x 1.47"</b> <b>Square</b>			Composite gasket sets include designs to fit both of the 2 EFI manifold designs used from 1987-97, rectangular & square.  Each composite part number includes 2 Sets, 4 Pcs				
	135083	35083-10	235183	35183-10	435183	See Below	—
			4135	Embossed copper exhaust gaskets should be matched to the manifold, see illustrations at left.			4135 Rect. 1 set, 2 pcs
		4235				4235 Square 1 set, 2 pcs	
<b>1970-73</b> <b>429 CJ / SCJ</b> <b>429-460 ci</b> <b>7.0-7.5 L</b> — <b>1.52" x 2.50"</b> <b>Oval</b>			Also fits Ford Racing 460 Sportsman cylinder heads				
	135081	35081-10	235181	35181-10	435181	—	E35286
<b>1969-70</b> <b>Boss 429</b> — <b>1.52" x 2.50"</b> <b>D-port</b>							
	148081	48081-10	248181	48181-10	448181	—	—
<b>Racing Derivatives</b>							
<b>Trick Flow Head</b> <b>A460</b> — <b>2.70" Round</b>			Trick Flow A460 has rounded-flat floor ports & uses the BBC 4.840" port spread and bolt pattern				
	135084	35084-10	235184	35184-10	—	4213	E18186
<b>Ford Racing</b> <b>A460, C460, D460</b> — <b>2.17" x 2.02"</b> <b>Square</b>			1984-99 Ford Racing design with 4.900" centers, rectangle ports and unique bolt pattern				
	135085	35085-10	235185	35185-10	—	—	E35187
<b>Ford Racing A460</b> — <b>2.02" x 2.07"</b> <b>Square</b>			2000 & later Ford Racing design A460 with 4.900" centers, rectangle ports and BBC bolt pattern at the ports				
	135082	35082-10	235182	35182-10	—	—	—

**Ford 429 · 460 Big Block V8 · *MLS Spartan* · Performance Head Gaskets**

Application	Image	Bore Opening	Compr. Thick.	Part Number	Description	Qty.
1968-98 429-460 ci 7.0-7.5 L		4.400"	.039"	M354039	MLS Spartan embossed stainless steel construction.	1
		4.500"	.039"	M355039		1
<b>Marine Use:</b> stainless steel construction, all MLS Spartan head gaskets are suitable for use in marine applications.						

**Ford Big Block Wedge · 429-460 ci · 7.0-7.5 L**

***Pro-Copper*  
Racing Head Gaskets**

For use with o-rings & sealant

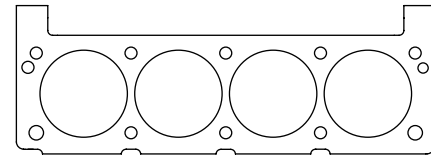
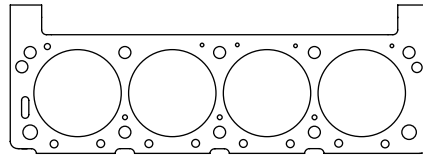

No water holes: use suffix "NW"

Bore Opening	Thickness								Qty.
	.021"	.032"	.043"	.050"	.062"	.072"	.080"	.093"	
4.380" round	P353821L P353821R	P353832L P353832R	P353843L P353843R	P353850L P353850R	P353862L P353862R	P353872L P353872R	P353880L P353880R	P353893L P353893R	1
4.440" round	P354421L P354421R	P354432L P354432R	P354443L P354443R	P354450L P354450R	P354462L P354462R	P354472L P354472R	P354480L P354480R	P354493L P354493R	1
4.520" round	P355221L P355221R	P355232L P355232R	P355243L P355243R	P355250L P355250R	P355262L P355262R	P355272L P355272R	P355280L P355280R	P355293L P355293R	1
4.570" round	P355721L P355721R	P355732L P355732R	P355743L P355743R	P355750L P355750R	P355762L P355762R	P355772L P355772R	P355780L P355780R	P355793L P355793R	1
4.630" round	P356221L P356221R	P356232L P356232R	P356243L P356243R	P356250L P356250R	P356262L P356262R	P356272L P356272R	P356280L P356280R	P356293L P356293R	1

***Titan*  
Copper Racing Head Gaskets**

Sealed coolant passages, for use with o-rings & sealant

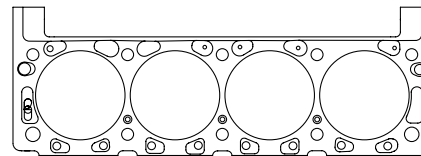

Bore Opening	Thickness								Qty.
	.021"	.032"	.043"	.050"	.062"	.072"	.080"	.093"	
4.380" round	—	T353832L T353832R	T353843L T353843R	T353850L T353850R	T353862L T353862R	T353872L T353872R	T353880L T353880R	T353893L T353893R	1
4.440" round	—	T354432L T354432R	T354443L T354443R	T354450L T354450R	T354462L T354462R	T354472L T354472R	T354480L T354480R	T354493L T354493R	1
4.520" round	—	T355232L T355232R	T355243L T355243R	T355250L T355250R	T355262L T355262R	T355272L T355272R	T355280L T355280R	T355293L T355293R	1
4.570" round	—	T355732L T355732R	T355743L T355743R	T355750L T355750R	T355762L T355762R	T355772L T355772R	T355780L T355780R	T355793L T355793R	1
4.630" round	—	T356232L T356232R	T356243L T356243R	T356250L T356250R	T356262L T356262R	T356272L T356272R	T356280L T356280R	T356293L T356293R	1

**ICS on next page »**

**Ford Big Block Wedge · 429-460 ci · 7.0-7.5 L**

**ICS**

**Copper Racing Head Gaskets**

Sealed coolant passages, integral combustion o-ring

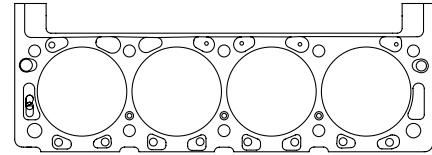

Bore Opening	Thickness								Qty.
	.021"	.032"	.043"	.050"	.062"	.072"	.080"	.093"	
4.440" round	—	—	No Fit: Combustion chambers extend beyond 4.440" round						
4.520" round	—	—	S355243L S355243R	S355250L S355250R	S355262L S355262R	S355272L S355272R	S355280L S355280R	S355293L S355293R	1
4.570" round	—	—	S355743L S355743R	S355750L S355750R	S355762L S355762R	S355772L S355772R	S355780L S355780R	S355793L S355793R	1
4.630" round	—	—	S356243L S356243R	S356250L S356250R	S356262L S356262R	S356272L S356272R	S356280L S356280R	S356293L S356293R	1

« Pro-Copper & Titan on previous page

**Ford Boss 429 · 429 ci · 7.0 L**

**Pro-Copper**

**Racing Head Gaskets**

For use with o-rings & sealant

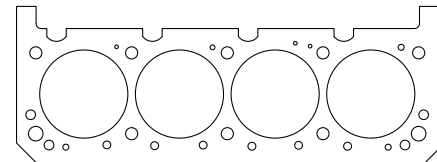

Bore Opening	Thickness								Qty.
	.021"	.032"	.043"	.050"	.062"	.072"	.080"	.093"	
4.380" round	P483821	P483832	P483843	P483850	P483862	P483872	P483880	P483893	1
4.440" round	P484421	P484432	P484443	P484450	P484462	P484472	P484480	P484493	1
4.520" round	P485221	P485232	P485243	P485250	P485262	P485272	P485280	P485293	1

**Racing Derivatives · Ford 460 Big Block C460 with 18-Bolt Heads**

**Pro-Copper  
Racing Head Gaskets**

For use with o-rings & sealant

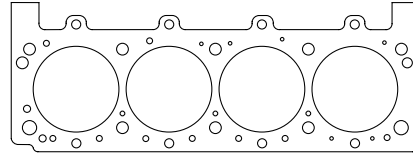

Bore Opening	Thickness								Qty.
	.021"	.032"	.043"	.050"	.062"	.072"	.080"	.093"	
4.520" round	-	P545232L P545232R	P545243L P545243R	P545250L P545250R	P545262L P545262R	P545272L P545272R	P545280L P545280R	P545293L P545293R	1
4.570" round	-	P545732L P545732R	P545743L P545743R	P545750L P545750R	P545762L P545762R	P545772L P545772R	P545780L P545780R	P545793L P545793R	1
4.630" round	-	P546232L P546232R	P546243L P546243R	P546250L P546250R	P546262L P546262R	P546272L P546272R	P546280L P546280R	P546293L P546293R	1

**Titan  
Copper Racing Head Gaskets**

Sealed coolant passages, for use with o-rings & sealant

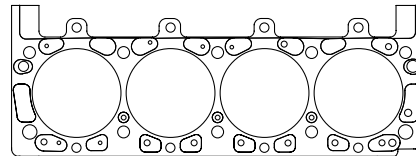

Bore Opening	Thickness								Qty.
	.021"	.032"	.043"	.050"	.062"	.072"	.080"	.093"	
4.520" round	-	T545232L T545232R	T545243L T545243R	T545250L T545250R	T545262L T545262R	T545272L T545272R	T545280L T545280R	T545293L T545293R	1
4.570" round	-	T545732L T545732R	T545743L T545743R	T545750L T545750R	T545762L T545762R	T545772L T545772R	T545780L T545780R	T545793L T545793R	1
4.630" round	-	P546232L P546232R	P546243L P546243R	P546250L P546250R	P546262L P546262R	P546272L P546272R	P546280L P546280R	P546293L P546293R	1

**ICS  
Copper Racing Head Gaskets**

Sealed coolant passages, integral combustion o-ring

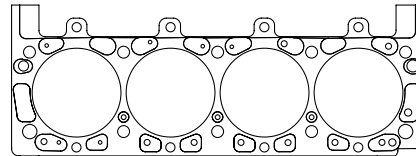

Bore Opening	Thickness								Qty.
	.021"	.032"	.043"	.050"	.062"	.072"	.080"	.093"	
4.520" round	-	-	<b>No Fit: Combustion chambers extend beyond 4.570" round</b>						
4.570" round	-	-							
4.630" round	-	-	S546243L S546243R	S546250L S546250R	S546262L S546262R	S546272L S546272R	S546280L S546280R	S546293L S546293R	1



**Racing Derivatives · Ford Racing Hemi, C&C Hemi**

**Pro-Copper  
Racing Head Gaskets**

For use with o-rings & sealant

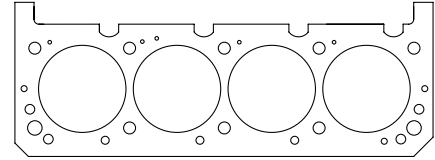

Bore Opening	Thickness								Qty.
	.021"	.032"	.043"	.050"	.062"	.072"	.080"	.093"	
4.520" round	—	P375232L P375232R	P375243L P375243R	P375250L P375250R	P375262L P375262R	P375272L P375272R	P375280L P375280R	P375293L P375293R	1
4.570" round	—	P375732L P375732R	P375743L P375743R	P375750L P375750R	P375762L P375762R	P375772L P375772R	P375780L P375780R	P375793L P375793R	1
4.630" round	—	P376232L P376232R	P376243L P376243R	P376250L P376250R	P376262L P376262R	P376272L P376272R	P376280L P376280R	P376293L P376293R	1

**Titan  
Copper Racing Head Gaskets**

Sealed coolant passages, for use with o-rings & sealant

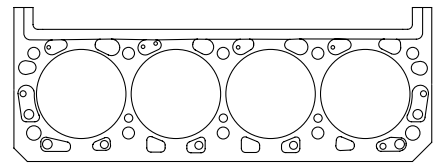

Bore Opening	Thickness								Qty.
	.021"	.032"	.043"	.050"	.062"	.072"	.080"	.093"	
4.520" round	—	T375232L T375232R	T375243L T375243R	T375250L T375250R	T375262L T375262R	T375272L T375272R	T375280L T375280R	T375293L T375293R	1
4.570" round	—	T375732L T375732R	T375743L T375743R	T375750L T375750R	T375762L T375762R	T375772L T375772R	T375780L T375780R	T375793L T375793R	1
4.630" round	—	T376232L T376232R	T376243L T376243R	T376250L T376250R	T376262L T376262R	T376272L T376272R	T376280L T376280R	T376293L T376293R	1

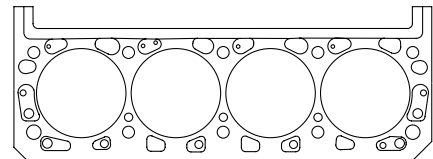

**ICS  
Copper Racing Head Gaskets**

Sealed coolant passages, integral combustion o-ring





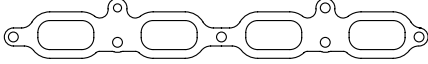
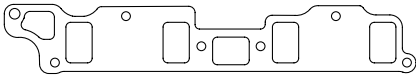
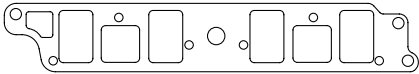

Bore Opening	Thickness								Qty.
	.021"	.032"	.043"	.050"	.062"	.072"	.080"	.093"	
4.520" round	—	—	S375243L S375243R	S375250L S375250R	S375262L S375262R	S375272L S375272R	S375280L S375280R	S375293L S375293R	1
4.570" round	—	—	S375743L S375743R	S375750L S375750R	S375762L S375762R	S375772L S375772R	S375780L S375780R	S375793L S375793R	1
4.630" round	—	—	S376243L S376243R	S376250L S376250R	S376262L S376262R	S376272L S376272R	S376280L S376280R	S376293L S376293R	1

## General Motors Inline 4 Cylinder · Intake Gaskets

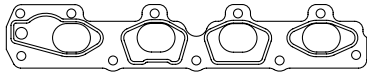
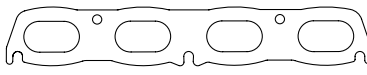
Application — Port Size	Thickness	Accu-Seal E Standard Material		Accu-Seal Pro · Premium Materials	
		Packaged 1 Pc.	Dyno-Pak · 10 Pcs.	Packaged 1 Pc.	Dyno-Pak · 10 Pcs.
<b>2000-07</b> <b>Ecotec DOHC · L4</b> <b>122-146 ci</b> <b>2.0-2.4 L</b> — <b>Stock Port</b>		† Silicone Bead Sealed Ports			
		.062"	922411	922411-10	922412 †
<b>1991-02</b> <b>Saturn · DOHC · L4</b> <b>116 ci · 1.9 L</b> — <b>Stock Port</b>		† Silicone Bead Sealed Ports			
		.062"	922611	922611-10	922612 †
<b>1988-02</b> <b>Oldsmobile</b> <b>Quad 4 · DOHC</b> <b>140 ci · 2.3 L</b> — <b>2.12" x 1.10"</b> <b>Oval</b>		† Silicone Bead Sealed Ports			
		.062"	—	—	280101
<b>1977-92</b> <b>Pontiac</b> <b>Cross-Flow L4</b> <b>151 ci · 2.5 L</b> — <b>1.11" x 1.72"</b> <b>Rectangle</b>		† Silicone Bead Sealed Ports			
		.062"	911611	911611-10	911612
<b>Pontiac</b> <b>Super Duty 4</b> <b>183 ci · 3.0 L</b> — <b>1.50" x 2.37"</b> <b>Rectangle</b>		† Silicone Bead Sealed Ports			
		.062"	911613	911613-10	911614

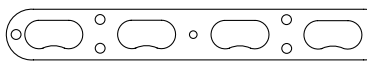
## General Motors Inline 4 Cylinder · Exhaust Gaskets

Application — Port Size	Accu-Seal E		<i>Accu-Seal Pro</i>		<i>Pro-Copper</i>	
	Standard Material .062"		Premium Material .062"		Embossed .043"	Flat-Annealed .062"
	Packaged 1 Pc.	Dyno-Pak 10 Pcs.	Packaged 1 Pc.	Dyno-Pak 10 Pcs.	Packaged 1 Pc.	Packaged 1 Pc.
<b>2000-07</b> <b>Ecotec · DOHC · L4</b> <b>122-146 ci</b> <b>2.0-2.4 L</b> — <b>Stock Port · Oval</b>			Embossed copper gasket fits factory iron manifold or machined flat header flange			
	924481	924481-10	924482	924482-10	9431	—
<b>1991-98</b> <b>LKO</b> <b>Saturn · SOHC · L4</b> <b>116 ci · 1.9 L</b> — <b>Stock Port · Oval</b>						
	922680	922680-10	—	—	—	—
<b>1999-02</b> <b>LLO</b> <b>Saturn · DOHC · L4</b> <b>116 ci · 1.9 L</b> — <b>Stock Port · Oval</b>			Composite gasket set includes EGR & 3-bolt collector gaskets			
	922681	922681-10	922682	922682-10	9446	—
<b>1988-02</b> <b>Oldsmobile</b> <b>Quad 4 · DOHC</b> <b>140 ci · 2.3 L</b> — <b>2.45" x 1.20"</b> <b>Oval</b>						
	—	—	280180	280180-10	—	—
<b>1977-92</b> <b>Pontiac</b> <b>Cross-Flow · L4</b> <b>151 ci · 2.5 L</b> — <b>Irregular</b>			Early round-port. OEM-style steel-back material.			
	911681	911681-10	911682	911682-10	—	—
			Late rectangular-port. OEM-style steel-back material.			
	911683	911683-10	911684	911684-10	—	—

## General Motors Inline 4 Cylinder · Accu-Seal Pro · Performance Head Gaskets

Application	Image	Bore Opening	Compr. Thick.	Part Number	Description	Qty.
1988-02 Oldsmobile Quad 4 DOHC 140 ci 2.3 L		3.690"	.043"	5806943	Graphite and steel construction.	1

### General Motors Inline 4 Cylinder · Ecotec DOHC · 2.0-2.4L · 122-146 ci

#### **Pro-Copper** **Racing Head Gaskets**

For use with o-rings & sealant

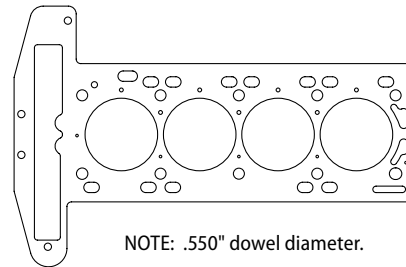

Bore Opening	Thickness								Qty.
	.021"	.032"	.043"	.050"	.062"	.072"	.080"	.093"	
3.500" round	P922521	P922532	P922543	P922550	P922562	P922572	P922580	P922593	1

#### **Titan** **Copper Racing Head Gaskets**

Sealed coolant passages, for use with o-rings & sealant

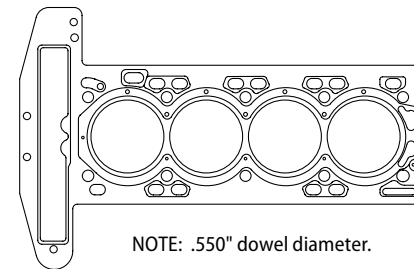

Bore Opening	Thickness								Qty.
	.021"	.032"	.043"	.050"	.062"	.072"	.080"	.093"	
3.500" round	—	T922532	T922543	T922550	T922562	T922572	T922580	T922593	1

#### **ICS** **Copper Racing Head Gaskets**

Sealed coolant passages, integral combustion o-ring

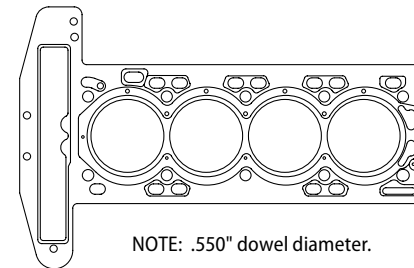

Bore Opening	Thickness								Qty.
	.021"	.032"	.043"	.050"	.062"	.072"	.080"	.093"	
3.500" round	—	—	S922543	S922550	S922562	S922572	S922580	S922593	1

**General Motors Inline 4 Cylinder • Saturn 1.9 L SOHC • 116 ci**

**Pro-Copper  
Racing Head Gaskets**

For use with o-rings & sealant

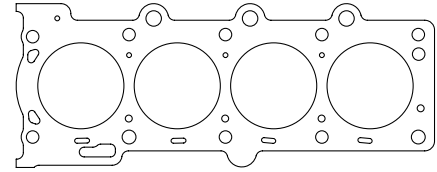

Bore Opening	Thickness								Qty.
	.021"	.032"	.043"	.050"	.062"	.072"	.080"	.093"	
3.305" round	P925921	P925932	P925943	P925950	P925962	P925972	P925980	P925993	1

**General Motors Inline 4 Cylinder • Saturn 1.9 L DOHC • 116 ci**

**Pro-Copper  
Racing Head Gaskets**

For use with o-rings & sealant

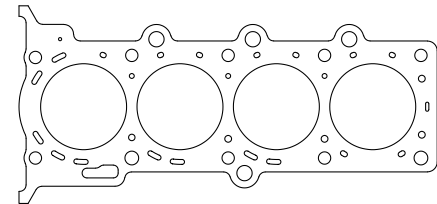

Bore Opening	Thickness								Qty.
	.021"	.032"	.043"	.050"	.062"	.072"	.080"	.093"	
3.305" round	P922621	P922632	P922643	P922650	P922662	P922672	P922680	P922693	1

**Titan  
Copper Racing Head Gaskets**

Sealed coolant passages, for use with o-rings & sealant

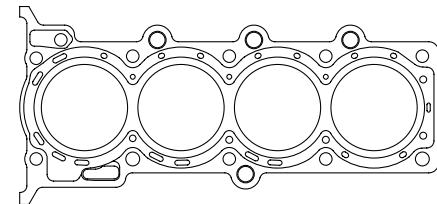

Bore Opening	Thickness								Qty.
	.021"	.032"	.043"	.050"	.062"	.072"	.080"	.093"	
3.305" round	–	T922632	T922643	T922650	T922662	T922672	T922680	T922693	1

**ICS  
Copper Racing Head Gaskets**

Sealed coolant passages, integral combustion o-ring

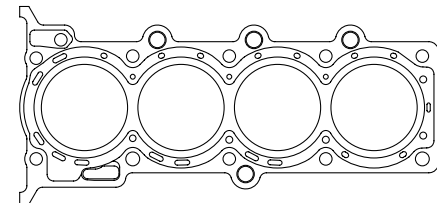

Bore Opening	Thickness								Qty.
	.021"	.032"	.043"	.050"	.062"	.072"	.080"	.093"	
3.305" round	–	–	S922643	S922650	S922662	S922672	S922680	S922693	1

**General Motors Inline 4 Cylinder • Quad-4 DOHC • 2.3-2.4 L • 140-146 ci**

**Pro-Copper  
Racing Head Gaskets**

For use with o-rings & sealant

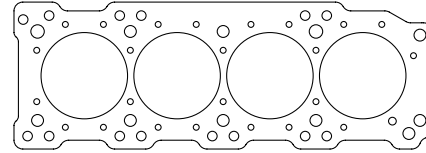

Bore Opening	Thickness								Qty.
	.021"	.032"	.043"	.050"	.062"	.072"	.080"	.093"	
3.625" round	P917021	P917032	P917043	P917050	P917062	P917072	P917080	P917093	1

**Titan  
Copper Racing Head Gaskets**

Sealed coolant passages, for use with o-rings & sealant

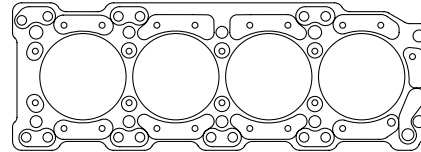

Bore Opening	Thickness								Qty.
	.021"	.032"	.043"	.050"	.062"	.072"	.080"	.093"	
3.625" round	–	T917032	T917043	T917050	T917062	T917072	T917080	T917093	1

**ICS  
Copper Racing Head Gaskets**

Sealed coolant passages, integral combustion o-ring

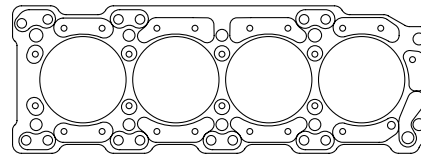

Bore Opening	Thickness								Qty.
	.021"	.032"	.043"	.050"	.062"	.072"	.080"	.093"	
3.625" round	–	–	S917043	S917050	S917062	S917072	S917080	S917093	1

**GM Inline 4 Cylinder • Pontiac Cross-Flow, Super Duty 4 • 2.5 L • 151 ci**

**Pro-Copper  
Racing Head Gaskets**

For use with o-rings & sealant

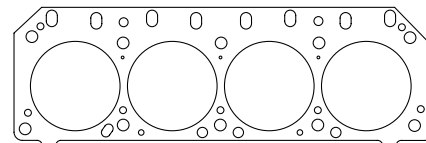

Bore Opening	Thickness								Qty.
	.021"	.032"	.043"	.050"	.062"	.072"	.080"	.093"	
4.060" round	P911621	P911632	P911643	P911650	P911662	P911672	P911680	P911693	1

## Honda · Intake Gaskets

Application — Port Size	Thickness	Accu-Seal E Standard Material		Accu-Seal Pro · Premium Materials	
		Packaged 1 Pc.	Dyno-Pak · 10 Pcs.	Packaged 1 Pc.	Dyno-Pak · 10 Pcs.
<b>1992-00</b> <b>D16 · 1.6 L · L4</b> <b>Civic, Del Sol, SI</b> <b>98 ci</b> — <b>1.87" x 1.35" Oval</b>	1.6 mm .062"	913611	913611-10	913612	913612-10
<b>1993-01</b> <b>B16/18 · 1.6/1.8 L</b> <b>L4 · Civic, Del Sol, SI</b> <b>98 / 110 ci</b> — <b>1.87" x 1.37" Oval</b>	1.6 mm .062"	913811	913811-10	913812	913812-10
<b>1999-09</b> <b>F20C/22C · 2.2 L</b> <b>L4 · S 2000</b> <b>134 ci</b> — <b>1.75" x 1.44" Oval</b>	1.6 mm .062"	923111	923111-10	923112	923112-10
<b>1993-01</b> <b>H22A/23 · 2.2-2.3 L</b> <b>L4 · Prelude, SI, SE</b> <b>134-140 ci</b> — <b>1.90" x 1.31" Oval</b>	1.6 mm .062"	914011	914011-10	914012	914012-10

## Honda · Exhaust Gaskets

Application — Port Size	Accu-Seal E		Accu-Seal Pro		Pro-Copper	
	Standard Material 1.6 mm / .062"		Premium Material 1.6 mm / .062"		Embossed 1.1 mm / .043"	Flat-Annealed 1.6 mm / .062"
	Packaged 1 Pc.	Dyno-Pak 10 Sets	Packaged 1 Pc.	Dyno-Pak 10 Pcs.	Packaged 1 Pc.	Packaged 1 Pc.
<b>1986-Up</b> <b>D16 · 1.6 L · L4</b> <b>Civic, Del Sol, SI</b> <b>98 ci</b> — <b>1.87" x 1.37" Oval</b>						
	913681	913681-10	913682	913682-10	9401	—
<b>1993-01</b> <b>B16/18 · 1.6/1.8 L</b> <b>L4 · Civic, Del</b> <b>Sol, SI</b> <b>98 / 110 ci</b> — <b>1.87" x 1.37" Oval</b>						
	913881	913881-10	913882	913882-10	9404	—
<b>1993-01</b> <b>H22A/23</b> <b>2.2-2.3 L · L4</b> <b>Prelude, SI, SE</b> <b>134-140 ci</b> — <b>1.99" x 1.62" Oval</b>						
	914081	914081-10	914082	914082-10	9430	—
<b>1994-97</b> <b>F22B · 2.2 L</b> <b>L4 · Accord</b> <b>134 ci</b> — <b>1.87" x 1.37" Oval</b>						
	921781	921781-10	921782	921782-10	9403	—
<b>1999-09</b> <b>F20C/22C</b> <b>2.0-2.2 L · L4</b> <b>S 2000</b> <b>134 ci</b> — <b>1.75" x 1.44" Oval</b>						
	923181	923181-10	923182	923182-10	9467	—
<b>1992-96</b> <b>H23A · 2.3 L · L4</b> <b>Prelude, SI, SE</b> <b>140 ci</b> — <b>1.90" x 1.31" Oval</b>						
	914181	914181-10	914182	914182-10	9402	—



## Honda · *MLS Spartan Performance Head Gaskets*

Application	Image	Bore Opening	Compr. Thick.	Part Number	Description	Qty.
<b>1987-95</b> <b>D13B1-B2 /</b> <b>D15B1-B8</b> <b>D16A6-A7</b> <b>D16Z1-Z2</b> <b>L4</b> <b>1.3-1.6 L</b> <b>79-98 ci</b>		76.0 mm 2.992"	0.85 mm .033"	M338107GS	MLS Spartan with <b>Gas-Stopper</b> embossed stainless steel construction.	1
		77.0 mm 3.031"		M338108GS		1
		78.0 mm 3.070"		M338109	MLS embossed stainless steel construction.	1
		79.0 mm 3.110"		M338110GS		1
<b>1991-00</b> <b>D15Z1</b> <b>L4</b> <b>1.5 L</b> <b>92 ci</b>		76.0 mm 2.993"	0.85 mm .033"	M338112GS	MLS Spartan with <b>Gas-Stopper</b> embossed stainless steel construction.	1
		77.0 mm 3.032"		M338113GS		1
		78.0 mm 3.071"		M338114GS		1
<b>1991-00</b> <b>D16Y5 / Y8 · L4</b> <b>1.6 L</b> <b>98 ci</b>		81.0 mm 3.189"	0.85 mm .033"	M338098GS	MLS Spartan with <b>Gas-Stopper</b> embossed stainless steel construction.	1
<b>1990-93</b> <b>D16A / B18C</b> <b>L4</b> <b>1.6-1.8 L</b> <b>98-110 ci</b>		82.0 mm 3.228"		M338100GS		1
		83.0 mm 3.268"		M338101GS		1
		84.0 mm 3.308"		M338102GS		1
		85.0 mm 3.347"		M338103GS		1
<b>1999-00</b> <b>B16A2-3 / B17A1 /</b> <b>B18C1-C5</b> <b>L4</b> <b>1.6-1.8 L</b> <b>98-110 ci</b>		81.5 mm 3.209"	0.85 mm .033"	M338085GS	MLS Spartan with <b>Gas-Stopper</b> embossed stainless steel construction.	1
		82 mm 3.229"		M338086GS		1
		83 mm 3.268"		M338087GS		1
		84.0 mm 3.308"		M338088GS		1
		85.0 mm 3.347"		M338089GS		1

**Marine Use:** stainless steel construction, all MLS Spartan head gaskets are suitable for use in marine applications.

*MLS Spartan continued on next page »*

## Honda · *MLS Spartan* Performance Head Gaskets

Application	Image	Bore Opening	Compr. Thick.	Part Number	Description	Qty.
<b>1986-00</b> <b>B18A / B18B</b> <b>DOHC</b> <b>L4</b> <b>1.8 L</b> <b>92 ci</b>		81.0 mm 3.189"	0.9 mm .034"	M338090GS	MLS Spartan with <b>Gas-Stopper</b> embossed stainless steel construction.	1
		82.0 mm 3.228"		M338092GS		1
		83.0 mm 3.267"		M338093GS		1
		84.0 mm 3.307"		M338094GS		1
		85.0 mm 3.346"	0.75 mm .029"	M338096	1	
<b>1999-00</b> <b>B18C</b> <b>L4</b> <b>1.8 L</b> <b>110 ci</b>		81.5 mm 3.209"	0.6 mm .024"	M338402	MLS embossed stainless steel construction.	1
<b>1997-01</b> <b>B20B-B20B4 /</b> <b>B20Z1-2</b> <b>L4</b> <b>2.0 L</b> <b>122 ci</b>		85.0 mm 3.347"	0.9 mm .034"	M338104GS	MLS Spartan with <b>Gas-Stopper</b> embossed stainless steel construction.	1
<b>2000-Up</b> <b>F20C1-C2 / F22C1</b> <b>DOHC VTEC</b> <b>L4</b> <b>2.0 L</b> <b>122 ci</b>		89.0 mm 3.504"	0.9 mm .034"	M338124GS		1
<b>2001-Up</b> <b>K20A1-2-3 / K24A</b> <b>L4</b> <b>2.0-2.3 L</b> <b>122-140 ci</b>		87.0 mm 3.426"	0.8 mm .032"	M338430GS		1
		88.5 mm 3.485"	0.9 mm .034"	M338411GS	1	
		89.5 mm 3.524"		M338468GS	1	
<p><b>Marine Use:</b> stainless steel construction, all MLS Spartan head gaskets are suitable for use in marine applications.</p>						

« *MLS Spartan* continued from previous page

**Honda D16 SOHC · 1.6 L · 98 ci**

**Pro-Copper  
Racing Head Gaskets**

For use with o-rings & sealant

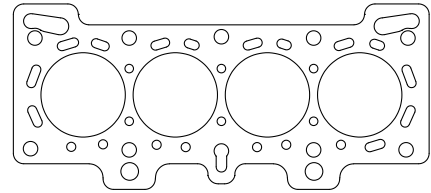

Bore Opening	Thickness								Qty.
	.021"	.032"	.043"	.050"	.062"	.072"	.080"	.093"	
76.2 mm round 3.00"	P913621	P913632	P913643	P913650	P913662	P913672	P913680	P913693	1

**Titan  
Copper Racing Head Gaskets**

Sealed coolant passages, for use with o-rings & sealant

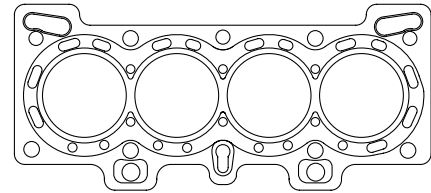

Bore Opening	Thickness								Qty.
	.021"	.032"	.043"	.050"	.062"	.072"	.080"	.093"	
76.2 mm round 3.00"	—	T913632	T913643	T913650	T913662	T913672	T913680	T913693	1

**Honda B Series DOHC VTEC · 1.8 L · 110 ci**

**Pro-Copper  
Racing Head Gaskets**

For use with o-rings & sealant

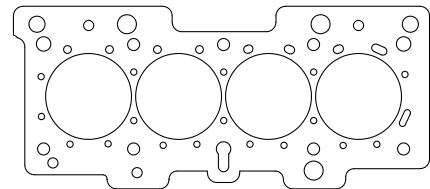

Bore Opening	Thickness								Qty.
	.021"	.032"	.043"	.050"	.062"	.072"	.080"	.093"	
82.5 mm round 3.250"	P913821	P913832	P913843	P913850	P913862	P913872	P913880	P913893	1

**Titan  
Copper Racing Head Gaskets**

Sealed coolant passages, for use with o-rings & sealant

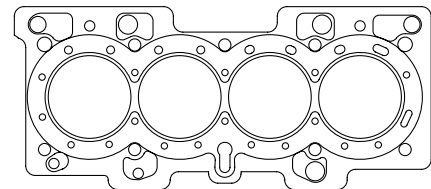

Bore Opening	Thickness								Qty.
	.021"	.032"	.043"	.050"	.062"	.072"	.080"	.093"	
82.5 mm round 3.250"	—	T913832	T913843	T913850	T913862	T913872	T913880	T913893	1

ICS on next page »

**Honda B Series DOHC VTEC • 1.8 L • 110 ci**

**ICS**  
**Copper Racing Head Gaskets**

Sealed coolant passages, integral combustion o-ring

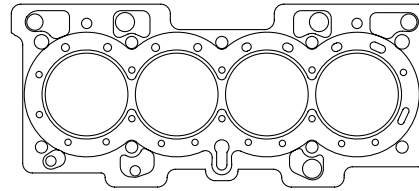

Bore Opening	Thickness								Qty.
	.021"	.032"	.043"	.050"	.062"	.072"	.080"	.093"	
82.5 mm round 3.250"	—	—	S913843	S913850	S913862	S913872	S913880	S913893	1

« Pro-Copper & Titan on previous page

**Honda F22A • 2.2 L • 134 ci • SOHC Non-VTEC**

**Pro-Copper**  
**Racing Head Gaskets**

For use with o-rings & sealant

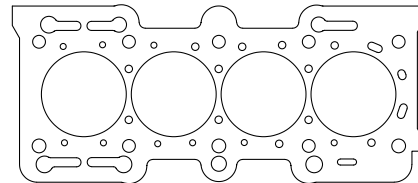

Bore Opening	Thickness								Qty.
	.021"	.032"	.043"	.050"	.062"	.072"	.080"	.093"	
87.3 mm round 3.437"	P921721	P921732	P921743	P921750	P921762	P921772	P921780	P921793	1

**Titan**  
**Copper Racing Head Gaskets**

Sealed coolant passages, for use with o-rings & sealant

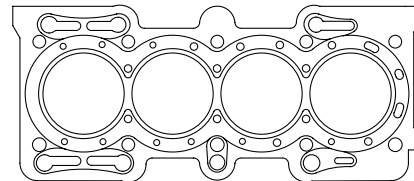

Bore Opening	Thickness								Qty.
	.021"	.032"	.043"	.050"	.062"	.072"	.080"	.093"	
87.3 mm round 3.437"	—	T921732	T921743	T921750	T921762	T921772	T921780	T921793	1

**ICS**  
**Copper Racing Head Gaskets**

Sealed coolant passages, integral combustion o-ring

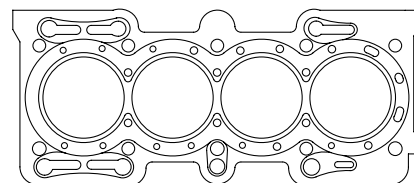

Bore Opening	Thickness								Qty.
	.021"	.032"	.043"	.050"	.062"	.072"	.080"	.093"	
87.3 mm round 3.437"	—	—	S921743	S921750	S921762	S921772	S921780	S921793	1

**Honda H22A DOHC · 2.2 L · 134 ci**

**Pro-Copper  
Racing Head Gaskets**

For use with o-rings & sealant

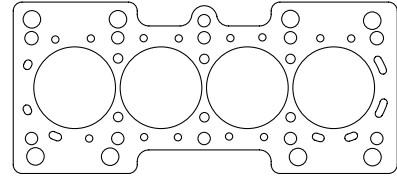

Bore Opening	Thickness								Qty.
	.021"	.032"	.043"	.050"	.062"	.072"	.080"	.093"	
88.9 mm round 3.500"	P914021	P914032	P914043	P914050	P914062	P914072	P914080	P914093	1

**Titan  
Copper Racing Head Gaskets**

Sealed coolant passages, for use with o-rings & sealant

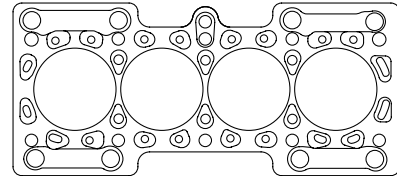

Bore Opening	Thickness								Qty.
	.021"	.032"	.043"	.050"	.062"	.072"	.080"	.093"	
88.9 mm round 3.500"	—	T914032	T914043	T914050	T914062	T914072	T914080	T914093	1

**ICS  
Copper Racing Head Gaskets**

Sealed coolant passages, integral combustion o-ring

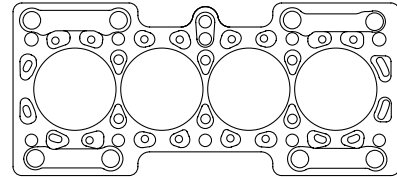

Bore Opening	Thickness								Qty.
	.021"	.032"	.043"	.050"	.062"	.072"	.080"	.093"	
88.9 mm round 3.500"	—	—	S914043	S914050	S914062	S914072	S914080	S914093	1

**Honda H23A DOHC · 2.3 L · 140 ci**

**Pro-Copper  
Racing Head Gaskets**

For use with o-rings & sealant

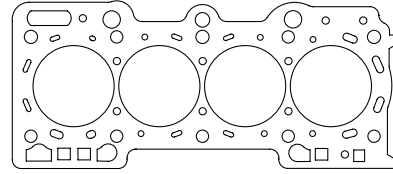

Bore Opening	Thickness								Qty.
	.021"	.032"	.043"	.050"	.062"	.072"	.080"	.093"	
88.9 mm round 3.500"	P914121	P914132	P914143	P914150	P914162	P914172	P914180	P914193	1

**Honda F20C-F22C1 · 2.0 L-2.2 L · 122 ci-134 ci · DOHC L4**

**Pro-Copper  
Racing Head Gaskets**

For use with o-rings & sealant

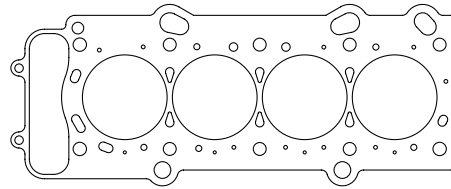

Bore Opening	Thickness								Qty.
	.021"	.032"	.043"	.050"	.062"	.072"	.080"	.093"	
88.9 mm round 3.500"	P923121	P923132	P923143	P923150	P923162	P923172	P923180	P923193	1

### Mitsubishi · Intake Gaskets

Application — Port Size	Thickness	Accu-Seal E Standard Material		Accu-Seal Pro · Premium Materials	
		Packaged 1 Pc.	Dyno-Pak · 10 Pcs.	Packaged 1 Pc.	Dyno-Pak · 10 Pcs.
<b>1989-94</b> <b>4G63 · L4</b> <b>with 6-Bolt flywheel</b> <b>2.0 L · 122 ci</b> — <b>2.40" x 1.47"</b> <b>Rectangle</b>					
	1.6 mm .062"	915211	915211-10	915212	915212-10
<b>1996-05</b> <b>4G63 Evo · L4</b> <b>2.0 L · 122 ci</b> — <b>2.45" x 1.52"</b> <b>Rectangle</b>					
	1.6 mm .062"	926711	926711-10	926712	926712-10

### Mitsubishi · Exhaust Gaskets

Application — Port Size	Accu-Seal E		Accu-Seal Pro		Pro-Copper		
	Standard Material 1.6 mm / .062"		Premium Material 1.6 mm / .062"		Embossed 1.1 mm / .043"	Flat-Annealed 1.6 mm / .062"	
	Packaged 1 Pc.	Dyno-Pak 10 Pcs.	Packaged 1 Pc.	Dyno-Pak 10 Pcs.	Packaged 1 Pc.	Packaged 1 Pc.	
<b>1989-Up</b> <b>4G63 · L4</b> <b>2.0 L · 122 ci</b> <b>Manifold-to-Head</b> — <b>2.11" x 1.25" Oval</b>						Seals factory iron manifold or machined flat header flange. Fits all including 7-bolt EVO.	
	—	—	—	—	9405	—	
<b>4G63T · L4</b> <b>Turbine Housing to Manifold</b> <b>2.0 L · 122 ci</b> — <b>2.385" Round</b>							
	—	—	—	—	9449	—	
<b>1983-2015</b> <b>2.4 L</b> <b>143 ci</b> <b>4G64 · L4</b> <b>Manifold to Head</b> — <b>1.65" Round</b>							
	—	—	—	—	9448	—	

**Mitsubishi · MLS Spartan · Performance Head Gaskets**

Application	Image	Bore Opening	Compr. Thick.	Part Number	Description	Qty.
1989-94 4G63 Evo 1-3 DOHC · L4 6-bolt 2.0 L · 121 ci		86.5 mm 3.406"	1.2 mm .049"	M338494GS	MLS Spartan with <b>Gas-Stopper</b> embossed stainless steel construction.	1
1996-05 4G63 Evo 4-9 DOHC · L4 7-bolt 2.0 L 122 ci		85.3 mm 3.359"	1.0 mm .039"	M338024GS		1
			1.15 mm .045"	M338020GS		1
			1.3 mm .051"	M338016GS		1
		86.3 mm 3.398"	1.0 mm .039"	M338025GS		1
			1.15 mm .045"	M338021GS		1
			1.3 mm .051"	M338017GS		1
			1.0 mm .038"	M338421GS		1
		87.3 mm 3.438"	1.0 mm .039"	M338026GS		1
			1.3 mm .051"	M338018GS		1
		87.5 mm 3.445"	1.15 mm .045"	M338022GS		1
		88.3 mm 3.477"	1.0 mm .039"	M338027GS		1
		88.3 mm 3.477"	1.15 mm .045"	M338023GS		1
			1.3 mm .051"	M338019GS		1
		2007-Up 4B11T Evo X DOHC · L4 2.0 L 122 ci		87.5 mm 3.445"		1.0 mm .039"

**Marine Use:** stainless steel construction, all MLS Spartan head gaskets are suitable for use in marine applications.



**Mitsubishi · Vulcan Cut-Ring · Performance Head Gaskets**

Application	Image	Bore Opening	Compr. Thick.	Part Number	Description	Qty.
1992-95 4G63 DOHC Evo 1-3 L4 2.0 L 121 ci		86.5 mm 3.406"	1.3 mm .051"	CR330058	Stainless steel Cut-Ring combustion seals (not pictured).  Composite gasket body construction.	1
1996-05 4G63 Evo 4-9 DOHC L4 2.0 L 122 ci		87.5 mm 3.445"	1.2 mm .047"	CR330042		1
		86.3 mm 3.398"	1.3 mm .051"	CR330038		1
2007-Up 4B11T Evo X DOHC L4 2.0 L 122 ci		89.0mm 3.504"	1.2 mm .047"	CR330127		1
2000-05 6G72 DOHC/ SOHC V6 3.0 L 181 ci		93.5 mm 3.682"	1.2 mm .047"	CR330071		1
		95.0 mm 3.740"		CR330098	1	

**Mitsubishi · 4G63/T Evo 1-3 · 6-bolt · DOHC · 2.0 L · 122 ci**

**Pro-Copper  
Racing Head Gaskets**

For use with o-rings & sealant

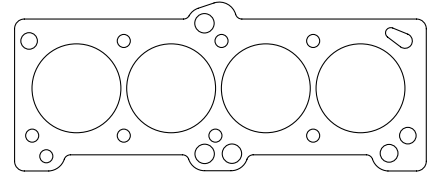
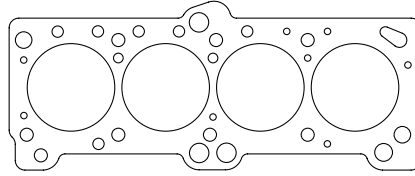

No water holes: use suffix "NW"

Bore Opening	Thickness								Qty.
	.021"	.032"	.043"	.050"	.062"	.072"	.080"	.093"	
85.7 mm round 3.375"	P915221	P915232	P915243	P915250	P915262	P915272	P915280	P915293	1
87.3 mm round 3.437"	P927521	P927532	P927543	P927550	P927562	P927572	P927580	P927593	1

**Titan  
Copper Racing Head Gaskets**

Sealed coolant passages, for use with o-rings & sealant

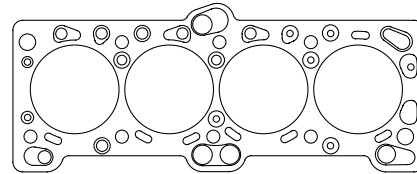

Bore Opening	Thickness								Qty.
	.021"	.032"	.043"	.050"	.062"	.072"	.080"	.093"	
85.7 mm round 3.375"	—	T915232	T915243	T915250	T915262	T915272	T915280	T915293	1

**ICS  
Copper Racing Head Gaskets**

Sealed coolant passages, integral combustion o-ring

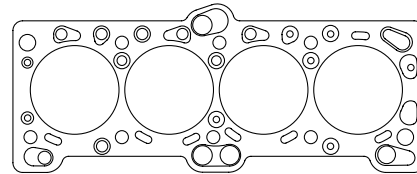

Bore Opening	Thickness								Qty.
	.021"	.032"	.043"	.050"	.062"	.072"	.080"	.093"	
85.7 mm round 3.375"	—	—	S915243	S915250	S915262	S915272	S915280	S915293	1

**Mitsubishi · 4G64 SOHC · 2.4 L · 146 ci**

**Pro-Copper  
Racing Head Gaskets**

For use with o-rings & sealant

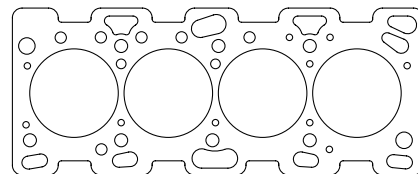

Bore Opening	Thickness								Qty.
	.021"	.032"	.043"	.050"	.062"	.072"	.080"	.093"	
87.3 mm round 3.437"	P923421	P923432	P923443	P923450	P923462	P923472	P923480	P923493	1

**Mitsubishi · 4G63 Evo 4-9 · 7-bolt · 2.0 L · 122 ci**

**Pro-Copper  
Racing Head Gaskets**

For use with o-rings & sealant

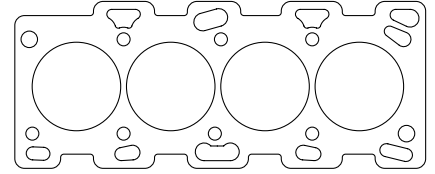
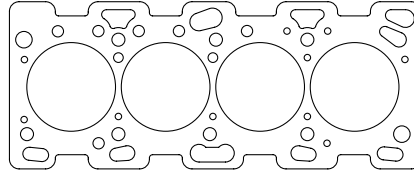

No water holes: use suffix "NW"

Bore Opening	Thickness								Qty.
	.021"	.032"	.043"	.050"	.062"	.072"	.080"	.093"	
87.3 mm round 3.437"	P926721	P926732	P926743	P926750	P926762	P926772	P926780	P926793	1

**Titan  
Copper Racing Head Gaskets**

Sealed coolant passages, for use with o-rings & sealant

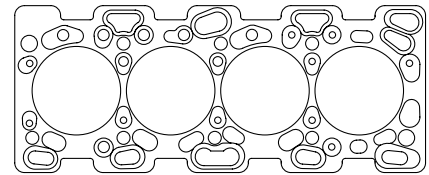

Bore Opening	Thickness								Qty.
	.021"	.032"	.043"	.050"	.062"	.072"	.080"	.093"	
87.3 mm round 3.437"	—	T926732	T926743	T926750	T926762	T926772	T926780	T926793	1

**ICS  
Copper Racing Head Gaskets**

Sealed coolant passages, integral combustion o-ring

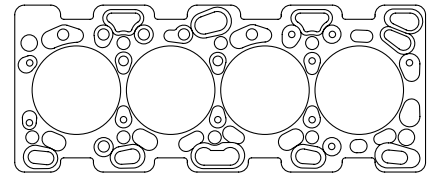

Bore Opening	Thickness								Qty.
	.021"	.032"	.043"	.050"	.062"	.072"	.080"	.093"	
87.3 mm round 3.437"	—	—	S926743	S926750	S926762	S926772	S926780	S926793	1

**Mitsubishi · 4G54 SOHC · 2.6 L · 159 ci**

**Pro-Copper  
Racing Head Gaskets**

For use with o-rings & sealant

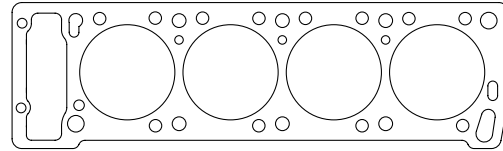

Bore Opening	Thickness								Qty.
	.021"	.032"	.043"	.050"	.062"	.072"	.080"	.093"	
93.2 mm round 3.670"	P915321	P915332	P915343	P915350	P915362	P915372	P915380	P915393	1

**Titan  
Copper Racing Head Gaskets**

Sealed coolant passages, for use with o-rings & sealant

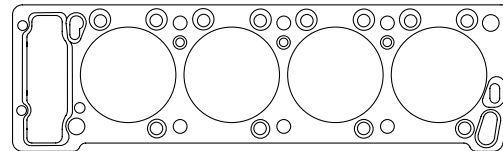

Bore Opening	Thickness								Qty.
	.021"	.032"	.043"	.050"	.062"	.072"	.080"	.093"	
93.2 mm round 3.670"	–	T915332	T915343	T915350	T915362	T915372	T915380	T915393	1

**ICS  
Copper Racing Head Gaskets**

Sealed coolant passages, integral combustion o-ring

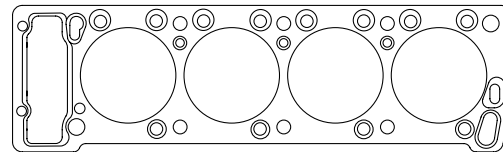

Bore Opening	Thickness								Qty.
	.021"	.032"	.043"	.050"	.062"	.072"	.080"	.093"	
93.2 mm round 3.670"	–	–	S915343	S915350	S915362	S915372	S915380	S915393	1

**Mitsubishi V6 · 6G72 DOHC · 3.0 L · 183 ci**

**Pro-Copper  
Racing Head Gaskets**

For use with o-rings & sealant

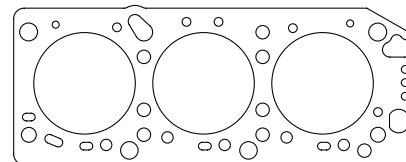

Bore Opening	Thickness								Qty.
	.021"	.032"	.043"	.050"	.062"	.072"	.080"	.093"	
93.2 mm round 3.670"	P917321	P917332	P917343	P917350	P917362	P917372	P917380	P917393	1

## Nissan · Exhaust Gaskets

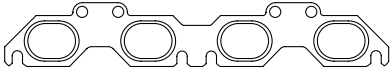
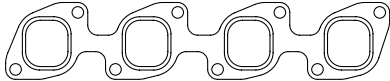
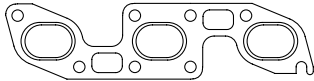
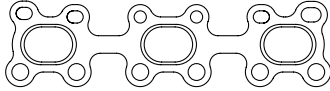
Application — Port Size	Accu-Seal E		Accu-Seal Pro		Pro-Copper	
	Standard Material 1.6 mm / .062"		Premium Material 1.6 mm / .062"		Embossed 1.1 mm / .043"	Flat-Annealed 1.6 mm / .062"
	Packaged 1 Set	Dyno-Pak 10 Sets	Packaged 1 Set	Dyno-Pak 10 Sets	Packaged 1 Set	Packaged 1 Set
<b>1991-02</b> <b>SR20DE / DET</b> <b>DOHC · L4</b> <b>2.0 L · 122 ci</b> — <b>1.87" X 1.37"</b> <b>Oval</b>			Set contains 1 pc.			
<b>1993-04</b> <b>KA24DE</b> <b>DOHC · L4</b> <b>2.4 L · 146 ci</b> — <b>1.60" X 1.75"</b> <b>Square</b>			Set contains 1 pc.			
<b>1990-99</b> <b>VG30DETT · V6</b> <b>3.0 L · 181 ci</b> — <b>1.80" X 1.25"</b> <b>Oval</b>						
<b>2001-13</b> <b>VQ35DE</b> <b>DOHC · V6</b> <b>3.5 L · 214 ci</b> — <b>1.72" X 1.25"</b> <b>Oval</b>						

**Nissan · MLS Spartan · Performance Head Gaskets**

Application	Image	Bore Opening	Compr. Thick.	Part Number	Description	Qty.
1983-93 CA18DE / DET L4 1.8 L · 110 ci		85.0 mm 3.347"	1.3 mm .051"	M338135GS	MLS Spartan with <b>Gas-Stopper</b> embossed stainless steel construction.	1
1989-2007 SR20DE L4 2.0 L · 122 ci  No extra oil holes		88.5 mm 3.485"	0.85 mm .033"	M338150GS		1
1997-2007 SR20VE-VET L4 2.0 L · 122 ci  1 extra oil hole		87.5 mm 3.445"	1.0 mm .039"	M338152GS		1
1989-2007 SR20DE, VE, VET, DET L4 2.0 L · 122 ci  2 extra oil holes		87.0 mm 3.426"	1.5 mm .059"	M338415GS		1
		88.5 mm 3.485"	1.0 mm .039"	M338151GS		
1989-93 RB25 Skyline L6 2.5 L 152 ci		87.0 mm 3.426"	1.3 mm .051"	M338144GS		1
			1.5 mm .059"	M338414GS		1
1989-02 RB26 Skyline GT-R L6 2.6 L 158 ci		87.5 mm 3.445"	1.2 mm .047"	M338146GS		1
		87.5 mm 3.445"	1.5 mm .059"	M338315GS	1	
<p><b>Marine Use:</b> stainless steel construction, all MLS Spartan head gaskets are suitable for use in marine applications.</p>						

**Nissan · MLS Spartan · Performance Head Gaskets**

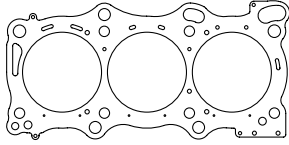
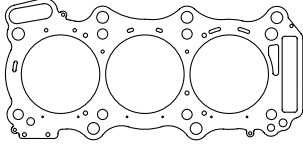
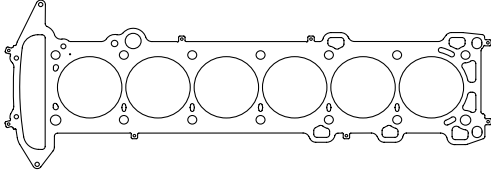
Application	Image	Bore Opening	Compr. Thick.	Part Number	Description	Qty.
<b>2008 VR38DETT GT-R · V6 3.8 L 231 ci</b>		100.5 mm 3.957"	0.95 mm .037"	M338406GS <i>Right</i>	MLS Spartan with <b>Gas-Stopper</b> embossed stainless steel construction.	1
		100.5 mm 3.957"	0.95 mm .037"	M338407GS <i>Left</i>		1
<b>2000-Up TB48DE Patrol L6 4.8 L 291 ci</b>		100.5 mm 3.957"	0.8 mm .032"	M338435GS		1
		100.5 mm 3.957"	1.6 mm .063"	M338436GS		1
		100.5 mm 3.957"	1.95 mm .077"	M338437GS		1
		101.7 mm 4.004"	1.6 mm .063"	M338438GS		1
		101.7 mm 4.004"	1.95 mm .077"	M338439GS	1	
		102.5 mm 4.036"	1.2 mm .047"	M338426	MLS embossed stainless steel construction.	1
<p><b>Marine Use:</b> stainless steel construction, all MLS Spartan head gaskets are suitable for use in marine applications.</p>						

**Nissan · Vulcan Cut-Ring · Performance Head Gaskets**

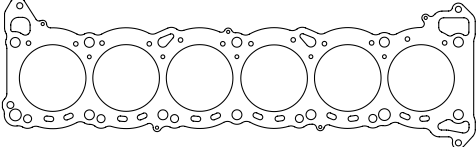
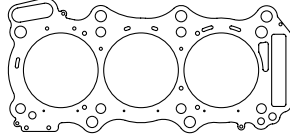
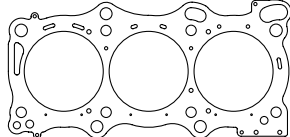
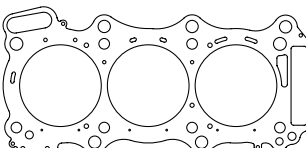
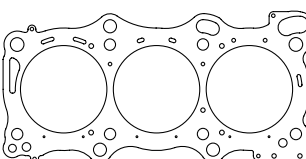
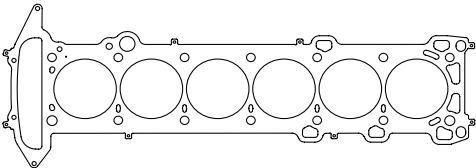
Application	Image	Bore Opening	Compr. Thick.	Part Number	Description	Qty.
<b>1989-02</b> <b>RB26</b> <b>Skyline GT-R</b> <b>L6</b> <b>2.6 L</b> <b>158 ci</b>		87.5 mm 3.445"	1.5 mm .059"	CR330089		1
		88.0 mm 3.464"	1.2 mm .047"	CR330134		1
			1.5 mm .059"	CR330133		1
<b>2008</b> <b>VR38DETT</b> <b>GT-R</b> <b>V6</b> <b>3.8 L</b> <b>231 ci</b>		96.5 mm 3.800"	1.0 mm .039"	CR330087L <i>Left</i>	Stainless steel Cut-Ring combustion seals (not pictured).  Composite gasket body construction.	1
				CR330088R <i>Right</i>		1
		100.5 mm 3.957"		CR330067L <i>Left</i>		1
				CR330068R <i>Right</i>		1
<b>2000-Up</b> <b>TB48DE</b> <b>Patrol</b> <b>L6</b> <b>4.8 L</b> <b>291 ci</b>		101.0 mm 3.976"	1.2 mm .047"	CR330090	1	
			1.6 mm .062"	CR330156	1	
			2.0 mm .079"	CR330157	1	



**Nissan A15 · L4 · 1.5 L · 92 ci**

**Pro-Copper  
Racing Head Gaskets**

For use with o-rings & sealant

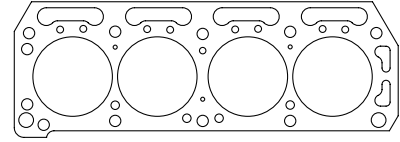

Bore Opening	Thickness								Qty.
	.021"	.032"	.043"	.050"	.062"	.072"	.080"	.093"	
78.2 mm round 3.080"	P916121	P916132	P916143	P916150	P916162	P916172	P916180	P916193	1

**Nissan SR20DE / DET · DOHC · L4 · 2.0 L · 122 ci**

**Pro-Copper  
Racing Head Gaskets**

For use with o-rings & sealant

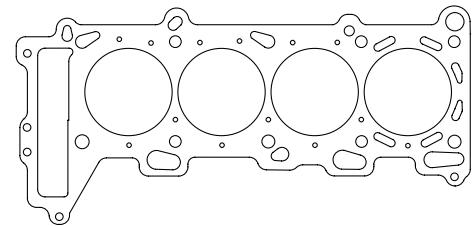

Bore Opening	Thickness								Qty.
	.021"	.032"	.043"	.050"	.062"	.072"	.080"	.093"	
87.9 mm round 3.437"	P916521	P916532	P916543	P916550	P916562	P916572	P916580	P916593	1

**Nissan KA24DE · DOHC · L4 · 2.4 L · 146 ci**

**Pro-Copper  
Racing Head Gaskets**

For use with o-rings & sealant

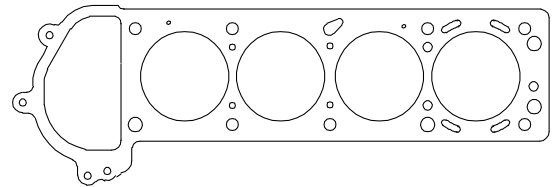

Bore Opening	Thickness								Qty.
	.021"	.032"	.043"	.050"	.062"	.072"	.080"	.093"	
88.9 mm round 3.500"	P916621	P916632	P916643	P916650	P916662	P916672	P916680	P916693	1

**Nissan VG30ET · V6 · 3.0 L · 183 ci**

**Pro-Copper  
Racing Head Gaskets**

For use with o-rings & sealant

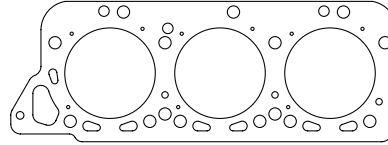

Bore Opening	Thickness								Qty.
	.021"	.032"	.043"	.050"	.062"	.072"	.080"	.093"	
88.9 mm round 3.500"	P925821	P925832	P925843	P925850	P925862	P925872	P925880	P925893	1

**Nissan VG30DET / DETT · V-6 · 3.0 L · 183 ci**

**Pro-Copper  
Racing Head Gaskets**

For use with o-rings & sealant

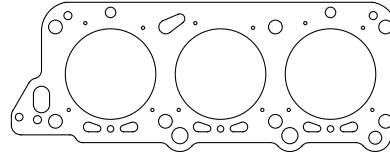

Bore Opening	Thickness								Qty.
	.021"	.032"	.043"	.050"	.062"	.072"	.080"	.093"	
88.9 mm round 3.500"	P916921	P916932	P916943	P916950	P916962	P916972	P916980	P916993	1

**Nissan VQ35DE · DOHC · V6 · 3.5 L · 214 ci**

**Pro-Copper  
Racing Head Gaskets**

For use with o-rings & sealant

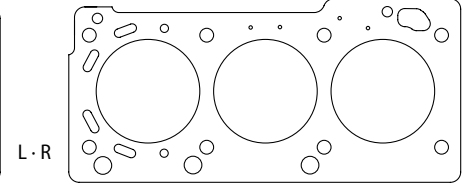
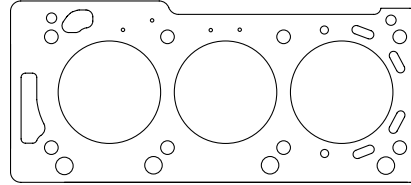

L · R

Bore Opening	Thickness								Qty.
	.021"	.032"	.043"	.050"	.062"	.072"	.080"	.093"	
97.8 mm round 3.850"	P927321L	P927332L	P927343L	P927350L	P927362L	P927372L	P927380L	P927393L	1
	P927321R	P927332R	P927343R	P927350R	P927362R	P927372R	P927380R	P927393R	1

**Titan  
Copper Racing  
Head Gaskets**

Sealed coolant passages,  
for use with o-rings & sealant

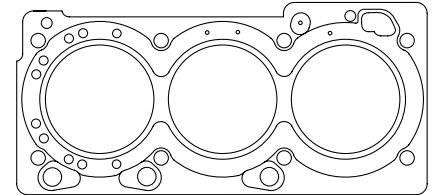
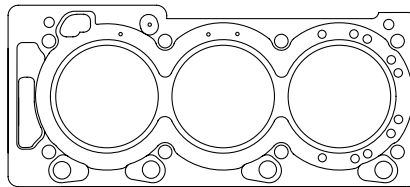

L · R

Bore Opening	Thickness								Qty.
	.021"	.032"	.043"	.050"	.062"	.072"	.080"	.093"	
97.8 mm round 3.850"	-	T927332L	T927343L	T927350L	T927362L	T927372L	T927380L	T927393L	1
		T927332R	T927343R	T927350R	T927362R	T927372R	T927380R	T927393R	1

**ICS  
Copper Racing  
Head Gaskets**

Sealed coolant passages,  
integral combustion o-ring

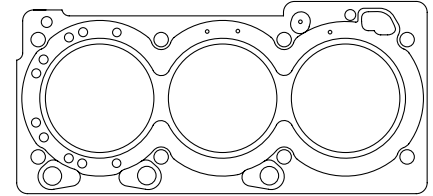
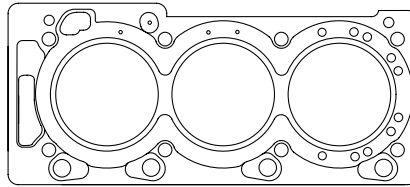

L · R

Bore Opening	Thickness								Qty.
	.021"	.032"	.043"	.050"	.062"	.072"	.080"	.093"	
97.8 mm round 3.850"	-	-	S927343L	S927350L	S927362L	S927372L	S927380L	S927393L	1
			S927343R	S927350R	S927362R	S927372R	S927380R	S927393R	1

**Nissan TB48DE · Patrol · L6 · 4.8 L · 291 ci**

**Pro-Copper  
Racing Head Gaskets**

For use with o-rings & sealant

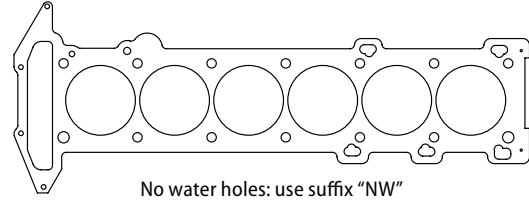
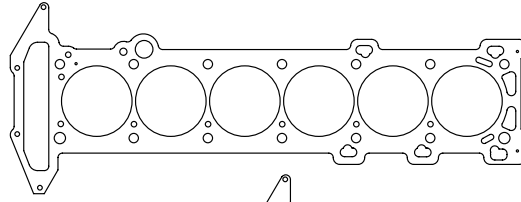

No water holes: use suffix "NW"

Bore Opening	Thickness								Qty.
	.021"	.032"	.043"	.050"	.062"	.072"	.080"	.093"	
100.3 mm round 3.950"	P926221	P926232	P926243	P926250	P926262	P926272	P926280	P926293	1

**Titan  
Copper Racing Head Gaskets**

Sealed coolant passages, for use with o-rings & sealant

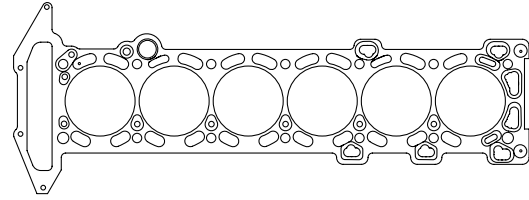

Bore Opening	Thickness								Qty.
	.021"	.032"	.043"	.050"	.062"	.072"	.080"	.093"	
100.3 mm round 3.950"	—	T926232	T926243	T926250	T926262	T926272	T926280	T926293	1

**ICS  
Copper Racing Head Gaskets**

Sealed coolant passages, integral combustion o-ring

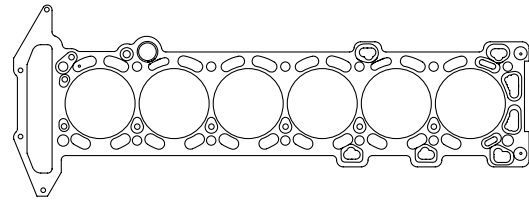

Bore Opening	Thickness								Qty.
	.021"	.032"	.043"	.050"	.062"	.072"	.080"	.093"	
100.3 mm round 3.950"	—	—	S926243	S926250	S926262	S926272	S926280	S926293	1

**Oldsmobile 307-455 · Short Block Gaskets & Seals**

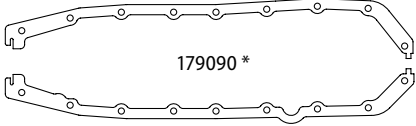
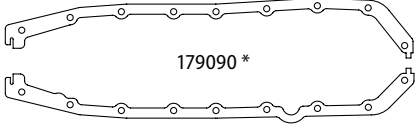
Application	Oil Pan Gasket Set	Timing Cover Gasket Set	Front Cover Gasket Set TC · WP · FP	Water Pump Gasket Set	Fuel Pump Gasket	Water Outlet	Timing Cover Oil Seal	Rear Main Oil Seal	Qty.
<b>1965-90 V8</b> <b>307-350 ci</b> <b>5.0-5.7 L</b>	 <p style="text-align: center;">179090 *</p> <p style="text-align: right;"><b>Accu-Seal E</b> standard gasket materials, nitrile or silicone seals.</p> <p style="text-align: right;">* OEM-style 4-pc set w/ rubberized fiber rails (end seals not pictured).</p>								
	179090 *	17903	17900	17901	17906	17908	17902	17904	1 Set
	79090-10 *	—	7900-10	7901-10	7906-10	7908-10	7902-10	7904-10	Dyno-Pak 10 Sets
<b>1965-76 V8</b> <b>400-455 ci</b> <b>6.6-7.5 L</b>	 <p style="text-align: center;">179090 *</p> <p style="text-align: right;"><b>Accu-Seal E</b> standard gasket materials, nitrile or silicone seals.</p> <p style="text-align: right;">* OEM-style 4-pc set w/ rubberized fiber rails (end seals not pictured).</p>								
	179090 *	17903	17900	17901	17906	17908	17902	17905	1 Set
	79090-10 *	—	7900-10	7901-10	7906-10	7908-10	7902-10	7905-10	Dyno-Pak 10 Sets
	<p><b>Accu-Seal Pro</b> premium gasket materials · † Severe Duty™, .093" thick PTFE-coated, steel-core material.</p>								
	279090 †	—	—	—	—	—	—	—	1 Set
279090-10 †	—	—	—	—	—	—	—	Dyno-Pak 10 Sets	

**Oldsmobile 307-455 · SBBK – Short Block Base Kit**

Provides remaining gaskets & seals common to the engine type, regardless of customization.

**NEW!**  
— SEE P.8 —

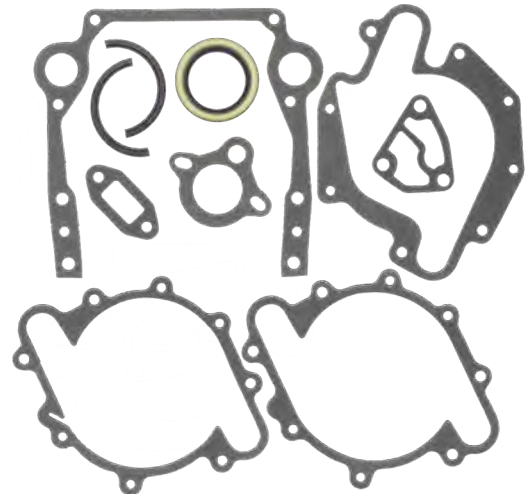

Application	SBBK Gasket / Oil Seal Kit	Contents of Kit
<b>1964-82 V8</b> <b>307-350 ci</b> <b>5.4-5.7 L</b>	37903	<p><b>Includes:</b>                      Timing Cover · Water Pump · Fuel Pump · Water Outlet Gasket · Oil Filter Mount Gasket · Timing Cover Seal · 2-pc Rear Main Seal</p>
<b>1967-76 V8</b> <b>400-455 ci</b> <b>6.6-7.5 L</b>	37904	<p><b>Includes:</b>                      Timing Cover · Water Pump · Fuel Pump · Water Outlet Gasket · Oil Filter Mount Gasket · Timing Cover Seal · 2-pc Rear Main Seal</p>



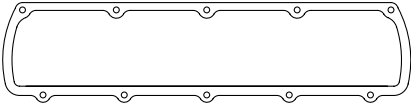

## Oldsmobile 307-455 · Valve Cover Gaskets

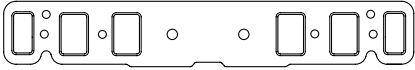
Application	Hi-Density Cork 3/16" Thick	Hi-Density Cork 5/16" Thick	Tuff-Bak Laminated Cork		Steel Core PTFE-Coated .093" Thick (3/32")	Qty.
			1/8" Thick	1/4" Thick		
	Street / Strip			Racing / Hi-Vac		
1965-76 V8 307-455 ci 5.0-7.5 L	 <p>10 bolts, 5-over-5 perimeter pattern. Fits all including after-market heads.</p>					
	179075	179076	279175	279176	279178	1 set
	-	79076-10	279175-10	279176-10	279178-10	Dyno-Pak 10 Sets

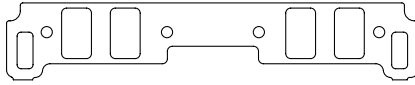
## Oldsmobile 307-455 · Intake Gaskets

Application — Port Size	Thickness	Accu-Seal E Standard Material		Accu-Seal Pro · Premium Materials		
		Packaged 1 Set	Dyno-Pak · 10 Sets	Packaged 1 Set	Dyno-Pak · 10 Sets	
1965-76 V8 307-350 ci 5.0-7.5 L — 1.30" x 2.00" Rectangle	 <p>† Silicone Bead Sealed Ports</p>					
	.062"	179101	79101-10	279101 †	279101-10 †	
1967-76 V8 400-455 ci 6.6-7.5 L — 1.40" x 2.40" Rectangle	 <p>Also fits Edelbrock Performer RPM Olds — † Silicone Bead Sealed Ports</p>					
	.062"	179102	79102-10	279102 †	279102-10 †	
<b>Racing Derivatives</b>						
Batten Olds — 1.35" x 2.25" Rectangle	 <p>Fits "as-cast ports"</p>					
	.062"	179103	79103-10	279103	279103-10	
Batten Olds — 1.50" x 2.53" Rectangle	 <p>Fits race-ported heads</p>					
	.062"	179104	79104-10	279104	279104-10	

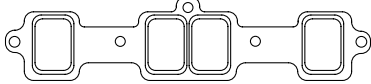
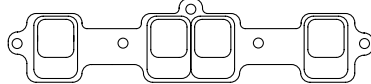
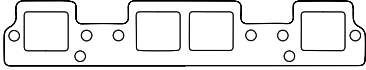
**Oldsmobile 307-455 · Exhaust Gaskets**

Application — Port Size	Accu-Seal E		<i>Accu-Seal Pro</i>		<i>Graph-Form</i>	<i>Pro-Copper</i>	
	Standard Material .062"		Premium Material .062"		Hi-Density Graphite .150"	Embossed .043"	Flat-Annealed .062"
	Packaged 1 Set	Dyno-Pak 10 Sets / 20 Pc	Packaged 1 Set	Dyno-Pak 10 Sets / 20 Pc	Packaged 1 Set	Packaged 1 Set	Packaged 1 Set
<b>1967-76 V8 400-455 ci 6.6-7.5 L</b> — <b>1.47" x 2.10" Rectangle</b>	 <p>Port size matches the head, embossment matches manifold &amp; most headers</p>						
	179080	79080-10	279180	79180-10	479180	4079	E79186
<b>1967-76 V8 Edelbrock Aluminum Head 400-455 ci 6.6-7.5 L</b> — <b>1.48" x 1.50" Square</b>	 <p>Port size matches Edelbrock Performer RPM Olds</p>						
	179081	-	-	-	479181	4179	E79286
<b><i>Racing Derivatives</i></b>							
<b>Batten Olds</b> — <b>1.80" x 1.57" Rectangle</b>							
	179082	79082-10	279182	79182-10	-	479182	-
<b>Bulldog Raised Port</b> — <b>2.37" Round</b>							
	179083	79083-10	279183	79183-10	-	479183	-

**Oldsmobile 400-455**  
**Accu-Seal Pro · Performance Head Gaskets**

Application	Image	Bore Opening	Compr. Thickness	Part Number	Description	Qty.
1965-76 V8 400-455 ci 6.6-7.5 L		4.270"	.045"	5792745	Composite and steel construction.	1

**Oldsmobile 330-455**  
**MLS Spartan · Performance Head Gaskets**

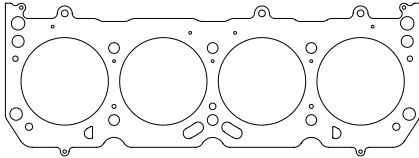
Application	Image	Bore Opening	Compr. Thick.	Part Number	Description	Qty.
1964-69 V8 330-400 ci 5.4-5.6 L		4.100"	.039"	M791039	MLS embossed stainless steel construction.	1
1968-76 V8 425, 455 ci 7.0-7.5 L		4.270"	.039"	M792739		1
		4.270"	.051"	M792751		1
		4.270"	.062"	M792762		1
1977-79 V8 403 ci 6.6 L		4.410"	.039"	M794139		1
		4.410"	.051"	M794151		1
		4.410"	.062"	M794162		1
<b>Marine Use:</b> stainless steel construction, all MLS Spartan head gaskets are suitable for use in marine applications.						



**Oldsmobile · V8 · 330-455 ci · 5.4-7.5 L**

**Pro-Copper  
Racing Head Gaskets**

For use with o-rings & sealant

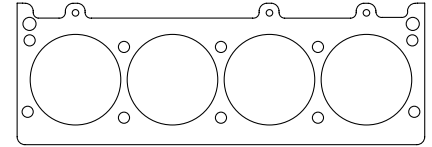
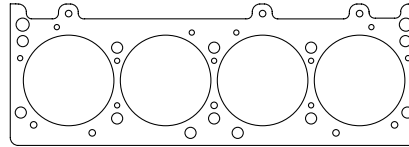

No water holes: use suffix "NW"

Bore Opening	Thickness								Qty.
	.021"	.032"	.043"	.050"	.062"	.072"	.080"	.093"	
4.200" round	P792021	P792032	P792043	P792050	P792062	P792072	P792080	P792093	1
4.250" round	P792521	P792532	P792543	P792550	P792562	P792572	P792580	P792593	1
4.320" round	P793221	P793232	P793243	P793250	P793262	P793272	P793280	P793293	1
4.380" round	P793821	P793832	P793843	P793850	P793862	P793872	P793880	P793893	1

**Titan  
Copper Racing Head Gaskets**

Sealed coolant passages, for use with o-rings & sealant

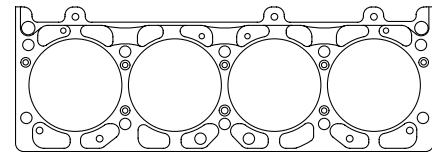

Bore Opening	Thickness								Qty.
	.021"	.032"	.043"	.050"	.062"	.072"	.080"	.093"	
4.200" round	-	T792032	T792043	T792050	T792062	T792072	T792080	T792093	1
4.250" round	-	T792532	T792543	T792550	T792562	T792572	T792580	T792593	1
4.320" round	-	T793232	T793243	T793250	T793262	T793272	T793280	T793293	1
4.380" round	-	T793832	T793843	T793850	T793862	T793872	T793880	T793893	1

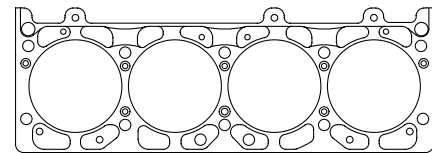

**ICS  
Copper Racing Head Gaskets**

Sealed coolant passages, integral combustion o-ring

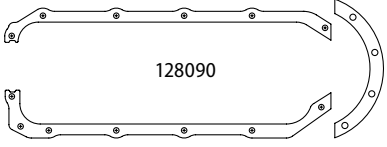
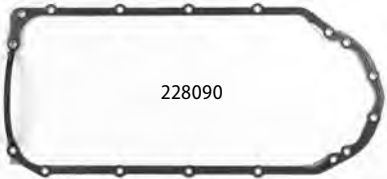
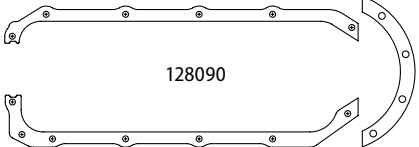

Bore Opening	Thickness								Qty.
	.021"	.032"	.043"	.050"	.062"	.072"	.080"	.093"	
4.200" round	-	-	S792043	S792050	S792062	S792072	S792080	S792093	1
4.250" round	-	-	S792543	S792550	S792562	S792572	S792580	S792593	1
4.320" round	-	-	S793243	S793250	S793262	S793272	S793280	S793293	1
4.380" round	-	-	S793843	S793850	S793862	S793872	S793880	S793893	1

**Pontiac 326-455 - Short Block Gaskets & Seals**

Application	Oil Pan Gasket Set	Timing Cover Gasket Set	Front Cover Gaskets TC, WP, FP	Water Pump Gasket Set	Fuel Pump Gasket	Water Outlet Gasket	Timing Cover Oil Seal	Rear Main Oil Seal	Qty.
<b>1963-79 V8 301-400 ci 5.0-6.6 L</b>	 <p style="text-align: center;">128090</p> <p style="text-align: right;"><b>Accu-Seal E</b> standard gasket materials, nitrile or silicone seals.</p>								
	128090	12803	12800	12801	11106 <i>supersedes 12806</i>	11108 <i>supersedes 12808</i>	12802	-	1 Set
	28090-10	-	2800-10	2801-10	1106-10 <i>supersedes 2806-10</i>	1108-10 <i>supersedes 2808-10</i>	2802-10		Dyno-Pak 10 Sets
	 <p style="text-align: center;">228090</p> <p style="text-align: right;"><b>Accu-Seal Pro</b> premium gasket materials, FKM seals, molded water outlet.</p>								
	228090 1 pc. molded silicone	-	-	-	-	-	-	-	22804 2 pc FKM
-	-	-	-	-	-	-	-	2804-10 Dyno-Pak	Dyno-Pak 10 Sets
<b>1961-76 V8 421-455 ci 6.9-7.5 L</b>	 <p style="text-align: center;">128090</p> <p style="text-align: right;"><b>Accu-Seal E</b> standard gasket materials, nitrile or silicone seals.</p>								
	128090	12803	12800	12801	11106 <i>supersedes 12806</i>	11108 <i>supersedes 12808</i>	12802	-	1 Set
	28090-10	-	2800-10	2801-10 Dyno-Pak	1106-10 Dyno-Pak <i>supersedes 2806-10</i>	1108-10 Dyno-Pak <i>supersedes 2808-10</i>	2802-10 Dyno-Pak		Dyno-Pak 10 Sets
	 <p style="text-align: center;">228090</p> <p style="text-align: right;"><b>Accu-Seal Pro</b> premium gasket materials, FKM seals, molded water outlet.</p>								
	228090 1 pc. molded silicone	-	-	-	-	-	-	-	22805 2 pc. FKM
-	-	-	-	-	-	-	-	2805-10 Dyno-Pak	Dyno-Pak 10 Sets

**Pontiac 326-455 · SBBK – Short Block Base Kit**

Provides remaining gaskets & seals common to the engine type, regardless of customization.



**NEW!**  
— SEE P.8 —

Application	SBBK Gasket / Oil Seal Kit	Contents of Kit	
1961-76 V8 421, 455 ci · 6.9-7.5 L	32804	<b>Includes:</b> Timing Cover · Water Pump · Fuel Pump · Water Outlet Gasket · Timing Cover Seal · 2-pc Rope Rear Main Seal	
1963-79 V8 301-400 c · 5.0-6.5 L	42803	<b>Includes:</b> Timing Cover · Water Pump · Fuel Pump · Water Outlet Gasket · Timing Cover Seal · 2-pc FKM Rear Main Seal	
1961-76 V8 421, 455 ci · 6.9-7.5 L	42804	<b>Includes:</b> Timing Cover · Water Pump · Fuel Pump · Water Outlet Gasket · Timing Cover Seal · 2-pc FKM Rear Main Seal	

**Pontiac 326-455 · Valve Cover Gaskets**

Application	Rubberized Fiber .093" Thick (3/32")	Hi-Density Cork 5/16" Thick	Tuff-Bak Laminated Cork		Steel Core PTFE-Coated .093" Thick (3/32")	Qty.						
			1/8" Thick	1/4" Thick								
	Street / Strip		Racing / Hi-Vac		Severe Duty™							
1963-76 V8 301-455 ci 5.0-7.5 L												
							-	128076	228175	228176	-	1 Set
		28076-10	28175-10	28176-10		Dyno-Pak 10 Sets						
1963-76 V8 301-455 ci 5.0-7.5 L · Valley Pan Gasket												
							128074	-	-	-	-	1 Set
							128074-10	-	-	-	-	Dyno-Pak 10 Sets

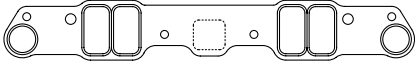
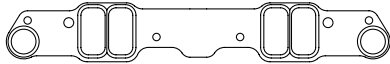
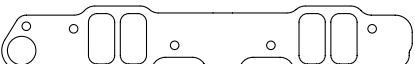
## Pontiac 326-455 · Intake Gaskets

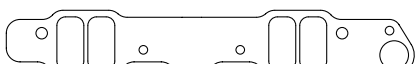
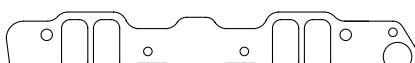
Application — Port Size	Thickness	Accu-Seal E Standard Material		Accu-Seal Pro · Premium Materials	
		Packaged 1 Set	Dyno-Pak · 10 Sets	Packaged 1 Set	Dyno-Pak · 10 Sets
<b>1963-76 · V8</b> <b>326-400 ci</b> <b>5.3-6.6 L</b> — <b>1.07" x 2.02"</b> <b>Rectangle</b>	 † Silicone Bead Sealed Ports				
	.062"	128101	28101-10	228101 †	228101-10 †
<b>1969-74</b> <b>V8 · Ram Air 4,</b> <b>Super Duty, HO</b> <b>400-455 ci</b> <b>6.6-7.5 L</b> — <b>1.23" x 2.40"</b> <b>Rectangle</b>	 Also fits Edelbrock Performer & Performer RPM Pontiac aluminum heads — † Silicone Bead Sealed Ports				
	.062"	128107	28107-10	228107 †	228107-10 †
<b>Modified</b> <b>Small Port</b> <b>326-400 ci</b> <b>5.3-6.6 L</b> — <b>1.06" x 2.10"</b> <b>Rectangle</b>					
	.062"	128102	28102-10	228102	228102-10
<b>Modified</b> <b>Large Port</b> <b>326-400 ci</b> <b>5.3-6.6 L</b> — <b>1.17" x 2.30"</b> <b>Rectangle</b>	 † Silicone Bead Sealed Ports				
	.062"	128103	28103-10	228103 †	228103-10 †
<b>Modified XL Port</b> <b>326-400 ci</b> <b>5.3-6.6 L</b> — <b>1.12" x 2.24"</b> <b>Rectangle</b>	 Gasket shape provides extra material at top for porting				
	.062"	128104	28104-10	228104	228104-10
<b>Modified XL Port</b> <b>326-400 ci</b> <b>5.3-6.6 L</b> — <b>1.17" x 2.30"</b> <b>Rectangle</b>					
	.062"	128105	28105-10	228105	228105-10
<b>Modified XL Port</b> <b>326-400 ci</b> <b>5.3-6.6 L</b> — <b>Rectangle</b> <b>1.13" x 2.35"</b>					
	.062"	128106	28106-10	228106	228106-10

**Pontiac 326-455 · Exhaust Gaskets**

Application — Port Size	Accu-Seal E		Accu-Seal Pro		Graph-Form	Pro-Copper	
	Standard Material .062"		Premium Material .062"		Hi-Density Graphite .150"	Embossed .043"	Flat-Annealed .062"
	Packaged 1 Set	Dyno-Pak 10 Sets	Packaged 1 Set	Dyno-Pak 10 Sets	Packaged 1 Set	Packaged 1 Set	Packaged 1 Set
1963-76 V8 326-455 ci 5.3-7.5 L — 1.90" D-Port			Gaskets match 455ci factory heads with 'D' center ports & oval outer ports				
	128080	28080-10	228180	28180-10	428180	4128	E28186
1969-74 Ram Air 4, Super Duty, HO 400-455 ci 6.6-7.5 L — 1.76" Round			Gaskets match 400-455ci factory Ram Air IV heads with round ports				
	128081	28081-10	228181	28181-10	428181	4028	E28286
1969-74 Ram Air 4, Super Duty, HO 400-455 ci 6.6-7.5 L — 2.00" Round			Fits Edelbrock Performer & Performer RPM Pontiac heads with 2" Ram Air style headers				
	—	—	—	—	—	4228	—

**Pontiac 326-455 · Accu-Seal Pro · Performance Head Gaskets**

Application	Image	Bore Opening	Compr. Thick.	Part Number	Description	Qty.
1963-76 V8 326-455 ci 5.3-7.5 L		4.190"	.045"	5281945	Composite and steel construction.	1

**Pontiac 326-455 · MLS Spartan Performance Head Gaskets**

Application	Image	Bore Opening	Compr. Thick.	Part Number	Description	Qty.
1963-76 V8 326-455 ci 5.3-7.5 L		4.200"	.039"	M282039	MLS embossed stainless steel construction.	1
		4.270"	.039"	M282739		1

**Marine Use:** stainless steel construction, all MLS Spartan head gaskets are suitable for use in marine applications.

**Pontiac V8 · 326-455 ci · 5.3-7.5 L**

**Pro-Copper  
Racing Head Gaskets**

For use with o-rings & sealant

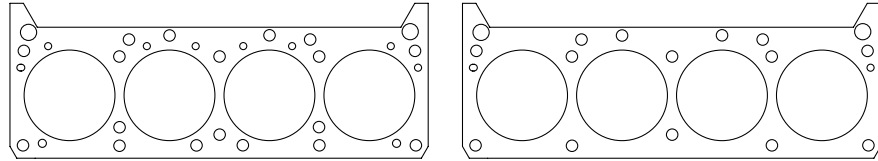

No water holes: use suffix "NW"

Bore Opening	Thickness								Qty.
	.021"	.032"	.043"	.050"	.062"	.072"	.080"	.093"	
4.160" round	P281521	P281532	P281543	P281550	P281562	P281572	P281580	P281593	1
4.200" round	P282021	P282032	P282043	P282050	P282062	P282072	P282080	P282093	1
4.250" round	P282521	P282532	P282543	P282550	P282562	P282572	P282580	P282593	1
4.320" round	P283221	P283232	P283243	P283250	P283262	P283272	P283280	P283293	1
4.380" round	P283821	P283832	P283843	P283850	P283862	P283872	P283880	P283893	1

**Titan  
Copper Racing Head Gaskets**

Sealed coolant passages, for use with o-rings & sealant

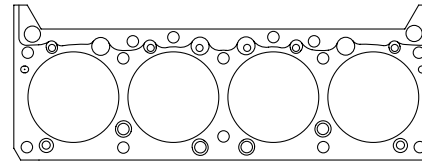

Bore	Thickness								Qty.
	.021"	.032"	.043"	.050"	.062"	.072"	.080"	.093"	
4.160" round	–	T281532	T281543	T281550	T281562	T281572	T281580	T281593	1
4.200" round	–	T282032	T282043	T282050	T282062	T282072	T282080	T282093	1
4.250" round	–	T282532	T282543	T282550	T282562	T282572	T282580	T282593	1
4.320" round	–	T283232	T283243	T283250	T283262	T283272	T283280	T283293	1
4.380" round	–	T283832	T283843	T283850	T283862	T283872	T283880	T283893	1

**ICS  
Copper Racing Head Gaskets**

Sealed coolant passages, integral combustion o-ring

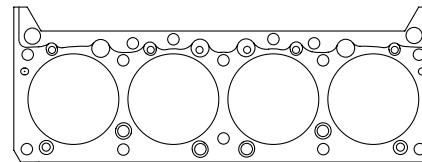

Bore Opening	Thickness								Qty.
	.021"	.032"	.043"	.050"	.062"	.072"	.080"	.093"	
4.160" round	–	–	S281543	S281550	S281562	S281572	S281580	S281593	1
4.200" round	–	–	S282043	S282050	S282062	S282072	S282080	S282093	1
4.250" round	–	–	S282543	S282550	S282562	S282572	S282580	S282593	1
4.320" round	–	–	S283243	S283250	S283262	S283272	S283280	S283293	1
4.380" round	–	–	S283843	S283850	S283862	S283872	S283880	S283893	1

**Porsche · Vulcan Cut-Ring · Performance Head Gaskets**

Application	Image	Bore Opening	Compr. Thickness	Part Number	Description	Qty.
<b>1988-95</b> <b>968</b> <b>M44.11 / .12 / .41 / .43 / .44</b> <b>L4</b> <b>2.7-3.0 L</b> <b>165-183 ci</b>		105 mm 4.134"	1.6 mm .063"	CR330043	Stainless steel Cut-Ring combustion seals (not pictured).  Composite gasket body construction.	1
<b>1986-90</b> <b>944 Turbo</b> <b>M44 / 51 / 52</b> <b>L4</b> <b>2.5 L · 153 ci</b>		102 mm 4.015"	1.4 mm .055"	CR330137		1
		105 mm 4.134"	1.6 mm .063"	CR330138		1
<b>2014-Up</b> <b>911 / 9A1</b> <b>Flat 6</b> <b>3.8 L</b> <b>232 ci</b>		103 mm 4.055"	1.0 mm .039"	CR330092L <i>Left</i>	Stainless steel Cut-Ring combustion seals.  Composite gasket body construction.	1
				CR330093R <i>Right</i>		1
		105 mm 4.134"	1.0 mm .039"	CR330135L <i>Left</i>	1	
				CR330136R <i>Right</i>	1	

## Subaru · Exhaust Gaskets

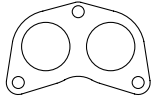
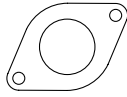
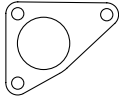
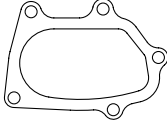
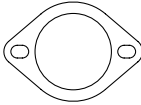
Application — Port Size	Accu-Seal E		Accu-Seal Pro		Pro-Copper	
	Standard Material .062"		Premium Material .062"		Embossed .043"	Flat-Annealed .062"
	Packaged 1 Pc.	Dyno-Pak 10 Pcs.	Packaged 1 Pc.	Dyno-Pak 10 Pcs.	Packaged 1 Pc.	Packaged 1 Pc.
<b>2002-Up</b> EJ20 / EJ25 · Boxer Impreza WRX 122-150 ci · 2.0-2.5 L — 1.76" Round					3-Bolt Header Gasket	
<b>1992-Up</b> EJ20 / EJ25 · Boxer Impreza WRX 122-150 ci · 2.0-2.5 L — 1.87" Round					Header to Turbo Pipe	
<b>1992-Up</b> EJ20 / EJ25 · Boxer Impreza WRX 122-150 ci · 2.0-2.5 L — 2.00" Round					3-Bolt Turbine Inlet	
<b>2002-Up</b> EJ20 / EJ25 · Boxer Impreza WRX 122-150 ci · 2.0-2.5 L — Irregular					5-Bolt Turbine Outlet	
<b>1992-Up</b> EJ20 / EJ25 · Boxer Impreza WRX 122-150 ci · 2.0-2.5 L — 3.00" Round					2-Bolt 3" Flange Gasket	



**Subaru · MLS Spartan GS Performance Head Gaskets**

Application	Image	Bore Opening	Compr. Thickness	Part Number	Description	Qty.
<b>2012-Up Boxer FA20F DOHC 2.0 L 122 ci</b>		89.5 mm 3.524"	0.80 mm .032"	M338489GSR <i>Right</i>	MLS Spartan with <b>Gas-Stopper</b> embossed stainless steel construction.	1
			0.80 mm .032"	M338490GSL <i>Left</i>		1
			0.95 mm .038"	M338491GSR <i>Right</i>		1
			0.95 mm .038"	M338492GSL <i>Left</i>		1
<b>1991-Up Boxer EJ20 / EJ205 DOHC / EJ20 EMPI EJ20E / EJ20J 2.0 L 122 ci</b>		94.0 mm 3.701"	0.90 mm .035"	M338460GS	1	
			1.0 mm .039"	M338002GS	1	
			1.3 mm .051"	M338001GS	1	
<b>1998-2012 Boxer EJ205 DOHC / EJ20 EMPI 2.0 L 122 ci</b>		100.0 mm 3.938"	0.95 mm .038"	M338448GS <i>14 mm head bolt / stud holes</i>	1	
			1.0 mm .039"	M338235GS	1	
			1.3 mm .051"	M338255GS	1	
			1.9 mm .075"	M338325GS	1	
		101 mm 3.977"	.95 mm .038"	M338455GS	1	
		102.3 mm 4.028"	1.0 mm .039"	M338372GS	1	
1.3 mm .051"	M338405GS		1			
<b>2006-Up Boxer EJ255 / EJ257 EJ25DET 2.5 L 150 ci</b>		101.3 mm 3.989"	1.0 mm .039"	M338465GS <i>14 mm head bolt / stud holes</i>	1	

**Marine Use:** stainless steel construction, all MLS Spartan head gaskets are suitable for use in marine applications.

**Subaru · Vulcan Cut-Ring · Performance Head Gaskets**

Application	Image	Bore Opening	Compr. Thickness	Part Number	Description	Qty.
<b>1991-Up L4 EJ20-E-J / EJ205 (DHO) / EJ20 EMPI 2.0 L 122 ci</b>		93.5 mm 3.682"	1.2 mm .047"	CR330041		1
				CR330130 <i>14 mm head bolt / stud holes</i>		1
<b>1998-12 L4 EJ25 / EJ251 / EJ25 / EJ255 / EJ257 2.5 L 150 ci</b>		95 mm 3.741"	1.2 mm .047"	CR330080 <i>14 mm head bolt / stud holes</i>	Stainless steel Cut-Ring combustion seals (not pictured).  Composite gasket body construction.	1
		99 mm 3.898"	1.2 mm .047"	CR330079 <i>14 mm head bolt / stud holes</i>		1
		100 mm 3.938"	1.2 mm .047"	CR330040 <i>12 mm head bolt / stud holes</i>		1
			1.2 mm .047"	CR330076 <i>14 mm head bolt / stud holes</i>		1
		101.3 mm 3.989"	1.0 mm .039"	CR330131		1
			1.2 mm .047"	CR330066		1
		103.5 mm 4.074"	1.2 mm .047"	CR330078 <i>14 mm head bolt / stud holes</i>		1
			1.4 mm .055"	CR330091		1
<b>2006-Up Boxer EJ255 / EJ257 EJ25DET 2.5 L 150 ci</b>		101.3 mm 3.989"	1.2 mm .047"	CR330081 <i>14 mm head bolt / stud holes</i>		1

**Subaru Boxer · EJ20 · 2.0 L · 122 ci**

**Pro-Copper  
Racing Head Gaskets**

For use with o-rings & sealant

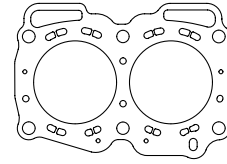

Bore Opening	Thickness								Qty.
	.021"	.032"	.043"	.050"	.062"	.072"	.080"	.093"	
95.3mm 3.750" round	P927621	P927632	P927643	P927650	P927662	P927672	P927680	P927693	1
97.8mm 3.850" round	P927721	P927732	P927743	P927750	P927762	P927772	P927780	P927793	1

**Titan  
Copper Racing Head Gaskets**

Sealed coolant passages, for use with o-rings & sealant

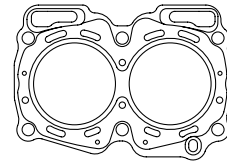

Bore Opening	Thickness								Qty.
	.021"	.032"	.043"	.050"	.062"	.072"	.080"	.093"	
95.3mm 3.750" round	–	T927632	T927643	T927650	T927662	T927672	T927680	T927693	1
97.8mm 3.850" round	–	T927732	T927743	T927750	T927762	T927772	T927780	T927793	1

**ICS  
Copper Racing Head Gaskets**

Sealed coolant passages, integral combustion o-ring

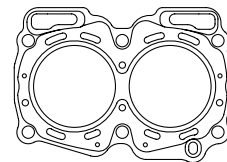

Bore Opening	Thickness								Qty.
	.021"	.032"	.043"	.050"	.062"	.072"	.080"	.093"	
95.3mm 3.750" round	–	–	S927643	S927650	S927662	S927672	S927680	S927693	1
97.8mm 3.850" round	–	–	S927743	S927750	S927762	S927772	S927780	S927793	1

**Subaru Boxer · EJ25 · 2.5 L · 150 ci**

**Pro-Copper  
Racing Head Gaskets**

For use with o-rings & sealant

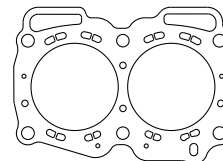

Bore Opening	Thickness								Qty.
	.021"	.032"	.043"	.050"	.062"	.072"	.080"	.093"	
100.3mm 3.950" round	P927821	P927832	P927843	P927850	P927862	P927872	P927880	P927893	1
101.9mm 4.010" round	P924921	P924932	P924943	P924950	P924962	P924972	P924980	P924993	1
103.1mm 4.060" round	P927921	P927932	P927943	P927950	P927962	P927972	P927980	P927993	1

**Titan  
Copper Racing Head Gaskets**

Sealed coolant passages, for use with o-rings & sealant

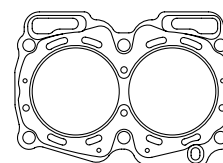

Bore Opening	Thickness								Qty.
	.021"	.032"	.043"	.050"	.062"	.072"	.080"	.093"	
100.3mm 3.950" round	–	T927832	T927843	T927850	T927862	T927872	T927880	T927893	1
101.9mm 4.010" round	–	T924932	T924943	T924950	T924962	T924972	T924980	T924993	1
103.1mm 4.060" round	–	T927932	T927943	T927950	T927962	T927972	T927980	T927993	1

**ICS  
Copper Racing Head Gaskets**

Sealed coolant passages, integral combustion o-ring

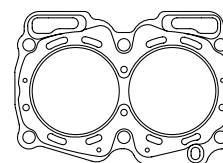

Bore Opening	Thickness								Qty.
	.021"	.032"	.043"	.050"	.062"	.072"	.080"	.093"	
100.3mm 3.950" round	–	–	S927843	S927850	S927862	S927872	S927880	S927893	1
101.9mm 4.010" round	–	–	S924943	S924950	S924962	S924972	S924980	S924993	1
103.1mm 4.060" round	–	–	S927943	S927950	S927962	S927972	S927980	S927993	1

## Toyota · Intake Gaskets

Application	Thickness	Accu-Seal E Standard Material		Accu-Seal Pro · Premium Materials	
		Packaged 1 Pc.	Dyno-Pak · 10 Pcs.	Packaged 1 Pc.	Dyno-Pak · 10 Pcs.
1981-85 22R SOHC · L4 2.4 L · 144 ci	1.6 mm .062"	918411	918411-10	918412	918412-10
	1.6 mm .062"	926311	926311-10	926312	926312-10

## Toyota · Exhaust Gaskets

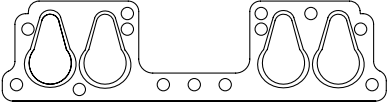
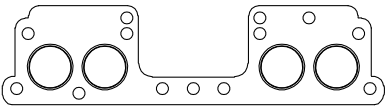
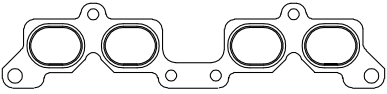
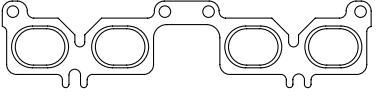
Application — Port Size	Accu-Seal E		Accu-Seal Pro		Pro-Copper	
	Standard Material 1.6 mm / .062"		Premium Material 1.6 mm / .062"		Embossed 1.1 mm / .043"	Flat-Annealed 1.6 mm / .062"
	Packaged 1 Pc.	Dyno-Pak 10 Pcs.	Packaged 1 Pc.	Dyno-Pak 10 Pcs.	Packaged 1 Pc.	Dyno-Pak 10 Pcs.
1975-95 22R · L4 2.4 L · 144 ci — Teardrop					Note: Raised bead headers must match embossment	
					—	—
1975-95 22R · L4 with Race Port 2.4 L · 144 ci — 1.50" Round					Fits racing heads with weld-filled round exhaust ports & round port headers	
					—	—
1986-00 3S-FE / 5S-FE L4 2.0-2.2 L 122-132 ci — 1.87" x 1.37" Oval					Note: Raised bead headers must match embossment	
					—	—
1995-04 2RZ-FE / 3RZ-FE L4 2.4-2.7 L 146-168 ci — 1.87" x 1.37" Oval					Note: Raised bead headers must match embossment	
					—	—

## Toyota · Exhaust Gaskets

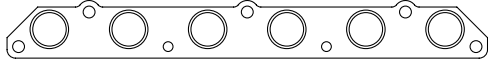
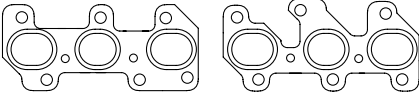
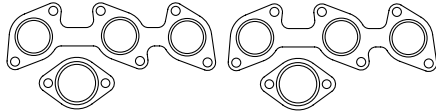
Application — Port Size	Accu-Seal E		Accu-Seal Pro		Pro-Copper	
	Standard Material 1.6 mm / .062"		Premium Material 1.6 mm / .062"		Embossed 1.1 mm / .043"	Flat-Annealed 1.6 mm / .062"
	Packaged 1 Set	Dyno-Pak 10 Sets	Packaged 1 Set	Dyno-Pak 10 Sets	Packaged 1 Set	Packaged 1 Set
<b>1986-92</b> <b>7M-GTE</b> <b>L6</b> <b>3.0 L · 183 ci</b> — <b>1.50" Round</b>					Note: Raised bead headers must match embossment. Set contains 1 pc.	
	—		—		9420 1 pc.	—
<b>1991-02</b> <b>2JZ-GTE</b> <b>L6</b> <b>3.0 L · 183 ci</b> — <b>1.63" x 1.26" Oval</b>					Note: Raised bead headers must match embossment.	
	—		—		9439 2 pcs.	—
<b>1996-03</b> <b>5VZ-FE</b> <b>V6</b> <b>3.4 L · 206 ci</b> — <b>1.62" Round</b>					Note: Raised bead headers must match embossment.	
	—		—		9465 4 pcs.	—

**Toyota · MLS Spartan Performance Head Gaskets**

Application	Image	Bore Opening	Compr. Thickness	Part Number	Description	Qty.
<b>1993-Up</b> <b>2JZ-GE/GTE</b> <b>L6</b> <b>3.0 L</b> <b>183 ci</b>		87.7 mm 3.453"	1.3 mm .051"	M338204	MLS Spartan embossed stainless steel construction.	1
		87.0 mm 3.426"	1.5 mm .059"	M338416		1
<b>1992-97</b> <b>4E-FE / 5E-FE</b> <b>L4</b> <b>1.3-1.4 L</b> <b>79-85 ci</b>		75.5 mm 2.973"	0.85 mm .033"	M338374GS	MLS Spartan with <i><b>Gas-Stopper</b></i> embossed stainless steel construction.	1
			1.2 mm .047"	M338007GS		1
			1.4 mm .055"	M338011GS		1
			1.9 mm .075"	M338259GS		1
<b>1984-92</b> <b>4A-GE/GEC</b> <b>L4</b> <b>1.6 L</b> <b>98 ci</b>		81.0 mm 3.189"	1.0 mm .039"	M338213GS	MLS Spartan with <i><b>Gas-Stopper</b></i> embossed stainless steel construction.	1
			1.0 mm .039"	M338323GS		1
		83.0 mm 3.268"	1.3 mm .051"	M338324GS		1
			1.9 mm .075"	M338224GS		1
<b>1989-97</b> <b>3S-GE/GTE</b> <b>L4</b> <b>2.0 L</b> <b>122 ci</b>		87.0 mm 3.426"	1.0 mm .039"	M338212GS	MLS Spartan with <i><b>Gas-Stopper</b></i> embossed stainless steel construction.	1
			1.2 mm .047"	M338257GS		1
			1.3 mm .051"	M338326GS		1
			1.4 mm .055"	M338258GS		1
<b>1992-97</b> <b>1FZ-FE</b> <b>L6</b> <b>4.5 L</b> <b>273 ci</b>		101.5 mm 3.997"	0.8 mm .032"	M338440GS	MLS Spartan with <i><b>Gas-Stopper</b></i> embossed stainless steel construction.	1
			1.6 mm .063"	M338441GS		1
			1.95 mm .077"	M338442GS		1
		103.0 mm 4.056"	1.1 mm .045"	M338423GS		1
			1.15 mm .045"	M338443GS		1
			1.95 mm .077"	M338444GS		1

**Marine Use:** stainless steel construction, all MLS Spartan head gaskets are suitable for use in marine applications.

**Toyota • Vulcan Cut-Ring • Performance Head Gaskets**

Application	Image	Bore Opening	Compr. Thickness	Part Number	Description	Qty.
1993-Up 2JZ-GE/GTE L6 3.0 L 183 ci		87.0 mm 3.426"	1.6 mm .063"	CR330044	Stainless steel Cut-Ring combustion seals (not pictured).  Composite gasket body construction.	1
2020-Up Supra Mark V B58 L6 3.0 L 183 ci		83.0 mm 3.267"	1.0 mm	CR330154		1
		84.0 mm 3.307"	1.0 mm	CR330155	1	

**Toyota • 20R / 22R SOHC • 2.2-2.4 L • 134-146 ci**

**Pro-Copper  
Racing Head Gaskets**

For use with o-rings & sealant

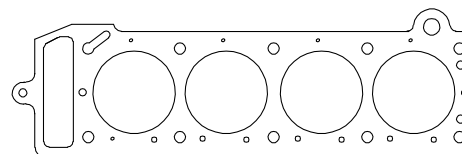

Bore Opening	Thickness								Qty.
	.021"	.032"	.043"	.050"	.062"	.072"	.080"	.093"	
95.3 mm round 3.750"	P918421	P918432	P918443	P918450	P918462	P918472	P918480	P918493	1

**Titan  
Copper Racing Head Gaskets**

Sealed coolant passages, for use with o-rings & sealant

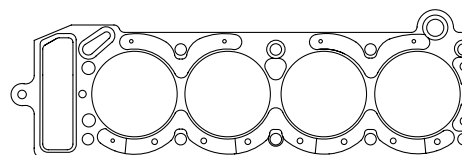

Bore Opening	Thickness								Qty.
	.021"	.032"	.043"	.050"	.062"	.072"	.080"	.093"	
95.3 mm round 3.750"	-	T918432	T918443	T918450	T918462	T918472	T918480	T918493	1

**ICS  
Copper Racing Head Gaskets**

Sealed coolant passages, integral combustion o-ring

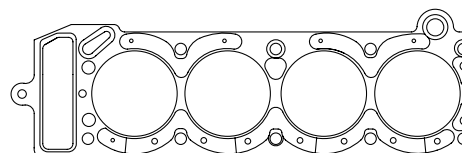

Bore Opening	Thickness								Qty.
	.021"	.032"	.043"	.050"	.062"	.072"	.080"	.093"	
95.3 mm round 3.750"	-	-	S918443	S918450	S918462	S918472	S918480	S918493	1



**Toyota · 2RZFE / 3RZFE DOHC · 2.4-2.7 L · 146-164.8 ci**

**Pro-Copper  
Racing Head Gaskets**

For use with o-rings & sealant

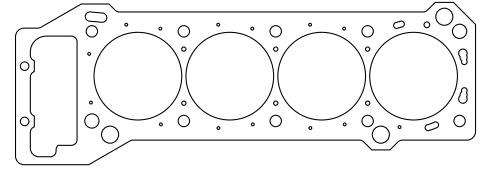

Bore Opening	Thickness								Qty.
	.021"	.032"	.043"	.050"	.062"	.072"	.080"	.093"	
97.8mm round 3.850"	P921421	P921432	P921443	P921450	P921462	P921472	P921480	P921493	1

**Titan  
Copper Racing Head Gaskets**

Sealed coolant passages, for use with o-rings & sealant

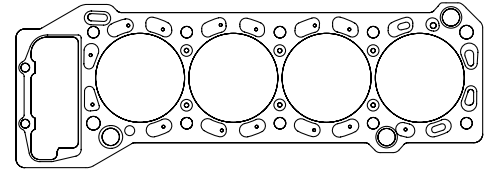

Bore Opening	Thickness								Qty.
	.021"	.032"	.043"	.050"	.062"	.072"	.080"	.093"	
97.8mm round 3.850"	—	T921432	T921443	T921450	T921462	T921472	T921480	T921493	1

**ICS  
Copper Racing Head Gaskets**

Sealed coolant passages, integral combustion o-ring

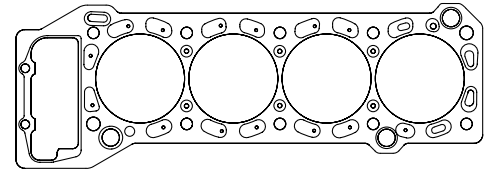

Bore Opening	Thickness								Qty.
	.021"	.032"	.043"	.050"	.062"	.072"	.080"	.093"	
97.8mm round 3.850"	—	—	S921443	S921450	S921462	S921472	S921480	S921493	1

**Toyota · 2AZ-FE DOHC · 2.4 L · 146 ci**

**Pro-Copper  
Racing Head Gaskets**

For use with o-rings & sealant

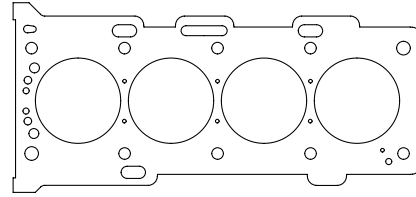

Bore Opening	Thickness								Qty.
	.021"	.032"	.043"	.050"	.062"	.072"	.080"	.093"	
88.9mm round 3.500"	P926321	P926332	P926343	P926350	P926362	P926372	P926380	P926393	1

**Titan  
Copper Racing Head Gaskets**

Sealed coolant passages, for use with o-rings & sealant

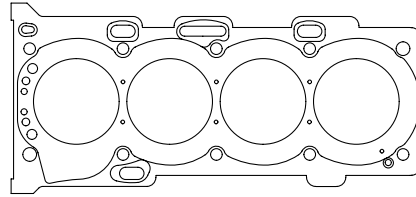

Bore Opening	Thickness								Qty.
	.021"	.032"	.043"	.050"	.062"	.072"	.080"	.093"	
88.9mm round 3.500"	—	T926332	T926343	T926350	T926362	T926372	T926380	T926393	1

**ICS  
Copper Racing Head Gaskets**

Sealed coolant passages, integral combustion o-ring

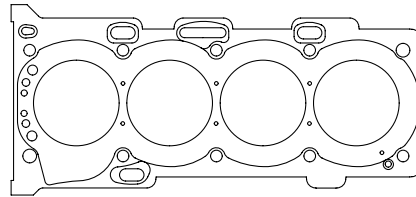

Bore Opening	Thickness								Qty.
	.021"	.032"	.043"	.050"	.062"	.072"	.080"	.093"	
88.9mm round 3.500"	—	—	S926343	S926350	S926362	S926372	S926380	S926393	1

**Toyota · 2JZ-GTE · L6 · 3.0 L · 183.1 ci**

**Pro-Copper  
Racing Head Gaskets**

For use with o-rings & sealant

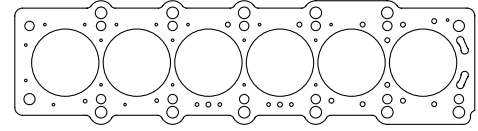

Bore Opening	Thickness								Qty.
	.021"	.032"	.043"	.050"	.062"	.072"	.080"	.093"	
87.3mm round 3.437"	P921121	P921132	P921143	P921150	P921162	P921172	P921180	P921193	1

**Toyota · 1FZ-F/FE · L6 · 4.5 L · 275 ci**

**Pro-Copper  
Racing Head Gaskets**

For use with o-rings & sealant

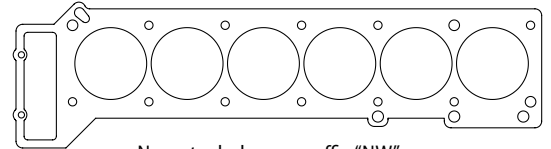
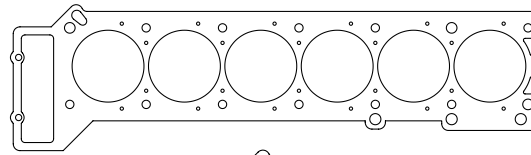

No water holes: use suffix "NW"

Bore Opening	Thickness								Qty.
	.021"	.032"	.043"	.050"	.062"	.072"	.080"	.093"	
101.9mm round 4.010"	P925721	P925732	P925743	P925750	P925762	P925772	P925780	P925793	1

**Titan  
Copper Racing Head Gaskets**

Sealed coolant passages, for use with o-rings & sealant

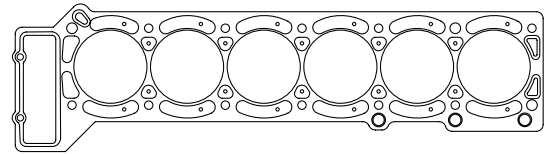

Bore Opening	Thickness								Qty.
	.021"	.032"	.043"	.050"	.062"	.072"	.080"	.093"	
101.9mm round 4.010"	—	T925732	T925743	T925750	T925762	T925772	T925780	T925793	1

**ICS  
Copper Racing Head Gaskets**

Sealed coolant passages, integral combustion o-ring

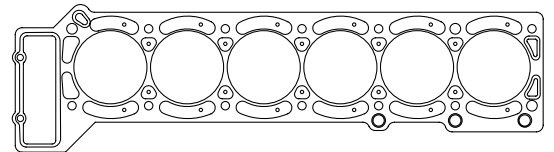

Bore Opening	Thickness								Qty.
	.021"	.032"	.043"	.050"	.062"	.072"	.080"	.093"	
101.9mm round 4.010"	—	—	S925743	S925750	S925762	S925772	S925780	S925793	1

## Volkswagen · Exhaust Gaskets

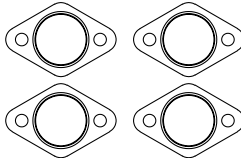
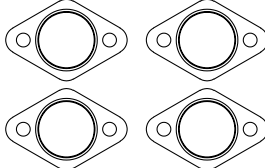
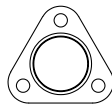
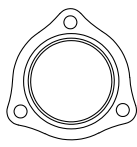
Application — Port Size	Accu-Seal E		Accu-Seal Pro		Pro-Copper	
	Standard Material 1.6 mm / .062"		Premium Material 1.6 mm / .062"		Embossed 1.1 mm / .043"	Flat-Annealed 1.6 mm / .062"
	Packaged 1 Set	Dyno-Pak 10 Sets	Packaged 1 Set	Dyno-Pak 10 Sets	Packaged 1 Set	Packaged 1 Set
<b>1966-80</b> <b>Air-Cooled Flat 4</b> <b>1.6 L · 98 ci</b> — <b>1.50" Round</b>			Fits Air-Cooled Flat 4 engines with stock manifolds or headers. Set contains 4 pieces.			
<b>1966-80</b> <b>Air-Cooled Flat 4</b> <b>1.6 L · 98 ci</b> — <b>1.62" Round</b>			Fits Air Cooled Flat 4 engines with ported heads and large port headers. Set contains 4 pieces			
<b>1966-80</b> <b>Small Collector</b> <b>3-Bolts</b> <b>1.6 L · 98 ci</b> — <b>1.62" Round</b>			Fits Air-Cooled Flat 4 engines. Set contains 1 piece.			
<b>1966-80</b> <b>Large Collector</b> <b>3-Bolts</b> <b>1.6 L</b> <b>98 ci</b> — <b>2.40" Round</b>			Fits Air-Cooled Flat 4 engines, manifold to 'Stinger' or large tube muffler. Set contains 1 piece.			

**Volkswagen · MLS Spartan GS · Performance Head Gaskets**

Application	Image	Bore Opening	Compr. Thickness	Part Number	Description	Qty.
2006-Up CGGA / BSE / BSF / CCSA L4 1.4-1.6 L 85-98 ci		77.8 mm 3.063"	1.0 mm .039"	M338433GS	MLS Spartan with <b>Gas-Stopper</b> embossed stainless steel construction.	1
1978-Up DX / JJ / EX / RH / HV / GX L4 1.8 L 109 ci		81.0 mm 3.189"	1.75 mm .069"	M338461GS		1
1985-Up KR, PL L4 1.8 L 109 ci		83.0 mm 3.268"	1.4 mm .055"	M338003GS		1
		83.8 mm 3.300"	1.4 mm .055"	M338004GS		1
1992-98 VR6 12-Valve AAA / ABV / AES 2.8-2.9 L 170-175 ci		82.5 mm 3.249"	0.65 mm .026"	M338314GS		1
		83.0 mm 3.268"	1.65 mm .065"	M338321GS		
		84.1 mm 3.312"	0.65 mm .026"	M338320GS		
<p><b>Marine Use:</b> stainless steel construction, all MLS Spartan head gaskets are suitable for use in marine applications.</p>						

**Volkswagen · SOHC · 8V · 1.8 L · 110 ci**

**Pro-Copper  
Racing Head Gaskets**

For use with o-rings & sealant

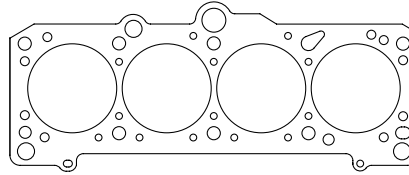

Bore Opening	Thickness								Qty.
	.021"	.032"	.043"	.050"	.062"	.072"	.080"	.093"	
84 mm round 3.305"	P919821	P919832	P919843	P919850	P919862	P919872	P919880	P919893	1

**Volkswagen · Turbo · DOHC · 16V · 1.8 L · 110 ci**

**Pro-Copper  
Racing Head Gaskets**

For use with o-rings & sealant

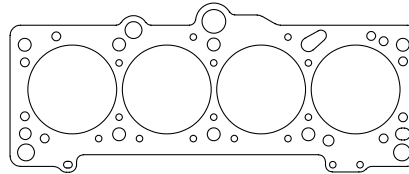

Bore Opening	Thickness								Qty.
	.021"	.032"	.043"	.050"	.062"	.072"	.080"	.093"	
84 mm round 3.305"	P919921	P919932	P919943	P919950	P919962	P919972	P919980	P919993	1

**Volkswagen · SOHC · 8V · 2.0 L · 122 ci**

**Pro-Copper  
Racing Head Gaskets**

For use with o-rings & sealant

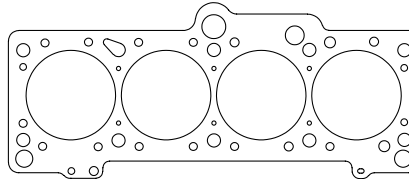

Bore Opening	Thickness								Qty.
	.021"	.032"	.043"	.050"	.062"	.072"	.080"	.093"	
82.8 mm round 3.260"	P920121	P920132	P920143	P920150	P920162	P920172	P920180	P920193	1

**Volkswagen · VR6 · 12V · 2.8-2.9 L · 171-177 ci**

***Pro-Copper***  
***Racing Head Gaskets***

For use with o-rings & sealant

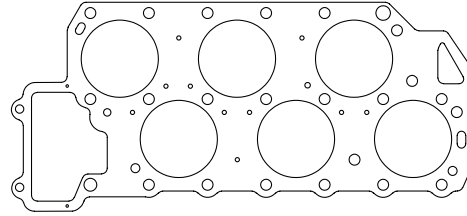

Bore Opening	Thickness								Qty.
	.021"	.032"	.043"	.050"	.062"	.072"	.080"	.093"	
84 mm round 3.305"	-	P920232	P920243	P920250	P920262	P920272	P920280	P920293	1

**Volkswagen · VR6 · 24V · 2.8-3.2 L · 171-195 ci**

***Pro-Copper***  
***Racing Head Gaskets***

For use with o-rings & sealant

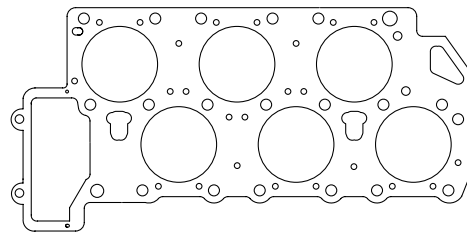

Bore Opening	Thickness								Qty.
	.021"	.032"	.043"	.050"	.062"	.072"	.080"	.093"	
84 mm round 3.305"	-	P924732	P924743	P924750	P924762	P924772	P924780	P924793	1

**Roots Type · Blower Gaskets**

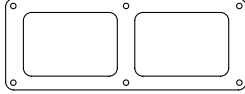
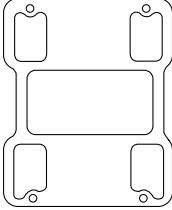
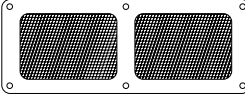
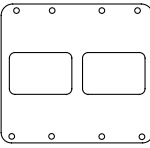
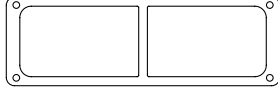
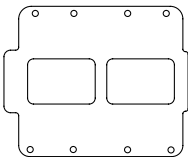
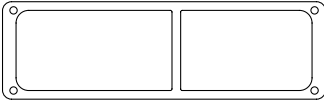
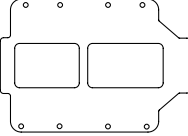
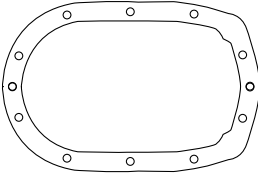
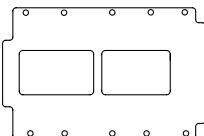
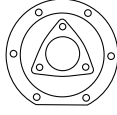
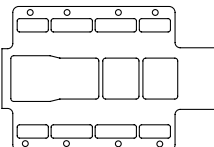
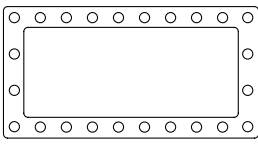
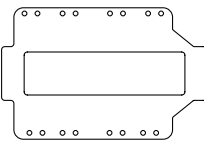
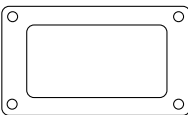
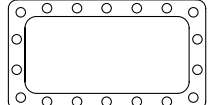
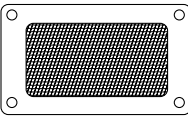
Description	Part Number	Image	Description	Part Number	Image
Blower Manifold End Seals - Chrysler 426 Race Hemi	26601 2 pc		6-71 / 8-71 Inlet Gasket	329100 1 pc	
4-71 Base Gasket	329010 1 pc		6-71 / 8-71 Screened Inlet Gasket	329120 1 pc	
6-71 Base Gasket	329020 1 pc		14-71 Inlet Gasket	329140 1 pc	
8-71 Base Gasket	329030 1 pc		14-71 X-Large Inlet Gasket	329160 1 pc	
14-71 8-Bolt Base Gasket	329041 1 pc		Front Cover Gasket	329200 1 pc	
14-71 10-Bolt Base Gasket	329040 1 pc		Snout Gasket	329300 1 ea	
14-71 Kobelco Base Gasket	329042 1 pc		<b>NEW</b> Burst Panel Gasket - Large	329170 2 pc	
14-71 SSI Base Gasket	329043 1 pc			329170-10 Dyno-Pak 10 pc	
4-71 Inlet Gasket	329060 1 pc		<b>NEW</b> Burst Panel Gasket - Small	329171 2 pc	
4-71 Screened Inlet Gasket	329080 1 pc			329171-10 Dyno-Pak 10 pc	



**Standard Coated Gaskets · Holley® Style Carburetors**

Description	Part Number	Image	Pkg. Qty.	Description	Part Number	Image	Qty.
2300, 4150, 4160 Fuel Bowl	358		2 pc	4160 & 4175 Vacuum Secondary Metering Block	361		2 pc
4500 Series Fuel Bowl	359		2 pc	4150-4500 Series 2-Circuit Metering Block	370		2 pc
4500 Series 3-Circuit Metering Block	372		2 pc	4150-4160 Carb Bowl & 2-Circuit Metering Block	346		2 pc

**Other Fuel System Gaskets**

Description	Part Number	Image	Qty.	Description	Part Number	Image	Qty.
5" I.D. Air Cleaner Mounting Gasket	201		Dyno-Pak 10 pc	Fuel Cell Fill Neck Gasket	206		1 pc
Fuel Cell Vent Tube Gasket	205		1 pc	24 Bolt Fuel Cell Fill Plate Gasket	207		1 pc

**Carburetor Base - Mounting Gaskets**

Description	Part Number	Image	Qty.	Description	Part Number	Image	Qty.
Split Dominator	347-1		1 pc	Holley® 4bbl 4-Hole 1.680"	355-2		1 pc
	347		Dyno-Pak 10 pc		-		-
Holley® 4bbl Insulator Gasket 1.625" x .250"	352		1 pc	Holley® 4bbl 4-Hole 1.740"	355-1		1 pc
	-		-		355		Dyno-Pak 10 pc
Holley® 500 CFM 2bbl	349-1		1 pc	Rochester Quadrajct Spreadbore	356-1		1 pc
	349		Dyno-Pak 10 pc		356		Dyno-Pak 10 pc
Holley® 350 CFM 2bbl	350-1		1 pc	Rochester Quadrajct Insulator Gasket .250" Thick	357		1 pc
	350		Dyno-Pak 10 pc		-		-
Holley® 2bbl NASCAR Spec Restrictor Plate	351-1		1 pc	Holley® Dominator 4-Hole 2.060"	3582-1		1 pc
	-		-		3582		Dyno-Pak 10 pc
Holley® 4bbl Open	354-1		1 pc	Holley® Dominator Open	3583-1		1 pc
	354		Dyno-Pak 10 pc		3583		Dyno-Pak 10 pc
				Holley® Spreadbore	3584-1		1 pc
					3584		Dyno-Pak 10 pc

**Throttle Body · Mounting Gaskets**

Description	Part Number	Image	Qty.	Description	Part Number	Image	Qty.
AMC / Jeep 2.5 L · 87-95 4.0 L · 91-99	208		1 pc	Ford 5.0 L / 1988-93 Mustang	221		1 pc
Chrysler PT Cruiser 2.0 L	233		1 pc	Ford 5.0 L / 1994-95 Mustang	222		1 pc
Dodge Neon 2.0 L	235		1 pc	GM 2.0-2.4 L	231		1 pc
Dodge 3.9 L · 5.9 L V8 · 1992-00	212		1 pc	GM 4.8-8.1 L	214		1 pc
Dodge V10 · 1994- 01 / Ford V10 · 1999-01	209		1 pc	GM 305-350 ci V-8 1985-92	217		1 pc
Dodge V-10 · 1994-02	219		1 pc	Honda 1.5-1.6 L Civic	234		1 pc
Ford Mustang 3.8 L V6 1994-96	210		1 pc	Honda 1.7 L 2001-05 Civic	230		1 pc
Ford Mustang 3.8 L · 99-01 4.2 L · 97-01	213		1 pc	Mitsubishi Eclipse 1.8-2.4 L	229		1 pc
Ford Expedition F-150 4.6-5.4 L 1997-01	211		1 pc	Saturn SL2 1.9 L	224		1 pc
Ford 5.0 L 1986-93	220		1 pc	Toyota 3.4 L 1998-02	218		1 pc

**Collector & Turbo · Flange Gaskets**

<b>Description</b>	<b>Image</b>	<b>Accu-Seal E</b>	<b>Accu-Seal Pro</b>	<b>Pro-Copper</b>	<b>Qty.</b>
1.5" 2-Bolt Flange		-	-	4150	1 pc
1.75" 2-Bolt Flange		-	-	4175	1 pc
2.00" 2-Bolt Flange		-	-	4202	1 pc
2.00" 3-Bolt Flange		-	-	4203	1 pc
2.25" 2-Bolt Flange		-	-	4225	1 pc
2.25" 3-Bolt Flange		-	-	4220	1 pc
2.50" 2-Bolt Flange		-	-	4200	1 pc
2.50" 3-Bolt Header Collector		575999	576002	4250	1 pc
3.0" 3-Bolt Header Collector		512039	512042	4300	1 pc
3.5" 3-Bolt Header Collector		512029	512032	4350	1 pc

**Collector & Turbo · Flange Gaskets**

Description	Image	Accu-Seal E	<i>Accu-Seal Pro</i>	<i>Pro-Copper</i>	Qty.
3.75" Square Street Performance Brand Collector Gaskets		514375	514377	4375	1 pc
4.0" 4-Bolt Collector Gaskets		-	-	4404	1 pc
3-Bolt, 2-Port Import Collector/Down Pipe		516500	516502	9400	1 pc
T2 Flange Gasket		-	-	9456	1 pc
T25/T28 Turbine Outlet Gasket		-	-	9461	1 pc
T3 Round Flange Gasket		-	-	9429	1 pc
T3 Symmetrical Flange Gasket		-	-	9453	1 pc
T3/T4 Rectangle Flange Gasket		-	-	9428	1 pc
T4 Flange Gasket		-	-	9452	1 pc
90mm Turbo Flange Gasket		-	-	9466	1 pc

## Rear Axle Gaskets

Description	Image	Accu-Seal E	<i>Accu-Seal Pro</i>	Qty.
		Standard Material	Re-usable Steel-Core PTFE-Coated	
<b>Contoured Quick Change Gasket</b>		104	204	1 pc
<b>Ford 8.8" Gasket</b>		181	281	1 pc
<b>Ford 9" Gearset Gasket</b>		182	282	1 pc
<b>GM 10-Bolt Gasket 8.20" ring gear</b>		183	283	1 pc
<b>GM Car 12-Bolt Gasket 8.875" gear</b>		184	284	1 pc
<b>Dana 44 Gasket</b>		185	285	1 pc
<b>Dana 50-60-70 Gasket</b>		186	286	1 pc
<b>GM Gasket 10.5" Ring Gear</b>		187	287	1 pc

**Accessories · O-ring Wire & Sealants**

Description	Part Number	Image	Description	Part Number	Image
.041" 304 Stainless O-ring Wire: 15' roll for 10 cylinders	31541		<b>NEW</b> Athesil Gray Silicone: 2.7 oz · 80 ml Tube  Includes applicator tip & tube squeeze key	G1613  G1613-12 Master-Pak 12 pc	
.062" 304 Stainless O-ring Wire: 15' roll for 10 cylinders	31562		Gasgacinch Gasket Sealing Compound: 8oz Brush Top Can	G1614	
.041" 304 Stainless O-ring Wire & Kit: 15' of wire, tool & instructions	31542		Gasgacinch Gasket Sealing Compound: 16oz Brush Top Can	G1616	
.062" 304 Stainless O-ring Wire & Kit: 15' of wire, tool & instructions	31563		<b>NEW</b> Chevrolet Copper Distributor Base Gasket: SBC/BBC All	202C 1 pc	
.041" 304 Stainless O-ring Wire: 1 Pound Spool	31543			202C-10 Dyno-Pak 10 pc	
Copper Coat Head Gasket Sealant Aerosol 9oz	G1612				



# SCE · PART NUMBER LEGEND

<b>STYLE CODE:</b> CR = Vulcan Cut-Ring M = MLS Spartan <b>P</b> = Pro-Copper S = ICS T = Titan 5 = Accu-Seal Pro	<b>ENGINE CODE:</b> <i>Domestic-Only</i> <b>13</b> = Big Block Chevrolet	<b>BORE:</b> <i>Domestic-Only</i> <b>52</b> = 4.520"	<b>THICKNESS:</b> <i>Domestic-Only</i> <b>43</b> = .043"
P	13	52	43

## **Unit Terminology Guide**

<b>Each</b> = 1 unit of sale • Ea. ea.
<b>Piece</b> = a single part piece • Pc. Pcs. pc. pcs.
<b>Set</b> = multiple pieces, 1 part number
<b>Kit</b> = packaged as a "kit", has its own part number, but contains multiple part numbers
<b>Dyno-Pak</b> = 10 sets • "-10" suffix
<b>Hundred-Pak</b> = 100 sets • "B" suffix
<b>Master-Pak</b> = 12 pc. (Athesil) • "-12" suffix



# Recommended Applications for Various Head Gaskets

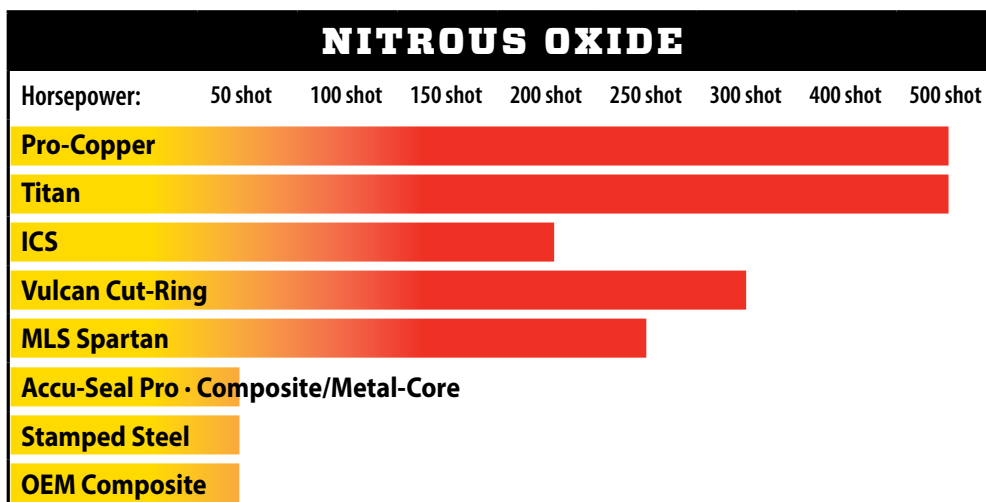
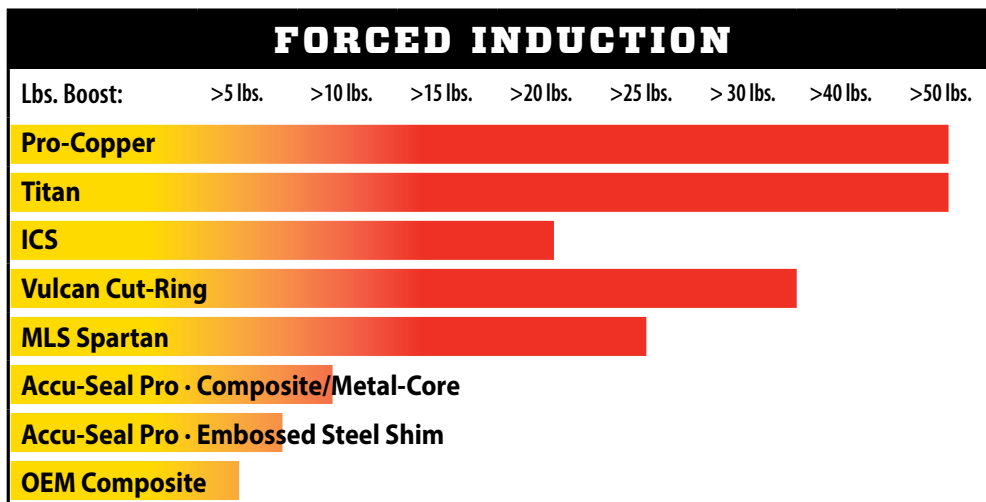
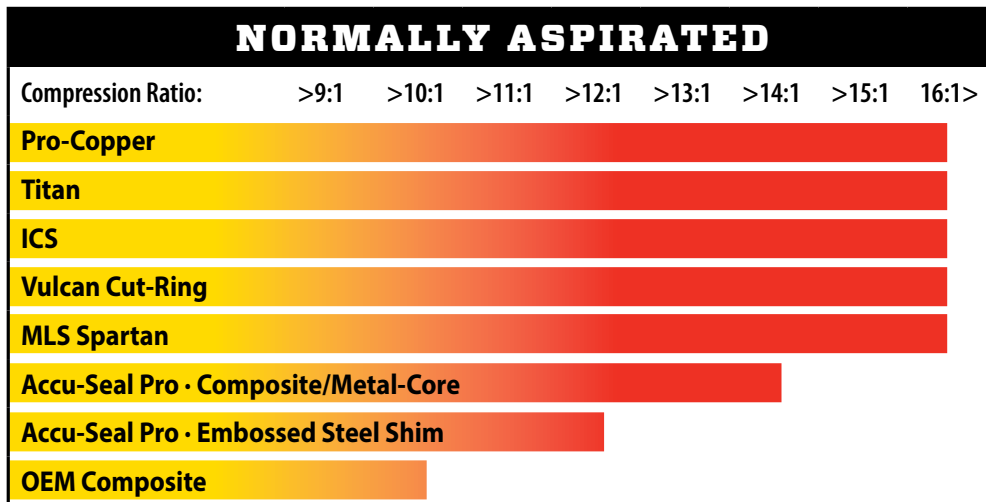

*Nitrous oxide* numbers are  $N_2O$  alone & not with other power adders. | **Note:** This bar chart is a general guide to head gasket selection based on typical combustion pressures in engines with these modifications. Given the wide range of factors that affect gasket performance such as, camshaft design, ignition timing, fuel type, number of head bolts, etc., suitability for use is the responsibility of the engine builder or end user.

# General Head Gasket Installation Instructions

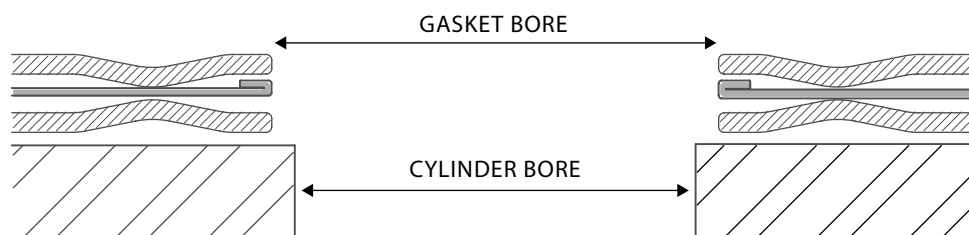

**Note:** When choosing a head gasket, we strongly recommend selecting a gasket bore diameter **.020"-.050"** larger than the cylinder bore opening. Image depicts Gas-Stopper design (MLS GS) head gasket.

## STEPS

1. Thoroughly clean and degrease block and cylinder head sealing surfaces.
2. Inspect block and head sealing surfaces for flatness, surface finish, gouging or corroded areas.
3. Maximum warpage:
  - a. .002" across shortest section.
4. Surface Finish Recommendations in Ra (roughness average):
  - a. Copper head gaskets, <80 Ra.
  - b. Composite head gaskets, <80 Ra.
  - c. Steel Shim head gaskets, <60 Ra.
  - d. Vulcan Cut-Ring head gaskets, <60 Ra.
  - e. MLS Spartan head gaskets, <50 Ra.
5. Chase engine head bolt / stud hole threads with a thread tap, threads must be clean for accurate torque readings. Unclean threads may result in gasket failure.
6. Inspect new head gasket to ensure no damage occurred during shipping. Gasket should be flat and smooth, coatings (where applicable) should be uniform and devoid of scratches or scuffs.
7. Use care in handling, head gaskets can easily be scratched by careless handling around unassembled engine components.
8. Check for proper fitment and clearance by placing the head gasket on the cylinder head sealing surface in the properly aligned installed position.
  - a. Head gasket combustion seal must have 360° contact around combustion chamber.
  - b. Gasket bore opening or valve reliefs must be outside of valves -through their full range of motion.
9. Use sealant only where specified by instructions related to the gasket type being installed (see specific instruction sheets for Pro-Copper, Titan, ICS, Vulcan Cut-Ring, and MLS Spartan head gaskets). Excessive use of sealants will negatively affect sealing at cylinder bores.
10. Install head gasket on block sealing surface. **Important: make sure each head gasket is properly positioned regarding coolant, oil pressure and oil drain passages.**
11. Use new fasteners and lubricate (moly lube is preferred) threads, underside of bolt heads, nuts and upper side of washers.
12. Torque specifications and sequence; follow cylinder block and fastener manufacturer recommendations. Failure to do so may prevent fasteners from reaching correct preload leading to gasket failure.
13. Start engine and allow it to reach operating temperature. Check for engine leaks (fluid or vacuum). If there is a leak, stop the engine, let it cool and find/fix cause of leak.
14. Re-Torque head bolts (engine cold) according to block manufacturer instructions; not required but always suggested on racing engines.

*Instructions can also be found at [SCEgaskets.com/instructions](http://SCEgaskets.com/instructions)*

## Compression Ratio Formula

Compression Ratio (CR) is defined as the quantitative relation between the total volume above the piston at BDC, and the clearance volume above the piston at TDC. To determine compression ratio you need to know:

- 1. Cylinder volume (V)** or cylinder displacement, determined by cylinder bore and stroke (indicated by movement of piston from BDC to TDC).

Cylinder volume formula (in cubic inches):  $Bore \times Bore \times Stroke \times .7854$

- 2. Clearance Volume (V<sub>CL</sub>)** is the volume above the piston (actually above the top piston ring) at TDC. It consists of several small volumes which are measured in cubic centimeters, or CCs, as follows:

**Deck Clearance Volume** formula:

$Bore \times Bore \times Depth \text{ of Piston @ TDC} \times 12.87$

**Gasket Volume** formula:

$Bore \text{ of Gasket} \times Bore \text{ of Gasket} \times Thickness \times 12.87$

(or refer to the chart below)

**Valve Notch Volume:** Available from your piston MFG, or must be CC'd using a burette. This figure must be **added** to clearance volume.

**Piston Dome Volume:** Available from your piston MFG, or must be CC'd using a burette. This figure must be **subtracted** from clearance volume.

**Combustion Chamber Volume:** Available from your cylinder head MFG, or must be CC'd using a burette.

- 3. Convert Total Clearance Volume** from CCs to cubic inches, **multiply** by .06102.

- 4. Add the two volumes together (V + V<sub>CL</sub>), then divide** by V<sub>CL</sub>.

The formula is:  $CR = V + V_{CL} / V_{CL}$

### GASKET VOLUME CHART (in CCs)

GASKET BORE	GASKET THICKNESS							
	.021	.032	.043	.050	.062	.072	.080	.093
3.000	2.432	3.706	4.980	5.791	7.181	8.339	9.266	10.772
3.080	2.563	3.906	5.249	6.104	7.569	8.790	9.767	11.354
3.150	2.681	4.086	5.491	6.385	7.917	9.194	10.216	11.876
3.250	2.854	4.350	5.845	6.796	8.428	9.787	10.875	12.642
3.260	2.872	4.376	5.881	6.838	8.480	9.847	10.942	12.720
3.305	2.952	4.498	6.044	7.028	8.715	10.121	11.246	13.073
3.375	3.078	4.691	6.303	7.329	9.089	10.555	11.727	13.633
3.437	3.192	4.865	6.537	7.601	9.426	10.946	12.162	14.139
3.500	3.310	5.045	6.779	7.882	9.774	11.351	12.612	14.662
3.625	3.551	5.411	7.272	8.455	10.485	12.176	13.529	15.728
3.670	3.640	5.547	7.453	8.667	10.747	12.480	13.867	16.121
3.750	3.800	5.791	7.782	9.049	11.221	13.030	14.478	16.831
3.850	4.006	6.104	8.202	9.538	11.827	13.735	15.261	17.741
3.950	4.216	6.465	8.635	10.040	12.450	14.458	16.064	18.674
4.010	4.345	6.622	8.898	10.347	12.830	14.900	16.556	19.246
4.060	4.455	6.788	9.122	10.607	13.152	15.274	16.971	19.729
4.155	4.665	7.110	9.554	11.109	13.775	15.997	17.775	20.663
4.200	4.767	7.264	9.762	11.351	14.075	16.345	18.162	21.113
4.250	4.881	7.438	9.995	11.623	14.412	16.737	18.597	21.619
4.320	5.043	7.685	10.327	12.009	14.891	17.293	19.214	22.337
4.380	5.184	7.900	10.616	12.345	15.308	17.777	19.752	22.962
4.440	5.327	8.118	10.909	12.685	15.730	18.267	20.297	23.595
4.520	5.521	8.414	11.306	13.146	16.302	18.931	21.035	24.453
4.570	5.644	8.601	11.557	13.439	16.664	19.352	21.503	24.997
4.620	5.768	8.790	11.812	13.735	17.031	19.776	21.976	25.547

# Vulcan Cut-Ring™ Head Gaskets

## Hybrid Stainless Steel & Composite

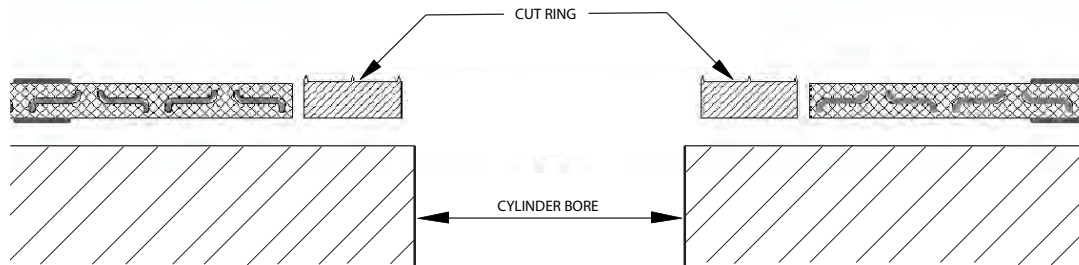

## INSTALLATION INSTRUCTIONS

**Note:** Head gasket bore opening should always be larger than the cylinder bore opening.

### STEPS

1. Thoroughly clean and degrease block and cylinder head sealing surfaces.
2. Inspect head and block surfaces.
3. Maximum allowable warpage: .002" across shortest section.
4. Finish Recommendation: 30-80 Ra (roughness average).
5. Gouging: Aluminum surfaces must be free of deep scratches, gouges, or depressions
6. Chase engine block threads with a thread tap, threads must be clean for accurate torque readings. Unclean threads may result in gasket failure.
7. Inspect new head gasket to insure no damage in shipping. Polymer sealant coating should be uniform over gasket body surface without scratches or scuffs. Stainless steel cut rings should be circular, lay flat without bends or scratches.
8. Use care in handling; Vulcan Cut-Ring head gaskets have a proprietary sealant coating that can be damaged by excess handling. Stainless steel cut rings have a top (grooved) side and bottom (flat smooth) side, be sure not to damage grooves on top side of Cut-Ring.
9. Use no sealant; additional sealant will negatively affect sealing performance of head gasket body and Cut- Rings.
10. Use new fasteners and lubricate (moly lube is preferred) threads, underside of bolt heads, nuts, and upper side of washers.
  - a. Install composite head gasket body onto engine block using dowel rings to locate head gasket correctly. **Important: make sure each head gasket is properly positioned regarding coolant, oil pressure and oil drain passages.**
  - b. Install Cut-Rings by simply placing into the bore openings of the gasket body -**USE NO ADHESIVE**-

Cut-Rings are to be installed with  
**RIDGES UP – FLAT SIDE DOWN** as illustrated above.
11. Torque specifications and sequence; follow cylinder block and fastener manufacturer recommendations. Failure to do so may prevent fasteners from reaching correct preload leading to gasket failure.
12. Start engine and allow it to reach operating temperature. Check for engine leaks (fluid or vacuum). If there is a leak, stop the engine, let it cool and find/fix cause of leak.
13. Re-Torque head bolts (engine cold) according to block manufacturer instructions; not required but always suggested on racing engines.

*Instructions can also be found at [SCEgaskets.com/instructions](http://SCEgaskets.com/instructions)*

# MLS Spartan™ Head Gaskets

## Multi-Layer Stainless Steel

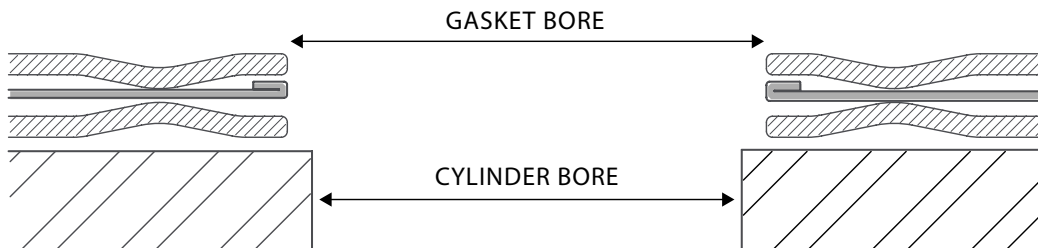

**Note:** Head gasket bore opening should always be larger than the cylinder bore opening. Image depicts Gas Stopper design (MLS GS) head gasket.

## INSTALLATION INSTRUCTIONS

### STEPS:

1. Thoroughly clean and degrease block and cylinder head sealing surfaces.
2. Inspect block and head sealing surfaces for:
  - a. Maximum warpage: .002" across shortest section.
  - b. Surface Finish Recommendation: 30-60 Ra (roughness average).
  - c. Gouging: Aluminum surfaces must be free of deep scratches, gouges, or depressions.
3. Chase engine block threads with a thread tap -threads must be clean for accurate torque readings. Unclean threads may result in gasket failure.
4. Inspect new head gasket to insure no damage in shipping. Polymer sealant coating should be uniform and devoid of scratches or scuffs.
5. Use care in handling; SCE Gaskets MLS Spartan and MLS Spartan with Gas-Stopper have a proprietary two-part sealant coating: second coating can be damaged by excess handling.
6. Use no sealant; additional sealant will negatively affect sealing at cylinder bores.
7. Install head gasket on block sealing surface. **Important: make sure each head gasket is properly positioned regarding coolant, oil pressure and oil drain passages.**
8. Use new fasteners and lubricate (moly lube is preferred) threads, underside of bolt heads, nuts, and upper side of washers.
9. Torque specifications and sequence; follow cylinder clock and fastener manufacturer recommendations. Failure to do so may prevent fasteners from reaching correct preload leading to gasket failure.
10. Start engine and allow it to reach operating temperature. Check for engine leaks (fluid or vacuum). If there is a leak, stop the engine, let it cool and find/fix cause of leak.
11. Re-Torque head bolts (engine cold) according to block manufacturer instructions; not required but always suggested on racing engines.

**MLS Spartan Gas-Stopper** (MLS GS) technology offers enhanced multilayer head gasket combustion sealing where required. A stainless-steel Gas-Stopper layer is folded onto itself around the cylinder bore aperture to provide additional clamp load on the combustion seal for high cylinder pressure (power adder) applications.

*Instructions can also be found at [SCEgaskets.com/instructions](http://SCEgaskets.com/instructions)*

# ***Accu-Seal Pro™***

## ***Composite/Metal-Core Head Gaskets***

**Recommended uses:** Stock Replacement to Mild Race with Mild Boost or Nitrous

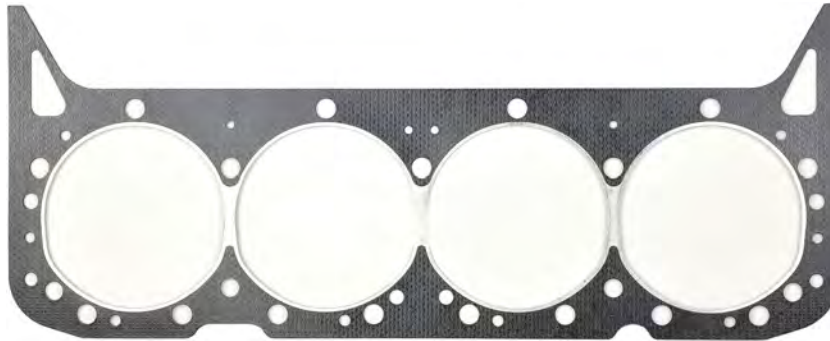

### **INSTALLATION INSTRUCTIONS**

#### **STEPS:**

- 1.** Before installing the gasket perform a visual check to ensure that no damage occurred during shipping. The gasket(s) should be flat and free of dents or scratches.
- 2.** Certain head gaskets are oriented right / left, and or front / rear. In these cases, the head gaskets will be marked accordingly. It is imperative that oriented head gaskets are installed in the correct position.
- 3.** Good engine building practice requires clean, flat surfaces, and clean fastener threads. Use a solvent degreaser to remove oil from block & head. If fastener threads are tapped through the deck, use care in sealing the threads with a quality sealant to prevent coolant migration up the threads.
- 4.** Quality fasteners are critical to the success of your project. OEM style head bolts are acceptable if they are new. When using studs, make sure there is adequate thread length so that nuts do not “bottom out”. Always use thread lubricant and high quality,

hardened washers. SCE Gaskets recommends following engine manufacturer torque sequence and torque values.

- 5.** If used in a performance application, SCE strongly recommends that head bolts/studs be re-torqued after initial start-up.
  - a.** Start the engine and allow it to reach operating temperature with no load.
  - b.** Shut down and allow the engine to cool to ambient temperature.
  - c.** With the engine cold and following the recommended torque sequence, one at a time, loosen each fastener just enough to relieve the friction set.
  - d.** Finally, re-torque to specified torque value.

*Instructions can also be found at [SCEgaskets.com/instructions](http://SCEgaskets.com/instructions)*



# **Accu-Seal Pro™**

## **Embossed Steel Shim Head Gaskets**

**Recommended uses:** To Increase Compression Ratio on Stock Replacement to Mild Race Engines with Mild Boost or Nitrous.



### **INSTALLATION INSTRUCTIONS**

**Note:** Do not use with O-Rings. Additional Sealant is Required (see step 4 below).

#### **STEPS:**

**1.** Before installing the gasket perform a visual check to ensure that no damage occurred during shipping. The gasket(s) should be flat and free of dents or scratches.

**2.** Good engine building practice requires clean, flat surfaces and clean head bolt / stud threads. Use a solvent degreaser to remove oil from block & head. If fastener threads are tapped through the deck, use care in sealing the threads with a quality sealant (SCE p/n G1615) to prevent coolant migration up the threads.

**3.** Quality fasteners are critical to the success of your project. OEM style head bolts are fine if they are new. When using studs make sure there is adequate thread length so that nuts do not "bottom out". Since these shim gaskets are thinner than most, double check to make sure the registers for locating dowels or ring dowels are of sufficient depth that the dowel will not bottom out and hold the cylinder head off the gasket/block deck. Always use thread lubricant and good quality hardened washers. Follow engine manufacturer torque sequence and values.

**4.** Embossed Steel and Copper head gaskets require use of additional sealant for coolant and oil passages. -Do Not Use Silicone- Only those sealants designed for use on head gaskets should be used. Suitable head gasket dressings are; Copper Coat Spray (SCE p/n G1612), Hylomar Aerograde or Permatex High Tack. SCE recommends Copper Coat because it is dependable, easy to find & easy to use. Apply **a light coat** on both sides of the head gaskets and let them hang for a couple of hours, then install.

**5.** If used in a performance application, SCE strongly recommends that head bolts/studs be re-torqued. Start the engine and allow it to reach operating temperature with no load. Shut down and allow the engine to cool to ambient temperature. With the engine cold and following the recommended torque sequence, one at a time, loosen each fastener just enough to relieve the friction set, then re-torque to the engine manufacturer specified torque value.

**Instructions can also be found at [SCEgaskets.com/instructions](http://SCEgaskets.com/instructions)**



# ICS™ Copper Head Gaskets

## Integral Combustion Seal

**Pro-Copper + bead seals + o-rings • No O-rings needed** in block or cylinder head.

**Recommended uses:** High Performance Street, Mild Race, with Medium Boost or Nitrous.

### INSURE 360° CONTACT

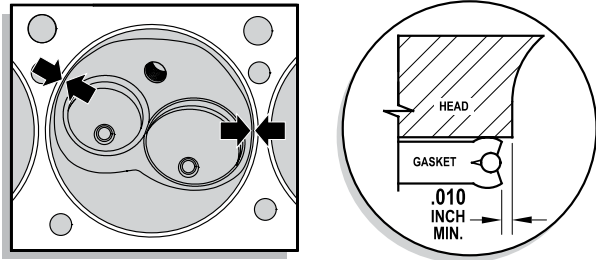

### CORRECT

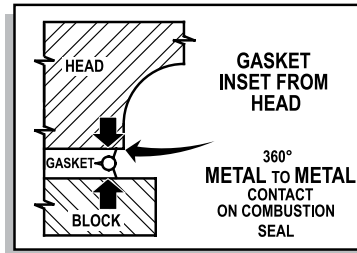

### INCORRECT

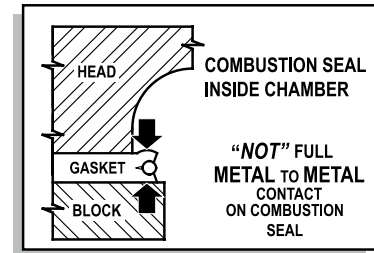

## INSTALLATION INSTRUCTIONS

**Note:** Ensure 360° Contact. Do not use O-rings. Sealant (such as Copper Coat, SCE p/n G1612) may be used if desired.

### STEPS:

1. Before installing head gasket, visually inspect for shipment damage. Sealant beads must be continuous without gaps or scratches and the wire should not protrude out from combustion seal.
2. Gasket to head check, place cylinder head on a bench flat side up. Align new gasket on head in the assembled location, check to insure 360° metal to metal contact on combustion seal paying close attention to valve reliefs, see illustrations above.
3. Check head and block mating surfaces to ensure flatness within .002" using a steel straight edge and thickness gauge. If a sealing surface exceeds .002" out of flat, have the component resurfaced to an 80ra finish or finer.
4. New head studs/bolts are recommended for proper gasket sealing, threads must be in good condition otherwise replace. Use a tap to clean threads in block. If threads are tapped through the deck, use care in sealing threads to prevent coolant migration

up the bolt. If studs are to be used check for proper length so nuts do not "bottom out". Always use quality hardened washers and thread lubricant to prevent thread galling.

5. Sealant is not required but may be used if desired (Copper Coat p/n G1612). Position new gasket over locating dowels on block. Position cylinder head over dowel pins without disturbing gasket, Tighten bolts and torque in sequence per manufacturers' specifications.
6. ICS head gaskets must be re-torqued. Start the engine and allow it to reach operating temperature without placing any load on the engine. Shut down and allow the engine to return to ambient temperature. With the engine cold and following the recommended torque sequence, one at a time back each fastener off just enough to relieve the friction set, then re-torque to specified torque value

*Instructions can also be found at [SCEgaskets.com/instructions](http://SCEgaskets.com/instructions)*



# Titan™ Copper Head Gaskets

**Pro-Copper + bead seals • O-rings required** in block or cylinder head.

**Recommended uses:** Racing Engines with Heavy Boost or Nitrous running liquid coolant.

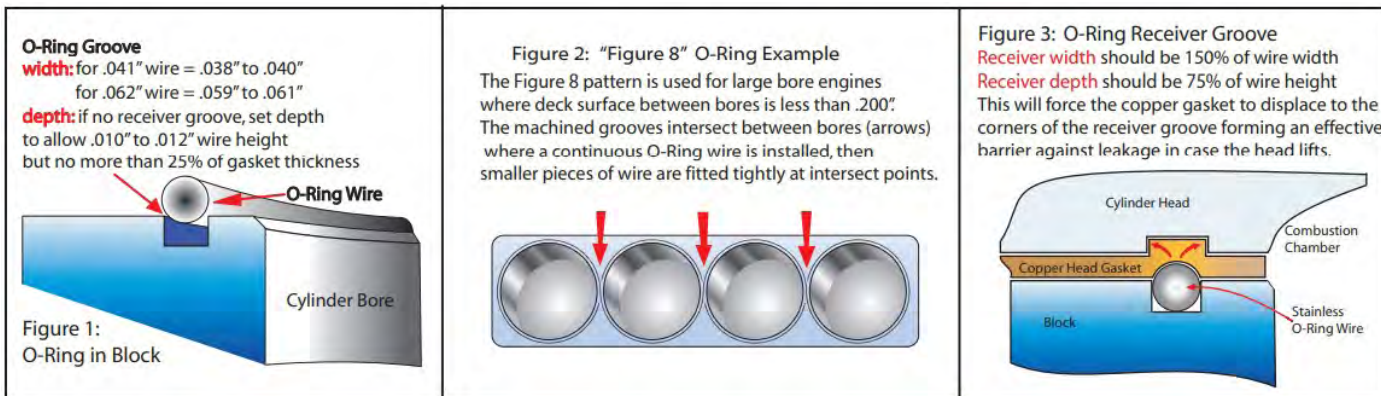

## INSTALLATION INSTRUCTIONS

**Note:** O-rings are required in the block or head, Sealant may be used if desired (Copper Coat, SCE p/n G1612).

### STEPS:

- Before installing head gasket, visually inspect for shipment damage. Sealant beads must be continuous without gaps or scratches.
- Titan series head gaskets ("T" Prefix) require o-ring combustion seals installed in the head or block. (p/n 31542 o-ring kit) Great care has been taken to allow as much room as possible for o-ring placement, if your o-rings are already in the head or block check to see that the sealant beads are clear of the o-ring.
- When installing o-rings there are two main considerations for placement.
  - The o-ring must be clear of the sealant beads on the gasket. This will determine the maximum outer diameter of the o-ring.
  - The o-ring diameter and location must accommodate bore opening and combustion chamber size and shape this will determine the minimum inside diameter of the o-ring.
- Recommended o-ring protrusion is not more than 25% of gasket thickness (SEE FIGURE 1). Example: Gasket thickness .043", o-ring protrusion height is .008" to .010". This standard works with all thicknesses that are .050" and less. Gaskets that are thicker than .050" do not require o-ring height more than .012". NOTE: For extreme boost or heavy nitrous an O-ring-Receiver-Groove arrangement is recommended (SEE FIGURE 3). When using a receiver-groove the wire may be higher than 25%

of gasket thickness; wire height & width determines receiver groove depth & width by maintaining the relationships in the Figure 3 illustration.

- If the combustion chamber or bore is so large that the o-rings will be placed less than .100" apart between cylinders, it is advisable to use a "figure 8" pattern for o-rings (SEE FIGURE 2 BELOW). This allows for more even clamp load over the entire head surface.
- New head studs/bolts are recommended for proper gasket sealing. Threads must be in good condition otherwise replace, a die can be used to remove old sealant and/or rust. Use a tap to clean threads in block. If threads are tapped through the deck, use care in sealing threads to prevent coolant migration up the bolt. If studs are to be used check for proper length so nuts do not "bottom out". Always use quality hardened washers and thread lubricant to prevent thread galling.
- As with any performance application it is strongly recommended that head bolts/studs be re-torqued. Start the engine and allow it to reach operating temperature without placing any load on the motor. Shut down and allow the motor to cool to ambient temperature. With the engine cold and following the recommended torque sequence, one at a time back each fastener off just enough to relieve the friction set, then re-torque to specified torque value.

*Instructions can also be found at [SCEgaskets.com/instructions](http://SCEgaskets.com/instructions)*

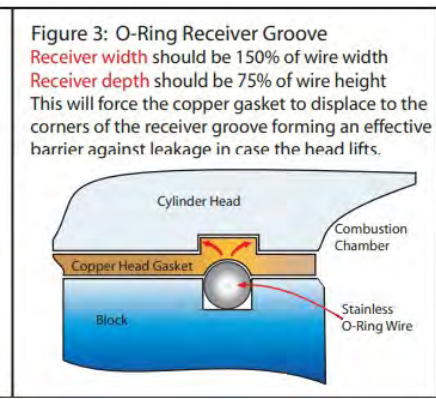
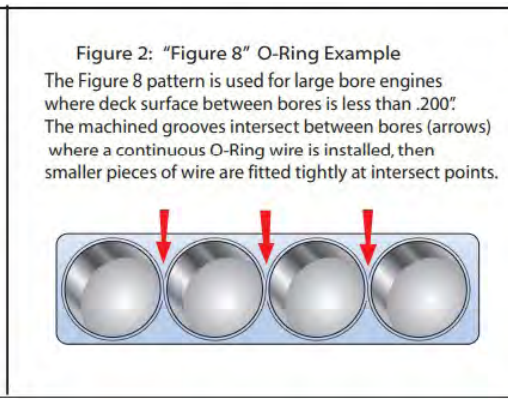
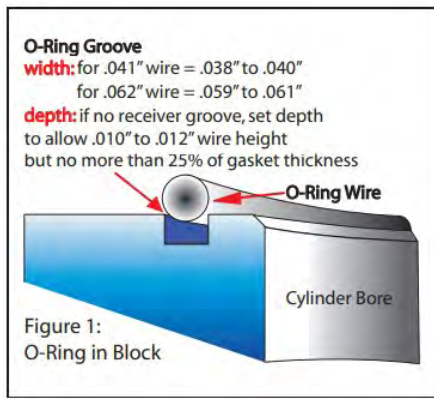

# Pro-Copper™ Head Gaskets

**O-rings required** in block or cylinder head.

## INSTALLATION INSTRUCTIONS

**Note:** For best results SCE Pro-Copper Series (P prefix) Copper Head Gaskets should be used with sealant (if liquid cooled use Copper Coat, SCE p/n G1612) and o-ringed block or heads.

### STEPS:

1. Before installing the gasket, perform a visual check to ensure that no damage occurred during shipping, the gasket(s) should be flat and free of scratches.
2. SCE Copper head gaskets are annealed in a vacuum oven after punching to provide soft malleable gaskets which are ready to use, do not use a torch to soften the gaskets.
3. Pro-Copper series head gaskets (P prefix) require:
  - A. sealant for coolant and oil passages
  - B. O-Ring combustion seals installed in the head or block. (P/N 31542 O-Ring kit).
4. When machining for new O-Rings make sure that the O-Ring diameter and location accommodates both bore opening and combustion chamber shape. This will determine the minimum inside diameter of the O-Ring.
5. If the combustion chamber or bore is so large that O-Rings must be placed less than .100" apart between cylinders, it is advisable to use a "figure 8" pattern for O-Rings (see figure #2). This allows for more even clamp load over the entire head surface.
6. Recommended O-Ring protrusion is not more than 25% of gasket thickness. Example: Gasket thickness .043", O-Ring height is .008" to .010". Gasket thickness .050", O-Ring height is .010" to .012".

**NOTE:** For extreme boost or heavy nitrous an O-ring-Receiver-Groove arrangement is recommended (see figure #3). When using a receiver-groove the wire may be higher than 25% of gasket thickness; wire height & width determines receiver groove depth & width by maintaining the relationships in the figure 3 illustration.

7. Good engine building practice requires clean flat surfaces and clean head bolt threads. If threads are tapped through the deck, use care in sealing threads to prevent coolant migration up the bolt.
8. As with any performance application it is strongly recommended that head bolts be re-torqued. Run the engine to operating temperature, shut down and allow it to cool completely. With the engine cold, follow the recommended torque sequence, one bolt at a time back the fastener off just enough to relieve the friction set, then re-torque to specifications.

**Instructions can also be found at [SCEgaskets.com/instructions](http://SCEgaskets.com/instructions)**







# Accu-Seal Pro™ Premium Intake Gaskets



Figure 1



Figure 2

## INSTALLATION INSTRUCTIONS

### STEPS:

1. Before installing the gaskets perform a visual check to ensure that no damage occurred during shipping.
2. Good engine building practice requires clean sealing surfaces. If the engine does not have a separate valley cover, place clean shop towels in the lifter valley to catch debris from cleaning. Prevent debris from falling down the ports by placing a wadded paper towel just inside each port. When surface cleaning is finished you will pull the debris out with the paper towel. Run a tap down all manifold bolt holes & clear debris. Being careful not to gouge the surfaces, scrape all gasket residue and sealant from the cylinder heads. If your engine does not have a separate valley cover, carefully clean the front & rear manifold sealing surfaces (sometimes called China Walls). Use a solvent degreaser to remove all oil residue.
3. Paying special attention to the front & rear manifold end sealing areas, clean all sealing surfaces of the intake manifold in the same manner as the cylinder heads.
4. Apply an even coat of Gasgacinch (SCE p/n G1614) on one-cylinder head sealing surface. Immediately apply an even coat of Gasgacinch on the cylinder head side (opposite red bead seals) of one intake gasket. Position the gasket on the head so it

is aligned properly with the intake ports (**SEE FIGURE 1**) & apply even pressure to the gasket affixing it in the aligned position. Do not apply sealant to the manifold side (with red bead seals) of the intake gasket. Repeat this procedure for the opposite intake gasket.

5. If your engine has a separate valley cover the intake manifold can now be installed, according to step 6. If your engine does not have a separate valley cover SCE recommends sealing the China Walls with High Temp RTV silicone (SCE p/n G1613). On the clean China Walls place a heavy bead of silicone. The objective is to create a thick bead about 1/4" to 3/8" high, properly done it will resemble a caterpillar (**SEE FIGURE 2**) on the front & back walls that will also adhere to the clean underside of the intake manifold.

6. Place the intake manifold in position. Using clean (or new) manifold bolts, finger tighten each bolt. Torque the intake manifold bolts to manufacturer recommendation (most often 25 -30-foot pounds) using an inside-out, criss-cross sequence. Allow the engine to sit for at least 2 hours so the silicone end seals will cure properly.

*Instructions can also be found at [SCEgaskets.com/instructions](http://SCEgaskets.com/instructions)*

# **Accu-Seal Pro™ Burst Panel Gaskets**

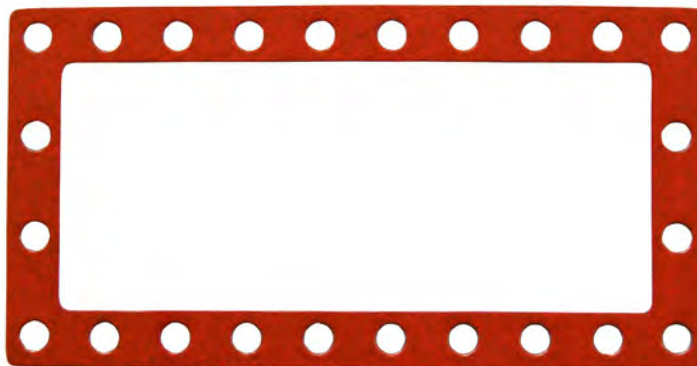

## **Features & Benefits:**

- Steel-core, high density facing material .040" thick.
- SCE's signature red Teflon® coating.
- Dependable sealing, re-usable.
- Non-Stick, will not absorb fuel or oil

## **Available for small and large burst panel sizes.**

- 3.250" Small burst panel gaskets - 329171 packaged 2 per set
- 329171-10 Dyno Pak packaged 10 per set.
- 3.250" Large burst panel gaskets - 329170 packaged 2 per set
- 329170-10 Dyno Pak packaged 10 per set.

## **Installation Instructions**

### **STEPS:**

1. Thoroughly clean all sealing surfaces.
2. Place 2 bolts on opposite ends through front frame, place front gasket over bolts in frame with red side toward frame.
3. Place burst panel on front frame/gasket with SFI label facing out, place rear gasket on frame/front gasket/burst panel assembly with red side toward manifold mounting surface.
4. Place assembly on manifold and hand tighten all 24 bolts
5. Torque bolts (not to exceed 20 IN/LB) from center of frame outward.

**Instructions can also be found at [SCEgaskets.com/instructions](http://SCEgaskets.com/instructions)**

# Accu-Seal Pro™ Tuff-Bak™ Valve Cover Gaskets

**Recommended Uses:** Racing engines with vacuum pumps, forced induction, high performance.



Figure 1

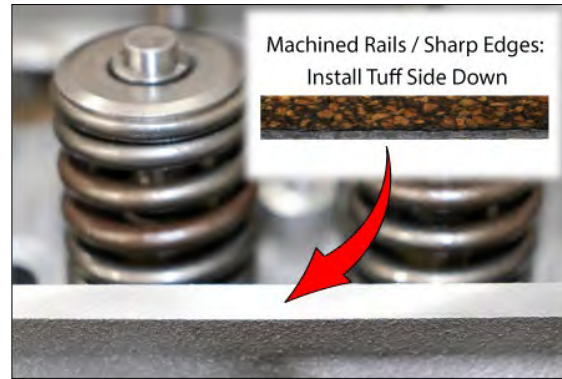

Figure 2

## INSTALLATION INSTRUCTIONS

### STEPS:

1. Ensure all sealing surfaces are clean and free of adhesives and old gasket residue. Use care when scraping aluminum rails as they can be damaged by sharp blades.
2. If the valve cover design is symmetrical there are two options for installation:
  - a. Porous cast-iron rails seal better with the cork side against the head (see figure 1).
  - b. Machined rails can be narrow and sharp, to prevent cutting the gasket, place the Tuff-Back side against the head (see figure 2).
3. Though not required, valve cover gaskets are commonly affixed to the valve cover with an adhesive. Silicone sealer is NOT recommended for this purpose. Use a gasket adhesive such as Gasegacinch (SCE part number G-1614).
4. Valve cover bolts should not be over-tightened as thin metal covers may dimple and aluminum threads may strip ( $\frac{1}{4}$ " coarse thread torque value = 6-8 ft lbs).
5. It is recommended to re-check bolt torque after 2 heat cycles.

*Instructions can also be found at [SCEgaskets.com/instructions](http://SCEgaskets.com/instructions)*

# Graph-Form™ Exhaust Gaskets

**Graphite to Take the Heat. Extra Thick to Conform.**



## Features & Benefits:

- **Recommended Uses:** Excellent seal for warped, pitted, or uneven manifolds or headers.
- .150" Thick
- Compressible up to .062"
- Medium Density 75% Graphite content material with Kevlar® reinforcement
- Seals Severely Warped Flanges
- Strength and Durability for Easy Handling
- Withstands Sustained High Temp Operation

## INSTALLATION INSTRUCTIONS

### STEPS:

1. Clean both sealing surfaces ensuring old gasket material has been removed.
2. Clean/restore cylinder head exhaust bolt threads with appropriate thread tap.
3. Use new manifold/header bolts and washers
4. Lubricate bolt threads with Hi-Temp Anti-Seize lubricant.
5. Hang the header or manifold loosely on the cylinder head using the two opposing end bolts leaving at least 3/16" between the head and manifold/header.
6. Slip the gasket into position making sure both end slots are fully bottomed on the bolts.
7. Snug the two end bolts, then install & snug the remaining bolts.
8. Beginning at the center of the manifold/header, tighten each bolt to the appropriate torque value (recommended torque for 3/8" x 16 pitch grade 5 bolts is 23-31 ft lbs.).

*Instructions can also be found at [SCEgaskets.com/instructions](http://SCEgaskets.com/instructions)*

# Pro-Copper™ Exhaust Gaskets

**Recommended Uses:** Premium solution for racing, turbo-charged, & exotic fuels.

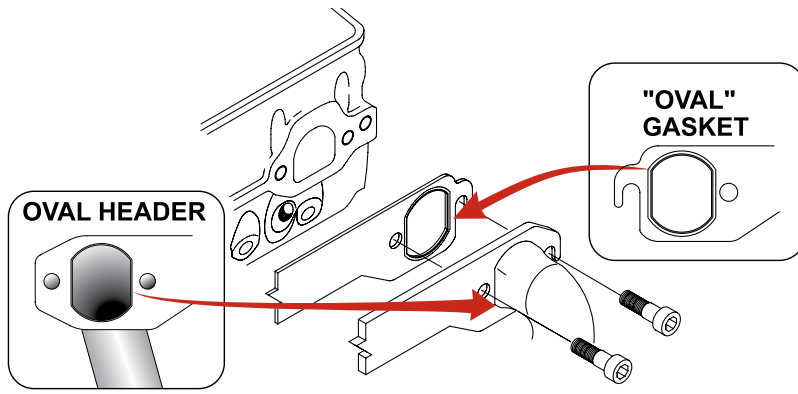

Match gasket shape to header shape

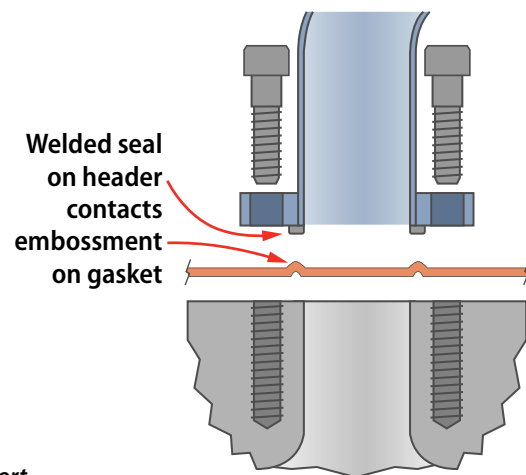

## INSTALLATION INSTRUCTIONS

**Note:** Pro-Copper exhaust gaskets will provide years of leak free performance if these simple steps are followed. However, **mis-matched gaskets** (such as a D-port gasket on an oval header) **will cause leaks** because the embossment is not in complete contact with the raised weld bead of the header.

### STEPS:

1. Determine the shape & size of the header or manifold opening. The shape of the cylinder head exhaust port is of secondary concern if there is adequate sealing surface for the header opening.
2. Select the SCE Pro-Copper exhaust gasket which most closely matches the shape and size of the header or manifold opening (see illustration above). Ensure the embossed sealing bead aligns with the raised weld bead of the header sealing surface when assembled.
3. Clean and lubricate the threads in the cylinder head so full clamping is achieved when bolts are torqued. Once the gasket is fully seated the bolts will not loosen because the gasket is solid metal and will not shrink from repeated heat cycling.
4. Install gaskets and torque to specification. Proper torque for new lubricated 3/8" x 16 grade 5 bolts is 23 to 31 ft lbs.

**Extreme heat applications such as towing may cause the gasket embossment to relax or flatten slightly as indicated by a "ticking" sound at idle. Do not discard the gasket; simply re-torque the bolts, 1 re-torque is usually sufficient for permanent sealing.**

Instructions can also be found at [SCEgaskets.com/instructions](http://SCEgaskets.com/instructions)



## **SBBK™ - Short Block Base Kits**



**Note:** Provides remaining gaskets and seals common to the engine type, regardless of customization.

### **INSTALLATION INSTRUCTIONS**

#### **STEPS:**

- 1.** Thoroughly clean and degrease component mating surfaces.
- 2.** Install rear main seal:
  - Lubricate sealing lip area with clean engine oil.
  - Install block-side split seal with undercut of seal lip facing inward (on oil side of engine block).
  - Install crankshaft.
  - Install main-cap split seal or one-piece rear seal. Some engines require rear main bearing cap to block seals, be sure they are fully seated (it may be necessary to move rear main cap in a slight up and down motion while inserting side cap seals).
  - Install remaining main caps in their original location and orientation. Tighten main cap bolts to factory torque specification.
- 3.** Install timing cover oil seal in timing cover, lubricate sealing lip.
- 4.** Apply Gasgacinch (SCE p/n G1616) on block to hold timing cover gasket in place, affix timing cover gasket over dowels and apply Gasgacinch to gasket. Install timing cover and bolts.
- 5.** Install oil pan. To install 4-piece pan gaskets, apply Gasgacinch to both sides of pan rail gaskets and front/rear end seals. To install 1-piece pan gasket, use only a small dab of silicone (both sides of gasket) at the four corners (interface of Timing Cover/pan and Rear Main cap/pan)
- 6.** Install water pump gasket(s) onto water pump using Gasgacinch gasket sealer. Install water pump.
- 7.** Install water outlet gasket onto water outlet using Gasgacinch gasket sealer. Install water outlet onto intake manifold.

**Instructions can also be found at [SCEgaskets.com/instructions](http://SCEgaskets.com/instructions)**

## Split Rear Main Seals

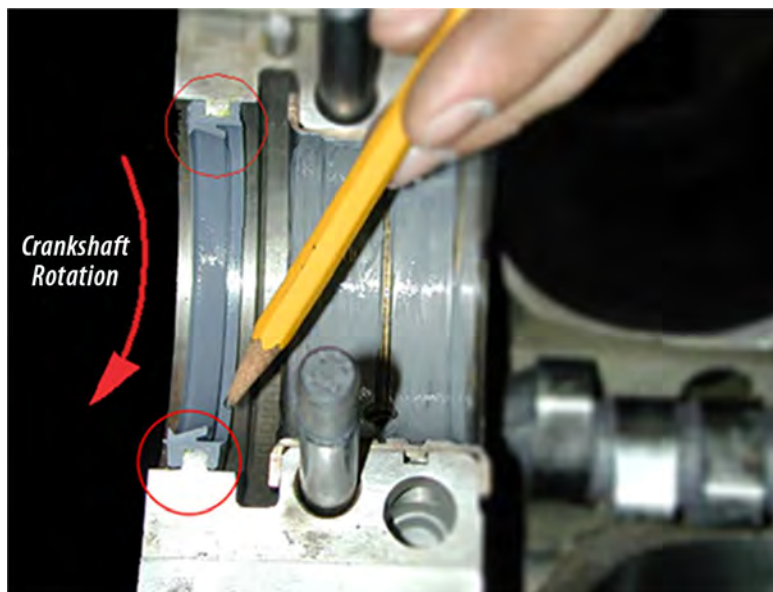

### INSTALLATION INSTRUCTIONS

**Note:** Rotation: Upon close inspection you will notice fine ribs or “vanes” on the seal contact surface. The vanes of automotive rear main seals are molded directionally to ‘pump’ oil toward the crankcase with standard counterclockwise or “left rotation” when viewed from the driver’s seat (arrow). Many marine engines are “right rotation” also called “reverse rotation”, correct rear main seals for these marine engines will have vanes molded in the opposite direction from the image above.

### STEPS:

1. Sealant: SCE recommends a light layer of Gasegacinch (SCE p/n G1616) on the seal backing and on the main-cap-to-block mating surface outboard of the seal. Do not use silicone on the seal backing.
2. Alignment: split rear seals are designed to be installed with seal ends even with block/cap mating surfaces so that the seal ends butt at the parting line of the block & cap. Do not rotate.
3. Seal Orientation: correctly installed as shown above, the lip should extend inwardly, toward the engine crank case (circles). This orientation of the seal causes the seal lip to be pressed against the crankshaft as crankcase pressure increases.
4. Lubrication: use clean motor oil to pre-lubricate the seal contact surface prior to crankshaft installation.
5. Repeat all steps for opposite seal-half before cap installation.

*Instructions can also be found at [SCEgaskets.com/instructions](http://SCEgaskets.com/instructions)*

# Accu-Seal Pro™ Molded One-Piece Oil Pan Gaskets

## INSTALLATION INSTRUCTIONS

### STEPS:

1. Scrape and clean engine block and oil pan mating surfaces. Remove any oil or grease with proper cleaner.
2. Check oil pan holes and flanges for flatness. Check bolts for stripped threads or heads, threads must be straight and clean, replace as necessary.
3. To allow for differences in aftermarket oil pan stampings, use "small" dab of RTV sealant ONLY at rail ends front and back of oil pan as shown

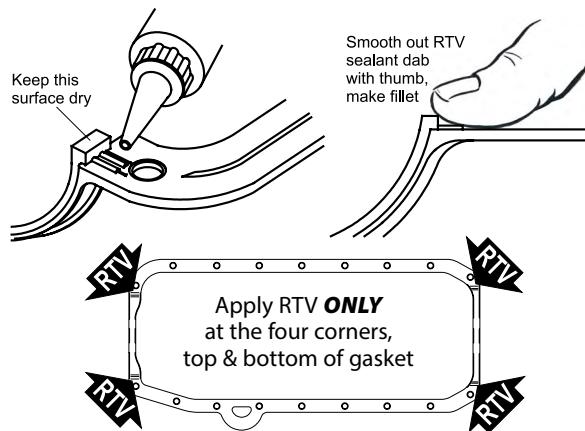

4. Install SCE "One-Piece" oil pan gasket to engine block paying close attention to tab inserts at rear main cap and front cover assembly, then set oil pan in place carefully. Install oil pan bolts and torque to manufacturer's requirements in sequence, "crush limiters" will prevent damage to gasket from over tightening.

5. Torque oil pan bolts.

Basic torque specifications for Chrysler, Ford, and GM engines.

**Chrysler**- Torque to 100 inch-lbs.

**Ford** - Torque to 100 inch-lbs.

**GM** - Torque to 100 inch-lbs.

(For Chevy small block V6 and V8 engines 1986 and later).

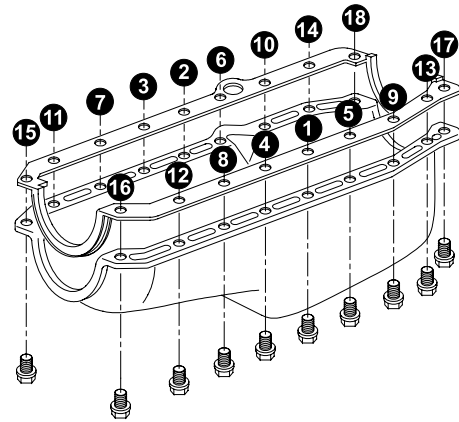

Follow tightening sequence as shown above

6. Add engine oil and check for leaks, then start engine and re-check for oil leaks.

## UNDER-CAR INSTALLATION INSTRUCTIONS

For under car installation of SCE "One-Piece" oil pan gaskets it is helpful to use a light adhesive such as "3M 88" aerosol or "Gasgacinch" (SCE p/n G1614) to hold the gasket in place during assembly. For ease of assembly please follow these tips.

1. Lay the gasket block side up and apply a light coat of adhesive on both pan rails, let tack for 5 minutes. Apply RTV sealant as shown in Step-3
2. Thoroughly clean all oil and grease from engine mating surfaces and apply a light coat of adhesive to engine block rails, let tack for 5 minutes.
3. Locate the pan gasket on the engine using 1 bolt in center of each pan rail, then stick gasket in place paying close attention to tab inserts at rear main cap and front cover as required.
4. Remove locating bolts and install oil pan and bolts, torque as required.

## 4-Piece Oil Pan Gaskets

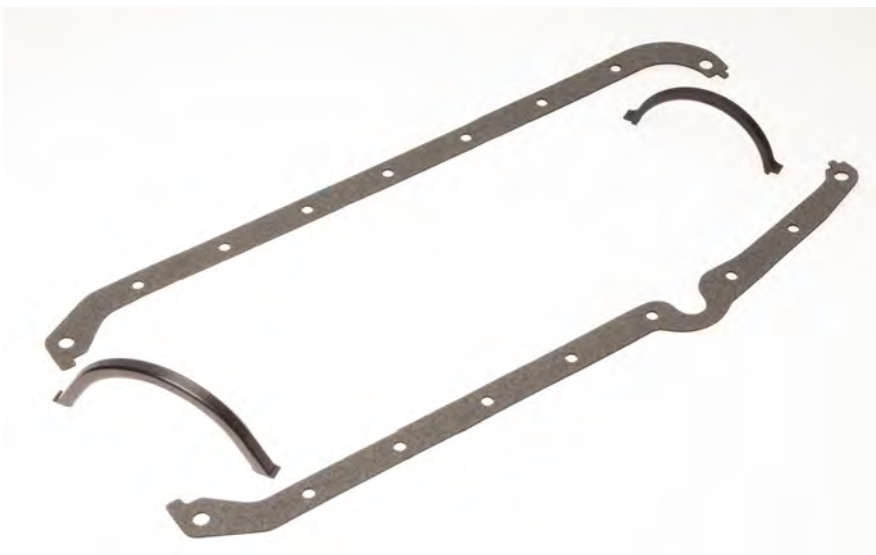

### INSTALLATION INSTRUCTIONS

#### STEPS:

1. Prepare all sealing surfaces including block, pan, timing cover and rear main cap by removing old gasket material, sealants, and oil residue.
2. Inspect for dimples at bolt holes in steel pan rails and flatten as needed.
3. Apply Gasgacinch gasket compound to timing cover and rear main cap sealing surfaces.
4. Apply Gasgacinch gasket compound to engine-side of pan end-seals, allow gasket compound to become tacky, then install and position pan end-seals.
5. Apply Gasgacinch gasket compound to block along pan rails.
6. Apply Gasgacinch gasket compound to engine side of pan rails, allow gasket compound to become tacky, then install and position pan rails.
7. A small amount of Athesil RTV silicone sealer may be used at rail / seal joints to eliminate oil weeping.

**CAUTION:** Use silicone sealant sparingly, excess silicone may be extruded into the crankcase, break free and eventually block the oil pump pick-up screen.

8. Position oil pan, install and snug four corner bolts first, then install and snug all bolts, then tighten all bolts to 100 inch-lbs starting at the center and working outward.

*Instructions can also be found at [SCEgaskets.com/instructions](http://SCEgaskets.com/instructions)*



## **PRO-COPPER™**

*Solid Copper Head Gaskets for Exotic Fuels & Unlimited Boost.  
The Original Embossed Copper Exhaust Gaskets.*

## **VULCAN CUT-RING™**

*Stainless Steel Cut-Ring & Composite Head Gaskets.  
No sealant. No Machining.*

## **MLS SPARTAN™**

*Multi-Layer Stainless Steel Head Gaskets • Bolt-On.  
No Sealant. Multiple Thicknesses.*

## **ICS™**

*Integral Combustion Seal • The World's First Self-Sealing Copper Head Gasket.*

**NEW!**

## **ATHESIL™**

*RTV Silicone Sealant. Designed specifically for high-performance engines.*



## **ACCU-SEAL PRO™**

*Premium Engine Gaskets, Seals & Sets • Composite & Embossed Steel Shim Head Gaskets*



## **GRAPH-FORM™ EXHAUST**

*Graphite & Kevlar to Take the Heat. Conforms to Irregular Surfaces. .150" Thick*



### **ATHENA-SCE INC**

424 Williams Springs Rd • Mount Pleasant, TN 38474  
800-GASKET-0 (427-5380) PHONE • 931-325-0110 FAX  
sales@SCEgaskets.com • SCEgaskets.com •    