



PRODUCT CATALOG

COMPLETE BODY & WINDOW LINE

2019

40 CELEBRATING
YEARS
EST. 1979

PRODUCTS AT THE FOREFRONT OF
QUALITY & PERFORMANCE



RACE CAR BODIES & ACCESSORIES

ABOUT OUR COMPANY

Five Star Race Car Bodies, a division of Five Star Fabricating, Inc. was formed by Carl Schultz and Fran Prestay in the late 1970s in Twin Lakes, Wisconsin. It began as a side job for the two in response to a need for innovative sheet metal products in the stock car racing industry. Fran owned an auto service shop across from Carl's local plumbing and heating business, and after a rough night at the local short track, Fran asked Carl to produce a set of sheet metal fenders for his car since finding stock parts in the salvage yard was difficult and time consuming.

The new fenders were a hit with other racers, who wanted them for their own cars. Seeing an opportunity and eager to accept a challenge, Carl and Fran began producing components for the 1979 Camaro. Word of mouth and a small ad in Stock Car Racing magazine led to a tremendous response from racers across the country.

From that '79 Camaro body, the product line quickly diversified and expanded to include tough and durable thermoformed polypropylene, light weight hand-laid fiberglass and advanced composite race car body components, moving Five Star to the forefront of the industry. We are experts in manufacturing large, complex composite body panels that require both structural integrity and aesthetic quality.

After becoming an industry leader in formed windows from existing branded polycarbonate, our engineers devised improvements in material composition and coatings which led to the development of our own superior line of polycarbonate. Five Star premium racing windows are the #1 windows used in all motorsports, creating new standards in toughness, durability and weather resistance.

Five Star has been privately owned by the Schultz family since 2010. We lead the industry in manufacturing with over 125 employees and 200,000 square feet of floor space dedicated to the design, manufacture, and distribution of body panels, windows and accessories.

Our multi-unit facility is on the leading edge of technology, production capability and logistics. We are ready to put our experience and expertise to work for you.

Five Star Bodies designs and manufactures composite, plastic and polycarbonate parts for NASCAR, Circle Track, Drag Race, Road Race, Off Road applications and much more!

Five Star continues to be dedicated to innovation. As we accept large, more advanced projects and emerge into new markets and industries, we will continue to maintain our deep roots in auto racing, putting our experience and expertise to work for you, our valued customers, by providing durable, high quality parts for years to come!

QUALITY & SERVICE



This award of ISO 9001:2008 was issued after a diligent 18 month process of assessing and enhancing manufacturing, quality processes and procedures. Systems were audited for compliance by an external, accredited organization. In order to maintain its certification, Five Star is committed to review and continually improve its processes through follow-up audits.

This certification is an important step in assuring that customers continue to receive the very best in quality and service from Five Star Fabricating, Inc. and Five Star Coatings Group, Inc.

WHAT DOES ISO CERTIFICATION MEAN TO OUR CUSTOMERS?

The renowned ISO 9001:2008 certification means the organization has developed a quality management system and has demonstrated its commitment to enhancing customer satisfaction with processes for continual improvement and the assurance of conformity to customer, statutory and regulatory requirements.

- › Commitment from Top Management
- › Human Resources
- › Best in Class Customer Satisfaction
- › Original Design and Development
- › Best Purchasing Practices
- › Efficient Production Processes
- › Control of Customer Property
- › Inspection Processes
- › Facility Maintenance
- › Internal Audits
- › Corrective and Preventive Action

OUR QUALITY POLICY

“Five Star is committed to total customer satisfaction by supplying consistent high quality, best in class products at competitive prices.”

ADVANCED BODY TECHNOLOGY

WHAT THIS MEANS TO YOU...

The term “Advanced Body Technology” is a big statement we use to assure that our customers are provided with **BEST-IN-CLASS BODIES.**

Our original products are developed with these 5-steps to keep Five Star at the forefront of quality and performance.

1) CUTTING EDGE AERO DESIGNS

Aerodynamically engineered designs using the latest processes such as CFD and Wind Tunnel testing by qualified engineers. All of our bodies are designed with maximum downforce and peak front to rear aero balance!

2) INNOVATION

STATE OF THE ART MATERIALS AND PROCESSES:

We NEVER sit still! We continually seek performance gains by researching and developing new materials and manufacturing processes.

ORIGINAL DESIGNS: Our 9 member Product Development Team monitors the continual improvement of original new products, processes and ideas.

3) REPEATABLE FIT

Replacement parts that fit the same, every time assure that our bodies are the EASIEST TO INSTALL and maintain.

4) TESTED TOUGH

As you can see from several of our You Tube videos, a vital part of our R&D process includes various series of highly destructive tests to gauge optimal performance of our parts. **NOBODY MAKES STRONGER PARTS.** “Spend more time racing and less money replacing!”

5) ULTRA LIGHT

Cutting weight without sacrificing strength and durability. We strive for the lightest allowable weight in all markets we serve. We specialize in race car body weight reduction without aero deflection or adding unnecessary cost.

TABLE OF CONTENTS

ULTRAGLASS.....	4
ADVANCED COMPOSITES.....	5
HIGH-IMPACT MOLDED PLASTICS	6
POLYCARBONATE WINDOWS	7
NEW PRODUCTS.....	8-9
NEW LATE MODEL BODY	10-13
ABC GREENHOUSE STYLE BODIES.....	14-17
ABC TRADITIONAL ROOF BODIES.....	18-21
LATE MODEL STOCK BODIES	22-25
NASCAR K&N/ARCA COMPOSITE BODIES	26-31
S2 SPORTSMAN BODIES.....	32-35
PAVEMENT MODIFIED BODIES.....	36-39
SHORT TRACK TRUCK BODIES	40-43
STRAIGHT-UP METAL BODIES	44-45
STREET STOCK BODIES	46-49
MD3 DIRT LATE MODEL BODY PANELS.....	50-57
MD3 DIRT MODIFIED BODY PANELS	58-61
DIRT GRAND NATIONAL BODIES.....	62-63
DRAG BODIES.....	64-73
OFF ROAD TRUCK BODIES.....	74-75
ROAD RACING BODIES	76-79
RACING WINDOWS.....	80-94
BODY ADD-ONS & MOUNTING KITS	95-123
TERMS & CONDITIONS	126-127

NOTE: PRICING SUBJECT TO CHANGE WITHOUT NOTICE.

- NEW LATE MODEL
- ABC
- LATE MODEL STOCK
- NASCAR PRO SERIES
- ARCA RACING SERIES
- S2
- PAVEMENT MODIFIED
- SHORT TRACK TRUCK
- STRAIGHT UP METAL
- STREET STOCK
- MD3 DIRT LATE MODEL
- MD3 DIRT MODIFIED
- DIRT GRAND NAT'L
- DRAG BODIES
- OFF ROAD
- ROAD RACING
- RACING WINDOWS
- BODY ADD-ONS

THE PROVEN INDUSTRY LEADER IN RACE CAR BODY TECHNOLOGY

ABOUT OUR PREMIUM BODY MATERIALS

#1

ULTRAGLASS COMPOSITES

NOT THE SAME OLD SCHOOL FIBERGLASS
OTHER BODY COMPANIES OFFER



FIBERGLASS REDEFINED

THIS EXCLUSIVE COMPOSITE BLEND USES SPECIAL FABRICS AND LAMINATING PROCESSES DEVELOPED BY AND ONLY AVAILABLE FROM FIVE STAR!

ULTRA-TOUGH

- ▶ Unmatched impact resistance, no other composite is stronger! Panels that deflect 300% further before breaking = less debris on the race track and less time in the pits!

ULTRA-LIGHT

- ▶ Over 30% lighter than standard hand-laid composites
- ▶ Parts made to under 5% target weight tolerance

ULTRA-FAST

- ▶ Zero surface deflection at all racing speeds

ULTRA-SMOOTH

- ▶ All panels are made with a smooth inner surface (LMSC panels dyed black to eliminate painting), are buffed to an excellent surface finish and wrapped for ultimate protection!

ULTRA-GREEN

- ▶ 93% reduction in harmful emissions during the manufacturing process. All parts are manufactured in our clean EPA environmentally compliant facility.



IF YOU ARE TIRED OF REPLACING BODY PANELS OVER & OVER,
PERHAPS IT'S TIME TO SWITCH TO FIVE STAR ULTRAGLASS!

ABOUT OUR PREMIUM BODY MATERIALS

#2

ADVANCED COMPOSITES

THE LIGHTEST AND STRONGEST BODY PANELS ON THE MARKET WITHOUT COMPROMISING RIGIDITY!



EXCLUSIVE LAMINATE BLEND

ADVANCED COMPOSITES BLENDS ARE MADE WITH THE SAME MANUFACTURING PROCESSES AS CARBON FIBER FOR SIMILAR PERFORMANCE, WITHOUT THE ADDED COSTS!

PRECISION WEIGHT CONTROL

- Up to 47% weight savings over standard fiberglass composite panels!
- Parts made within a 5% target weight tolerance

STRONG

- Tremendous shear (tear) resistance
- Zero surface deflection at high speeds

FLAWLESS FINISH

- All panels are made with a smooth inner surface
- Buffed to an excellent surface finish and wrapped for ultimate protection!

ULTRA-GREEN

- 93% reduction in harmful emissions during the manufacturing process. All parts are manufactured in our clean EPA environmentally compliant facility.

DON'T BE FOOLED!

OTHERS MAKE FALSE CLAIMS ABOUT THEIR "LITE WEIGHT" HOODS & ROOFS

- THESE ARE CHEAP IMITATIONS AND ARE NOT EVEN CLOSE TO WHAT WE OFFER!
They try to mimic the fabrics we use, but they don't understand the entire manufacturing process which makes our parts the best!
- SOME WILL SIMPLY REDUCE THE AMOUNT OF MATERIAL used which results in a flimsy part. They will not retain their shape at high race speeds and will require additional bracing that adds additional weight to the installation.

THE QUALITY, PERFORMANCE AND DURABILITY YOU REQUIRE,
THAT NO OTHER BODY COMPANY CAN OFFER!

ABOUT OUR PREMIUM BODY MATERIALS

#3

HIGH-IMPACT MOLDED PLASTICS

UNSURPASSED IMPACT RESISTANCE & DURABILITY!



EXCLUSIVE PLASTIC MATERIALS

- Five Star uses our own state-of-the-art proprietary blend of plastic material that is **ULTRA-DURABLE, LIGHT WEIGHT** and holds up in the toughest racing conditions
- Engineered high elongation provides superior flexibility while maintaining structural integrity

UNIQUE FORMING PROCESSES

- Parts are formed using state-of-the-art computer automated thermoforming machines with temperature controlled cast aluminum tooling to assure superior shape consistency

CONSISTENT WEIGHT

- Parts made to under 5% target weight tolerance

NOTE: USE FIVE STAR PLASTIC PRIMER BEFORE PAINTING

Our Five Star brand Plastic Primer is specifically engineered for the special plastic materials we use. Other automotive grade primers on the market may not work at all.



THIS FEATURED PLASTIC IS USED IN THE MD3 BRAND.
THE PROVEN BEST BODY PANELS IN ALL DIRT RACING!

ABOUT OUR PREMIUM BODY MATERIALS

#4 POLYCARBONATE WINDOWS

USING OUR EXCLUSIVE OPTICAL GRADE MATERIALS THAT NOBODY ELSE CAN OFFER!



WE CAN CUSTOM FORM!!

- ▶ We offer in-house design and mold building for the windows you need
- ▶ CNC pattern cutting
- ▶ We can form windows from factory glass for limited quantity orders
- ▶ We can meet all of your other polycarbonate/acrylic needs - not only racing windows!
- ▶ Call Five Star Customer Service to get a quote on your custom project!

BENEFITS OF POLYCARBONATE

- ▶ Significant weight savings compared to glass!
- ▶ Enhances driver safety
- ▶ Can be formed into multiple shapes or styles

THE BEST OPTICAL CLARITY!

- ▶ We only use the highest Optical Grade Polycarbonate developed exclusively by, and only available from Five Star!
- ▶ Our material shall not be confused with the lesser optical and hard coating grade LEXAN Brand

FORMING/TRIMMING PROCESSES

- ▶ We invented our own forming process, which assures you superior optics and perfect fit!
- ▶ Computer controlled CNC routing ensures a perfect drop-in fit, every-time!

OUR HARD COATINGS

- ▶ Our world-renowned high tech coating process provides the highest abrasion and chemical resistance for unsurpassed durability and improved product life!
- ▶ Permanent anti-fog coating is included at no additional cost!
- ▶ Flexible coating is applied before molding which allows for rolling up to save on shipping costs



THE #1 WINDOWS USED IN ALL MOTORSPORTS!

ALL NEW FIVE STAR PRODUCTS!

ENTER THE NEW ERA

ALL NEW **2019 LATE MODEL BODY**
ALL NEW MODERN DESIGN & STYLE!



CAMARO
CAMRY
MUSTANG



- ✓ **NASCAR CUP SERIES GEN 6 STYLING**
- ✓ **AERODYNAMICALLY EQUAL**
- ✓ **SIMPLE INSTALLATION**

➤ Ordering info on pages: 10-13



SHORT TRACK TRUCK BODY

ALL NEW STYLING BASED ON
NASCAR TRUCK SERIES BODY

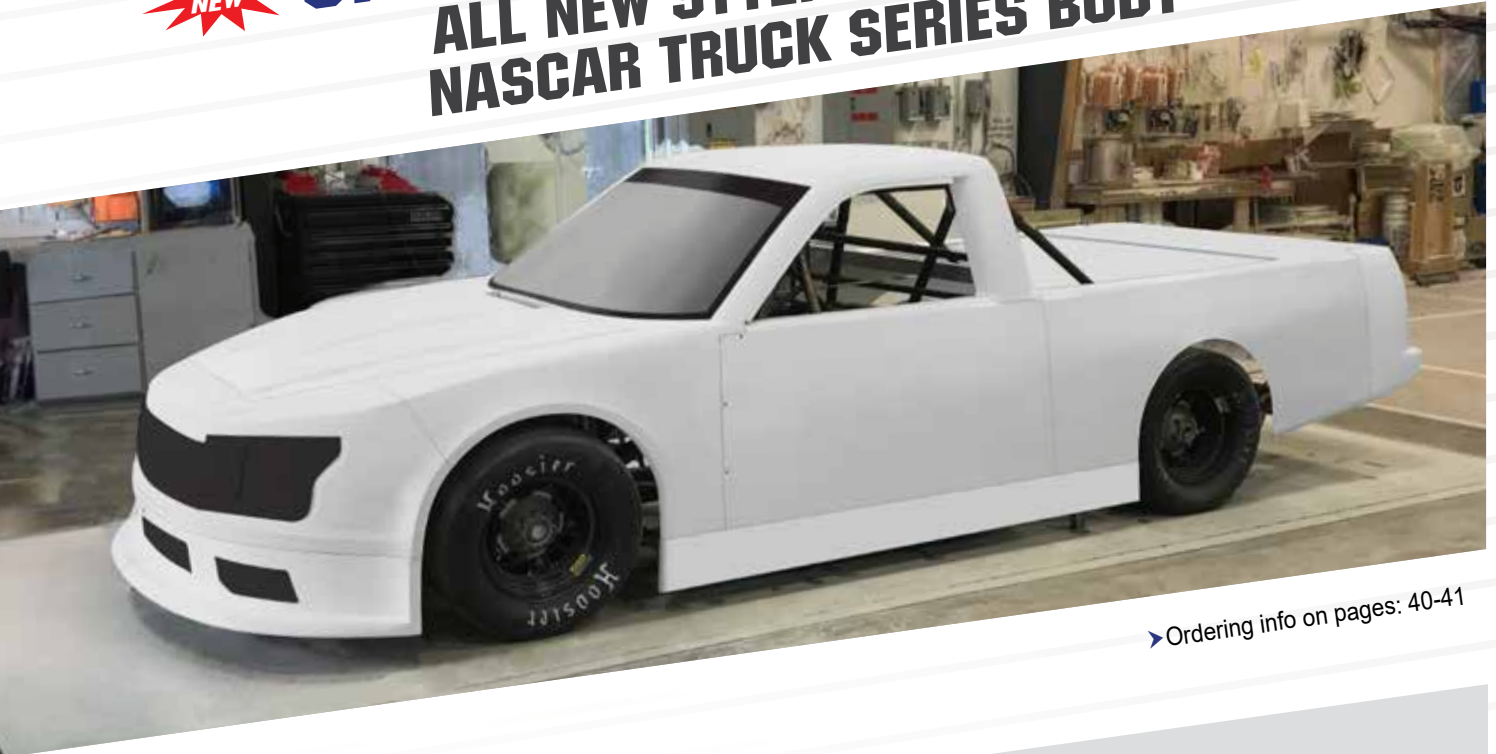

➤ Ordering info on pages: 40-41



CHEVROLET CAMARO PRO STOCK/PRO MOD FRONT CLIP

ALL NEW UPDATED GRILL & HEADLIGHT AREAS

FRONT CLIP SHOWN WITH ALL NEW
NOSE ID GRAPHICS KIT!



➤ Ordering info on pages: 64-65



2019 LATE MODEL BODY

The all new GREENHOUSE STYLE BODY is very easy to mount! The 2-piece roof configuration is 3" wider to allow for better driver access and provides room for a wider roll cage! Designed to run side by side with the current 2004 ABC body, AERODYNAMICALLY EQUAL!

MODERN STYLE & DESIGN

- » Designed to run side by side with the current 2004 ABC Body, aerodynamically equal
- » Styling based on the NASCAR Cup Series Body
- » Common body uses (3) different noses for brand identity
- » Lower air dam on nose molded in for correct aero equality
- » Added fender clearance for increased suspension travel

EASY TO INSTALL

- » Cowl Panel built into front greenhouse for ease of installation
- » Fenders can be mounted over or under the doors
- » Increased engine clearance

BUILT FOR DRIVER SAFETY

- » Flame retardant resin used in Ultraglass 2-piece greenhouse
- » 3" Wider 2-piece greenhouse allows for better driver access and a wider roll cage



The ABC Body program was established with the sole intent of controlling the shape of the late model body in order to provide an even playing field for all competitors. This body was designed with the full intent of the program in mind.

CHASSIS	ROOF HEIGHT	TREAD WIDTH	WHEELBASE
Offset/Straight Rail	47"	66" max	101-106"

Go to our downloads page at FIVESTARBODIES.com for complete body installation guidelines.

CHECK OUT WHY TOP TEAMS CHOOSE FIVE STAR!
www.FIVESTARBODIES.com/BETTERBODIES

BODY PACKAGES & OPTIONS

BODY PACKAGES		PN -W -B		PN -CB -R	
1	RE-SKIN PACKAGE Includes Aluminum Doors; High-Impact Molded Plastic Nose, Bumper Cover, Fenders, Quarter Panels & Rocker Panels	11002-10000-x	\$909	11002-10000-x	\$951
2	PACKAGE A Includes Aluminum Doors, Deck Lid & Deck Lid Hold-down strip; High-Impact Molded Plastic Nose, Bumper Cover, Fenders, Quarter Panels & Rocker Panels; Standard Composite Hood, Front & Rear Greenhouse; Ultraglass Cowl Insert	11002-10200-x	\$1,901	11002-10200-x	\$2,049
3	ECONOMY COMPLETE PACKAGE Includes Aluminum Doors, Deck Lid, Deck Lid Hold-down strip; High-Impact Molded Plastic Nose, Bumper Cover, Fenders, Quarter Panels & Rocker Panels; Standard Composite Hood, Front & Rear Greenhouse; Ultraglass Cowl Insert; 6½" 70° Unpainted Spoiler; Mar-Resistant Coated Windshield & Quarter Windows; Uncoated Rear Window	11002-10600-x	\$2,639	11002-10600-x	\$2,787
4	ADVANCED LIGHTWEIGHT COMPOSITE PANEL PACKAGE Includes Aluminum Doors, Deck Lid & Deck Lid Hold-down strip; High-Impact Molded Plastic Nose, Bumper Cover, Rocker Panels; Advanced Lightweight Composite Hood, Ultraglass Front & Rear Greenhouse, Cowl Insert, Fenders & Quarter Panels; 6½" 70° Unpainted Spoiler; Mar-Resistant Coated Windshield & Quarter Windows; Uncoated Rear Window	11002-10612-x	\$3,490	11002-10612-x	\$3,739

MUST SPECIFY THESE ITEMS WHEN ORDERING: Body Color (White -W; Black -B; Blue -CB; Red -R), Nose Style, Spoiler Size & Angle, Fender Size, Rocker Style

OPTIONS & UPGRADES +/- FROM PKG \$	PKG	-W	-B	-CB	-R
Fenders, Ultraglass	1,2,3		+\$144		+\$92
Greenhouse, front, advanced lightweight composite	2,3		+\$126		+\$132
Greenhouse, rear, advanced lightweight composite	2,3		+\$73		+\$75
Hood, advanced lightweight composite	2,3		+288		+\$281
Quarter Panels, Ultraglass	1,2,3		+\$220		+\$140
Rocker Panels, aluminum	1,2,3,4		+\$12		+\$7
Spoiler, 5" x 60" x 1/4", 70°, 90°	3,4		\$0		\$0
Spoiler Brackets, black powder-coated	3,4		+\$7		+\$7
Window, rear, mar-resistant coated	3,4		+\$114		+\$114

NOTE: All windows are pre-cut-to-fit, beveled & drilled with permanent black-out border unless specified otherwise

DELUXE BODY MOUNTING KIT



BY PURCHASING A COMPLETE KIT
vs. individual components!

EVERYTHING YOU NEED TO MOUNT YOUR NEW BODY!!

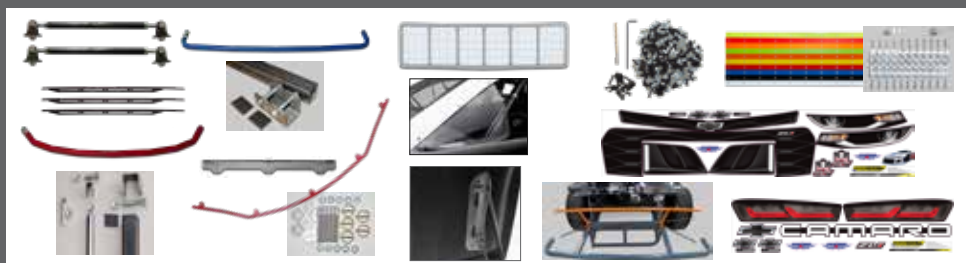

- Body/Window & Nose Braces
- Universal Bracing Kits
- Front & Rear Bumpers
- Bumper Mounting Kits
- Right Side Door Support
- Nose & Tail ID Graphics
- Wear Strips & Attachment Kits
- Hood Pin Brackets & Pins
- Rear Deck Mounting Kit
- Nose Screen
- Vent Window
- Window Installation Kit

PN# 11002-72520 \$763.50

more info pg 100

NEW LATE MODEL
ABC
LATE MODEL STOCK
NASCAR PRO SERIES
ARCA RACING SERIES
S2
PAVEMENT MODIFIED
SHORT TRACK TRUCK
STRAIGHT UP METAL
STREET STOCK
M3 DIRT LATE MODEL
M3 DIRT MODIFIED
DIRT GRAND NATIONAL
DRAG RACING
OFF ROAD
ROAD RACING
RACING WINDOWS
BODY ADD-ONS



REPLACEMENT PANELS FOR NEW LATE MODEL BODY

REPLACEMENT PANELS		-W	-B	RACER	-CB	-R	RACER
Bumper Cover, rear, high-impact molded plastic	11002-45051-x			\$111	11002-45051-x		\$118
Deck Lid, aluminum	661-310A-x			\$49	661-310A-x		\$49
Deck Lid Hold-down strip, molded plastic	XM 000-310H-x			\$6	XM 000-310H-x		\$6
Door, aluminum (specify left or right)	11002-21033-xLorR			\$80	11002-21033-xLorR		\$80
Fender, high-impact molded plastic	11002-23051-xLorR			\$111	11002-23051-xLorR		\$115
Fender, Ultraglass	11002-23013-xLorR			\$183	11002-23013-xLorR		\$207
Greenhouse, Front, standard composite (w/Built-in Cowl Panel)	11002-51311-x			\$346	11002-51311-x		\$384
Greenhouse, Front, Ultraglass (w/Built-in Cowl Panel)	11002-51313-x			\$472	11002-51313-x		\$516
Greenhouse, Rear, standard composite (w/Built-in Cowl Panel)	11002-51511-x			\$393	11002-51511-x		\$440
Greenhouse, Rear, Ultraglass (w/Built-in Cowl Panel)	11002-51513-x			\$466	11002-51513-x		\$515
Hood, standard composite	11002-33011-x			\$154	11002-33011-x		\$175
Hood, advanced lightweight composite	11002-33011L-x			\$442	11002-33011L-x		\$456
Quarter Panel, Ultraglass	11002-27313-xLorR			\$228	11002-27313-xLorR		\$264
Quarter Panel, high-impact molded plastic	11002-27351-xLorR			\$118	11002-27351-xLorR		\$124
Rocker Panel, aluminum (fits either side)	000-5501A-x			\$42	000-5501A-x		\$42
Rocker Panel, molded plastic (fits either side)	000-5501P-x			\$30	000-5501P-x		\$35
WINDOWS				PART #		RACER	
Window, Quarter, mar-resistant coated, black-out border				11002-65153-LorR			\$46
Window, Rear, mar-resistant coated, black-out border				11002-61153			\$305
Window, Rear, uncoated, black-out border				11002-61151			\$191
Windshield, pre-cut to fit, black-out border, 1/8"				11002-63253			\$350
Window, Door Vent, pair, pre-cut to fit, 1/8"				11002-66222			\$28
NOSES	CHEVROLET CAMARO	FORD MUSTANG	TOYOTA CAMRY			RACER	
Nose, plastic -B -W	11132-41051-x	11322-41051-x	11712-41051-x			\$120	
Nose, plastic -CB -R	11132-41051-x	11132-41051-x	11712-41051-x			\$125	
SPOILERS: 60" WIDE	5" (90°)	5" (70°)	6½" (90°)	6½" (70°)	RACER		
Complete, aluminum	11002-47359	11002-47357	11002-47369	11002-47367	\$105		
Complete, aluminum, black	11002-47359-B	11002-47357-B	11002-47369-B	11002-47367-B	\$112		
Brackets, aluminum	11002-47369-1	11002-47367-1	11002-47369-1	11002-47367-1	\$75		
Brackets, aluminum, black	11002-47369-1B	11002-47367-1B	11002-47369-1B	11002-47367-1B	\$82		
Blades, polycarbonate	11002-47359-2	11002-47357-2	11002-47369-2	11002-47367-2	\$30		
TEMPLATES	CHEVROLET CAMARO	FORD MUSTANG	TOYOTA CAMRY	RACER			
Complete Set, wood	11132-82091	11322-82091	11712-82091	\$128			
Complete Set, aluminum	11132-82033	11322-82033	11712-82033	\$497			
Nose, side-to-side, wood	11002-82491	11002-82491	11002-82491	\$43			
Roof, front, wood	11002-82591	11002-82591	11002-82591	\$21			
Roof, front, aluminum	11002-82533	11002-82533	11002-82533	\$60			
Complete Template set includes: Fenders; Nose Centerline; Body Centerline; Rear Roof side-to-side							

*Yellow composite body panels may be special order parts, contact Five Star for availability.

ENHANCE YOUR BODY WITH THESE GREAT BODY ADD-ONS & ACCESSORIES



□ **RADIATOR DUCTS**
.....pg 116

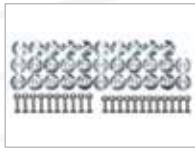

□ **SPOILER MOUNTING KITS**
.....pg 105



□ **REAR DECK MOUNTING KIT**
.....pg 106



□ **NOSE BRACES TELESCOPING BRACES**
.....pg 109-110



□ **BUMPERS MOUNTING KITS**
.....pg 120



□ **DOOR VENT WINDOWS**
.....pg 115

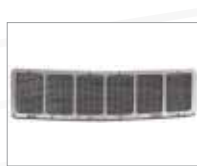

□ **NOSE SCREENS**
.....pg 97



□ **HOOD PIN BRACKETSKITS**
.....pg 118



□ **WINDOW BRACES**
.....pg 111



□ **WINDOW INSTALL KITS**
.....pg 105



□ **HOOD PROPS HOOD HINGES**
.....pg 119



□ **BODY MOUNTING TABS**
.....pg 107



□ **BRAKE DUCTS HOSES**
.....pg 115



□ **BACK-UP PLATE KITS**
.....pg 111



□ **FIVE STAR RIVETS/WASHERS**
.....pg 104



□ **DOOR SUPPORT**
.....pg 107



□ **RACING MIRRORS**
.....pg 114



□ **POLYCARBONATE RUB RAILS**
.....pg 114



□ **BODY BRACING**
.....pg 108

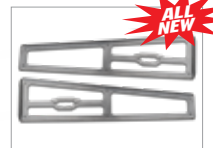

□ **QUARTER PANEL BODY BRACES**
.....pg 109



□ **WINDOW CLEANER**
.....pg 122



□ **SC1 DETAILER SPEED WAX**
.....pg 123



□ **PLASTIC PRIMER**
.....pg 122

FEATURED PRODUCTS

HOT TIP

PROFESSIONAL BODY INSTALLERS USE THESE PRODUCTS...YOU SHOULD TOO!

#1

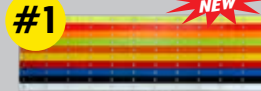

WEAR STRIPS

PROTECT THE LOWER EDGE OF YOUR NOSE IN STYLE!

DETAILS » PG 117

#2



COLD AIR BOXES

PATENTED FLOW DESIGN!
Flow bench tested for peak air flow!!

DETAILS » PG 112

#3



ROOF LOCATING FIXTURE

THE FASTEST, EASIEST WAY to mount a body on your own!

DETAILS » PG 106

#4



NOSE & TAIL ID KITS

GET THE OEM LOOK WITH OUTSTANDING REALISTIC DETAILS!

DETAILS » PG 96

NEW LATE MODEL
ABC
LATE MODEL STOCK
NASCAR PRO SERIES
ARCA RACING SERIES
S2
PAVEMENT MODIFIED
SHORT TRACK TRUCK
STRAIGHT UP METAL
STREET STOCK
MD3 DIRT LATE MODEL
MD3 DIRT MODIFIED
DIRT GRAND NATIONAL
DRAG RACING
OFF ROAD
ROAD RACING
RACING WINDOWS
BODY ADD-ONS

ABC GREENHOUSE STYLE BODY ADD-ONS & ACCESSORIES



FIND ALL BODY ADD-ONS & ACCESSORIES // PGS 95-123



“Great appearance and detail.” -- BEN ROWE



ABC GREENHOUSE STYLE BODY



The GREENHOUSE STYLE BODY is very easy to mount! The 2-piece roof configuration offers several benefits over the traditional roof style. It's the only body to offer molded plastic quarter panels for the ULTIMATE DURABILITY & EQUAL AERODYNAMIC PERFORMANCE!

This 2-piece roof configuration offers several benefits over the traditional roof style and features mounting flanges with built in locating tabs to speed up mounting.

The rear greenhouse section is a unique configuration that includes integrated side window panels and a deck lid filler panel. The greenhouse body was designed to make quarter panel replacement quick and easy. Rear window installation is hassle free and the rear package tray makes mounting your interior panels a snap!

The greenhouse will fit all templates without hassle if mounted to proper height dimensions. Mount your own body using our Roof Locating Fixture for ease of installation in your own shop!

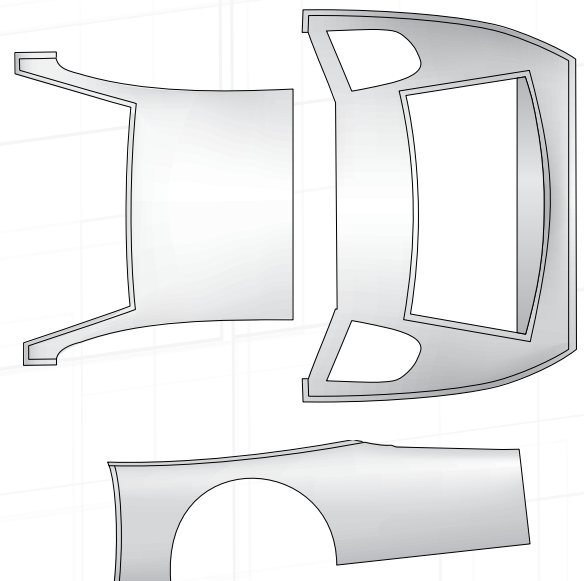

CHASSIS	ROOF HEIGHT	TREAD WIDTH	WHEELBASE
Offset/Straight Rail	47"	66" max	101-108"

Go to our downloads page at FIVESTARBODIES.com for complete body installation guidelines.

CHECK OUT WHY TOP TEAMS CHOOSE FIVE STAR!
www.FIVESTARBODIES.com/BETTERBODIES

BODY PACKAGES & OPTIONS

BODY PACKAGES

*Yellow composite body panels may be special order parts, contact Five Star for availability.

		PN		PN		
		-B	-W	-CB	-R	-Y
1	RE-SKIN PACKAGE Includes Aluminum Doors; High-Impact Molded Plastic Nose, Bumper Cover, Fenders, Quarter Panels & Rocker Panels	593-100-x	\$904	593-100-x	\$944	
2	PACKAGE A Includes Aluminum Doors, Deck Lid & Deck Lid Hold-down; High-Impact Molded Plastic Nose, Bumper Cover, Fenders, Quarter Panels & Rocker Panels; Standard Composite Hood, Front & Rear Greenhouse; Ultraglass Windshield Cowl Panel	593-112-x	\$1,874	593-112-x	\$1,959	
3	ECONOMY COMPLETE PACKAGE Includes Aluminum Doors, Deck Lid, Deck Lid Hold-down; High-Impact Molded Plastic Nose, Bumper Cover, Fenders, Quarter Panels & Rocker Panels; Standard Composite Hood, Front & Rear Greenhouse; Ultraglass Windshield Cowl Panel; 6½" 70° Unpainted Spoiler; Mar-Resistant Coated Windshield & Quarter Windows; Uncoated Rear Window	593-142-x	\$2,606	593-142-x	\$2,691	
4	ADVANCED LIGHTWEIGHT COMPOSITE PANEL PACKAGE Includes Aluminum Doors, Deck Lid & Deck Lid Hold-down; High-Impact Molded Plastic Nose, Bumper Cover, Rocker Panels; Advanced Lightweight Composite Hood, Front & Rear Greenhouse; Ultraglass Windshield Cowl Panel, Fenders, Quarter Panels; 6½" 70° Unpainted Spoiler; Mar-Resistant Coated Windshield & Quarter Windows; Uncoated Rear Window	593-152-x	\$3,424	593-152-x	\$3,649	

MUST SPECIFY THESE ITEMS WHEN ORDERING: Body Color (White -W; Black -B; Blue -CB; Red -R), Nose Style, Spoiler Size & Angle, Fender Size, Rocker Style

OPTIONS & UPGRADES	+/- FROM PKG \$	PKG	-B	-W	-CB	-R	-Y
Fenders, molded plastic, 8" tires REQUIRED FOR ACT SERIES		1,2,3	\$0		\$0		
Fenders, Ultraglass 10" tires		1,2,3	+\$66		+\$140		
Greenhouse, front advanced lightweight composite		2,3	+\$116		+\$105		
Greenhouse, rear, advanced lightweight composite		2,3	+\$249		+\$249		
Hood, advanced lightweight composite		2,3	+\$239		+\$236		
Quarter Panels, Ultraglass		1,2,3	+\$148		+\$228		
Rocker Panels, aluminum		1,2,3,4	+\$12		+\$7		
Spoiler, 5" x 60" x 1/4", 55°, 70°, 90°		3,4	\$0		\$0		
Spoiler Brackets, black powder-coated		3,4	+\$7		+\$7		
Windows, rear, mar-resistant coated		3,4	+\$114		+\$114		

ECONOMY WINDOW PACKAGE

Mar-Resistant Coated Windshield, Uncoated Rear (oversized-customer must trim to fit) & Quarter Windows, without black-out borders - \$134

NOTE: All windows are pre-cut-to-fit, beveled & drilled with permanent black-out border unless specified otherwise

DELUXE BODY MOUNTING KIT

EVERYTHING YOU NEED TO MOUNT YOUR NEW BODY!!



ALL NEW

SAVE 10%

BY PURCHASING A COMPLETE KIT vs. individual components!

- Body/Window & Nose Braces
- Universal Bracing Kits
- Front & Rear Bumpers
- Bumper Mounting Kits
- Right Side Door Support
- Nose & Tail ID Graphics
- Wear Strips & Attachment Kits
- Hood Pin Brackets & Pins
- Rear Deck Mounting Kit
- Nose Screen
- Vent Window
- Window Installation Kit

PN# 800-1D \$813

more info pg 101

VISIT OUR WEBSITE FOR BODY MOUNTING GUIDELINES, TEMPLATES AND MORE!

NEW LATE MODEL
ABC
LATE MODEL STOCK
NASCAR PRO SERIES
ARCA RACING SERIES
S2
PAVEMENT MODIFIED
SHORT TRACK TRUCK
STRAIGHT UP METAL
STREET STOCK
M3 DIRT LATE MODEL
M3 DIRT MODIFIED
DIRT GRAND NATIONAL
DRAG RACING
OFF ROAD
ROAD RACING
RACING WINDOWS
BODY ADD-ONS

ABC GREENHOUSE STYLE BODY PACKAGES & OPTIONS



REPLACEMENT PANELS FOR ABC GREENHOUSE BODIES

REPLACEMENT PANELS	-B	-W	RACER	-CB	-R	-Y	RACER	
Bumper Cover, rear, high-impact molded plastic			460-450-x	\$113			460-450-x	\$118
Cowl Panel w/Air Deflector & Air Insert, Ultraglass			671-5100-x	\$224			671-5100-x	\$232
Deck Lid, aluminum			661-310A-x	\$49			661-310A-x	\$49
Door, aluminum, Left or right			661-21A-xLorR	\$79			661-21A-xLorR	\$79
Fender, standard composite, for 8" tires			663-230-xLorR	\$124			n/a	n/a
Fender, high-impact molded plastic, for 8" tires <i>ACT SERIES</i>			660-23-xLorR	\$114			660-23-xLorR	\$119
Fender, Ultraglass, for 10" tires			663-240-xLorR	\$147			663-240-xLorR	\$189
Fender, high-impact molded plastic, for 10" tires			660-24-xLorR	\$114			660-24-xLorR	\$119
Greenhouse, Front, standard composite			671-5112-x	\$233			671-5112-x	\$249
Greenhouse, Front, advanced lightweight composite			671-5112L-x	\$349			671-5112L-x	\$354
Greenhouse, Rear, standard composite			671-5102-x	\$291			671-5102-x	\$304
Greenhouse, Rear, advanced lightweight composite			671-5102L-x	\$540			671-5102L-x	\$553
Hood, standard composite			670-3301-x	\$167			670-3301-x	\$175
Hood, standard composite (2½" scoop) <i>NOT ABC APPROVED</i>			660-3303-x	\$167			n/a	n/a
Hood, advanced lightweight composite			670-3301L-x	\$406			670-3301L-x	\$411
Quarter Panel, Ultraglass			673-270-xLorR	\$185			673-270-xLorR	\$230
Quarter Panel, high-impact molded plastic			670-27-xLorR	\$111			670-27-xLorR	\$116
Rocker Panel, aluminum, fits either side			000-5501A-x	\$42			000-5501A-x	\$42
Rocker Panel, molded plastic, fits either side			000-5501P-x	\$30			000-5501P-x	\$35
WINDOWS	PART #						RACER	
Quarter, mar-resistant coated, black-out border	460-6515BLorR						\$48	
Quarter, uncoated	460-6512LorR						\$35	
Rear, mar-resistant coated	574-6115-3						\$283	
Rear, mar-resistant coated, black-out border	574-6115-3B						\$305	
Rear, uncoated	574-6111-3						\$169	
Rear, uncoated, black-out border	574-6111-3B						\$191	
Rear, oversize, uncoated <i>FOR USE ON OTHER MANUFACTURERS BODIES</i>	324-6111-1						\$144	
Windshield, pre-cut to fit, 1/8"	564-6325-3						\$349	
Windshield, pre-cut to fit, black-out border, 1/8"	564-6325-3B						\$340	
Windshield, pre-cut to fit, black-out border, 3/16"	564-6335-3B						\$397	
Windshield, oversize, without black-out border, 1/8" <i>FOR USE ON OTHER MANUFACTURERS' BODIES</i>	564-6325-1						\$322	
NOSES	CHEVROLET	FORD	TOYOTA	DODGE	RACER			
Nose, plastic -B -W	660-410-x	570-410-x	720-410-x	470-410-x	\$123			
Nose, plastic -CB -R -Y	660-410-x	570-410-x	720-410-x	n/a	\$128			
SPOILERS: 60" WIDE	5" (90°)	5" (70°)	5" (55°)	6½" (90°)	6½" (70°)	6½" (55°)	RACER	
Complete, aluminum	661-6749	661-6747	661-6745	661-6739	661-6737	661-6735	\$105	
Complete, aluminum, black	661-6749-B	661-6747-B	661-6745-B	661-6739-B	661-6737-B	661-6735-B	\$112	
Brackets, aluminum	661-6739-1	661-6737-1	661-6735-1	661-6739-1	661-6737-1	661-6735-1	\$75	
Brackets, aluminum, black	661-6739-1B	661-6737-1B	661-6735-1B	661-6739-1B	661-6737-1B	661-6735-1B	\$82	
Blades, polycarbonate	661-6749-2	661-6747-2	661-6745-2	661-6739-2	661-6737-2	661-6735-2	\$30	
TEMPLATES	CHEVROLET	FORD	TOYOTA	DODGE	RACER			
Complete Set, wood	660-82	570-82	660-82	470-82	\$117			
<i>Complete Template set includes: Fenders; Nose Centerline; Body Centerline; Rear Roof side-to-side</i>								

*Yellow composite body panels may be special order parts, contact Five Star for availability.

ENHANCE YOUR BODY WITH THESE GREAT BODY ADD-ONS & ACCESSORIES



□ **WEAR STRIPS
ATTACH KITS**
..... pg 117

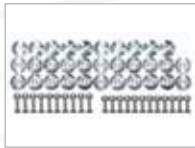

□ **SPOILER
MOUNTING KITS**
..... pg 105



□ **REAR DECK
MOUNTING KIT**
..... pg 106



□ **NOSE BRACES
TELESCOPING
BRACES**
..... pg 109-110

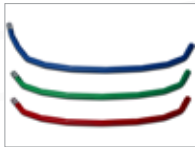

□ **BUMPERS
MOUNTING KITS**
..... pg 120



□ **DOOR VENT
WINDOWS**
..... pg 115

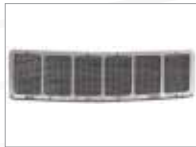

□ **NOSE
SCREENS**
..... pg 97



□ **HOOD PIN
BRACKETSKITS**
..... pg 118



□ **WINDOW
BRACES**
..... pg 111

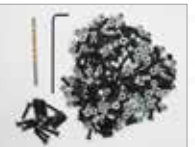

□ **WINDOW
INSTALL KITS**
..... pg 105



□ **HOOD PROPS
HOOD HINGES**
..... pg 119



□ **BODY
MOUNTING TABS**
..... pg 107



□ **BRAKE DUCTS
HOSES**
..... pg 115



□ **BACK-UP
PLATE KITS**
..... pg 111



□ **FIVE STAR
RIVETS/WASHERS**
..... pg 104



□ **DOOR
SUPPORT**
..... pg 107



□ **RACING
MIRRORS**
..... pg 114



□ **POLYCARBONATE
RUB RAILS**
..... pg 114



□ **BODY
BRACING**
..... pg 108



□ **QUARTER PANEL
BODY BRACES**
..... pg 109



□ **NOSE & TAIL GRAPHIC ID KITS**
..... pg 96



□ **SC1 DETAILER
SPEED WAX**
..... pg 123



□ **PLASTIC
PRIMER**
..... pg 122

FEATURED PRODUCTS

HOT TIP

PROFESSIONAL BODY INSTALLERS USE THESE PRODUCTS... YOU SHOULD TOO!

#1



DETAILS » PG 116

RADIATOR AIR DUCTS

**LIGHT WEIGHT &
BUILT TO LAST!**
Available in your choice of molded plastic or flexible!

#2



DETAILS » PG 112

COLD AIR BOXES

**PATENTED
FLOW DESIGN!**
Flow bench tested for peak air flow!!

#3



DETAILS » PG 106

ROOF LOCATING FIXTURE

**THE FASTEST,
EASIEST WAY**
to mount a body on your own!

#4



DETAILS » PG 122

WINDOW CLEANER

**MAXIMIZE
OPTICAL CLARITY**
in the most extreme conditions!

NEW LATE MODEL

ABC

LATE MODEL STOCK

NASCAR PRO SERIES

ARCA RACING SERIES

S2

PAVEMENT MODIFIED

SHORT TRACK TRUCK

STRAIGHT UP METAL

STREET STOCK

MD3 DIRT LATE MODEL

MD3 DIRT MODIFIED

DIRT GRAND NATIONAL

DRAG RACING

OFF ROAD

ROAD RACING

RACING WINDOWS

BODY ADD-ONS

ABC GREENHOUSE STYLE BODY ADD-ONS & ACCESSORIES



FIND ALL BODY ADD-ONS & ACCESSORIES // PGS 95-123



"You won't find a better quality body!" -- BUBBA POLLARD



ABC TRADITIONAL ROOF STYLE BODY

This is the ORIGINAL BODY CONFIGURATION. Many racers still prefer this style. The choice is yours! This body has a 1-piece roof with full quarter panels & a separate deck lid filler.

This body can be easily mounted to fit different applications! It has a 1-piece roof with separate full quarter panels and a deck lid filler. It will come close to fitting all templates without hassle if mounted to proper height dimensions.

Mount your own body using our Roof Locating Fixture for ease of installation in your own shop!

CHASSIS	ROOF HEIGHT	TREAD WIDTH	WHEELBASE
Offset/Straight Rail	47"	66" max	101-108"

Go to our downloads page at FIVESTARBODIES.com for complete body installation guidelines.

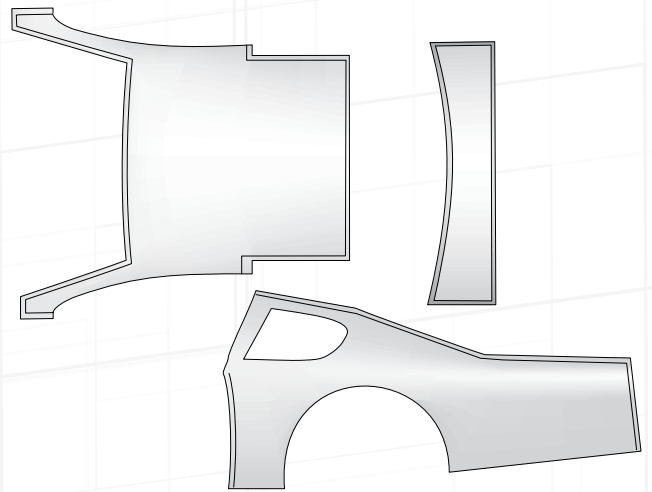

CHECK OUT WHY TOP TEAMS CHOOSE FIVE STAR!
www.FIVESTARBODIES.com/BETTERBODIES

BODY PACKAGES & OPTIONS

BODY PACKAGES

*Yellow composite body panels may be special order parts, contact Five Star for availability.

		PN -B -W		PN -CB -R -Y	
1	RE-SKIN PACKAGE Includes Aluminum Doors; High-Impact Molded Plastic Nose, Bumper Cover, Fenders, & Rocker Panels; Ultraglass Quarter Panels	583-100-x	\$1,194	583-100-x	\$1,286
2	PACKAGE A Includes Aluminum Doors, Deck Lid & Deck Lid Hold-down; High-Impact Molded Plastic Nose, Bumper Cover, Fenders & Rocker Panels; Standard Composite Hood & Roof; Ultraglass Windshield Cowl Panel, Quarter Panels & Deck Lid Filler	583-112-x	\$1,973	583-112-x	\$2,118
3	ECONOMY COMPLETE PACKAGE Includes Aluminum Doors, Deck Lid & Deck Lid Hold-down; High-Impact Molded Plastic Nose, Bumper Cover, Fenders & Rocker Panels; Standard Composite Hood & Roof; Ultraglass Windshield Cowl Panel, Quarter Panels & Deck Lid Filler; 6½" 70° Unpainted Spoiler; Mar-Resistant Coated Windshield & Quarter Windows; Uncoated Rear Window	583-142-x	\$2,705	583-142-x	\$2,850
4	ADVANCED LIGHTWEIGHT COMPOSITE PANEL PACKAGE Includes Aluminum Doors, Deck Lid & Deck Lid Hold-down; High-Impact Molded Plastic Nose, Bumper Cover & Rocker Panels; Advanced Lightweight Composite 1-piece Hood & Roof; Ultraglass Windshield Cowl Panel, Quarter Panels, Deck Lid Filler, Fenders; 6½" 70° Unpainted Spoiler; Mar-Resistant Coated Windshield & Quarter Windows; Uncoated Rear Window	583-152-x	\$3,184	583-152-x	\$3,381

MUST SPECIFY THESE ITEMS WHEN ORDERING: Body Color (White -W; Black -B; Blue -CB; Red -R), Nose Style, Spoiler Size & Angle, Fender Size, Rocker Style

BODY PACKAGE OPTIONS & UPGRADES +/- FROM PKG \$

	PKG	-B -W	-CB -R -Y
Fenders, plastic, 8" tires (REQUIRED FOR ACT SERIES)	1,2,3	\$0	\$0
Fenders, Ultraglass 10" tires	1,2,3	+\$66	+\$140
Hood, advanced lightweight composite	2,3	+\$239	+\$236
Rocker Panels, aluminum	1,2,3,4	+\$12	+\$7
Roof, advanced lightweight composite	2,3	+\$174	+\$155
Spoiler, 5" x 60" x 1/4"; 55°, 70° or 90°	3,4	\$0	\$0
Spoiler Brackets, black powder-coated	3,4	+\$7	+\$7
Windows, rear, mar-resistant coated	3,4	+\$114	+\$114

ECONOMY WINDOW PACKAGE

Mar-Resistant Coated Windshield, Uncoated Rear (oversized: customer must trim to fit) & Quarter Windows, without black-out borders - \$134

NOTE: All windows are pre-cut-to-fit, beveled & drilled with permanent black-out border unless specified otherwise

DELUXE BODY MOUNTING KIT

EVERYTHING YOU NEED TO MOUNT YOUR NEW BODY!!



ALL NEW

SAVE 10%

BY PURCHASING A COMPLETE KIT vs. individual components!

- Body/Window & Nose Braces
- Universal Bracing Kits
- Front & Rear Bumpers
- Bumper Mounting Kits
- Right Side Door Support
- Nose & Tail ID Graphics
- Wear Strips & Attachment Kits
- Hood Pin Brackets & Pins
- Rear Deck Mounting Kit
- Nose Screen
- Vent Window
- Window Installation Kit

PN# 800-1D \$813

more info pg 101

VISIT OUR WEBSITE FOR BODY MOUNTING GUIDELINES, TEMPLATES AND MORE!

NEW LATE MODEL

ABC

LATE MODEL STOCK

NASCAR PRO SERIES

ARCA RACING SERIES

S2

PAVEMENT MODIFIED

SHORT TRACK TRUCK

STRAIGHT UP METAL

STREET STOCK

MD3 DIRT LATE MODEL

MD3 DIRT MODIFIED

DIRT GRAND NATIONAL

DRAG RACING

OFF ROAD

ROAD RACING

RACING WINDOWS

BODY ADD-ONS

ABC TRADITIONAL ROOF BODY PACKAGES & OPTIONS



REPLACEMENT PANELS FOR ABC TRADITIONAL ROOF BODIES

REPLACEMENT PANELS	-B	-W	RACER	-CB	-R	-Y	RACER
Bumper Cover, rear, high-impact molded plastic			460-450-x				\$113
Cowl Panel w/Air Deflector & Air Insert, Ultraglass			671-5100-x				\$224
Deck Lid, aluminum			661-310A-x				\$49
Deck Lid Filler Panel, Ultraglass			661-3200-x				\$99
Door, aluminum, left or right			661-21A-xLorR				\$79
Fender, standard composite, for 8" tires			663-230-xLorR				\$124
Fender, high-impact molded plastic, for 8" tires ACT SERIES			660-23-xLorR				\$114
Fender, Ultraglass, for 10" tires			663-240-xLorR				\$147
Fender, high-impact molded plastic, for 10" tires			660-24-xLorR				\$114
Hood, standard composite			670-3301-x				\$167
Hood, standard composite (2½" scoop) NOT ABC APPROVED			660-3303-x				\$167
Hood, advanced lightweight composite			670-3301L-x				\$406
Quarter Panel, Ultraglass, left or right			463-270-xLorR				\$256
Rocker Panel, aluminum, fits either side			000-5501A-x				\$42
Rocker Panel, high-impact molded plastic, fits either side			000-5501P-x				\$30
Roof, standard composite			661-5102-x				\$234
Roof, advanced lightweight composite			661-5102L-x				\$408

WINDOWS	PART #	RACER
Quarter, mar-resistant coated, black-out border	460-6515BLorR	\$48
Quarter, uncoated	460-6512LorR	\$35
Rear, mar-resistant coated	574-6115-3	\$283
Rear, mar-resistant coated, black-out border	574-6115-3B	\$305
Rear, uncoated	574-6111-3	\$169
Rear, uncoated, black-out border	574-6111-3B	\$191
Rear, oversize, uncoated FOR USE ON OTHER MANUFACTURER'S BODIES	324-6111-1	\$144
Windshield, pre-cut to fit, 1/8"	564-6325-3	\$349
Windshield, pre-cut to fit, black-out border, 1/8"	564-6325-3B	\$340
Windshield, pre-cut to fit, black-out border, 3/16"	564-6335-3B	\$397
Windshield, oversize, with out black-out border, 1/8" FOR USE ON OTHER MANUFACTURER'S BODIES	564-6325-1	\$322

NOSES	CHEVROLET	FORD	TOYOTA	DODGE	RACER
Nose, plastic -B -W	660-410-x	570-410-x	720-410-x	470-410-x	\$123
Nose, plastic -CB -R -Y	660-410-x	570-410-x	720-410-x	n/a	\$128

SPOILERS: 60" WIDE	5" (90°)	5" (70°)	5" (55°)	6½" (90°)	6½" (70°)	6½" (55°)	RACER
Complete, aluminum	661-6749	661-6747	661-6745	661-6739	661-6737	661-6735	\$105
Complete, aluminum, black	661-6749-B	661-6747-B	661-6745-B	661-6739-B	661-6737-B	661-6735-B	\$112
Brackets, aluminum	661-6739-1	661-6737-1	661-6735-1	661-6739-1	661-6737-1	661-6735-1	\$75
Brackets, aluminum, black	661-6739-1B	661-6737-1B	661-6735-1B	661-6739-1B	661-6737-1B	661-6735-1B	\$82
Blades, polycarbonate	661-6749-2	661-6747-2	661-6745-2	661-6739-2	661-6737-2	661-6735-2	\$30

TEMPLATES	CHEVROLET	FORD	TOYOTA	DODGE	RACER
Complete Set, wood	660-82	570-82	660-82	470-82	\$117

Complete Template set includes: Fenders; Nose Centerline; Body Centerline; Rear Roof side-to-side

*Yellow composite body panels may be special order parts, contact Five Star for availability.

ENHANCE YOUR BODY WITH THESE GREAT BODY ADD-ONS & ACCESSORIES



□ **WEAR STRIPS
ATTACH KITS**
..... pg 117

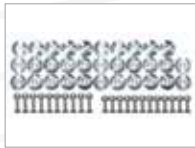

□ **SPOILER
MOUNTING KITS**
..... pg 105



□ **REAR DECK
MOUNTING KIT**
..... pg 106



□ **NOSE BRACES
TELESCOPING
BRACES**
..... pg 109-110

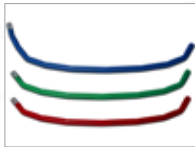

□ **BUMPERS
MOUNTING KITS**
..... pg 120



□ **DOOR VENT
WINDOWS**
..... pg 115

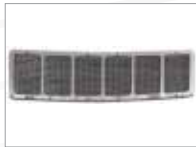

□ **NOSE
SCREENS**
..... pg 97



□ **HOOD PIN
BRACKETSKITS**
..... pg 118



□ **WINDOW
BRACES**
..... pg 111

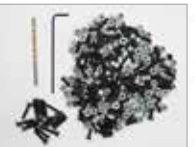

□ **WINDOW
INSTALL KITS**
..... pg 105



□ **HOOD PROPS
HOOD HINGES**
..... pg 119



□ **BODY
MOUNTING TABS**
..... pg 107



□ **BRAKE DUCTS
HOSES**
..... pg 115



□ **BACK-UP
PLATE KITS**
..... pg 111



□ **FIVE STAR
RIVETS/WASHERS**
..... pg 104



□ **DOOR
SUPPORT**
..... pg 107



□ **RACING
MIRRORS**
..... pg 114



□ **POLYCARBONATE
RUB RAILS**
..... pg 114



□ **BODY
BRACING**
..... pg 108

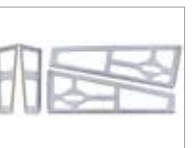

□ **QUARTER PANEL
BODY BRACES**
..... pg 109



□ **NOSE & TAIL GRAPHIC ID KITS**
..... pg 96



□ **SC1 DETAILER
SPEED WAX**
..... pg 123



□ **PLASTIC
PRIMER**
..... pg 122

FEATURED PRODUCTS

HOT TIP

PROFESSIONAL BODY INSTALLERS USE THESE PRODUCTS... YOU SHOULD TOO!

#1



DETAILS » PG 116

RADIATOR AIR DUCTS

LIGHT WEIGHT & BUILT TO LAST!
Available in your choice of molded plastic or flexible!

#2



DETAILS » PG 112

COLD AIR BOXES

PATENTED FLOW DESIGN!
Flow bench tested for peak air flow!!

#3



DETAILS » PG 106

ROOF LOCATING FIXTURE

THE FASTEST, EASIEST WAY
to mount a body on your own!

#4



DETAILS » PG 122

WINDOW CLEANER

MAXIMIZE OPTICAL CLARITY
in the most extreme conditions!

NEW LATE MODEL

ABC

LATE MODEL STOCK

NASCAR PRO SERIES

ARCA RACING SERIES

S2

PAVEMENT MODIFIED

SHORT TRACK TRUCK

STRAIGHT UP METAL

STREET STOCK

MD3 DIRT LATE MODEL

MD3 DIRT MODIFIED

DIRT GRAND NATIONAL

DRAG RACING

OFF ROAD

ROAD RACING

RACING WINDOWS

BODY ADD-ONS

ABC TRADITIONAL ROOF BODY ADD-ONS & ACCESSORIES



FIND ALL BODY ADD-ONS & ACCESSORIES // PGS 95-123



PHILLIP MORRIS
LATE MODEL STOCK CAR CHAMPION



LATE MODEL STOCK CAR BODIES

THE EASIEST LMSC BODY TO INSTALL. The 2-piece roof configuration offers several benefits over other styles. The only Late Model Stock body to offer optional High-Impact Molded Plastic Quarter Panels for the ultimate durability!

The 2-piece configuration features mounting flanges with built in locating tabs to speed up mounting. The greenhouse will fit all templates without hassle if mounted to proper height dimensions.

The rear greenhouse section is a unique configuration that includes integrated side window panels and deck lid filler panel. Rear window installation is quick and hassle free!

This is the only Late Model Stock body to feature optional High-Impact Molded Plastic Quarter Panels for superior durability. They have a longer life than fiberglass with equal aerodynamic performance.

Mount your own body using our Roof Locating Fixture for ease of installation in your own shop!



CHASSIS	ROOF HEIGHT	TREAD WIDTH	WHEELBASE
LMSC Perimeter	48"	up to 64 1/2"	up to 106" High-Impact Molded Plastic Fenders; 108" Ultraglass Fenders

Go to our downloads page at FIVESTARBODIES.com for complete body installation guidelines.

CHECK OUT WHY TOP TEAMS CHOOSE FIVE STAR!
www.FIVESTARBODIES.com/BETTERBODIES

BODY PACKAGES & OPTIONS

BODY PACKAGES

*Yellow composite body panels may be special order parts, contact Five Star for availability.

		PN		PN		
		-B	-W	-CB	-R	-Y
1	RE-SKIN PACKAGE Includes Aluminum Doors; High-Impact Molded Plastic Nose, Bumper Cover & Rocker Panels; Ultraglass Fenders & Quarter Panels	592-100-x	\$1,118	592-100-x	\$1,312	
2	PACKAGE A Includes Aluminum Doors, Deck Lid & Deck Lid Hold-down; High-Impact Molded Plastic Nose, Bumper Cover & Rocker Panels; Standard Composite Hood; Ultraglass Fenders, Quarter Panels, Front & Rear Greenhouse	592-112-x	\$2,006	592-112-x	\$2,263	
3	ECONOMY COMPLETE PACKAGE Includes Aluminum Doors, Deck Lid & Deck Lid Hold-down; High-Impact Molded Plastic Nose, Bumper Cover & Rocker Panels; Standard Composite Hood; Ultraglass Fenders, Quarter Panels, Front & Rear Greenhouse; 5" 55° Unpainted 1/8" Aluminum Spoiler; Mar-Resistant Coated Windshield & Quarter Windows, Uncoated Rear Window	592-142-x	\$2,725	592-142-x	\$2,982	

MUST SPECIFY THESE ITEMS WHEN ORDERING: Body Color (White -W; Black -B; Blue -CB; Red -R), Nose Style, Spoiler Size & Angle, Fender Size, Rocker Style

BODY PACKAGE OPTIONS & UPGRADES +/- FROM PKG \$

	PKG	-B	-W	-CB	-R	-Y
Fenders, high-impact molded plastic	1,2,3	-\$66		-\$140		
Quarter Panel, high-impact molded plastic	2,3	-\$148		n/a		
Hood, oversize, advanced lightweight composite	2,3	+\$239		n/a		
Rocker Panels, aluminum	1,2,3	+\$12		+\$7		
Rocker Panels, wrap around lower area, aluminum	1,2,3	+\$38		+\$28		
Spoiler, polycarbonate, 5" x 54" x 1/4", 55°	3	+\$13		+\$13		
Spoiler, aluminum, black powder-coated 5" x 54" x 1/8", 55°	3	+\$4		+\$4		
Spoiler Brackets, black powder-coated	3	+\$20		+\$20		
Windows, rear, mar-resistant coated	3	+\$114		+\$114		
Windows, without black-out (uncoated quarters)	3	-\$84		-\$84		

ECONOMY WINDOW PACKAGE

Mar-Resistant Coated Windshield, Uncoated Rear (oversized-customer must trim to fit) & Quarter Windows, without black-out borders - \$134

NOTE: All windows are pre-cut-to-fit, beveled & drilled with permanent black-out border unless specified otherwise.

DELUXE BODY MOUNTING KIT

EVERYTHING YOU NEED TO MOUNT YOUR NEW BODY!!



ALL NEW

SAVE 10%

BY PURCHASING A COMPLETE KIT vs. individual components!

- Body/Window & Nose Braces
- Universal Bracing Kits
- Front & Rear Bumpers
- Bumper Mounting Kits
- Nose & Tail ID Graphics
- Wear Strips & Attachment Kits
- Hood Pin Brackets & Pins
- Rear Deck Mounting Kit
- Nose Screen
- Vent Window
- Window Installation Kit

PN# 800-3D \$750

more info pg 102

NEW LATE MODEL
ABC
LATE MODEL STOCK
NASCAR PRO SERIES
ARCA RACING SERIES
S2
PAVEMENT MODIFIED
SHORT TRACK TRUCK
STRAIGHT UP METAL
STREET STOCK
M3 DIRT LATE MODEL
M3 DIRT MODIFIED
DIRT GRAND NATIONAL
DRAG RACING
OFF ROAD
ROAD RACING
RACING WINDOWS
BODY ADD-ONS

LATE MODEL STOCK CAR BODY PACKAGES & OPTIONS



REPLACEMENT PANELS FOR LATE MODEL STOCK BODIES

REPLACEMENT PANELS	-B	-W	RACER	-CB	-R	-Y	RACER	
Bumper Cover, rear, plastic			672-450-x	\$113			672-450-x	\$118
Deck Lid, aluminum			661-310A-x	\$49			661-310A-x	\$49
Door, aluminum, for wide clearance fenders, left or right			672-22A-xLorR	\$79			672-22A-xLorR	\$79
Fender, high-impact molded plastic, high clearance, left or right			662-24-xLorR	\$114			662-24-xLorR	\$119
Fender, Ultraglass, high clearance, left or right			672-240-xLorR	\$147			672-240-xLorR	\$189
Greenhouse, Front, Ultraglass			672-5112-x	\$316			672-5112-x	\$328
Greenhouse, Rear, Ultraglass			592-5102-x	\$350			592-5102-x	\$393
Hood, standard size, standard composite, flat			672-3301-x	\$167			672-3301-x	\$175
Hood, oversize, advanced lightweight composite, flat			672-3302L-x	\$406			n/a	n/a
Quarter Panel, Ultraglass, left or right			672-271-xLorR	\$185			672-271-xLorR	\$230
Rocker Panel, aluminum, fits either side			000-5501A-x	\$42			000-5501A-x	\$42
Rocker Panel, high-impact molded plastic, fits either side			000-5501P-x	\$30			000-5501P-x	\$35
Rocker Panel, wraparound lower area, aluminum			000-5503A-x	\$44			000-5503A-x	\$48

OLDER STYLE COMPONENTS						
Bumper Cover, rear, plastic, repl, for 672-270 quarters			460-450-x	\$113	460-450-x	\$118
Quarter Panel, repl., use w/460-450, composite, left or right			672-270-xLorR	\$168	n/a	n/a
Quarter Panel, repl., use w/460-450, plastic, left or right			672-27-xLorR	\$111	n/a	n/a

WINDOWS			PART #	RACER
Quarter, molded, mar-resistant coated, black-out border			460-6515BLorR	\$48
Quarter, molded, uncoated, pre-cut to fit			460-6512LorR	\$35
Quarter, pair, flat, uncoated, trimmed			460-6502	\$33
Rear, mar-resistant coated, oversize <i>FITS ALL LMSC BODIES</i>			564-6115-1	\$289
Rear, mar-resistant coated, pre-cut to fit			674-6115-2	\$283
Rear, mar-resistant coated, pre-cut to fit, black-out			674-6115-2B	\$305
Rear, uncoated, oversize <i>FITS ALL LMSC BODIES</i>			324-6111-1	\$144
Rear, uncoated, pre-cut to fit			674-6111-2	\$169
Rear, uncoated, pre-cut to fit, black-out border			674-6111-2B	\$191
Windshield, oversize <i>FITS ALL LMSC BODIES</i>			564-6325-1	\$322
Windshield, pre-cut to fit			674-6325-2	\$312
Windshield, pre-cut to fit, black-out border			674-6325-2B	\$340
Windshield, pre-cut to fit, 3/16"			674-6335-2	\$369

NOSES	CHEVROLET	FORD	TOYOTA	DODGE	RACER
Nose, plastic -B -W	660-410-x	570-410-x	720-410-x	470-410-x	\$123
Nose, plastic -CB -R -Y	660-410-x	570-410-x	720-410-x	n/a	\$128

SPOILERS: 60" WIDE	UNPAINTED	RACER	BLACK	RACER
Aluminum (standard) 5" x 54", 55° 1/8" thick	672-6715	\$92	672-6715-B	\$103
Polycarbonate (optional) 5" x 54", 55° 1/4" thick	672-6735	\$105	672-6735-B	\$112

TEMPLATES	CHEVROLET	FORD	TOYOTA	RACER
Complete Set, wood	672-82	592-82	672-82	\$174

Complete Template set includes: Fenders, Nose Centerline, Nose side-to-side, Body Centerline, Rear Window, Rear Roof side-to-side. Must ship truck freight.

*Yellow composite body panels may be special order parts, contact Five Star for availability.

ENHANCE YOUR BODY WITH THESE GREAT BODY ADD-ONS & ACCESSORIES



□ **WEAR STRIPS**
□ **ATTACH KITS**
.....pg 117

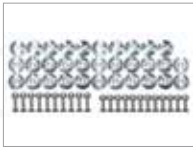

□ **SPOILER MOUNTING KITS**
..... pg 105



□ **REAR DECK MOUNTING KIT**
.....pg 106



□ **NOSE BRACES**
□ **TELESCOPING BRACES**
..... pg 109-110

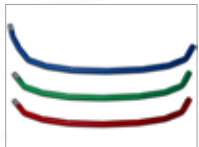

□ **BUMPERS**
□ **MOUNTING KITS**
..... pg 120



□ **DOOR VENT WINDOWS**
..... pg 115

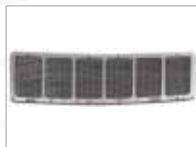

□ **NOSE SCREENS**
..... pg 97



□ **HOOD PIN BRACKETS & KITS**
..... pg 118



□ **WINDOW BRACES**
..... pg 111

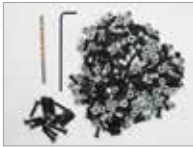

□ **WINDOW INSTALL KITS**
..... pg 105



□ **HOOD PROPS**
□ **HOOD HINGES**
..... pg 119



□ **BODY MOUNTING TABS**
..... pg 107



□ **BRAKE DUCTS**
□ **HOSES**
..... pg 115



□ **BACK-UP PLATE KITS**
..... pg 11



□ **NOSE & TAIL GRAPHIC ID KITS**
..... pg 96



□ **RACING MIRRORS**
..... pg 114



□ **POLYCARBONATE RUB RAILS**
..... pg 114



□ **BODY BRACING**
..... pg 108



□ **QUARTER PANEL BODY BRACES**
..... pg 109



□ **SC1 DETAILER**
□ **SPEED WAX**
..... pg 123



□ **PLASTIC PRIMER**
..... pg 122

FEATURED PRODUCTS

HOT TIP

PROFESSIONAL BODY INSTALLERS USE THESE PRODUCTS...YOU SHOULD TOO!

#1



DETAILS » PG 116

RADIATOR AIR DUCTS

LIGHT WEIGHT & BUILT TO LAST!
Available in your choice of molded plastic or flexible!

#2



DETAILS » PG 104

RIVETS & WASHERS

EXCLUSIVE FIVE STAR BRAND

Rivets are on the best on the market!

#3



DETAILS » PG 106

ROOF LOCATING FIXTURE

THE FASTEST, EASIEST WAY to mount a body on your own!

#4



DETAILS » PG 122

WINDOW CLEANER

MAXIMIZE OPTICAL CLARITY in the most extreme conditions!

NEW LATE MODEL

LATE MODEL STOCK

LATE MODEL STOCK

NASCAR PRO SERIES

ARCA RACING SERIES

S2

PAVEMENT MODIFIED

SHORT TRACK TRUCK

STRAIGHT UP METAL

STREET STOCK

MD3 DIRT LATE MODEL

MD3 DIRT MODIFIED

DIRT GRAND NATIONAL

DRAG RACING

OFF ROAD

ROAD RACING

RACING WINDOWS

BODY ADD-ONS

LATE MODEL STOCK CAR BODY ADD-ONS & ACCESSORIES



FIND ALL BODY ADD-ONS & ACCESSORIES // PGS 95-123



SHELDON CREED
ARCA Racing Series Champion



NASCAR K&N PRO SERIES/ARCA RACING SERIES

These bodies come complete and are designed for ease of installation by race teams, cutting labor costs for body maintenance and repair by up to 50% throughout the season!

APPROVED
FOR USE
IN:



AERODYNAMIC > LIGHT WEIGHT > DURABLE

- » Zero deflection at 200+mph race speeds
- » Excellent aero performance engineered through extensive wind tunnel testing
- » Withstands impact under normal racing conditions and will not leave debris on the track

WILL CUT LABOR COSTS

- » Reduces costs for body maintenance and repair by up to 50% throughout the season

EASY TO INSTALL

- » Body is divided into (12) separate flange fit panels
- » (10) mounting tabs are laminated into the greenhouse

BUILT FOR DRIVER SAFETY

- » Flame retardant body panels
- » Exclusive Five Star Safety Tether System built into the hood



DEREK KRAUS
NASCAR K+N West

CHECK OUT WHY TOP TEAMS CHOOSE FIVE STAR!
www.FIVESTARBODIES.COM/BETTERBODIES

BODY PACKAGES & OPTIONS

BODY PACKAGES

	CHEVROLET	FORD	TOYOTA
1 COMPLETE PACKAGE Includes Advanced Lightweight Composite Doors, Deck Lid, Deck Lid Extension, Nose, Bumper Cover, Hood, 1-piece Greenhouse Section, Fenders & Quarter Panels; Mar-Resistant Coated Windshield, Quarter Windows & Rear Window	14121-106 \$8,093	14311-106 \$7,920	14711-106 \$7,920

BODY PACKAGE OPTIONS & UPGRADES +/- FROM PKG \$

	CHEVROLET	FORD	TOYOTA
Hood, speedway, including flaps, composite	+\$172	+\$168	+\$168
Quarter Panels for 105" wheelbase, composite K&N SERIES ONLY	\$0	\$0	\$0

UNIVERSAL REPLACEMENT PANELS

	CHEVROLET	RACER	FORD	RACER	TOYOTA	RACER
Deck Lid, composite	14001-31011	\$709	14001-31011	\$709	14001-31011	\$709
Deck Lid Extension, composite	14121-32211	\$199	14311-32211	\$194	14711-32211	\$194
Door, composite, left or right	14121-21011LorR	\$325	14311-21011LorR	\$317	14711-21011LorR	\$317
Fender, composite, left or right	14121-23011LorR	\$323	14311-23011LorR	\$314	14711-23011LorR	\$314
Greenhouse, 1-piece, composite	14121-51212	\$1,934	14311-51212	\$1,883	14711-51212	\$1,883
Greenhouse with Flap Recesses, 1-piece, composite	14121-51222	\$1,978	14311-51222	\$1,923	14711-51222	\$1,923
Roof Flap Assembly, Universal, 1-piece, drop-in ready	14001-51881	\$2,270	14001-51881	\$2,270	14001-51881	\$2,270
Hood, flat, lightweight composite	14121-33012	\$852	14311-33012	\$829	14711-33012	\$829
Hood, speedway, w/flap openings, ltwt. composite	14121-33312	\$898	14311-33312	\$873	14711-33312	\$873
Hood Flap, lightweight composite, left or right	14121-34512LorR	\$63	14311-34512LorR	\$62	14711-34512LorR	\$62
Nose, composite	14121-41011	\$787	14311-41011	\$766	14711-41011	\$766
Quarter Panel for 110" wheelbase, composite, left or right	14121-27411LorR	\$423	14311-27411LorR	\$411	14711-27411LorR	\$411
Rear Bumper Cover, composite	14121-45011	\$567	14311-45011	\$552	14711-45011	\$552
Spoiler Blade, 3/16", 1-piece aluminum	14001-67033	\$79	14001-67033	\$79	14001-67033	\$79

K&N REPLACEMENT PANELS

	CHEVROLET	RACER	FORD	RACER	TOYOTA	RACER
Quarter Panel, 105" wheelbase, composite, left or right	14121-27311LorR	\$423	14311-27311LorR	\$411	14711-27311LorR	\$411

WINDOWS

	CHEVROLET	RACER	FORD	RACER	TOYOTA	RACER
Door, 1/4", mar-resistant coated, right ARCA SERIES ONLY	14001-62342R	\$73	14001-62342R	\$73	14001-62342R	\$73
Quarter, 3/16", mar-resistant coated, left or right	14121-65353LorR	\$86	14311-65353LorR	\$86	14711-65353LorR	\$86
Rear, 3/16", mar-resistant coated	14121-61353	\$339	14311-61353	\$339	14711-61353	\$339
Windshield, 1/4", mar-resistant coated	14121-63443	\$392	14311-63443	\$392	14711-63443	\$392
Windshield, laminated, 1/4", mar-resistant coated	14121-63443-2	\$895	14311-63443-2	\$895	14711-63443-2	\$895
Window Track, right side, composite ARCA SERIES ONLY	14001-76212	\$109	14001-76212	\$109	14001-76212	\$109

NOTE: All windows are pre-cut-to-fit, beveled & drilled with permanent black-out border unless specified otherwise.

SAVE COST! REPAIR...DON'T REPLACE!

FIVE STAR DAMAGED PANEL REPAIR PROGRAM & DIY REPAIR KIT

➤ Factory structural repairs are available for the following panels: **Hoods, Noses, Bumper Covers, Quarter Panels, Greenhouses and Deck Lids**

➤ Visit our website: **FIVESTARBODIES.COM** or contact a Five Star Rep for more details!



➤ This **FIVE STAR EXCLUSIVE KIT** is specially designed to work with our blends of fiberglass composites!

➤ **KIT INCLUDES ENOUGH MATERIALS TO MAKE MULTIPLE COSMETIC & MINOR STRUCTURAL REPAIRS!**

➤ **CONTENTS:** (1) quart of epoxy resin, hardener, 4' x 4½' of woven fiberglass mat, 4' x 4½' of Kevlar Material, (3) application brushes, (3) mixing cups and (10) disposable gloves!

➤ PN: 00001-91110 / \$147

VISIT OUR WEBSITE FOR BODY MOUNTING GUIDELINES, TEMPLATES AND MORE!

NEW LATE MODEL

ABC

NASCAR PRO SERIES

ARCA RACING SERIES

ARCA RACING SERIES

S2

PAVEMENT MODIFIED

SHORT TRACK TRUCK

STRAIGHT UP METAL

STREET STOCK

MD3 DIRT LATE MODEL

MD3 DIRT MODIFIED

DIRT GRAND NATIONAL

DRAG RACING

OFF ROAD

ROAD RACING

RACING WINDOWS

BODY ADD-ONS

NASCAR K&N / ARCA RACING SERIES BODY PACKAGES

ENHANCE YOUR BODY WITH THESE GREAT BODY ADD-ONS & ACCESSORIES

ADVANCED LIGHTWEIGHT COMPOSITE COWL INDUCTION KITS

SAVE ON TIME & LABOR COST WITH A COMPLETE KIT!

- Fits standard 14" filter element
- Quick and easy installation with "drop-in ready" parts
- This kit will save you hours of time and labor costs over a custom-fabricated unit!
- **FLOW BENCH TESTED COWL INDUCTION SYSTEMS FOR PEAK AIR FLOW!!**
- Ultra light weight, strong and durable composite construction
- Kits Include:
 - (1) Cold Air Box bottom (choose from 4 configurations)
 - (1) Universal Cold Air Box lid
 - (1) Universal Air Deflector
 - (1) Universal Air Inlet Insert
- **COMPLETE KIT: \$649.00**



Cowl Air Insert
14001-52301

Cowl Air Deflector
14001-52701

PART #		RACER
14001-53001	Cold Air Box, 4 bbl, lid, universal	\$164
14001-53431	Cold Air Box, 4 bbl, 3° angle, ARCA	\$284
14001-53461	Cold Air Box, 4 bbl, 6° angle, ARCA	\$284
14001-53432	Cold Air Box, 4 bbl, 3° angle, K&N	\$284
14001-53462	Cold Air Box, 4 bbl, 6° angle, K&N	\$284
14001-52701	Cowl Air Deflector, universal	\$105
14001-52301	Cowl Air Insert, universal	\$96

ADVANCED LIGHTWEIGHT COMPOSITE NOSE AIR INLET BEZEL & AIR INLET CLOSE-OUT

- Mounts to radiator opening on nose
- Used to cut out openings for desired airflow
- Designed to make grill and duct work installations easy!

PART #		RACER
14121-46611	Close-out, Chevrolet	\$118
14311-46611	Close-out, Ford	\$106
14711-46611	Close-out, Toyota	\$118
14311-46712	Air Inlet Bezel, Ford	\$156
14711-46712	Air Inlet Bezel, Toyota	\$133



Chevrolet Close-out
14121-46611

Ford Close-out
14311-46611



Toyota Close-out
14711-46611

POLYCARBONATE NOSE PROTECTOR

- Got a flat? Help protect, and save the lower flange of your nose!

PART #		RACER
14001-41851	Nose Protector, pair	\$84



PLASTIC UPPER GRILL

- Made of ultra-durable light weight plastic!
- Weighs only 1.2 lbs!

PART #		RACER
14311-46851	Ford, plastic	\$110



PLASTIC WEAR STRIPS

PROTECT THE LOWER EDGE OF YOUR NOSE IN STYLE!

- Helps to seal the nose to the race track to optimize aerodynamics
- Ready to install with Five Star's Wear Strip Attach Kit
- Available in (6) colors! -B -CB -R -W -Y -O

PART #		RACER
14001-41551-x	standard, pair	\$30
14001-41651-BorW	tall, pair (B&W only)	\$38



LIGHTWEIGHT ALUMINUM WEAR STRIP ATTACH KITS

ALL THE HARDWARE YOU NEED TO INSTALL WEAR STRIPS!

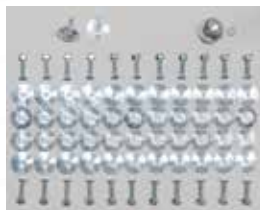

- Each kit includes light weight aluminum machined washers

PART #		RACER
000-400K	25 sets (full installation)	\$57
000-400K10	10 sets (replace (1) wear strip)	\$27

VISIT OUR WEBSITE FOR BODY MOUNTING GUIDELINES, TEMPLATES AND MORE!
*PRICES & PART NUMBERS SUBJECT TO CHANGE WITHOUT NOTICE.

ENHANCE YOUR BODY WITH THESE GREAT BODY ADD-ONS & ACCESSORIES

FORMED STEEL FRONT BUMPERS

EXACTLY CONTOURED TO THE
INSIDES OF OUR PLASTIC NOSES
FOR MAXIMUM PROTECTION!

- Formed from round .083" steel tubing with a finished appearance and easy to install!

PART #		RACER
14121-7116	Chevrolet, .083" steel	\$82.50
14311-7116	Ford, .083" steel	\$82.50
14711-7116	Toyota, .083" steel	\$82.50

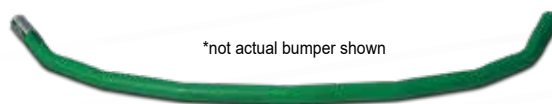

LIGHTWEIGHT ALUMINUM WINDOW BRACES

SLOTTED SUPPORT FLANGE SAVES WEIGHT
AND PROVIDES A CLEAN LOOK

- Designed to the exact contour of your windows and mounting hardware
- Made of premium high strength, ultra-strong light weight aluminum
- Weigh less than 2 lbs!
- Low gloss powder-coat finish
- Foam-padded surface won't mar window
- Pre-drilled holes to mount adjustable bracing from the interior for added support to window
- Kit Includes: (3) CNC-machined aluminum braces

PART #		RACER
14121-76133-3	Rear, Chevrolet	\$57
14311-76133-3	Rear, Ford	\$57
14711-76133-3	Rear, Toyota	\$57
14121-76333-3	Front, Chevrolet	\$57
14311-76333-3	Front, Ford	\$57
14711-76333-3	Front, Toyota	\$57

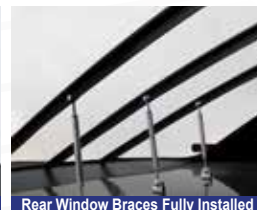

POLYCARBONATE REAR AIR DEFLECTOR

- Also known as a "Sharkfin"
- Comes as a 2-piece Polycarbonate set
- Weighs only 2 lbs!

PART #		RACER
14001-69400	2-piece set	\$58



VINYL NOSE & TAIL GRAPHIC ID KITS

GET THE OEM LOOK WITH OUTSTANDING REALISTIC DETAILS DESIGNED FOR ALL MAJOR MANUFACTURERS!

- ▶ Printed on 6-year outdoor durable high tack vinyl with aggressive adhesive
- ▶ Glossy laminated surface provides excellent sandblast and chemical protection!

PART #		RACER
14121-44141	Nose ID, Chevrolet SS	\$42
14121-44541	Tail ID, Chevrolet SS	\$25
14311-44141	Nose ID, Ford Fusion	\$24
14311-44541	Tail ID, Ford Fusion	\$25
14711-44141	Nose ID, Toyota Camry	\$38
14711-44541	Tail ID, Toyota Camry	\$25



HIGH-IMPACT MOLDED PLASTIC ROCKER PANELS

- ▶ Fit either side and easy to mount!
- ▶ Available in (6) colors! **-B** **-CB** **-R** **-W** **-Y** **-O**

PART #		RACER
14001-55051-x	each	\$19



FIVE STAR EXCLUSIVE LAMINATED WINDOWS



A SAFER WINDOW FOR DRIVERS!

- ▶ Deflects heavy impact for better driver safety
- ▶ Similar thickness to monolithic (single-layer) polycarbonate windows
- ▶ The BEST OPTICAL QUALITY available
- ▶ High tech protective coatings applied
- ▶ CNC machined and drilled for exact fit
- ▶ Available exclusively from Five Star
- ▶ Mandated windshield for all NASCAR & ARCA top divisions

VISIT OUR WEBSITE FOR BODY MOUNTING GUIDELINES, TEMPLATES AND MORE!
*PRICES & PART NUMBERS SUBJECT TO CHANGE WITHOUT NOTICE.



RYAN GUTKNECHT



S2 SPORTSMAN BODIES



This body features molded plastic quarter panels for the ultimate durability. They are available in Sportsman and NASCAR Toyota Series configurations and are flange-fit for ease of installation! This body is WIND TUNNEL TESTED for superior AERO balance!

This is the EASIEST SPORTSMAN BODY TO INSTALL! The 2-piece roof configuration offers many benefits over other styles of bodies. It features mounting flanges with built-in locating tabs to speed up mounting. The greenhouse will fit all templates without hassle if mounted to proper height dimensions.

The rear greenhouse section is a unique configuration that includes integrated side window panels and a deck lid filler panel. Rear window installation is quick and hassle free!

This body features High-Impact Molded Plastic Quarter Panels for superior durability. These quarter panels have a longer life than fiberglass with equal aerodynamic performance!

Mount your own body using our Roof Locating Fixture for ease of installation in your own shop!



CHASSIS	ROOF HEIGHT	TREAD WIDTH	WHEELBASE
Common Metric Style Street Stock/Sportsman	51"	62" with 8" tires	up to 108"

Go to our downloads page at FIVESTARBODIES.com for complete body installation guidelines.

CHECK OUT WHY TOP TEAMS CHOOSE FIVE STAR!
www.FIVESTARBODIES.com/BETTERBODIES

BODY PACKAGES & OPTIONS

BODY PACKAGES

		PN	-B	-W
1	RE-SKIN PACKAGE Includes Aluminum Doors; High-Impact Molded Plastic Upper & Lower Nose, Bumper Cover, Fenders, Quarter Panels, Rocker Panels & Wear Strips	664-100-x		\$995
2	COMPLETE BODY PACKAGE Includes Aluminum Doors & Deck Lid Hold-down; High-Impact Molded Plastic Upper & Lower Nose, Bumper Cover, Fenders, Quarter Panels, Rocker Panels & Wear Strips; Standard Composite Hood, Front & Rear Greenhouses; 5" x 60" x 3/16" 70° Unpainted Spoiler; Mar-Resistant Coated Windshield & Quarter Windows; Uncoated Rear Window	664-142-x		\$2,441

MUST SPECIFY THESE ITEMS WHEN ORDERING: Body Color (White -W; Black -B), Spoiler Size & Angle, Rocker Style

BODY PACKAGE OPTIONS & UPGRADES +/- FROM PKG \$

	PKG	RACER
Rocker Panels, aluminum	1,2	+\$12
Spoiler, 6½" x 60" x 1/4"; 55°, 70° or 90°	2	\$0
Spoiler, black powder-coated brackets	2	+\$7
Window, rear, mar-resistant coated	2	+\$114
Windows without black-out (uncoated quarter windows)	2	-\$84
Wing (instead of spoiler)	2	+\$54

NOTE: All windows are pre-cut-to-fit, beveled & drilled with permanent black-out border unless specified otherwise.

HIGH-IMPACT MOLDED PLASTIC FENDERS & QUARTER PANELS

- ▶ Superior flexibility and ability to maintain structural integrity
- ▶ Durability without added weight
- ▶ Can be painted. For best results use with Five Star Plastic Primer (PN 842)
- ▶ Available in black or white **-B** **-W**



FENDER
663-23-W



QUARTER PANEL
664-27-W

DELUXE BODY MOUNTING KIT

ALL NEW

SAVE 10%

BY PURCHASING A COMPLETE KIT
vs. individual components!

EVERYTHING YOU NEED TO MOUNT YOUR NEW BODY!!

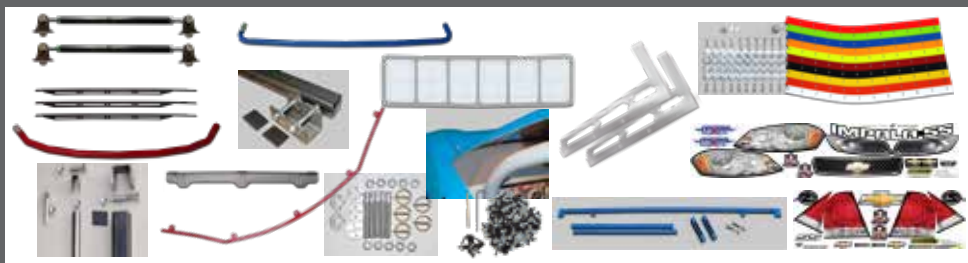

- ☑ Body/Window & Nose Braces
- ☑ Universal Bracing Kits
- ☑ Front & Rear Bumpers
- ☑ Bumper Mounting Kits
- ☑ Right Side Door Support
- ☑ Nose & Tail ID Graphics
- ☑ Wear Strips & Attachment Kits
- ☑ Hood Pin Brackets & Pins
- ☑ Rear Deck Mounting Kit
- ☑ Nose Screen
- ☑ Vent Window
- ☑ Window Installation Kit

PN# 800-2D \$770
more info pg 103

VISIT OUR WEBSITE FOR BODY MOUNTING GUIDELINES, TEMPLATES AND MORE!

NEW LATE MODEL

ABC

LATE MODEL STOCK

NASCAR PRO SERIES

ARCA RACING SERIES

S2

PAVEMENT MODIFIED

SHORT TRACK TRUCK

STRAIGHT UP METAL

STREET STOCK

MD3 DIRT LATE MODEL

MD3 DIRT MODIFIED

DIRT GRAND NATIONAL

DRAG RACING

OFF ROAD

ROAD RACING

RACING WINDOWS

BODY ADD-ONS

S2 SPORTSMAN BODY PACKAGES & OPTIONS



REPLACEMENT PANELS FOR S2 SPORTSMAN BODIES

REPLACEMENT PANELS		-B	-W	RACER				
Bumper Cover, rear, high-impact molded plastic		460-450-BorW		\$113				
Cowl Air Inlet Insert (replacement part)		661-5100A-BorW		\$44				
Deck Lid, aluminum		661-310A-BorW		\$49				
Door, aluminum, left or right		664-21A-BorWLorR		\$79				
Fender, plastic, left or right		664-23-BorWLorR		\$114				
Greenhouse Section, Front, composite		664-5112-BorW		\$233				
Greenhouse Section, Rear, composite		664-5102-BorW		\$265				
Hood, composite, flat		664-3301-BorW		\$167				
Nose, complete, 4-piece, plastic		664-410-BorW		\$176				
Nose, lower, 2-piece, plastic		664-411-BorW		\$98				
Nose, upper, 2-piece, plastic		664-412-BorW		\$78				
Nose Screen, aluminum, 1/4" mesh, unpainted		664-4112		\$47				
Nose Screen, aluminum, 3/16" mesh, unpainted		664-4111		\$47				
Nose Screen, aluminum, 1/4" mesh, black		664-4112-B		\$52				
Nose Screen, aluminum, 3/16" mesh, black		664-4111-B		\$52				
Quarter Panel, left or right		664-27-BorWLorR		\$111				
Rocker Panel, aluminum, fits either side		000-5501A-BorW		\$42				
Rocker Panel, plastic, fits either side		000-5501P-BorW		\$30				
Wing, universal fit, adjustable		664-6800		\$159				
WINDOWS		PART #		RACER				
Quarter, mar-resistant coated		724-6505LorR		\$54				
Quarter, uncoated		724-6502LorR		\$35				
Rear, mar-resistant coated, black-out border		664-6115-2B		\$305				
Rear, uncoated		664-6111-2		\$169				
Rear, uncoated, black-out border		664-6111-2B		\$191				
Windshield, pre-cut to fit		664-6325-2		\$312				
Windshield, pre-cut to fit, black-out border		664-6325-2B		\$340				
SPOILERS: 60" WIDE		5" (90°)	5" (70°)	5" (55°)	6½" (90°)	6½" (70°)	6½" (55°)	RACER
Complete, aluminum	661-6749	661-6747	661-6745	661-6739	661-6737	661-6735		\$105
Complete, aluminum, black	661-6749-B	661-6747-B	661-6745-B	661-6739-B	661-6737-B	661-6735-B		\$112
Brackets, aluminum	661-6739-1	661-6737-1	661-6735-1	661-6739-1	661-6737-1	661-6735-1		\$75
Brackets, aluminum, black	661-6739-1B	661-6737-1B	661-6735-1B	661-6739-1B	661-6737-1B	661-6735-1B		\$82
Blades, polycarbonate	661-6749-2	661-6747-2	661-6745-2	661-6739-2	661-6737-2	661-6735-2		\$30
TEMPLATES		PART #		RACER				
Complete Set, wood		664-82		\$117				

Complete Template set includes: Fenders; Nose Centerline; Body Centerline; Rear Roof side-to-side



ENHANCE YOUR BODY WITH THESE GREAT BODY ADD-ONS & ACCESSORIES

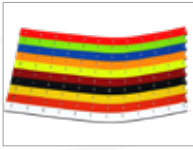

□ **WEAR STRIPS
ATTACH KITS**
..... pg 117

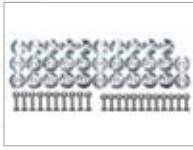

□ **SPOILER
MOUNTING KITS**
..... pg 105



□ **REAR DECK
MOUNTING KIT**
..... pg 106



□ **NOSE BRACES
TELESCOPING BRACES**
..... pg 109-110

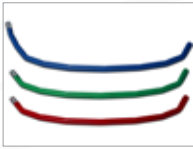

□ **BUMPERS
MOUNTING KITS**
..... pg 120



□ **DOOR VENT
WINDOWS**
..... pg 115



□ **HOOD PIN BRACKETS & KITS**
..... pg 118



□ **WINDOW
BRACES**
..... pg 111

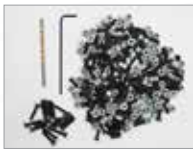

□ **WINDOW
INSTALL KITS**
..... pg 105



□ **HOOD PROPS
HOOD HINGES**
..... pg 119



□ **BODY
MOUNTING TABS**
..... pg 107



□ **BRAKE DUCTS
HOSES**
..... pg 115



□ **BACK-UP
PLATE KITS**
..... pg 111



□ **PLASTIC
PRIMER**
..... pg 122



□ **DOOR
SUPPORT**
..... pg 107



□ **RACING
MIRRORS**
..... pg 114



□ **POLYCARBONATE
RUB RAILS**
..... pg 114



□ **BODY
BRACING**
..... pg 108



□ **QUARTER PANEL
BODY BRACES**
..... pg 109



□ **GRAPHIC ID KITS**
..... pg 96



□ **SC1 DETAILER
SPEED WAX**
..... pg 123



□ **SPEED
SHIELD**
..... pg 123

FIVE STAR FEATURED PRODUCTS

HOT TIP

PROFESSIONAL BODY INSTALLERS USE THESE PRODUCTS...YOU SHOULD TOO!

#1



DETAILS » PG 116

RADIATOR AIR DUCTS

LIGHT WEIGHT & BUILT TO LAST!
Available in your choice of molded plastic or flexible!

#2



DETAILS » PG 104

RIVETS & WASHERS

EXCLUSIVE FIVE STAR BRAND

Rivets are on the best on the market!

#3



DETAILS » PG 106

ROOF LOCATING FIXTURE

THE FASTEST, EASIEST WAY
to mount a body on your own!

#4



DETAILS » PG 122

WINDOW CLEANER

MAXIMIZE OPTICAL CLARITY
in the most extreme conditions!



FIND ALL BODY ADD-ONS & ACCESSORIES // PGS 95-123

NEW LATE MODEL
ABC
LATE MODEL STOCK
NASCAR PRO SERIES
ARCA RACING SERIES
S2
PAVEMENT MODIFIED
SHORT TRACK TRUCK
STRAIGHT UP METAL
STREET STOCK
MD3 DIRT LATE MODEL
MD3 DIRT MODIFIED
DIRT GRAND NATIONAL
DRAG RACING
OFF ROAD
ROAD RACING
RACING WINDOWS
BODY ADD-ONS
S2 SPORTSMAN BODY ADD-ONS & ACCESSORIES
35



DONNIE HAMRAC



PAVEMENT MODIFIED BODIES

A body designed to fully maximize aerodynamics from front to rear! These bodies are light weight and economical with an Aerodynamically superior Roof, Nose and Hood DESIGNED FOR MAXIMUM FRONT & REAR DOWNFORCE BALANCE!

The Pavement Modified "Muscle Car" fashioned roof has built in Vortex Generators to enhance airflow. The hood design "tunnels" air effectively, preventing it from spilling off the sides.

Mount our high-impact molded plastic rear wheel flares to enhance aerodynamics and to add rigidity to the side of the body and protect your tires from being cut!

This universal design fits most short track Modified chassis legal in all major Modified racing series.

FRONT & REAR OVERHANGS	ROOF HEIGHT	FRONT DOOR HEIGHT	REAR QTR PANEL HEIGHT	OUTSIDE TO OUTSIDE OF BODY
Front: 42" max Rear: 48"	44"	30" min	36" max	66" max

Go to our downloads page at FIVESTARBODIES.com for complete body installation guidelines.



CHECK OUT WHY TOP TEAMS CHOOSE FIVE STAR!
www.FIVESTARBODIES.com/BETTERBODIES

BODY PACKAGES & OPTIONS

BODY PACKAGES

*Yellow composite body panels may be special order parts, contact Five Star for availability.

PN -B -W -CB -R -Y

1	PACKAGE A Includes Aluminum Doors, Center Hood, Nose Filler Panel, Quarter Panels & Rear Filler Panel; High-Impact Molded Plastic Nose; Composite Hood Sides, Roof & Sail Panels	CAMARO 022-112-x MUSTANG 025-112-x	\$981	\$1,061
	2	COMPLETE BODY PACKAGE Includes Aluminum Doors, Center Hood, Nose Filler Panel, Quarter Panels & Rear Filler Panel; High-Impact Molded Plastic Nose, Rocker Panels & Rear Wheel Flares; Composite Hood Sides, Hood Scoop, Roof & Sail Panels; 1/8" Thick Polycarbonate Spoiler; Mar-resistant Coated Windshield, Quarter Windows, and Flat Rear Window (requires trimming)	CAMARO 022-132-x MUSTANG 025-132-x	\$1,528

BODY PACKAGE OPTIONS & UPGRADES +/- FROM PKG \$

	PKG	-B -W	-CB -R -Y
Hood, center, composite	1,2	+\$52	+\$52
Rocker Panels, none (minus from complete package)	2	-\$96	-\$96
Spoiler, aluminum	2	\$0	\$0
Wheel Flares, none (minus from complete package)	2	-\$64	-\$64
Window, rear, molded, oversize (requires trimming), no black-out	2	+\$48	+\$48
Windshield, molded	2,3	+\$55	+\$55

NOTE: All windows are pre-cut-to-fit, beveled & drilled with permanent black-out border unless specified otherwise.

 **FIND THE COMPLETE LIST OF PANELS ON NEXT PAGE!**

3-PIECE MOLDED PLASTIC NOSE

AERODYNAMIC >> LIGHT WEIGHT >> DURABLE!



SHOWN WITH ALUMINUM FILLER PANEL (SOLD SEPARATELY)

THIS THOUGHTFULLY-ENGINEERED NOSE IS A UNIVERSAL FIT FOR MODIFIED APPLICATIONS

- > High-impact molded plastic construction
- > Adjustable front overhang up to 42"
- > Fits frame stub width up to 42"
- > Mounts between external front bumper and frame stub
- > Trim to fit around your suspension components
- > IMCA, USMTS and USRA legal
- > Available in (6) colors!

-B -W -CB -R -Y -O

VISIT OUR WEBSITE FOR BODY MOUNTING GUIDELINES, TEMPLATES AND MORE!

NEW LATE MODEL

ABC

LATE MODEL STOCK

NASCAR PRO SERIES

ARCA RACING SERIES

S2

PAVEMENT MODIFIED

SHORT TRACK TRUCK

STRAIGHT UP METAL

STREET STOCK

MD3 DIRT LATE MODEL

MD3 DIRT MODIFIED

DIRT GRAND NATIONAL

DRAG RACING

OFF ROAD

ROAD RACING

RACING WINDOWS

BODY ADD-ONS

PAVEMENT MODIFIED BODY PACKAGES & OPTIONS



REPLACEMENT PANELS FOR PAVEMENT MODIFIED BODIES

REPLACEMENT PANELS & COMPONENTS	-B	-W	RACER	-CB	-R	-Y	RACER
Door, aluminum, left or right			020-21A-xLorR				\$69
Hood, center, aluminum			020-33AC-x				\$42
Hood, center, composite			020-330C-x				\$94
Hood, side, composite, left or right			020-330-xLorR				\$69
Hood Scoop, composite			020-3330-x				\$69
Nose, plastic			020-410-x				\$169
Nose, replacement center, plastic			020-410-xC				\$40
Nose, replacement sides, plastic			020-410-xLorR				\$65
Nose Filler Panel, aluminum			020-4101A-x				\$21
Quarter Panel, aluminum, left or right			020-27A-xLorR				\$69
Rear Filler Panel, aluminum			020-450A-x				\$25
Rear Wheel Flare, plastic, left or right			007-261-xLorR				\$42
Rocker Panel, plastic, (3 required) -FG -FO -FR -FY -O			007-5500-x				\$33
Roof, composite			022-5102-x				\$198
Sail Panel, composite, Camaro, left or right			022-280-xLorR				\$56
Sail Panel, composite, Mustang, left or right			025-280-xLorR				\$56

WINDOWS	PART #	RACER
Quarter, mar-resistant coated, blacked-out, pair, Camaro	022-6505B	\$31
Quarter, mar-resistant coated, blacked-out, pair, Mustang	025-6505B	\$31
Rear, flat, .093", mar-resistant coated	020-6105-1	\$90
Rear, molded, .093", mar-resistant coated	020-6115-1	\$138
Windshield, flat, 1/8", mar-resistant coated	020-6303-2	\$166
Windshield, molded, 1/8", mar-resistant coated, black-out	020-6325-2B	\$221

SPOILERS	PART #	RACER
Spoiler, .080" aluminum	000-6702	\$31
Spoiler, 1/8" polycarbonate	000-6701	\$31

*Yellow composite body panels may be special order parts, contact Five Star for availability.



REPEATABLE FIT
REPLACEMENT PANELS THAT FIT EXACTLY THE SAME, EVERY TIME!

ENHANCE YOUR BODY WITH THESE GREAT BODY ADD-ONS & ACCESSORIES

FIVE STAR FEATURED COMPONENTS



□ **BODY MOUNTING TABS**
..... pg 107



□ **DOOR VENT WINDOWS**
..... pg 115



□ **WINDOW BRACES**
..... pg 111

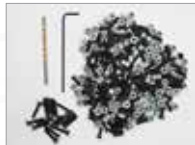

□ **WINDOW INSTALL KITS**
..... pg 105



□ **RACING MIRRORS**
..... pg 114



□ **BODY BRACING**
..... pg 108



□ **WINDOW CLEANER**
..... pg 122



□ **SC1 DETAILER**
□ **SPEED WAX**
..... pg 123



□ **PLASTIC PRIMER**
..... pg 122



□ **SPEED SHIELD**
..... pg 123

HIGH-IMPACT MOLDED PLASTIC **ROCKER PANELS & WHEEL FLARES**

THESE INTER-CONNECTING PIECES ENHANCE AERODYNAMICS, ADD RIGIDITY TO THE SIDES OF THE BODY!

► Easy to mount!

► Available in (10) colors!



WHEEL FLARES: PREVENT TIRES FROM BEING CUT BY ALUMINUM BODY PANELS!

► (2) flares per side

► Inset wheel flares fit around the full rear wheel opening



ROCKER PANELS: ADD STRUCTURAL INTEGRITY TO SIDE BODY PANELS

► **AERODYNAMICALLY DESIGNED FOR THE BEST SIDE FORCE!**

► (3) rockers complete the installation & fit either side:
(1) rocker between front and rear wheel flares, (1/2) piece behind rear wheel flare



PRICING DETAILS • PG 38



FIND ALL BODY ADD-ONS & ACCESSORIES // PGS 95-123

NEW LATE MODEL
ABC
LATE MODEL STOCK
NASCAR PRO SERIES
ARCA RACING SERIES
S2
PAVEMENT MODIFIED
SHORT TRACK TRUCK
STRAIGHT UP METAL
STREET STOCK
MD3 DIRT LATE MODEL
MD3 DIRT MODIFIED
DIRT GRAND NATIONAL
DRAG RACING
OFF ROAD
ROAD RACING
RACING WINDOWS
BODY ADD-ONS



ALL NEW

SHORT TRACK TRUCK BODY

These bodies are available in a Chevrolet Silverado or Ford F150 and are designed to fit up to 112" wheelbase chassis as specified by most tracks and associations.

MODERN STYLE & DESIGN

- » New styling based on NASCAR Truck Series Body
- » 79 1/2" width covers up to 66" tread width with 10" tires
- » Cowl Panel/Windshield base is built-in for ease of installation
- » Pre-Cut Windows standard!



BODY PACKAGES

PN -B -W

1	PACKAGE A Includes Aluminum Bed Covers, Doors, Quarter Panels, Rear Cab Filler Panel & Rocker Panels; High-Impact Molded Plastic Upper & Lower Nose, Bumper Cover & Fenders; Standard Composite Hood, Front and Rear Greenhouse	21001-10200-x	\$2,094
2	COMPLETE BODY PACKAGE Includes Aluminum Bed Covers, Doors, Quarter Panels, Rear Cab Filler Panel & Rocker Panels; High-Impact Molded Plastic Upper & Lower Nose, Bumper Cover & Fenders; Standard Composite Hood, Front and Rear Greenhouse and Cowl Airt Insert; 1-piece .080" Aluminum Spoiler up to 8"; Mar-Resistant Coated Windshield; Uncoated Rear Window	21001-10600-x	\$2,559

MUST SPECIFY THESE ITEMS WHEN ORDERING:
 Body Color: White -W; Black -B and Upper Nose Style: Chevrolet Silverado or Ford F-150

BODY PACKAGE OPTIONS & UPGRADES +/- FROM PKG \$

	PKG	RACER
Windshield, molded, oversized, coated	2	-\$28
Windshield, flat, unmolded blank	2	-\$193
Window, rear, coated	2	+\$63
Spoiler, 1/8" polycarbonate	2	\$0
Rocker Panels, pair, plastic	1,2	-\$12

ROOF HEIGHT	TREAD WIDTH	WHEELBASE
57"	66" max	112" max

Go to our downloads page at FIVESTARBODIES.com for complete body installation guidelines.

CHECK OUT WHY TOP TEAMS CHOOSE FIVE STAR!
www.FIVESTARBODIES.com/BETTERBODIES

REPLACEMENT PANELS & COMPONENTS

	CHEVROLET	-B	-W	FORD	-B	-W	RACER
Bed Cover #1, front section, aluminum	T000-351A-x			T000-351A-x			\$45
Bed Cover #2, center section, aluminum	T000-352A-x			T000-352A-x			\$77
Bed Cover #3, rear section, aluminum	T000-353A-x			T000-353A-x			\$45
Bumper, front, .065" steel, 1½" round	21001-71162			21001-71162			\$33
Bumper, rear, .065" steel, 1¾" round	T000-7503			T000-7503			\$33
Bumper Cover, rear, plastic	21001-45051-x			21001-45051-x			\$123
Door, aluminum, left or right	21001-21033-xLorR			21001-21033-xLorR			\$74
Cowl Air Insert, composite	661-5100A-BorW			661-5100A-BorW			\$44
Fender, plastic, left or right	21001-23051-xLorR			21001-23051-xLorR			\$133
Quarter Panel, aluminum, left or right	21001-27333-xLorR			21001-27333-xLorR			\$142
Graphics, Nose ID Kit	21191-44141			21341-44141			\$32
Graphics, Tail ID Kit	21191-44541			21341-44541			\$32
Hood, standard composite	21001-33011-x			21001-33011-x			\$195
Hood Pin Bracket, steel, 1/2" square	21001-34131			21001-34131			\$28
Nose, Upper, plastic	21191-41051-x			21341-41051-x			\$109
Nose, Lower, plastic	81001-41151-x			81001-41151-x			\$163
Nose Screen, Lower, aluminum, black, 1/4" mesh	81001-46433B			81001-46433B			\$52
Rear Cab Filler Panel, aluminum	T220-3200-x			T220-3200-x			\$38
Rocker Panels, aluminum	000-5501A-x			000-5501A-x			\$42
Rocker Panels, plastic	000-5501P-x			000-5501P-x			\$30
Greenhouse, Front, standard composite	21001-51311-x			21001-51311-x			\$420
Greenhouse, Rear, standard composite	21001-51511-x			21001-51511-x			\$180
WINDOWS							
Window, Rear, uncoated, .093", pre-cut, requires additional trimming	21001-61151			21001-61151			\$56
Window, Rear, mar-resistant coated, .093", oversize	21001-61153			21001-61153			\$119
Windshield, blank, mar-resistant coated, 40" x 72" x 1/8"	000-6302			000-6302			\$122
Windshield, oversize, molded, mar-resistant coated, 1/8"	21001-63202			21001-63202			\$287
Windshield, mar-resistant coated, pre-cut, black out border, 1/8"	21001-63253			21001-63253			\$315
SPOILERS							
Spoiler, 1-piece .080" aluminum, up to 8"	000-6702			000-6702			\$31
Spoiler, 1-piece 1/8" polycarbonate, up to 8"	000-6701			000-6701			\$31
TEMPLATES							
Complete Set, common, wood	21001-82091			21001-82091			\$CALL

DELUXE BODY MOUNTING KIT

**ALL
NEW**

**SAVE
10%**

**BY PURCHASING
A COMPLETE KIT**
vs. individual components!

EVERYTHING YOU NEED TO MOUNT YOUR NEW BODY!!



- Body & Window Braces
- Universal Bracing Kits
- Front & Rear Bumpers
- Bumper Mounting Kits
- Right Side Door Support
- Nose & Tail ID Graphics
- Hood Pin Brackets & Pins
- Nose Screen
- Window Installation Kit

PN# 21001-72521 \$526

more info pg 100

*graphics included-photo coming soon!

NEW LATE MODEL
ABC
LATE MODEL STOCK
NASCAR PRO SERIES
ARCA RACING SERIES
S2
PAVEMENT MODIFIED
SHORT TRACK TRUCK
STRAIGHT UP METAL
STREET STOCK
MD3 DIRT LATE MODEL
MD3 DIRT MODIFIED
DIRT GRAND NATIONAL
DRAG RACING
OFF ROAD
ROAD RACING
RACING WINDOWS
BODY ADD-ONS

SHORT TRACK TRUCK BODY PACKAGES, PANELS & ADD-ONS



REPLACEMENT PANELS FOR '02 SHORT TRACK TRUCK BODIES

REPLACEMENT PANELS & COMPONENTS	CHEVROLET -B -W	FORD -B -W	RACER
Bed Cover #1, front section, aluminum	T000-351A-x	T000-351A-x	\$45
Bed Cover #2, center section, aluminum	T000-352A-x	T000-352A-x	\$77
Bed Cover #3, rear section, aluminum	T000-353A-x	T000-353A-x	\$45
Bumper, front, .065" steel, 1¼" round	T230-7103	T250-7103	\$33
Bumper, rear, .065" steel, 1¼" round	T000-7503	T000-7503	\$33
Bumper Cover, rear, plastic	T230-450-x	T250-450-x	\$123
Dash/Windshield Base, standard composite	T230-900-x	T250-900-x	\$107
Door, aluminum, left or right	T230-21A-xLorR	T250-21A-xLorR	\$74
Fender, plastic, left or right	T230-23-xLorR	T250-23-xLorR	\$114
Graphics, Nose ID Kit	T230-410-ID	T250-410-ID	\$32
Graphics, Tail ID Kit	T230-450-ID	T250-450-ID	\$26
Hood, standard composite, flat with stock lines	T230-3301-x	T250-3301-x	\$168
Hood Pin Bracket, steel, 1/2"	T230-410-HPB	T250-410-HPB	\$28
Nose, plastic	T230-410-x	T250-410-x	\$133
Nose Screen, aluminum, 3/16" mesh, unpainted	T230-4111	T250-4111	\$47
Quarter Panel, aluminum, left or right	T230-27A-xLorR	T250-27A-xLorR	\$142
Rear Cab Filler Panel, aluminum	T220-3200-x	T250-3200-x	\$38
Roof, standard composite	T220-5102-x	T250-5102-x	\$115
Roof Post Panel, standard composite, (w/windshield & side posts, left or right)	T230-5300-xLorR	T250-5300-xLorR	\$87
WINDOWS			
Window, Rear, uncoated, .093", trimmed	T230-6101	T250-6101	\$56
Windshield, blank, mar-resistant coated, 40" x 72" x 1/8"	000-6302	000-6302	\$122
Windshield, oversize, molded, mar-resistant coated, 1/8"	T234-6325-1	T254-6325-1	\$287
SPOILERS			
Spoiler, 1-piece .080" aluminum, up to 8"	000-6702	000-6702	\$31
Spoiler, 1-piece 1/8" polycarbonate, up to 8"	000-6701	000-6701	\$31
TEMPLATES			
Complete Set, wood	T230-82	T250-82	\$58
<i>Complete Template set includes: Nose Centerline; Roof Centerline</i>			



ENHANCE YOUR BODY WITH THESE GREAT BODY ADD-ONS & ACCESSORIES

FIVE STAR FEATURED COMPONENTS



□ **BODY MOUNTING TABS**
..... pg 107



□ **RIGHT SIDE DOOR SUPPORT**
..... pg 107



□ **WINDOW BRACES**
..... pg 111

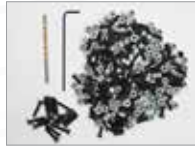

□ **WINDOW INSTALL KITS**
..... pg 105



□ **PLASTIC PRIMER**
..... pg 122



□ **BODY BRACING**
..... pg 108



□ **SPEED SHIELD**
..... pg 123



□ **SC1 DETAILER**
□ **SPEED WAX**
..... pg 123

#1

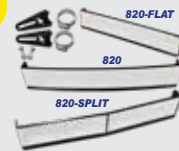

RACING MIRRORS

**OPTICALLY SUPERIOR
LOW DISTORTION
POLYCARBONATE**

Heavy duty, yet
lightweight!

DETAILS » PG 114

#2



RIVETS & WASHERS

**EXCLUSIVE
FIVE STAR
BRAND**

Rivets are on
the best on the
market!

DETAILS » PG 104

#3



WINDOW CLEANER

**MAXIMIZE
OPTICAL CLARITY**
in the most extreme
conditions!

DETAILS » PG 122

NEW LATE MODEL
ABC
LATE MODEL STOCK
NASCAR PRO SERIES
ARCA RACING SERIES
S2
PAVEMENT MODIFIED
SHORT TRACK TRUCK
STRAIGHT UP METAL
STREET STOCK
MD3 DIRT LATE MODEL
MD3 DIRT MODIFIED
DIRT GRAND NATIONAL
DRAG RACING
OFF ROAD
ROAD RACING
RACING WINDOWS
BODY ADD-ONS

SHORT TRACK TRUCK BODY PACKAGES, PANELS & ADD-ONS



FIND ALL BODY ADD-ONS & ACCESSORIES // PGS 95-123



STRAIGHT UP ALUMINUM & STEEL BODIES

These bodies are designed to fit a straight-up perimeter style chassis with a roof height of 48" and up to a 65" tread width. If wheelbase is less than 106" use standard metal doors and fenders, if wheelbase is 106-109" use extra-long aluminum doors and plastic fenders.

BODY PACKAGES		CHEVY SS		FORD FUSION	
		-B	-W	-B	-W
1	RE-SKIN PACKAGE Includes Metal Doors, Fenders, Quarter Panels, Rocker Panels; High-Impact Molded Plastic Nose & Bumper Cover	662-100 AorS	\$864	582-100 AorS	\$864
2	COMPLETE BODY PACKAGE Includes Metal Doors, Fenders, Quarter Panels, Rocker Panels & Deck Lid; High-Impact Molded Plastic Nose & Bumper Cover; Composite Deck Lid Filler, Hood, Quarter Window Panels, Roof with Integral Windshield Cowl Panel, 5" x 54" 1/2" 55° Spoiler; Mar-Resistant Coated Windshield & Quarter Windows, Uncoated Rear Window	662-142 AorS	\$2,242	582-142 AorS	\$2,242

MUST SPECIFY BODY COLOR WHEN ORDERING: White -W; Black -B

BODY PACKAGE OPTIONS & UPGRADES +/- FROM PKG \$	PKG	RACER
Bumper Cover, rear, black	1,2	\$0
Doors, aluminum, extra long	1,2	\$0
Fenders, plastic, specify black or white	1,2	+\$58
Hood, composite with 2½" scoop, white	2	\$0
Hood, composite with 2½" scoop, black	2	+\$14
Nose, black	1,2	\$0
Spoiler, all aluminum, black	2	+\$4
Spoiler, polycarbonate	2	+\$13
Spoiler, polycarbonate, black brackets	2	+\$20
Window, rear, mar-resistant coated	2	+\$114

DIMENSIONS		
Front Overhang: 46"	Rear Overhang: 47"	Front of Roof to Center Rear Axle: 57 1/2"

BODY PACKAGES & OPTIONS

UNIVERSAL REPLACEMENT PANELS & COMPONENTS

	PART #	RACER
Bumper Cover, rear, plastic, black or white	460-450-BorW	\$113
Deck Lid, aluminum, black or white	661-310A-BorW	\$49
Deck Lid, steel, white	661-310S-W	\$49
Deck Lid Filler Panel, standard composite, white	662-3200-W	\$105
Door, aluminum, standard, left or right, white	662-21A-WLorR	\$74
Door, aluminum, extra-long, left or right, black or white	662-211A-BorWLorR	\$74
Door, steel, left or right, white	662-21S-WLorR	\$74
Door, steel, extra-long left or right, white	662-211S-WLorR	\$74
Fender, aluminum, left or right, black or white	662-23A-WLorR	\$85
Fender, plastic, high clearance, left or right, black or white	662-24-BorWLorR	\$114
Fender, steel, left or right, white	662-23S-WLorR	\$85
Hood, standard composite with 2½" scoop, black	660-3303-BorW	\$167
Hood, standard composite, flat	662-3301-W	\$167
Quarter Panel, aluminum, left or right, black or white	662-27A-BorWLorR	\$114
Quarter Panel, steel, left or right, white	662-27S-WLorR	\$114
Rocker Panel, aluminum, white	000-5502A-W	\$41
Rocker Panel, steel, white	000-5502S-W	\$41
Roof, standard composite w/attached windshield posts & cowl panel, white	662-5102-W	\$212
Roof, lightweight composite w/attached windshield posts & cowl panel, white	662-5102L-W	\$423
Spoiler, 2-piece, 1/8" aluminum, 5" x 54", 55°	672-6715	\$92
Spoiler, 2-piece, 1/8" aluminum, 5" x 54", 55°, black brackets	672-6715-B	\$103
Spoiler, 4-piece, 1/4" polycarbonate blade, 5" x 54", 55°	672-6735	\$105
Spoiler, 4-piece, 1/4" polycarbonate, 5" x 54", 55°, black brackets	672-6735-B	\$112
Window, rear, mar-resistant coated, oversize, fits all	564-6115-1	\$289
Window, rear, uncoated, oversize, fits all	324-6111-1	\$144
Windshield, oversize, mar-resistant coated	564-6325-1	\$322
Windshield, pre-cut-to-fit, mar-resistant coated	564-6325-M	\$312

UNIQUE TO STYLE

	CHEVROLET	FORD	RACER
Nose, high-impact molded plastic, specify black or white	660-410-BorW	570-410-BorW	\$123
Quarter Window Panel, composite, left or right	662-280-WLorR	462-280-WLorR	\$75
Screen, nose, upper, 3/16" spacing	66A-4131	n/a	\$51
Screen, nose, upper, 3/16" spacing, black	66A-4131B	n/a	\$56
Window, quarter, molded, uncoated, pre-cut-to-fit	660-6512LorR	460-6512LorR	\$35
Window, quarter, flat, uncoated, trimmed (pair)	660-6502	460-6502	\$38
Window, rear, mar-resistant coated, pre-cut-to-fit	564-6115-M	574-6115-M	\$283

ENHANCE YOUR CAR WITH THESE GREAT

BODY ADD-ONS & ACCESSORIES



**NOSE
SCREENS**

..... pg 97



**WINDOW
CLEANER**

..... pg 122



**WINDOW
BRACES**

..... pg 111



**WINDOW
INSTALL KITS**

..... pg 105



**RACING
MIRRORS**

..... pg 114



**BODY
BRACING**

..... pg 108



FIND ALL ACCESSORY PRODUCT DETAILS // PG 95-123!

VISIT OUR WEBSITE FOR BODY MOUNTING GUIDELINES, TEMPLATES AND MORE!

NEW
LATE
MODEL

ABC

LATE
MODEL
STOCK

NASCAR
PRO
SERIES

ARCA
RACING
SERIES

S2

PAVEMENT
MODIFIED

SHORT
TRACK
TRUCK

STRAIGHT
UP METAL

STREET
STOCK

MD3
DIRT LATE
MODEL

MD3
DIRT
MODIFIED

DIRT
GRAND
NATIONAL

DRAG
RACING

OFF
ROAD

ROAD
RACING

RACING
WINDOWS

BODY
ADD-ONS

STRAIGHT-UP METAL BODY PACKAGES & REPLACEMENT PANELS



"Every piece of the body fits together perfectly!" -- ALEX CRAPSER



STREET STOCK BODIES: DIRT OR PAVEMENT

THE ECONOMICAL WAY to replace old, hard-to-find junk yard panels with the 2-piece composite roof, factory steel quarter panels and a complete line of '81-'88 Monte Carlo body panels and accessories!

We offer a complete line of '81-'88 Monte Carlo body panels that are designed to ensure stock appearance with improved mounting and fit to make installation easy!

Ditch those hard to find junk yard parts and build your entire street stock with our complete line of body accessories and any of our after-market and new factory replacement panels! All manufactured to OEM specifications.

AFTER-MARKET & NEW FACTORY REPLACEMENT PANELS

ENSURE EASY INSTALLATION AND HAVE THE STOCK APPEARANCE!



CHECK OUT WHY TOP TEAMS CHOOSE FIVE STAR!
www.FIVESTARBODIES.com/BETTERBODIES

ISO 9001:2015 CERTIFIED FIVESTARBODIES.COM | FIVESTARBODIES

BODY PACKAGES & OPTIONS

BODY PACKAGES

*Yellow composite body panels may be special order parts, contact Five Star for availability.

PN -B -W -CB -R -Y

1	RE-SKIN PACKAGE Includes Steel Doors, Factory Outer Skin Fenders and Quarter Panels; High-Impact Molded Plastic Nose (Classic or MD3 Style), Bumper Cover & MD3 Rocker Panels	601-100-x \$980
2	PACKAGE A Includes Steel Doors, Factory Outer Skin Fenders and Quarter Panels; High-Impact Molded Plastic Nose (Classic or MD3 Style), Bumper Cover, & MD3 Rocker Panels; Aluminum or Steel Deck Lid; Composite Deck Lid Filler Panel, Hood (flat or scooped), 2-piece Roof with integrated A-posts & Windshield Cowl Panel; 2-piece .080" Aluminum 70° Spoiler	601-112-x \$1,632
3	COMPLETE BODY PACKAGE Includes Steel Doors, Factory Outer Skin Fenders and Quarter Panels; High-Impact Molded Plastic Nose (Classic or MD3 Style), Bumper Cover, & MD3 Rocker Panels; Aluminum or Steel Deck Lid; Composite Deck Lid Filler Panel, Hood (flat or scooped), 2-piece Roof with integrated A-posts & Windshield Cowl Panel; 2-piece .080" Aluminum 70° Spoiler; Mar-Resistant Coated Windshield, Flat Uncoated Rear, Uncoated Quarter Windows	601-142-x \$1,973

MUST SPECIFY THESE ITEMS WHEN ORDERING: Nose Style, Color (Black -B; White -W; Blue -CB; Red -R; Yellow -Y) and Hood Shape

BODY PACKAGE OPTIONS & UPGRADES

+/- FROM PKG \$

PKG

RACER

Fenders, lower, steel	1,2,3	-\$56
Rear Roof Section, extra long, composite	2,3	+\$6
Quarter Panels, lower, steel	1,2,3	-\$220
Hood, factory outer, steel	2,3	+\$22
Interior Kit (aluminum dash, steel heater core cover & rear firewall)	2,3	+\$63
Windshield Blank, mar-resistant coated, 32" x 72" x 1/8"	3	+\$118



2-PIECE COMPOSITE ROOF WITH FACTORY STEEL QUARTER PANELS ATTACHED!

ENHANCE YOUR CAR WITH OUR VINYL NOSE & TAIL ID KITS

AN AGGRESSIVE ADHESIVE & LAMINATED PROTECTIVE COATING MAKE THESE GRAPHICS TOUGH & LONG LASTING!

PART #		RACER
600-410-ID	Nose ID Kit, Classic Nose	\$32
021-410-ID	Nose ID Kit, MD3 Nose	\$32
021-450-ID	Tail ID Kit, common	\$26



GRAPHIC ID KITS SHOWN SOLD SEPARATELY



REPLACEMENT PANELS FOR STREET STOCK BODIES

USE WITH EITHER ROOF STYLE	COLOR	PART #	RACER
Bumper, front, .065" steel, 1¾" round		600-7103	\$33
Bumper, front, steel, 1½" square		600-7101	\$33
Bumper, front, .095" steel, 1¾" round		600-7103B	\$33
Bumper, rear, steel, 1½" square		600-7501	\$33
Bumper Cover, rear, plastic	-B -W -CB -R -Y	021-450-x	\$119
Deck Lid, aluminum		601-310A-W	\$42
Deck Lid, steel		601-310S-W	\$42
Door, aluminum, left or right		601-21A-WLorR	\$68
Door, steel, left or right		601-21S-WLorR	\$68
Door, steel, IMCA-legal, left or right		601-22S-WLorR	\$68
Door, aluminum, extra-long, left or right		601-211A-WLorR	\$68
Door, steel, extra-long, left or right		601-211S-WLorR	\$68
Fender, steel, factory outer skin, IMCA-legal, left or right		601-24SLorR	\$96
Fender, Lower, aluminum, left or right		601-23A-WLorR	\$68
Fender, Lower, steel, left or right		601-23S-WLorR	\$68
Hood, composite, flat with stock lines		601-3301-W	\$135
Hood, composite, scooped		601-3303-W	\$135
Hood, steel, hood w/inner structure removed		601-3302S	\$151
Hood Pin Bracket, standard 1/2" OD		600-410-HPB	\$31
Interior Kit (aluminum dash, steel heater core cover, rear firewall)		600-904	\$63
Nose, plastic, Classic	-B -W -CB -R -Y	600-410-x	\$119
Nose, plastic, MD3	-B -W -CB -R -Y	021-410-x	\$119
Quarter Panel, steel, factory outer skin, left or right		601-28S-WLorR	\$179
Quarter Panel, Lower, steel, left or right		601-27S-WLorR	\$68
Rocker Panel, aluminum	-B -W	000-5500A-x	\$36
Rocker Panel, MD3, plastic	-B -W -CB -R -Y -FG -FO -FR -FY -O	007-5500-x	\$33
Spoiler, 2-piece, .080", aluminum, 70°		601-6702	\$48
Windshield, blank, mar-resistant coated, 32" x 72" x 1/8"		000-6301	\$99
Windshield Black-out Kit		600-6390	\$16
Windows, quarter, pair, flat, .093", uncoated, trimmed, black-out		601-6502-2B	\$53
USE WITH FACTORY STOCK ROOF ONLY		PART #	RACER
Deck Lid Filler, steel		601-320S-W	\$75
Windows, quarter, pair, flat, uncoated, trimmed		600-6502	\$32
Window, rear, molded, Aero Coupe Style, 1/8", coated, oversize		604-6125-A	\$338
Window, rear, flat, .093", uncoated, trimmed		600-6101	\$56
Windshield, flat, coated, trimmed		600-6303	\$212
USE WITH 2-PIECE COMPOSITE ROOF ONLY		PART #	RACER
Deck Lid Filler, composite		601-3200-W	\$133
Roof, front, composite, w/integrated A-posts & windshield cowl		601-5112-W	\$174
Roof, rear, composite		601-5102-W	\$128
Roof, rear, composite, extra-long		601-5104-W	\$134
Windshield, flat, 1/8", mar-resistant coated, trimmed, black-out		601-6303-2B	\$217
Window, rear, .093", flat, uncoated, pre-cut to fit, black-out		601-6101-2B	\$88
TEMPLATE		PART #	RACER
Template, wood, centerline		601-82C	\$21

*Yellow composite body panels may be special order parts, contact Five Star for availability.

ENHANCE YOUR BODY WITH THESE GREAT BODY ADD-ONS & ACCESSORIES



□ **FIVE STAR RIVETS/WASHERS**
..... pg 104



□ **HOOD PROPS**
□ **HOOD HINGES**
..... pg 119



□ **BODY MOUNTING TABS**
..... pg 107



□ **RACING MIRRORS**
..... pg 114



□ **POLYCARBONATE RUB RAILS**
..... pg 114



□ **SPEED SHIELD**
..... pg 123



□ **PLASTIC PRIMER**
..... pg 122



□ **WINDOW CLEANER**
..... pg 122



□ **SC1 DETAILER**
□ **SPEED WAX**
..... pg 123



□ **NOSE & TAIL GRAPHIC ID KITS**
..... pg 98

NOSE SCREENS

- Frame is CNC-machined from light weight quality aluminum
- Screen is high strength stainless steel (3/4" mesh is crimped, 1/4" is welded)
- Available unpainted or with durable satin black powder-coat finish

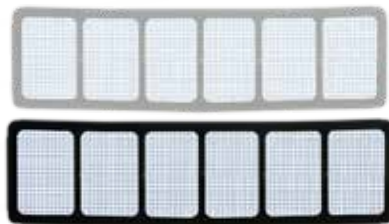

STREET STOCK		RACER
600-4131	Classic Nose, upper (3/16" mesh, unpainted)	\$47
021-4131	MD3 Nose, upper (3/16" mesh, unpainted)	\$47
021-4132	MD3 Nose, upper (1/4" mesh, unpainted)	\$47
600-4111	Classic Nose, lower (3/16" mesh, unpainted)	\$47
660-4111	MD3 Nose, lower (3/16" mesh, unpainted)	\$47
660-4112	MD3 Nose, lower (1/4" mesh, unpainted)	\$47
660-4111-B	MD3 Nose, lower (3/16" mesh, black)	\$52
660-4112-B	MD3 Nose, lower (1/4" mesh, black)	\$52

FIVE STAR FEATURED PRODUCTS

#1 MD3 PLASTIC ROCKER PANELS

LIGHT WEIGHT & BUILT TO LAST!
Aerodynamically designed for the best side force!



#2 FLEXIBLE RADIATOR DUCT

EFFICIENT FLOW COOLS RADIATOR!
Retains 100% functionality even after a hit!



DETAILS » PG 116

#3 PLASTIC WEAR STRIPS

ENHANCE DOWNFORCE
Protect the lower edge of your nose in style!



DETAILS » PG 117



FIND ALL BODY ADD-ONS & ACCESSORIES // PGS 95-123

NEW LATE MODEL

ABC

LATE MODEL STOCK

NASCAR PRO SERIES

ARCA RACING SERIES

S2

PAVEMENT MODIFIED

SHORT TRACK TRUCK

STRAIGHT UP METAL

STREET STOCK

MD3 DIRT LATE MODEL

MD3 DIRT MODIFIED

DIRT GRAND NATIONAL

DRAG RACING

OFF ROAD

ROAD RACING

RACING WINDOWS

BODY ADD-ONS

STREET STOCK BODY PANELS & ADD-ONS: PAVEMENT OR DIRT



JONATHAN DAVENPORT



DIRT LATE MODEL BODY PANELS & COMPONENTS

The MD in MD3 stands for **MAXIMUM DOWNFORCE!** Every curve and angle on our Noses, Fenders, Valances, Roofs and Hoods are designed to provide usable downforce for your car! MD3 products are proven to be the most durable, cost-effective materials for racers!

FITS MOST CURRENT BUMPER CONFIGURATIONS

AVAILABLE IN (6) COLORS: **-B** **-W** **-CB** **-OR** **-R** **-LY**

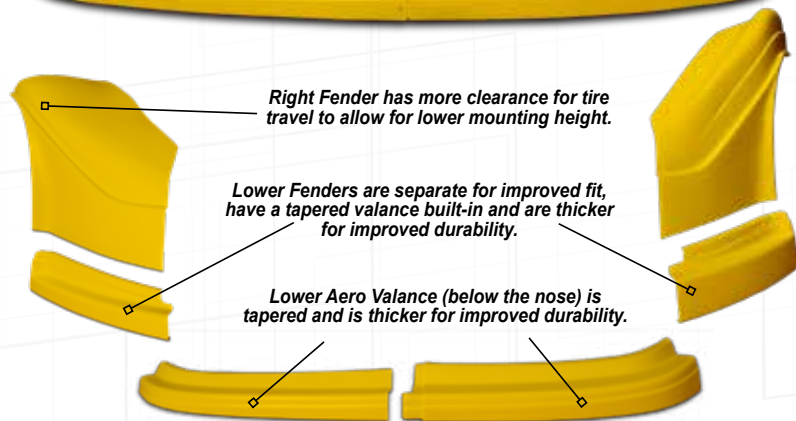

Right Fender has more clearance for tire travel to allow for lower mounting height.

Lower Fenders are separate for improved fit, have a tapered valance built-in and are thicker for improved durability.

Lower Aero Valance (below the nose) is tapered and is thicker for improved durability.







2-PIECE UPPER & LOWER FENDERS ALLOWS FOR EXACT GROUND HEIGHT ADJUSTMENT!

THE PROVEN-BEST BODY PANELS IN ALL DIRT RACING!

FIND MORE INFO ON OUR PREMIUM BODY MATERIALS // PG 4-7!

EVOLUTION 2 COMBO KITS

IMPROVED DURABILITY & FASTER INSTALLATION!

EVOLUTION 2 COMBO KITS	PN	-B	-W	-CB	-OR	-R	-Y	RACER		
CHEVROLET SS	32004-43554-x							\$399		
		Nose, Fenders, Aero Valance, Nose ID Kit								
CHEVROLET CAMARO	32004-43554-x							\$399		
		Nose, Fenders, Aero Valance, Nose ID Kit								
FORD FUSION	32004-43554-x							\$399		
		Nose, Fenders, Aero Valance, Nose ID Kit								
FORD MUSTANG	32004-43554-x							\$399		
		Nose, Fenders, Aero Valance, Nose ID Kit								
TOYOTA CAMRY	32004-43554-x							\$399		
		Nose, Fenders, Aero Valance, Nose ID Kit								

EVOLUTION 2 REPLACEMENT BODY PANELS	-B	-W	-CB	-OR	-R	-Y	RACER
Nose, complete, plastic							\$141
Nose Support, lower, plastic, 2-piece (black only)							\$33
Nose Aero Valance, lower, plastic, complete							\$53
Fender, plastic, upper, left or right							\$65
Fender, plastic, lower, left or right							\$27.50
Nose ID Kit, Chevrolet Camaro							\$32
Nose ID Kit, Chevrolet SS							\$32
Nose ID Kit, Ford Fusion							\$32
Nose ID Kit, Ford Mustang							\$32
Nose ID Kit, Toyota Camry							\$32

MD3: THE #1 CHOICE FOR TOP DIRT LATE MODEL DRIVERS!

VISIT OUR WEBSITE FOR BODY MOUNTING GUIDELINES, TEMPLATES AND MORE!

NEW LATE MODEL

ABC

LATE MODEL STOCK

NASCAR PRO SERIES

ARCA RACING SERIES

S2

PAVEMENT MODIFIED

SHORT TRACK TRUCK

STRAIGHT UP METAL

STREET STOCK

MD3 DIRT LATE MODEL

MD3 DIRT MODIFIED

DIRT GRAND NATIONAL

DRAG RACING

OFF ROAD

ROAD RACING

RACING WINDOWS

BODY ADD-ONS

MD3 DIRT LATE MODEL BODY PANELS & COMPONENTS

FIVE STAR Bodies[™] RaceCar

EVOLUTION COMBO KITS & REPLACEMENT PANELS



EVOLUTION COMBO KITS	PN	-B	-W	-CB	-OR	-R	-Y	RACER
CHEVROLET SS	32003-43554-x							\$299
	Nose, Fenders, Nose ID Kit							
CHEVROLET CAMARO	32003-43554-x							\$299
	Nose, Fenders, Nose ID Kit							
FORD FUSION	32003-43554-x							\$299
	Nose, Fenders, Nose ID Kit							
FORD MUSTANG	32003-43554-x							\$299
	Nose, Fenders, Nose ID Kit							
TOYOTA CAMRY	32003-43554-x							\$299
	Nose, Fenders, Nose ID Kit							

EVOLUTION REPLACEMENT BODY PANELS	-B	-W	-CB	-OR	-R	-Y	RACER
Nose, complete, plastic							32003-41051-x \$141
Nose Support, lower, plastic, 2-piece (black only)							32003-410-1 \$33
Nose Aero Valance, lower, plastic, complete	-FG	-FO	-FR	-FY			32003-41751-x \$75
Fender, plastic, left or right							32003-23051-xLorR \$69
Fender, plastic, FLAT right							32003-24051-xR \$69
Nose ID Kit, Chevrolet Camaro							32133-44142 \$32
Nose ID Kit, Chevrolet SS							32123-44141 \$32
Nose ID Kit, Ford Fusion							32313-44141 \$32
Nose ID Kit, Ford Mustang							32323-44141 \$32
Nose ID Kit, Toyota Camry							470-410-ID \$32

MD3 GEN 1 & GEN 2

COMBO KITS & REPLACEMENT PANELS



007-416-W SHOWN



007-416-OR SHOWN



007-416-CB SHOWN

GEN 1 & GEN 2 REPLACEMENT BODY PANELS

	-B	-W	-CB	-OR	-R	-Y	RACER
Combo Kit: Nose, Fenders (006-25), Nose ID Kit (specify Nose ID Kit)							\$299
Combo Kit: Nose, Fenders (007-25), Nose ID Kit (specify Nose ID Kit)							\$299
Fender, plastic, generation 2, left or right							\$69
Fender, plastic, generation 1 left or right							\$69
Nose, complete, plastic							\$141
Nose Aero Valance, lower, plastic, complete	-FG	-FO	-FR	-FY			\$75
Nose ID Kit, Cadillac XLR							\$32
Nose ID Kit, Chevrolet Camaro							\$32
Nose ID Kit, Chevrolet Corvette							\$32
Nose ID Kit, Dodge Challenger							\$32
Nose ID Kit, Dodge Charger							\$32
Nose ID Kit, Ferrari							\$32
Nose ID Kit, Ford Fusion: 2012							\$32
Nose ID Kit, Ford Mustang							\$32
Nose ID Kit, Pontiac GXP							\$32
Nose ID Kit, Toyota Camry							\$32
Nose Support, lower, plastic, 2-piece (black only)							\$33

CLASSIC STYLE BODY PANELS

	-B	-W	RACER
Nose, complete, plastic, universal			\$141
Nose, complete, plastic, Camaro			\$141
Fender, plastic, left or right			\$69



005-410-B SHOWN

MD3: THE #1 CHOICE FOR TOP DIRT LATE MODEL DRIVERS!

NEW LATE MODEL
ABC
LATE MODEL STOCK
NASCAR PRO SERIES
ARCA RACING SERIES
S2
PAVEMENT MODIFIED
SHORT TRACK TRUCK
STRAIGHT UP METAL
STREET STOCK
MD3 DIRT LATE MODEL
MD3 DIRT MODIFIED
DIRT GRAND NATIONAL
DRAG RACING
OFF ROAD
ROAD RACING
RACING WINDOWS
BODY ADD-ONS

MD3 DIRT LATE MODEL BODY PANELS & COMPLETE COMBO KITS

MD3 DIRT LATE MODEL COMPONENTS

THE CHOICE FOR RACE AND CHAMPIONSHIP WINNING DRIVERS!

HIGH-IMPACT MOLDED PLASTIC LOWER NOSE SUPPORT

- Install this light weight brace to connect the lower section of the nose to the bumper bar
- Fits either side; mounts between the front nose piece and front bumper

PART # (-x = color)	DESCRIPTION	RACER
32003-410-1	Black	\$33



ADVANCED LIGHTWEIGHT COMPOSITE HOOD

SHAPED FOR PEAK AERO PERFORMANCE

- Requires no support bracing and holds shape at all speeds
- Only weighs 5.7lbs!
- Slightly oversized and can be cut down to fit your application
- Tremendous shear (tear) resistance
- Available in (5) colors **-B** **-CB** **-R** **-W** **-Y**

PART # (-x = color)	DESCRIPTION	RACER
32003-33512-x	Blue, Red, Yellow	\$360
32003-33512-x	Black, White	\$340



ADVANCED LIGHTWEIGHT COMPOSITE ROOF

USED BY TOP RACERS NATIONWIDE!

- Aerodynamically designed to maximize airflow & direct air to the spoiler!
- 48" wide x 44" long, minimal bracing required
- No "ribs" for minimum aero drag
- Meets all sanctioning rules
- Available in (5) colors **-B** **-CB** **-R** **-W** **-Y**
- Includes (1) Molded Plastic Roof Cap (specify color)

PART # (-x = color)	DESCRIPTION	RACER
006-5101L-x	Roof, Dirt Late Model	\$344

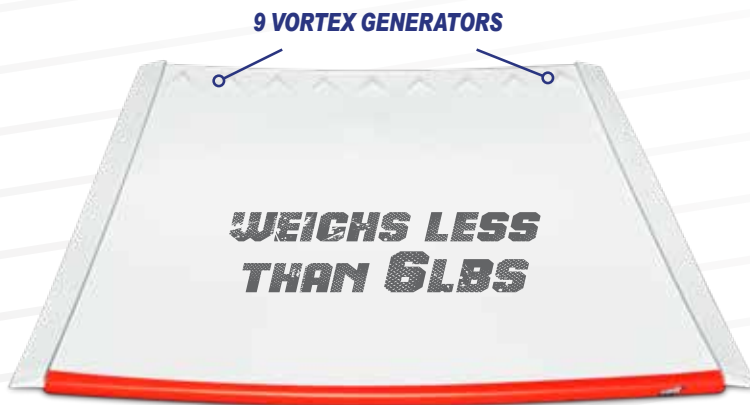

*Yellow composite body panels may be special order parts, contact Five Star for availability.

HIGH-IMPACT MOLDED PLASTIC PROTECTIVE ROOF CAPS

➤ **ONLY WEIGHS 8 OUNCES!**

- Ultra durable to withstand flying debris
- Replacements can be purchased separately
- Available in (10) colors, including a carbon fiber look (appearance of carbon fiber, at a fraction of the cost!)

-B -CB -R -W -Y -FG -FO -FR -FY -O -CF

PART # (-x = color)	DESCRIPTION	RACER
006-500-x	Roof Cap	\$25
006-500-CF	Roof Cap (carbon fiber look)	\$29

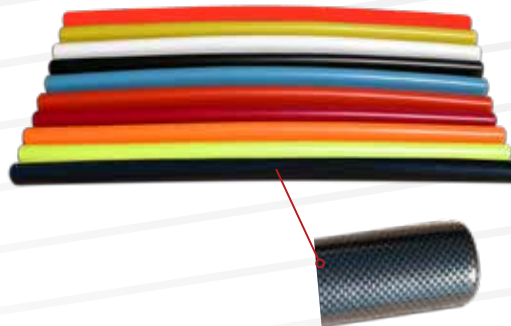

HIGH-IMPACT MOLDED PLASTIC ROCKER PANELS & WHEEL FLARES

THESE INTER-CONNECTING PIECES ENHANCE DOWNFORCE AND SIDE FORCE WHILE ALSO ADDING RIGIDITY TO THE SIDES OF THE BODY!

- Easy to mount!
- Available in (10) colors!

-B -CB -R -W -Y -FG -FO -FR -FY -O

➤ **WHEEL FLARES:**

- Prevent tires from being cut by aluminum body panels
- (3) flares needed per side to complete installation
- Inset wheel flares fit around the full rear wheel opening

ROCKER PANELS:

- Aerodynamically designed for the best side force
- Adds structural integrity to side body panels
- (3) rockers complete the installation (fit either side):
(1) rocker between front & rear wheel flares, 1/2-piece behind rear wheel flare

PART # (-x = color)	DESCRIPTION	RACER
007-2615-x	Kit: (3) Rockers, (6) Flares	\$183
007-5500-x	Rocker Panel	\$33
007-261-xLorR	Wheel Flares (3-piece set)	\$42



VISIT OUR WEBSITE FOR BODY MOUNTING GUIDELINES, TEMPLATES AND MORE!
*PRICES & PART NUMBERS SUBJECT TO CHANGE WITHOUT NOTICE.

MD3 DIRT LATE MODEL COMPONENTS

THE CHOICE FOR RACE AND CHAMPIONSHIP WINNING DRIVERS!

MOLDED PLASTIC HOOD SCOOPS

- ▶ Sleek aerodynamic designs provides maximum air filter protection!
- ▶ Available in 3" and 5" tall versions
- ▶ Available in (5) colors, including a carbon fiber look (appearance of carbon fiber, at a fraction of the cost!)

-CB **-R** **-W** **-Y** **-CF**

PART # (-x = color)	DESCRIPTION	RACER
040-4114-x	3" tall, curved	\$53
040-4116-x	5" tall, curved	\$53



Curved Scoop, 3" Tall



Curved Scoop, 5" Tall

MOLDED PLASTIC AIR DEFLECTORS

- ▶ Sleek aerodynamic designs provides maximum air filter protection!
- ▶ Available in 3" and 5" tall versions
- ▶ Available in (5) colors, including a carbon fiber look (appearance of carbon fiber, at a fraction of the cost!)

-CB **-R** **-W** **-Y** **-CF**

PART # (-x = color)	DESCRIPTION	RACER
040-4100-x	3" tall, curved	\$36
040-4101-x	5" tall, curved	\$36



Deflector, 3" Tall



Deflector, 5" Tall



*Yellow composite body panels may be special order parts, contact Five Star for availability.

MOLDED PLASTIC COCKPIT DEFLECTOR

- 3.5" tall high-impact molded plastic deflector
- Available in (5) colors, including a carbon fiber look (appearance of carbon fiber, at a fraction of the cost!)

-B **-CB** **-R** **-W** **-Y**

- 3" & 4" tall clear (-CLR) or tinted (-TNT) polycarbonate extension piece is sold separately (adds more height, with minimal visual obstruction)

PART # (-x = color)	DESCRIPTION	RACER
040-4106-x	Deflector, plastic	\$64
040-4107-x	Deflector Extension, 3" poly	\$41
040-4108-x	Deflector Extension, 4" poly	\$47



MOLDED PLASTIC OIL COOLER SCOOP

- Sleek aerodynamic designs provides maximum air filter protection!
- Can be mounted forward or backward
- 7¾" wide, 13¼" long and 3.5" high
- Available in (5) colors, including a carbon fiber look (appearance of carbon fiber, at a fraction of the cost!)

-CB **-R** **-W** **-Y** **-CF**

PART # (-x = color)	DESCRIPTION	RACER
040-4105-x	3" tall	\$32



MD3 BODY MOUNTING HARDWARE

WE HAVE ALL THE PARTS YOU NEED TO MOUNT A BODY!



➤ MD3 HIGH-IMPACT PLASTIC BODY BRACES

PG 108



➤ FIVE STAR PREMIUM RIVETS & WASHERS

PG 104

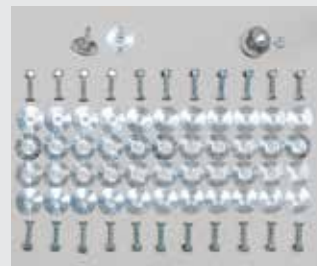

➤ MOUNT YOUR NOSE WITH OUR WEAR STRIP ATTACH KIT!

PG 117

VISIT OUR WEBSITE FOR BODY MOUNTING GUIDELINES, TEMPLATES AND MORE!
*PRICES & PART NUMBERS SUBJECT TO CHANGE WITHOUT NOTICE.



TYLER NICELY



DIRT MODIFIED BODY PANELS & COMPONENTS

The MD in MD3 stands for **MAXIMUM DOWNFORCE!** Every curve and angle on our panels & components is designed to provide usable downforce for your car!

All MD3 body panels and components are designed and engineered for **HIGH-PERFORMANCE, MAXIMUM DOWNFORCE, GREAT-STYLE** and are proven to be the most durable, cost-effective materials for racers.

Our High-Impact Molded Plastic panels have engineered high elongation which provides superior flexibility while maintaining structural integrity when hit! Advanced Lightweight Composite panels are very close to a carbon fiber blend in strength and weight, without the added costs!

Lightweight-construction, durability, and ease of installation make MD3 panels a must have for your Modified!

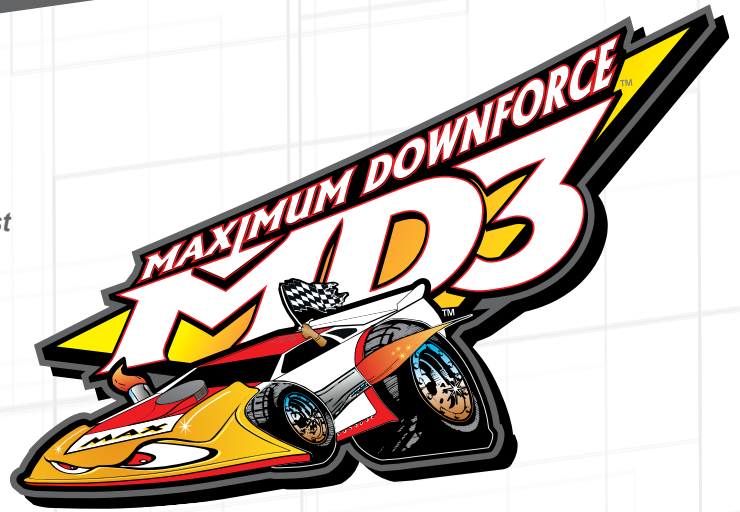

**THE PROVEN BEST BODY PANELS
IN ALL DIRT RACING!**

OFTEN IMITATED... NEVER EQUALED!

FIND MORE INFO ON OUR PREMIUM BODY MATERIALS // PG 4-7!

APPROVED FOR USE IN:



AND MOST MODIFIED RACING SANCTIONS NATIONWIDE

NOSE & AERO VALANCE OPTIONS

ENHANCE AERODYNAMICS!



MOLDED HIGH-IMPACT PLASTIC LOWER AERO VALANCE

DESIGNED TO ENHANCE AERODYNAMICS, DURABILITY AND STRUCTURE TO THE NOSE!

- ▶ Light weight, ultra durable high-impact molded plastic construction
- ▶ Universal fit for modified aluminum noses up to 45" wide (**NOT FOR USE WITH PLASTIC NOSE**)
- ▶ Adjustable front overhang up to 42"
- ▶ Can be mounted for desired ground clearance
- ▶ Available in (10) colors! **-B -CB -R -W -Y -FG -FO -FR -FY -O**
- ▶ Legal for use in all major Modified racing sanctions nationwide

PART # (-x = color)	DESCRIPTION	RACER
3022-417-x	Aero Valance	\$69



Adjustable 3-piece assembly with overlapping flanges that fit together perfectly making it easy to install!



MOLDED HIGH-IMPACT PLASTIC NOSE

3-PIECE DESIGN IS A UNIVERSAL FIT FOR MOST MODIFIED APPLICATIONS!

- ▶ Adjustable front overhang up to 42"
- ▶ Fits frame stub width up to 42"
- ▶ Mounts between external front bumper and frame stub
- ▶ Trim to fit around your suspension components
- ▶ IMCA, USMTS & USRA legal
- ▶ Available in (6) colors! **-B -W -CB -R -Y -O**



PART # (-x = color)	DESCRIPTION	RACER
020-410-x	Nose, plastic, complete	\$169

DIRT MODIFIED BODY COMPONENTS

THE PROVEN BEST BODY PANELS IN ALL DIRT RACING!

ADVANCED LIGHTWEIGHT COMPOSITE ROOF

USED BY TOP RACERS NATIONWIDE!

- Aerodynamically designed to maximize airflow directing air to spoiler!
- No "ribs" for minimum aero drag
- Built to the specified maximum allowable size currently enforced by most rule associations: 52" wide x 56" long
- Available in (5) colors **-B** **-CB** **-R** **-W** **-Y**
- Includes (1) Molded Plastic Roof Cap (specify color)

PART # (-x = color)	DESCRIPTION	RACER
3022-51112-x	Roof, Dirt Modified	\$408

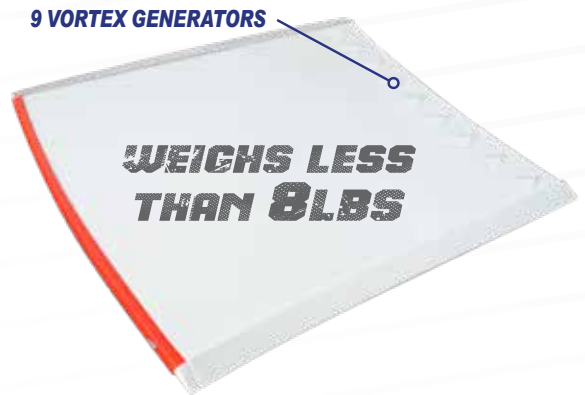

HIGH-IMPACT MOLDED PLASTIC PROTECTIVE ROOF CAPS

➤ ONLY WEIGHS 8 OUNCES!

- Ultra durable to withstand flying debris
- Replacements can be purchased separately
- Available in (10) colors, including a carbon fiber look (appearance of carbon fiber, at a fraction of the cost!)

-B **-CB** **-R** **-W** **-Y** **-FG** **-FO** **-FR** **-FY** **-O** **-CF**

PART # (-x = color)	DESCRIPTION	RACER
006-500-x	Roof Cap	\$25
006-500-CF	Roof Cap (carbon fiber look)	\$29



HIGH-IMPACT MOLDED PLASTIC ROCKER PANELS & WHEEL FLARES

THESE INTER-CONNECTING PIECES ENHANCE DOWNFORCE AND SIDE FORCE

- Easy to mount!
- Available in (10) colors!

-B **-CB** **-R** **-W** **-Y** **-FG** **-FO** **-FR** **-FY** **-O**

WHEEL FLARES:

- Prevent tires from being cut by aluminum body panels
- (2) flares for needed per side complete installation
- Inset wheel flares fit around the full rear wheel opening

ROCKER PANELS:

- Aerodynamically designed for the best side force
- Adds structural integrity to side body panels
- (3) rockers complete the installation (fit either side): (1) rocker between front and rear wheel flares, 1/2-piece behind rear wheel flare

PART # (-x = color)	DESCRIPTION	RACER
007-2615-x	Kit: (3) Rockers, (4) Flares	\$183
007-5500-x	Rocker Panel	\$33
007-261-xLorR	Wheel Flares (3-piece set)	\$42



*Yellow composite body panels may be special order parts, contact Five Star for availability.

MOLDED PLASTIC HOOD SCOOPS

- Sleek aerodynamic designs provides maximum air filter protection!
- Available in 3" and 5" tall versions
- Available in (5) colors, including a carbon fiber look (appearance of carbon fiber, at a fraction of the cost!)

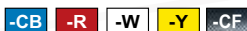

PART # (-x = color)	DESCRIPTION	RACER
040-4113-x	5" tall, flat	\$53
040-4115-x	3" tall, flat	\$53



Flat Scoop, 3" Tall



Flat Scoop, 5" Tall

MOLDED PLASTIC AIR DEFLECTORS

- Sleek aerodynamic designs provides maximum air filter protection!
- Available in 3" and 5" tall versions
- Available in (5) colors, including a carbon fiber look (appearance of carbon fiber, at a fraction of the cost!)

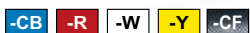

PART # (-x = color)	DESCRIPTION	RACER
040-4100-x	3" tall, curved	\$36
040-4101-x	5" tall, curved	\$36



Deflector, 3" Tall



Deflector, 5" Tall

MOLDED PLASTIC COCKPIT DEFLECTOR

- 3.5" tall high-impact molded plastic deflector
- Available in (5) colors, including a carbon fiber look (appearance of carbon fiber, at a fraction of the cost!)



- 3" & 4" tall clear (-CLR) or tinted (-TNT) polycarbonate extension piece is sold separately (adds more height, with minimal visual obstruction)

PART # (-x = color)	DESCRIPTION	RACER
040-4106-x	Deflector, plastic	\$64
040-4107-x	Deflector Extension, 3" poly	\$41
040-4108-x	Deflector Extension, 4" poly	\$47



MOLDED PLASTIC OIL COOLER SCOOP

- Sleek aerodynamic designs provides maximum air filter protection!
- Can be mounted forward or backward
- 7¾" wide, 13¼" long and 3.5" high
- Available in (5) colors, including a carbon fiber look (appearance of carbon fiber, at a fraction of the cost!)

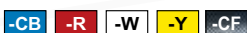

PART # (-x = color)	DESCRIPTION	RACER
040-4105-x	3" tall	\$32



VISIT OUR WEBSITE FOR BODY MOUNTING GUIDELINES, TEMPLATES AND MORE!
*PRICES & PART NUMBERS SUBJECT TO CHANGE WITHOUT NOTICE.



DIRT GRAND NATIONAL BODIES

YOU WILL NOT FIND A MORE DURABLE DIRT-STYLE BODY! Designed to fit a metric-style chassis commonly used in Dirt Sportsman divisions featuring a Composite Roof with an attached Windshield A-Post and Cowl for better hood sealing!

BODY PACKAGES

	CHEVY SS -B -W	GRAND PRIX -B -W	FORD FUSION -B -W	DODGE CHARGER -B -W	TOYOTA CAMRY -B -W
1 COMPLETE BODY PACKAGES Includes Aluminum Deck Lid, Deck Lid Filler Panel, Doors, Fenders, Quarter Panels & Rocker Panels; High-Impact Molded Plastic Nose & Bumper Cover; Standard Composite Hood, Quarter Window Panels & Roof w/Windshield Posts	701-112-x \$1,468	702-112-x \$1,468	703-112-x \$1,468	704-112-x \$1,468	705-112-x \$1,468

MUST SPECIFY BODY COLOR WHEN ORDERING: White -W; Black -B

BODY PACKAGE OPTIONS & UPGRADES +/- FROM PKG \$

	RAGER
Bumper Cover, rear, black	\$0
Fenders, plastic, black or white	+\$58
Hood, standard composite, 2½" scoop, white	\$0
Hood, standard composite, 2½" scoop, black	+\$14
Nose, black	\$0
Roof, none	-\$212

ROOF HEIGHT	TREAD WIDTH	WHEELBASE	FRONT OF ROOF TO CENTER OF REAR AXLE
51"	up to 60" with 10" tires 62" with 8" tires	up to 108"	60 1/2"

Go to our downloads page at FIVESTARBODIES.com for complete body installation guidelines.

**THE ABSOLUTE STRONGEST,
MOST DURABLE BODIES!**



FIND MORE INFO ON OUR PREMIUM BODY MATERIALS // PG 4-7!

REPLACEMENT BODY PANELS

REPLACEMENT PANELS

	PART #	RACER
Bumper, front, .065" steel, 1¼" round	700-7103	\$33
Bumper, front, .095" steel, 1¼" round	700-7103B	\$33
Bumper, rear, .065" steel, 1¼" round	570-7503	\$33
Bumper Cover, rear, plastic, black or white	460-450-BorW	\$113
Deck Lid, aluminum, white	661-310A-W	\$49
Deck Lid Filler Panel, aluminum, white	700-3200A-W	\$44
Door, aluminum, left or right, white	700-21A-WLorR	\$74
Fender, aluminum, left or right, white	662-23A-BorWLorR	\$85
Fender, plastic, high clearance, black or white, left or right	662-24-BorWLorR	\$114
Hood, standard composite, flat, black or white	362-3301-BorW	\$167
Hood, standard composite, 2½" scoop, black or white	660-3303-BorW	\$167
Quarter Panel, aluminum, left or right, white	700-27A-WLorR	\$125
Quarter Window Panel, composite, left or right, white	700-280-WLorR	\$68
Rocker Panel, aluminum, black or white	000-5500A-BorW	\$36
Roof, standard composite, white	700-5102-W	\$212

UNIQUE TO STYLE

	CHEVROLET SS	GRAND PRIX	FUSION	CHARGER	CAMRY	RACER
Hood Pin Bracket, standard 1/2" OD	700-410-HPB	700-410-HPB	703-410-HPB	700-410-HPB	700-410-HPB	\$28
Nose, plastic, black or white	660-410-BorW	360-410-BorW	570-410-BorW	470-410-BorW	720-410-BorW	\$139

SPOILERS: 60" WIDE

	5" (90°)	5" (70°)	5" (55°)	6½" (90°)	6½" (70°)	6½" (55°)	RACER
Complete, aluminum	661-6749	661-6747	661-6745	661-6739	661-6737	661-6735	\$105
Complete, black	661-6749-B	661-6747-B	661-6745-B	661-6739-B	661-6737-B	661-6735-B	\$112
Brackets, aluminum	661-6739-1	n/a	661-6735-1	661-6739-1	661-6737-1	661-6735-1	\$75
Brackets, black	661-6739-1B	661-6737-1B	661-6735-1B	661-6739-1B	661-6737-1B	661-6735-1B	\$82
Blades, polycarbonate	661-6739-2	661-6737-2	661-6735-2	661-6739-2	661-6737-2	661-6735-2	\$30

ENHANCE YOUR CAR WITH THESE GREAT BODY ADD-ONS & ACCESSORIES



NOSE SCREENS
..... pg 97



RACING MIRRORS
.....pg 114



BODY BRACING
..... pg 108



WEAR STRIPS & ATTACH KITS
.....pg 117



HOOD PIN BRACKETS & HOOD PIN KITS
.....pg 118



VINYL NOSE & TAIL GRAPHIC ID KITS
..... pg 96



FIND ALL ACCESSORY PRODUCT DETAILS // PG 95-123!

VISIT OUR WEBSITE FOR BODY MOUNTING GUIDELINES, TEMPLATES AND MORE!

NEW LATE MODEL
ABC
LATE MODEL STOCK
NASCAR PRO SERIES
ARCA RACING SERIES
S2
PAVEMENT MODIFIED
SHORT TRACK TRUCK
STRAIGHT UP METAL
STREET STOCK
M3 DIRT LATE MODEL
M3 DIRT MODIFIED
DIRT GRAND NATIONAL
DRAG RACING
OFF ROAD
ROAD RACING
RACING WINDOWS
BODY ADD-ONS

63 DIRT GRAND NAT'L BODY PACKAGES & REPLACEMENT PANELS



TANNER GRAY

CHEVROLET CAMARO SS PRO STOCK/PRO MOD BODY

These bodies are wind tunnel tested and designed for MAXIMUM PERFORMANCE! Bodies are available in your choice of (3) quality materials to meet the weight you desire. Designed to fit a 105"-115" wheelbase chassis.

APPROVED FOR USE IN:



AND MANY OTHER RACING SANCTIONS WORLD-WIDE

BODY PACKAGES	LIGHT ADVANCED LIGHTWEIGHT COMPOSITE	LIGHTER *CARBON FIBER	LIGHTEST *ULTRALIGHT CARBON FIBER
1 PRO STOCK COMPLETE BODY PACKAGE Includes Dash, Deck Lid, Doors, Front Clip (up to 105" Wheel Base), Rear Clip & Spoiler (Specify with or without scoop)	64131-10312 \$8,236	64131-10317 CALL CHEVROLET PERFORMANCE	64131-10318 CALL CHEVROLET PERFORMANCE
2 PRO STOCK COMPLETE BODY PACKAGE + WINDOWS Includes Dash, Deck Lid, Doors, Front Clip (up to 105" Wheel Base), Rear Clip & Spoiler & All Windows (Specify with or without scoop)	64131-10612 \$9,312	64131-10617 CALL CHEVROLET PERFORMANCE	64131-10618 CALL CHEVROLET PERFORMANCE
3 PRO MOD COMPLETE BODY PACKAGE Includes Dash, Deck Lid, Doors, Front Clip (106"-115" Wheel Base), Rear Clip & Spoiler (Specify with or without scoop)	65131-10312 \$8,335	65131-10317 CALL CHEVROLET PERFORMANCE	65131-10318 CALL CHEVROLET PERFORMANCE
4 PRO MOD COMPLETE BODY PACKAGE + WINDOWS Includes Dash, Deck Lid, Doors, Front Clip (106"-115" Wheel Base), Rear Clip & Spoiler & All Windows (Specify with or without scoop)	65131-10612 \$9,411	65131-10617 CALL CHEVROLET PERFORMANCE	65131-10618 CALL CHEVROLET PERFORMANCE

NOTE: Lead times may vary. Price does not include shipping or the additional \$200 crating fee for complete bodies.

***CARBON FIBER BODIES AVAILABLE THROUGH:**

CHEVROLET PERFORMANCE: BOB HERBERS
5388 Hill 23 Drive | Flint, MI 48507
(810) 239-4122 | Bob.Herbers@tgdirect.com

APPROXIMATE BODY WEIGHTS

Advanced Lightweight Composite 73 lbs
Carbon Fiber 63 lbs
Ultra Light Carbon Fiber 53 lbs

REPLACEMENT BODY PANELS

BODY PANELS	ADVANCED LIGHTWEIGHT COMPOSITE		CARBON FIBER		ULTRALIGHT CARBON FIBER	
		RACER		RACER		RACER
Dash	64131-90012	\$442	n/a	n/a	n/a	n/a
Deck Lid	64131-31012	\$190	64131-31017	*	64131-31018	*
Door, left	64131-21012L	\$870	64131-21017L	*	64131-21018L	*
Door, right	64131-21012R	\$870	64131-21017R	*	64131-21018R	*
Front Clip, Pro Stock 1-piece <small>UP TO 105" WHEELBASE, SCOOPED</small>	64132-43012	\$2,274	64132-43017	*	64132-43018	*
Front Clip, Pro Stock 1-piece <small>UP TO 105" WHEELBASE, EFI</small>	64132-43012-2	\$2,274	64132-43017-2	*	64132-43018-2	*
Front Clip, Pro Mod 1-piece <small>UP TO 115" WHEELBASE, SCOOPED</small>	65132-43012	\$2,373	65132-43017	*	65132-43018	*
Front Clip, Pro Mod 1-piece <small>UP TO 115" WHEELBASE, EFI</small>	65132-43012-2	\$2,373	65132-43017-2	*	65132-43018-2	*
Rear Clip, 1-piece	64131-51712	\$3,110	64131-51717	*	64131-51718	*
Spoiler, Spill Plates	913-6700-SP	\$169	CCS0604-SP	\$283	n/a	n/a
Spoiler, Wing	XC 962-6700L-W	\$311	XC 962-6700C-W	\$407	XC 962-6700U-W	\$597

BODY ACCESSORIES	PART #	RACER
Graphics, Nose ID Kit	60131-44142	\$32
Graphics, Tail ID Kit	60131-44542	\$26
Headlight Lens Covers (pair)	60132-68142	\$69
Template Set, Complete aluminum <small>ADD \$200 CRATING CHARGE FOR FREIGHT SHIPMENT</small>	60132-82033	\$760
Template, Nose/Body Centerline, aluminum	60132-82133	\$305

COMPLETE WINDOW PACKAGE	PART #	RACER
3/16" Windshield, 1/8" Door, Quarter & Rear Windows	64131-600-2	\$1,076

WINDOWS	3/16" THICK	RACER	1/8" THICK	RACER	.093" THICK	RACER
Door Window, left	n/a	n/a	*64131-62232L	\$160	64131-62132L	\$121
Door Window, right	n/a	n/a	*64131-62232R	\$160	64131-62132R	\$121
Quarter Window, left	n/a	n/a	*64131-65242L	\$38	64131-65142L	\$36
Quarter Window, right	n/a	n/a	*64131-65242R	\$38	64131-65142R	\$36
Rear Window	n/a	n/a	*64131-61242	\$311	64131-61142	\$240
Windshield	*64131-63332	\$369	64131-63232	\$348	n/a	n/a
Windshield, oversize	64131-63302	\$379	n/a	n/a	n/a	n/a

NOTE: All windows are pre-cut-to-fit, beveled & drilled unless specified otherwise; *Included in Complete Window Package

NEW LATE MODEL
ABC
LATE MODEL STOCK
NASCAR PRO SERIES
ARCA RACING SERIES
S2
PAVEMENT MODIFIED
SHORT TRACK TRUCK
STRAIGHT UP METAL
STREET STOCK
M3 DIRT LATE MODEL
M3 DIRT MODIFIED
DIRT GRAND NATIONAL
DRAG RACING
OFF ROAD
ROAD RACING
RACING WINDOWS
BODY ADD-ONS

ALL NEW

2019 CAMARO FRONT CLIP

DESIGNED & WIND TUNNEL TESTED TO PROVIDE THE ULTIMATE IN AERODYNAMICS!

- New updated grill and headlight areas
- Available in choice of Advanced Lightweight Composite, Carbon Fiber and Ultralight Carbon Fiber!



➤ Front clip shown with all new Nose ID Graphics Kit!



CAMARO PRO STOCK/PRO MOD BODY PACKAGES & PANELS



REPLACEMENT PANELS FOR

'17 & OLDER CAMARO PRO STOCK/PRO MOD

2017 CAMARO REPLACEMENT PANELS	ADVANCED LIGHTWEIGHT COMPOSITE	RACER	CARBON FIBER	RACER	ULTRALIGHT CARBON FIBER	RACER
	Front Clip, Pro Stock 1-piece <i>UP TO 105" WHEELBASE, SCOOPED</i>	64131-43012	\$1,880	64131-43017	*	64131-43018
Front Clip, Pro Stock 1-piece <i>UP TO 105" WHEELBASE, EFI</i>	64131-43012-2	\$1,880	64131-43017-2	*	64131-43018-2	*
Front Clip, Pro Mod 1-piece <i>UP TO 115" WHEELBASE, SCOOPED</i>	65131-43012	\$2,198	65131-43017	*	65131-43018	*
Front Clip, Pro Mod 1-piece <i>UP TO 115" WHEELBASE, EFI</i>	65131-43012-2	\$2,198	65131-43017-2	*	65131-43018-2	*

*CARBON FIBER PANELS AVAILABLE THROUGH CHEVROLET PERFORMANCE: BOB HERBERS (810) 239-4122 | BOB.HERBERS@TGIDIRECT.COM

2017 CAMARO BODY ACCESSORIES	PART #	RACER
Graphics, Nose ID Kit	60131-44141	\$32
Graphics, Tail ID Kit (Pro Mod Only)	60131-44541	\$26
Headlight Lens Covers (pair)	60131-68142	\$56
Template set, aluminum <i>ADD \$200 CRATING CHARGE FOR FREIGHT SHIPMENT</i>	60131-82033	\$760

2016 CAMARO REPLACEMENT PANELS	ADVANCED LIGHTWEIGHT COMPOSITE	RACER	CARBON FIBER	RACER	ULTRALIGHT CARBON FIBER	RACER
	Dash	960-900L	\$400	n/a	n/a	n/a
Deck Lid	961-310L	\$190	961-310C	\$310	961-310U	\$450
Door, left	961-210LL	\$870	961-210CL	\$1,040	961-210UL	\$1,280
Door, right	961-210LR	\$870	961-210CR	\$1,040	961-210UR	\$1,280
Front Clip, Pro Stock, 1-piece <i>UP TO 106" WHEELBASE</i>	962-410L	\$1,880	962-410C	\$2,770	962-410U	\$3,340
Front Clip, Pro Mod, 1-piece <i>106-115" WHEELBASE</i>	962-411L	\$1,980	962-411C	\$2,980	962-411U	\$3,640
Hood Filler Panel	n/a	n/a	n/a	n/a	64130-35818	\$510
Rear Clip, 1-piece	961-5100L	\$3,110	961-5100C	\$4,010	961-5100U	\$4,820
Spoiler, Spill Plates	913-6700-SP	\$169	CCS0604-SP	\$283	n/a	n/a
Spoiler, Wing	XC 962-6700L-W	\$311	XC 962-6700C-W	\$407	XC 962-6700U-W	\$597

2016 CAMARO BODY ACCESSORIES	PART #	RACER
Door Handle Kit, pair (both sides)	961-210DH	\$144
Graphics, Nose ID Kit	962-410-ID	\$32
Headlight/Taillight Kit, factory	962-400	\$780
Splitter, aluminum <i>USED ON THE FRONT CLIP IF SPECIFIED BY THE SANCTIONING BODY</i>	961-4200	\$40
Template set, aluminum <i>ADD \$200 CRATING CHARGE FOR FREIGHT SHIPMENT</i>	961-83	\$635

2016 CAMARO COMPLETE WINDOW PACKAGE	PART #	RACER
3/16" Windshield, 1/8" Door, Quarter & Rear Windows	961-600-2	\$1,220

2016 CAMARO WINDOWS	3/16" THICK	RACER	1/8" THICK	RACER	.093" THICK	RACER
Door Window, left	n/a	n/a	*960-6225-2L	\$160	960-6215-2L	\$132
Door Window, right	n/a	n/a	*960-6225-2R	\$160	960-6215-2R	\$132
Quarter Window, left	n/a	n/a	*960-6525-2L	\$110	960-6515-2L	\$87
Quarter Window, right	n/a	n/a	*960-6525-2R	\$110	960-6515-2R	\$87
Rear Window	n/a	n/a	*960-6125-2	\$311	960-6115-2	\$240
Windshield	*961-6335-2	\$369	n/a	n/a	n/a	n/a
Windshield, oversize	961-6335-1	\$379	n/a	n/a	n/a	n/a

NOTE: All windows are pre-cut-to-fit, beveled & drilled unless specified otherwise; *Included in Complete Window Package

CARBON FIBER FLAT SHEETS

2'X4' & 4'X8' SHEETS READY TO CUT & FIT!

PART #	THICKNESS	RACER
090-04430	.040" 2'x4' (3) carbon fiber/carbon fiber/carbon fiber	\$176
090-00220	.028" 4'x8' (2) carbon fiber/carbon fiber	\$475
090-00430	.040" 4'x8' (3) carbon fiber/carbon fiber/carbon fiber	\$650

CARBON FIBER COSMETIC BLENDS

A low cost alternative to 100% Carbon Fiber!

PART #	THICKNESS	RACER
090-04412	.040" 2'x4' (3) carbon fiber/e-glass/cosmetic carbon fiber	\$107
090-00412	.040" 4'x8' (3) carbon fiber/e-glass/cosmetic carbon fiber	\$395
090-00612	.062" 4'x8' (3) carbon fiber/e-glass/cosmetic carbon fiber	\$450
090-00421	.040" 4'x8' (3) carbon fiber/e-glass/carbon fiber	\$520



- NEW LATE MODEL
- ABC
- LATE MODEL STOCK
- NASCAR PRO SERIES
- ARCA RACING SERIES
- S2
- PAVEMENT MODIFIED
- SHORT TRACK TRUCK
- STRAIGHT UP METAL
- STREET STOCK
- MD3 DIRT LATE MODEL
- MD3 DIRT MODIFIED
- DIRT GRAND NATIONAL
- DRAG RACING
- OFF ROAD
- ROAD RACING
- RACING WINDOWS
- BODY ADD-ONS



FIND ALL BODY ADD-ONS & ACCESSORIES // PGS 95-123



MARK LUTON



FORD MUSTANG PRO STOCK/PRO MOD BODY

These bodies are wind tunnel tested and designed for MAXIMUM PERFORMANCE! Bodies are available in your choice of (3) quality materials to meet the weight you desire. Designed to fit a 105-115" wheelbase chassis.

APPROVED FOR USE IN:



AND MANY OTHER RACING SANCTIONS WORLD-WIDE

BODY PACKAGES	LIGHT	LIGHTER	LIGHTEST
	ADVANCED LIGHTWEIGHT COMPOSITE	CARBON FIBER	ULTRALIGHT CARBON FIBER
1 COMPLETE BODY PACKAGE Includes Dash, Deck Lid, Doors, Front Clip (up to 105" Wheel Base), Nose ID Kit, Rear Clip & Spoiler (Specify with or without scoop)	64321-10312 \$9,823	64321-10317 \$12,583	64321-10318 \$14,894
2 COMPLETE BODY PACKAGE + WINDOWS Includes Dash, Deck Lid, Doors, Front Clip (up to 105" Wheel Base), Nose ID Kit, Rear Clip & Spoiler & All Windows (Specify with or without scoop)	64321-10612 \$11,043	64321-10617 \$13,803	64321-10618 \$16,114
3 COMPLETE BODY PACKAGE Includes Dash, Deck Lid, Doors, Front Clip (106" - 115" Wheel Base), Nose ID Kit, Rear Clip & Spoiler (Specify with or without scoop)	65321-10312 \$9,823	65321-10317 \$12,583	65321-10318 \$14,894
4 COMPLETE BODY PACKAGE + WINDOWS Includes Dash, Deck Lid, Doors, Front Clip (106" - 115" Wheel Base), Nose ID Kit, Rear Clip & Spoiler & All Windows (Specify with or without scoop)	65321-10612 \$11,043	65321-10617 \$13,803	65321-10618 \$16,114

NOTE: Lead times may vary. Price does not include shipping or the additional \$200 crating fee for complete bodies.

APPROXIMATE BODY WEIGHTS

Advanced Lightweight Composite... 73 lbs
 Carbon Fiber 63 lbs
 Ultra Light Carbon Fiber 53 lbs

REPLACEMENT BODY PANELS

BODY PANELS	ADVANCED LIGHTWEIGHT COMPOSITE	RACER	CARBON FIBER	RACER	ULTRALIGHT CARBON FIBER	RACER
	Dash	960-900L	\$400	n/a	n/a	n/a
Deck Lid	64321-31012	\$268	64321-31017	\$365	64321-31018	\$439
Door, left	64321-21012L	\$731	64321-21017L	\$890	64321-21018L	\$1,157
Door, right	64321-21012R	\$731	64321-21017R	\$890	64321-21018L	\$1,157
Front Clip, NHRA 1-piece <small>UP TO 105" WHEELBASE, SCOOPED</small>	64321-43012	\$2,919	64321-43017	\$4,085	64321-43018	\$4,754
Front Clip, NHRA 1-piece <small>UP TO 105" WHEELBASE, EFI</small>	64321-43012-2	\$2,919	64321-43017-2	\$4,085	64321-43018-2	\$4,754
Front Clip, Pro Mod 1-piece <small>UP TO 115" WHEELBASE, SCOOPED</small>	65321-43012	\$2,919	65321-43017	\$4,085	65321-43018	\$4,754
Front Clip, Pro Mod 1-piece <small>UP TO 115" WHEELBASE, EFI</small>	65321-43012-2	\$2,919	65321-43017-2	\$4,085	65321-43018-2	\$4,754
Rear Clip, 1-piece	64321-51712	\$4,207	64321-51717	\$5,177	64321-51718	\$6,170
Spoiler, Spill Plates	913-6700-SP	\$169	CCS0604-SP	\$283	n/a	n/a
Spoiler, Wing	64321-48012	\$350	64321-48017	\$445	64321-48018	\$486

BODY ACCESSORIES	PART #	RACER
Graphics Kit, Nose ID: headlights, fog lights, sweep, upper & lower grill	60321-44141	\$48
Graphics Kit, Tail ID: taillights	64321-44541	\$26
Headlight Lens Covers (pair)	60321-68142	\$56
Taillight Covers, composite	64321-45417	\$275
Template set, aluminum <small>+CRATING CHARGE FOR FREIGHT SHIPMENT</small>	60321-82033	\$785

COMPLETE WINDOW PACKAGE	PART #	RACER
3/16" Windshield, 1/8" Door, Quarter & Rear Windows	64321-600-2	\$1,220

WINDOWS	3/16" THICK	RACER	1/8" THICK	RACER	.093" THICK	RACER
Door Window, left	n/a	n/a	*64321-62232L	\$160	64321-62132L	\$121
Door Window, right	n/a	n/a	*64321-62232R	\$160	64321-62132R	\$121
Quarter Window, left	n/a	n/a	*64321-65242L	\$110	64321-65142L	\$80
Quarter Window, right	n/a	n/a	*64321-65242R	\$110	64321-65142R	\$80
Rear Window	n/a	n/a	*64321-61242	\$311	64321-61142	\$240
Windshield	*64321-63332	\$369	64321-63232	\$340	n/a	n/a
Windshield, oversize	64321-63302	\$379	n/a	n/a	n/a	n/a

NOTE: All windows are pre-cut-to-fit, beveled & drilled unless specified otherwise; *Included in Complete Window Package

LAMINATED CARBON FIBER FLAT SHEETS

2'X4' & 4'X8' SHEETS READY TO CUT & FIT!



PART #	THICKNESS	RACER
090-04430	.040" 2'x4' (3) carbon fiber/carbon fiber/carbon fiber	\$176
090-00220	.028" 4'x8' (2) carbon fiber/carbon fiber	\$475
090-00430	.040" 4'x8' (3) carbon fiber/carbon fiber/carbon fiber	\$650

CARBON FIBER COSMETIC BLENDS

A low cost alternative to 100% Carbon Fiber!

PART #	THICKNESS	RACER
090-04412	.040" 2'x4' (3) carbon fiber/e-glass/cosmetic carbon fiber	\$107
090-00412	.040" 4'x8' (3) carbon fiber/e-glass/cosmetic carbon fiber	\$395
090-00612	.062" 4'x8' (3) carbon fiber/e-glass/cosmetic carbon fiber	\$450
090-00421	.040" 4'x8' (3) carbon fiber/e-glass/carbon fiber	\$520

VISIT OUR WEBSITE FOR BODY MOUNTING GUIDELINES, TEMPLATES AND MORE!

NEW LATE MODEL

ABC

LATE MODEL STOCK

NASCAR PRO SERIES

ARCA RACING SERIES

S2

PAVEMENT MODIFIED

SHORT TRACK TRUCK

STRAIGHT UP METAL

STREET STOCK

MD3 DIRT LATE MODEL

MD3 DIRT MODIFIED

DIRT GRAND NATIONAL

DRAG RACING

OFF ROAD

ROAD RACING

RACING WINDOWS

BODY ADD-ONS

MUSTANG PRO STOCK/PRO MOD BODY PACKAGES & PANELS



ERICA ENDERS-STEVENS



DODGE DART PRO STOCK BODY

These bodies are wind tunnel tested and designed for MAXIMUM PERFORMANCE! Bodies are available in your choice of (3) quality materials to meet the weight you desire. Designed to fit a 105" wheelbase chassis.

APPROVED FOR USE IN:



AND MANY OTHER RACING SANCTIONS WORLD-WIDE

BODY PACKAGES	LIGHT	LIGHTER	LIGHTEST
	ADVANCED LIGHTWEIGHT COMPOSITE	CARBON FIBER	ULTRALIGHT CARBON FIBER
1 COMPLETE BODY PACKAGE Includes Dash, Deck Lid, Doors, Front Clip, Rear Clip & Spoiler	P 5156290 \$8,032	P 5156282 \$10,442	P 5156282U \$12,632

NOTE: Lead times may vary. Price does not include shipping or the additional \$200 crating fee for complete bodies.

APPROXIMATE BODY WEIGHTS

- Advanced Lightweight Composite... 73 lbs
- Carbon Fiber 63 lbs
- Ultra Light Carbon Fiber 53 lbs

THE ABSOLUTE LIGHTEST BODIES!
DESIGNED FOR MAXIMUM AERO PERFORMANCE!



MOPAR and related logos, vehicle model names and trade dress are trademarks of FCA US LLC and used under license by Five Star Race Car Bodies. ©2015 FCA US LLC.

REPLACEMENT BODY PANELS

BODY PANELS	ADVANCED LIGHTWEIGHT COMPOSITE	RACER	CARBON FIBER	RACER	ULTRALIGHT CARBON FIBER	RACER
Dash, advanced lightweight composite	P 5156288	\$460	n/a	n/a	n/a	n/a
Deck Lid	P 5156295	\$210	P 5156287	\$300	P 5156287U	\$390
Door, left	P 5156293	\$890	P 5156285	\$1,060	P 5156285U	\$1,260
Door, right	P 5156294	\$890	P 5156286	\$1,060	P 5156286U	\$1,260
Front Clip, 1-piece <small>UP TO 105" WHEELBASE</small>	P 5156291	\$1,880	P 5156283	\$2,600	P 5156283U	\$3,280
Front Clip, 1-piece <small>UP TO 105" WHEELBASE, EFI</small>	P 5156291-2	\$1,880	P 5156283-2	\$2,600	P 5156283U-2	\$3,280
Front Clip, 1-piece <small>UP TO 105" WHEELBASE, WHL CUTOUTS</small>	n/a	n/a	P 5156286 H/L	\$2,600	P 5156286U H/L	\$3,280
Front Clip, 1-piece <small>UP TO 105" WHEELBASE, EFI WHL</small>	n/a	n/a	P 5156283 H/L-2	\$2,600	P 5156283U H/L2	\$3,280
Hood Filler Panel	n/a	n/a	n/a	n/a	64571-35818	\$460
Rear Body Section, 1-piece	P 5156292	\$3,260	P 5156284	\$4,270	P 5156284U	\$5,160
Spoiler, Spill Plates	P 5156297-SP	\$177	P 5156289-SP	\$259		n/a
Spoiler, Wing	P 5156297-W	\$233	P 5156289-W	\$401	P 5156289U-W	\$531

BODY ACCESSORIES

	PART #	RACER
Graphics Kit, Tail ID: tail lights	910-450-ID	\$32
Template set, aluminum <small>ADD \$200 CRATING CHARGE FOR FREIGHT SHIPMENT</small>	910-83	\$760

COMPLETE WINDOW PACKAGE

	PART #	RACER
3/16" Windshield, 1/8" Door, Quarter & Rear Windows	910-600-2	\$1,224

WINDOWS	3/16" THICK	RACER	1/8" THICK	RACER	.093" THICK	RACER
Door Window, left	n/a	n/a	*910-6225-2L	\$174	910-6215-2L	\$132
Door Window, right	n/a	n/a	*910-6225-2R	\$174	910-6215-2R	\$132
Quarter Window, left	n/a	n/a	*910-6525-2L	\$98	910-6515-2L	\$84
Quarter Window, right	n/a	n/a	*910-6525-2R	\$98	910-6515-2R	\$84
Rear Window	910-6135-2	\$339	*910-6125-2	\$340	910-6115-2	\$264
Windshield	*910-6335-2	\$404	910-6325-2	\$348	n/a	n/a

NOTE: All windows are pre-cut-to-fit, beveled & drilled unless specified otherwise; *Included in Complete Window Package

LAMINATED CARBON FIBER FLAT SHEETS

2'X4' & 4'X8' SHEETS READY TO CUT & FIT!



PART #	THICKNESS	RACER
090-04430	.040" 2'x4' (3) carbon fiber/carbon fiber/carbon fiber	\$176
090-00220	.028" 4'x8' (2) carbon fiber/carbon fiber	\$475
090-00430	.040" 4'x8' (3) carbon fiber/carbon fiber/carbon fiber	\$650

CARBON FIBER COSMETIC BLENDS

A low cost alternative to 100% Carbon Fiber!

PART #	THICKNESS	RACER
090-04412	.040" 2'x4' (3) carbon fiber/e-glass/cosmetic carbon fiber	\$107
090-00412	.040" 4'x8' (3) carbon fiber/e-glass/cosmetic carbon fiber	\$395
090-00612	.062" 4'x8' (3) carbon fiber/e-glass/cosmetic carbon fiber	\$450
090-00421	.040" 4'x8' (3) carbon fiber/e-glass/carbon fiber	\$520

NEW LATE MODEL
ABC
LATE MODEL STOCK
NASCAR PRO SERIES
RCA RACING SERIES
2
AVEMENT MODIFIED
HOCK RACK RUCK
TRAIGHT IP METAL
TREET TOCK
MD3 DIRT LATE MODEL
MD3 DIRT MODIFIED
DIRT GRAND NATIONAL
DRAG RACING
OFF ROAD
ROAD RACING
RACING WINDOWS
BODY ADD-ONS

DRAG RACING
OFF ROAD
ROAD RACING
RACING WINDOWS
BODY ADD-ONS

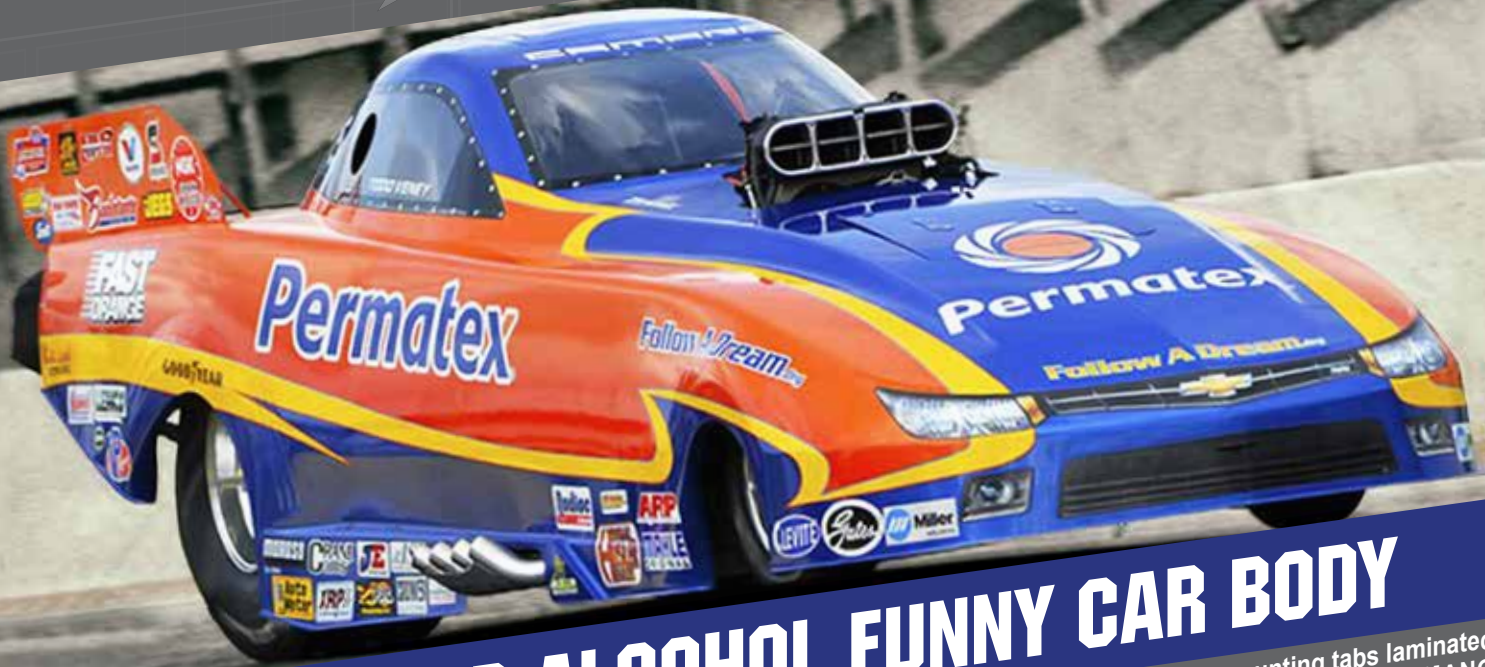

CAMARO TOP ALCOHOL FUNNY CAR BODY

This lightweight 1-piece Carbon Fiber body weighs approximately 85 lbs and has body mounting tabs laminated into structure for ease of installation. It is designed and wind tunnel tested for AERO MAXIMUM PERFORMANCE!

APPROVED
FOR USE
IN:



TOP ALCOHOL
COMPETITION

COMPLETE BODY PACKAGE	PART #	RACER
includes Tethered Burst Panel & Escape Hatch	88958780	CALL CHEVEROLET PERFORMANCE
COMPLETE WINDOW PACKAGE	PART #	RACER
includes 3/16" Windshield, 1/8" Door Windows	68131-600-2	\$622

FUNNY CAR BODY AVAILABLE THROUGH:

CHEVROLET PERFORMANCE: BOB HERBERS

5388 Hill 23 Drive, Flint, MI 48507

(810) 239-4122 • Bob.Herbers@tgidirect.com

THE ABSOLUTE LIGHTEST BODIES!

**DESIGNED FOR MAXIMUM
AERO PERFORMANCE!**

REPLACEMENT BODY PANELS

REPLACEMENT BODY PANELS	PART #	RACER
Tethered Burst Panel	88958780-B	\$435
Escape Hatch	88958780-H	\$295
Spill Plate Set	88958780-SP	\$895
Parachute Boxes, left and right	88958780-P	\$550
ACCESSORIES	PART #	RACER
Body ID Graphics Kit (Nose, Tail, Sweeps, Window Blackouts)	68131-44382	\$66
WINDOWS	PART #	RACER
Windshield, 3/16", mar-resistant coated	*68131-63352	\$402
Windshield, 1/4", mar-resistant coated	68131-63452	\$458
Window, door, pair, 1/8", mar-resistant coated	*68131-62252	\$220

NOTE: All windows are pre-cut-to-fit, beveled & drilled unless specified otherwise; *Included in Complete Window Package



LAMINATED CARBON FIBER FLAT SHEETS

2'X4' & 4'X8' SHEETS READY TO CUT & FIT!



PART #	THICKNESS	RACER
090-04430	.040" 2'x4' (3) carbon fiber/carbon fiber/carbon fiber	\$176
090-00220	.028" 4'x8' (2) carbon fiber/carbon fiber	\$475
090-00430	.040" 4'x8' (3) carbon fiber/carbon fiber/carbon fiber	\$650

CARBON FIBER COSMETIC BLENDS
A low cost alternative to 100% Carbon Fiber!

PART #	THICKNESS	RACER
090-04412	.040" 2'x4' (3) carbon fiber/e-glass/cosmetic carbon fiber	\$107
090-00412	.040" 4'x8' (3) carbon fiber/e-glass/cosmetic carbon fiber	\$395
090-00612	.062" 4'x8' (3) carbon fiber/e-glass/cosmetic carbon fiber	\$450
090-00421	.040" 4'x8' (3) carbon fiber/e-glass/carbon fiber	\$520

VISIT OUR WEBSITE FOR BODY MOUNTING GUIDELINES, TEMPLATES AND MORE!

NEW LATE MODEL
ABC
LATE MODEL STOCK
NASCAR PRO SERIES
ARCA RACING SERIES
S2
PAVEMENT MODIFIED
SHORT TRACK TRUCK
STRAIGHT UP METAL
STREET STOCK
MD3 DIRT LATE MODEL
MD3 DIRT MODIFIED
DIRT GRAND NATIONAL
DRAG RACING
OFF ROAD
ROAD RACING
RACING WINDOWS
BODY ADD-ONS

CHEVROLET CAMARO TOP ALCOHOL FUNNY CAR BODY



JERRY DOUGHERTY



PRO 2 & PRO 4 OFF ROAD TRUCK BODIES

The TOUGHEST, MOST DURABLE Off Road Truck Bodies ever made! Featuring our exclusive High-Impact Molded Plastic Fenders and Bedsides! Designed to fit most Pro 2 and Pro 4 class truck chassis.

APPROVED FOR USE IN:



AND MANY OTHER RACING SANCTIONS WORLD-WIDE

BODY PACKAGES

	SILVERADO -B -CB -W	F-150 -B -CB -W	RAPTOR -B -CB -W	RAM -B -CB -W	TUNDRA -B -CB -W	TITAN -B -CB -W
1 COMPLETE BODY PACKAGES Include Bed Sides (left & right); Doors (left & right); Fenders (left & right); Grill Panel; Hood; Roof; Roof Posts (left & right)	205-1111-x \$2,123	205-1121-x \$2,123	205-1124-x \$2,123	205-1131-x \$2,123	205-1141-x \$2,123	205-1151-x \$2,123

MUST SPECIFY BODY COLOR WHEN ORDERING: White -W; Black -B; Blue -CB

TOUGHEST, MOST DURABLE BODY MADE!

WE CHOSE THE BEST MATERIALS FOR THE PROPER DURABILITY REQUIREMENTS FOR EACH DIFFERENT BODY PANEL:

- » High-impact Molded Plastic: Fenders & Bed Sides
- » Composite: Hood, Roof, Roof Posts, Grill Panel
- » Ultraglass: Doors

EASY TO INSTALL

- » (6) body styles available, featuring manufacturer specific hoods & front Grill Panel
- » Oversized Bed Side Panels accommodate most wheelbase adjustments
- » Available in blue, black or white panels with flawless surface finish: leave body unpainted or only lightly scuff for paint prep!

REPLACEMENT BODY PANELS

REPLACEMENT BODY PANELS & COMPONENTS (-X = COLOR) -B -CB -W

	SILVERADO	F-150	RAPTOR	RAM	TUNDRA	TITAN	RACER
Bed Side, plastic	205-27-xLorR	205-27-xLorR	205-27-xLorR	205-27-xLorR	205-27-xLorR	205-27-xLorR	\$175
Door, Ultraglass	205-210-xLorR	205-210-xLorR	205-210-xLorR	205-210-xLorR	205-210-xLorR	205-210-xLorR	\$293
Fender, plastic	205-23-xLorR	205-23-xLorR	205-23-xLorR	205-23-xLorR	205-23-xLorR	205-23-xLorR	\$169
Grill Panel, composite	205-4311-x	205-4321-x	205-4324-x	205-4331-x	205-4341-x	205-4351-x	\$133
Hood, composite	205-3311-x	205-3321-x	205-3324-x	205-3331-x	205-3341-x	205-3351-x	\$204
Roof, composite	205-5102-x	205-5102-x	205-5102-x	205-5102-x	205-5102-x	205-5102-x	\$194
Roof Post, composite	205-5300-xLorR	205-5300-xLorR	205-5300-xLorR	205-5300-xLorR	205-5300-xLorR	205-5300-xLorR	\$159
Carburetor Air Box	205-5240	205-5240	205-5240	205-5240	205-5240	205-5240	\$395
Nose ID Kit, vinyl	205-4111-ID	n/a	205-4124-ID	205-4131-ID	205-4141-ID	n/a	\$39
Tail ID Kit, vinyl	205-4511-ID	n/a	205-4524-ID	205-4531-ID	205-4541-ID	n/a	\$26

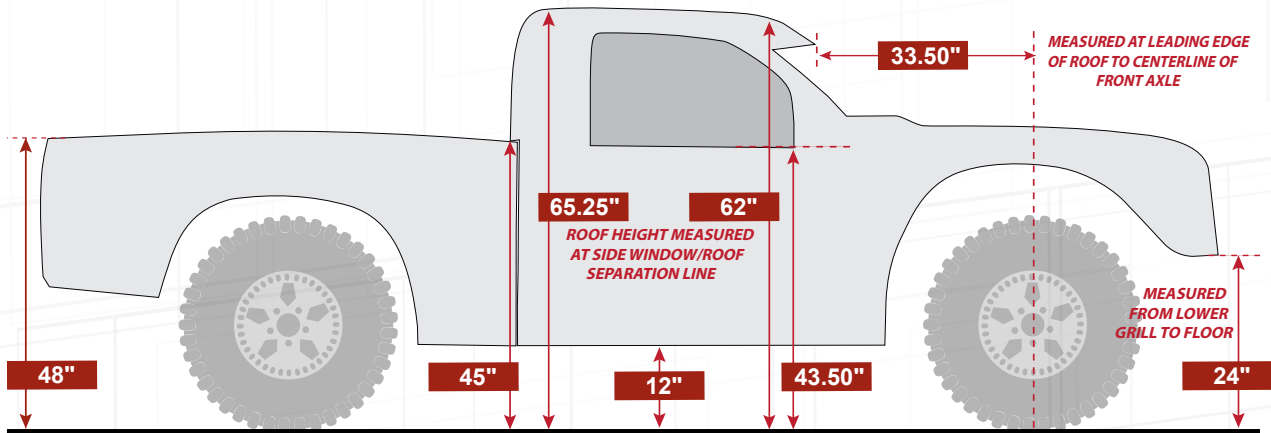

**THE ABSOLUTE STRONGEST,
MOST DURABLE BODIES!**

FIND MORE INFO ON OUR PREMIUM BODY MATERIALS // PG 4-7!



FIND ALL ACCESSORY PRODUCT DETAILS // PG 95-123!

VISIT OUR WEBSITE FOR BODY MOUNTING GUIDELINES, TEMPLATES AND MORE!

NEW LATE MODEL
ABC
LATE MODEL STOCK
NASCAR PRO SERIES
ARCA RACING SERIES
S2
PAVEMENT MODIFIED
SHORT TRACK TRUCK
STRAIGHT UP METAL
STREET STOCK
MD3 DIRT LATE MODEL
MD3 DIRT MODIFIED
DIRT GRAND NATIONAL
DRAG RACING
OFF ROAD
ROAD RACING
RACING WINDOWS
BODY ADD-ONS



ROAD RACING BODIES

These bodies were designed and built with maximum performance in mind! Made from our EXCLUSIVE ADVANCED LIGHTWEIGHT COMPOSITE & ULTRAGLASS, laminate blends which make the STRONGEST, LIGHTEST WEIGHT PANELS WITHOUT COMPROMISING RIGIDITY.

APPROVED
FOR USE
IN:

Trans Am
AMERICA'S ROAD RACING SERIES
TA2 CLASS

AERODYNAMIC > LIGHT WEIGHT > DURABLE

- » Lighter than their predecessors, yet substantially stronger and more durable
- » More resistant to regular wear and tear over the course of the season, with the end goal of reducing a team's net annual bodywork expense
- » Withstands impact under normal racing conditions and will not leave debris on the track

WILL CUT LABOR COSTS & INSTALL TIME!

- » Installation of these updated bodies is vastly improved, reducing install time and making it easier to perform any necessary repairs!

**THE ABSOLUTE STRONGEST,
LIGHTEST WEIGHT BODIES!**

PANELS MADE OF EXCLUSIVE ADVANCED LIGHTWEIGHT
COMPOSITE & ULTRAGLASS!



FIND MORE INFO ON OUR PREMIUM BODY MATERIALS // PG 4-7!

REPLACEMENT BODY PANELS

BODY PACKAGES		CAMARO	MUSTANG
1	COMPLETE PACKAGE Includes Advanced Lightweight Composite Nose, Bumper Cover, Hood, Front & Rear Greenhouse Sections; Ultraglass Deck Lid, Doors, Fenders & Quarter Panels	81131-103 CONTACT DEALER	81321-103 CONTACT DEALER
2	COMPLETE PACKAGE + WINDOWS Includes Advanced Lightweight Composite Nose, Bumper Cover, Hood, Front & Rear Greenhouse Sections; Ultraglass Deck Lid, Doors, Fenders & Quarter Panels; Coated Windshield, Quarter Windows & Rear Window	81131-106 CONTACT DEALER	81321-106 CONTACT DEALER

FOR BODY PACKAGE AND REPLACEMENT PANEL PRICING CONTACT AUTHORIZED DEALER!

UNIVERSAL REPLACEMENT PANELS	CAMARO	RACER	MUSTANG	RACER
Deck Lid, Ultraglass	81131-31013	CONTACT DEALER	81321-31013	CONTACT DEALER
Door, Ultraglass, left or right	81131-21013LorR	CONTACT DEALER	81321-21013LorR	CONTACT DEALER
Door, increased access, upper, small, Ultraglass, left	81131-21713L	CONTACT DEALER	81321-21713L	CONTACT DEALER
Door, increased access, lower, large, Ultraglass, left	81131-21813L	CONTACT DEALER	81321-21813L	CONTACT DEALER
Fender, Ultraglass, left or right	81131-23013LorR	CONTACT DEALER	81321-23013LorR	CONTACT DEALER
Fender, narrow, Ultraglass, left or right	81132-23013LorR	CONTACT DEALER	81322-23013LorR	CONTACT DEALER
Greenhouse, Front, advanced lightweight composite	81131-51312	CONTACT DEALER	81321-51312	CONTACT DEALER
Greenhouse, Rear, advanced lightweight composite	81131-51512	CONTACT DEALER	81321-51512	CONTACT DEALER
Hood, advanced lightweight composite	81131-33012	CONTACT DEALER	81321-33012	CONTACT DEALER
Nose, Upper, advanced lightweight composite	81131-41212-W	CONTACT DEALER	81321-41212-W	CONTACT DEALER
Nose, Upper, narrow, advanced lightweight composite	81132-41212	CONTACT DEALER	81322-41212	CONTACT DEALER
Nose, Upper, molded plastic	81131-41251	CONTACT DEALER	81321-41251	CONTACT DEALER
Nose, Lower, advanced lightweight composite, common	81001-41112	CONTACT DEALER	81001-41112	CONTACT DEALER
Nose, Lower, narrow, advanced lightweight composite, common	81002-41112	CONTACT DEALER	81002-41112	CONTACT DEALER
Nose, Lower, molded plastic	81001-41151-W	CONTACT DEALER	81001-41151-W	CONTACT DEALER
Quarter Panel, Ultraglass, left or right	81131-27313LorR	CONTACT DEALER	81321-27313LorR	CONTACT DEALER
Quarter Panel, narrow, Ultraglass, left or right	81131-27313LorR	CONTACT DEALER	81322-27313LorR	CONTACT DEALER
Rear Bumper Cover, advanced lightweight composite	81131-45012	CONTACT DEALER	81321-45012	CONTACT DEALER
Template, Body Centerline, wood	811311-82191	\$40	81321-82191	\$40
Template, Nose Centerline, wood	81001-82491	\$16	81001-82491	\$16
Template, Body Centerline, aluminum	81131-82133	\$125	81321-82133	\$125
Template, Nose Centerline, aluminum	81131-82433	\$60	81321-82433	\$60
WINDOWS				
Quarter, 1/8", coated, black-out, left or right	81131-65243LorR	\$48	81321-65243LorR	\$48
Rear, 1/8", coated, black-out border	81131-61243	\$370	81321-61243	\$370
Windshield, 3/16", coated, cut, bev, drilled, black-out	81131-63343	\$418	81321-63343	\$418

ROAD RACING BODIES AVAILABLE THROUGH:

MIKE COPE RACING ENTERPRISES, INC.
11692 56TH COURT NORTH
CLEARWATER, FL 33760
ph: (727) 201-8910

HOWE RACING ENTERPRISES
3195 LYLE ROAD
BEAVERTON, MI 48612
ph: (989) 435-7080

NEW LATE MODEL
ABC
LATE MODEL STOCK
NASCAR PRO SERIES
ARCA RACING SERIES
S2
PAVEMENT MODIFIED
SHORT TRACK TRUCK
STRAIGHT UP METAL
STREET STOCK
M3 DIRT LATE MODEL
M3 DIRT MODIFIED
DIRT GRAND NATIONAL
DRAG RACING
OFF ROAD
ROAD RACING
RACING WINDOWS
BODY ADD-ONS

ENHANCE YOUR BODY WITH THESE GREAT BODY ADD-ONS & ACCESSORIES

LIGHTWEIGHT FORMED STEEL FRONT & REAR BUMPERS

EXACTLY CONTOURED TO THE INSIDES OF OUR PLASTIC NOSES FOR MAXIMUM PROTECTION!

- ▶ Formed from 1.50" round steel tubing and easy to install!

PART #		RACER
81131-71162	Front, Chevrolet, .065" steel	\$30
81131-71662	Rear, Chevrolet, .065" steel	\$30
81321-71162	Front, Ford, .065" steel	\$30
81321-71662	Rear, Ford, .065" steel	\$30



LIGHTWEIGHT FRONT & REAR WINDOW BRACES

- ▶ Application-specific to fit the exact contour of your Five Star windows!
- ▶ Made of premium light weight high-strength aluminum!
- ▶ Low gloss black powder-coat finish!
- ▶ Available in a 3-piece kit

PART #		RACER
81131-76333	Front, Chevrolet, 3-piece	\$57
81131-76133	Rear, Chevrolet, 3-piece	\$57
81321-76333	Front, Ford, 3-piece	\$57
81321-76133	Rear, Chevrolet, .3-piece	\$57



Front Braces



Rear Braces

PLASTIC UNIVERSAL SPLITTER

CREATES MORE FRONT DOWNFORCE

- ▶ High-Impact Molded Plastic construction
- ▶ Easy to install!
- ▶ 2-piece splitter mounts to the return under nose to close off the bottom
- ▶ Approved for use in Trans Am Racing Series

PART #		RACER
81001-41851	Splitter, plastic	\$118



LOWER NOSE SCREEN

- ▶ Frame is CNC-machined from light weight quality aluminum
- ▶ 1/4" mesh screen is high strength stainless steel
- ▶ Durable satin black powder-coat finish

PART #		RACER
81001-46433B	black, common	\$52



LIGHTWEIGHT ALUMINUM

HOOD PIN BRACKETS

PREFORMED TO FIT THE TOP OF THE NOSE TO MEET TEMPLATES!

- 3/4" square aluminum brackets
- Includes (4) tabs for (4) hood pins

PART #		RACER
81131-34333	Chevrolet, aluminum	\$52
81321-34333	Ford, aluminum	\$52

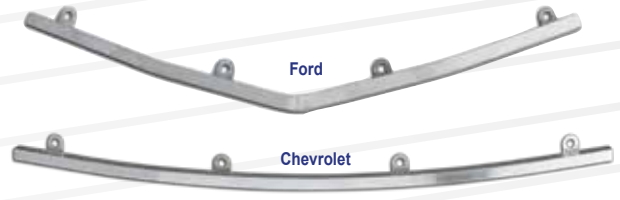

LIGHTWEIGHT ALUMINUM

HOOD PIN KITS

- Flip-over style prevents clips from falling out
- 1/2" Kit includes: (5) aluminum pins, (5) aluminum scuff plates, (5) flip-over steel clips, (10) jam nuts
- 3/8" Kit includes: (5) newly improved gun-drilled aluminum pins (half the weight of standard), (5) aluminum scuff plates, (5) flip-over steel clips, (10) jam nuts

PART #		RACER
803-A	3/8" pin kit	\$33
803	1/2" pin kit	\$33
803-PS	1/2" Scuff Plate, aluminum	\$2
803-PA3/8	3/8" Scuff Plate, aluminum	\$2



803 1/2" Hood Pin Kit



803-A 3/8" Hood Pin Kit

VINYL NOSE & TAIL GRAPHIC ID KITS

GET THE OEM LOOK WITH OUTSTANDING REALISTIC DETAILS!

- Printed on 6-year outdoor durable high-tack vinyl with aggressive adhesive
- Glossy laminated surface provides excellent sandblast and chemical protection!

PART #		RACER
81131-44141	Nose ID, Chevrolet Camaro	\$38
81131-44541	Tail ID, Chevrolet Camaro	\$26
81321-44141	Nose ID, Ford Mustang	\$38
81321-44541	Tail ID, Ford Mustang	\$26



VISIT OUR WEBSITE FOR BODY MOUNTING GUIDELINES, TEMPLATES AND MORE!
*PRICES & PART NUMBERS SUBJECT TO CHANGE WITHOUT NOTICE.



FIVE STAR
RaceCar Bodies™
CUSTOM FORMED
RACING WINDOWS

THE HIGHEST QUALITY WINDOWS AVAILABLE!

TOP 5 REASONS WHY FIVE STAR WINDOWS ARE #1 IN ALL MOTORSPORTS!

#1

EXCLUSIVE OPTICAL GRADE MATERIALS

WE USE A GRADE OF POLYCARBONATE MATERIAL DEVELOPED EXCLUSIVELY FOR (AND ONLY AVAILABLE FROM) FIVE STAR

#2

MULTIPLE HARD-COATING OPTIONS

WE OFFER MULTIPLE COATING TYPES TO BEST SUIT YOUR NEEDS. THESE COATINGS GREATLY ENHANCE DURABILITY WITH ABRASION & CHEMICAL RESISTANCE, UV PROTECTIVE & ANTI-FOGGING COATINGS!

#3

SCREEN PRINTED BLACK-OUT BORDERS

SCRATCH-RESISTANT, NON-FLAKING PERMANENT INK BORDERS GIVE YOU A CLEAN PROFESSIONAL LOOK THAT SAVES YOU HOURS OF PREP & AGGRAVATION!

#4

WORLD-CLASS CUSTOM FORMING

WE INVENTED OUR OWN FORMING PROCESS WHICH ASSURES YOU THE PERFECT OPTICS AND DROP IN FIT!

#5

CNC TRIMMED FOR EASY INSTALLATION

CNC-CUT TO SIZE WITH CONSISTENT PERFECT FIT, SMOOTH BEVELED EDGES & PRE-DRILLED HOLES FOR EASY INSTALLATION!

NEW LATE MODEL
ABC
LATE MODEL STOCK
NASCAR PRO SERIES
ARCA RACING SERIES
S2
PAVEMENT MODIFIED
SHORT TRACK TRUCK
STRAIGHT UP METAL
STREET STOCK
MD3 DIRT LATE MODEL
MD3 DIRT MODIFIED
DIRT GRAND NATIONAL
DRAG RACING
OFF ROAD
ROAD RACING
RACING WINDOWS
BODY ADD-ONS

RACING WINDOWS OPTIONS

EXPLORE OUR FULL SELECTION OF RACING WINDOW OPTIONS

WE OFFER MORE OPTIONS THAN ANYBODY ELSE TO BUILD THE PERFECT WINDOW FOR YOUR BUDGET!

FULL LIST OF OPTIONS

MATERIAL

- Monolithic Polycarbonate (Standard)
- Five Star SafeGuard Laminated Polycarbonate

THICKNESS

- 0.093" ➤ 0.118" (1/8") ➤ 3/16" (0.177") ➤ 1/4" (0.236")

COATING

- Mar-Resistant Coated
- Un-Coated (Economy)

CUT

- **OVERSIZE:** Cut 2-inches larger than the window frame; may require cutting, trimming, beveling and drilling.
- **PRE-CUT TO FIT:** Straight-cut to fit exactly into the window frame.

EDGE TREATMENT

- Edges are machine beveled and will fit exactly into the window frame.

INSTALLATION OPTIONS

- **DRILLED:** Installation holes are pre-drilled.
- **COUNTERSUNK:** Installation holes are pre-drilled and countersunk

BLACKED-OUT BORDER

- Professional appearance is printed with ultra-durable, high-quality, scratch-resistant and non-flaking permanent ink.
- Blacked-out Borders are available on custom formed windows for higher-quantity production runs only. Call Customer Service for details.

NOTE: All options are not available on all windows.



DRILLED & COUNTER SUNK



MACHINE BEVELED ALONG EDGES



.093", .118", .177", .236"

MULTIPLE THICKNESSES



BLACKED-OUT BORDER

COATED WINDOWS LAST LONGER!

YOU'RE NOT SAVING MONEY WHEN YOUR WINDOWS DON'T LAST LONG...

- Uncoated polycarbonate offers no protection against scratching, and cleaning an uncoated window can cause scratch marks that affect visibility!

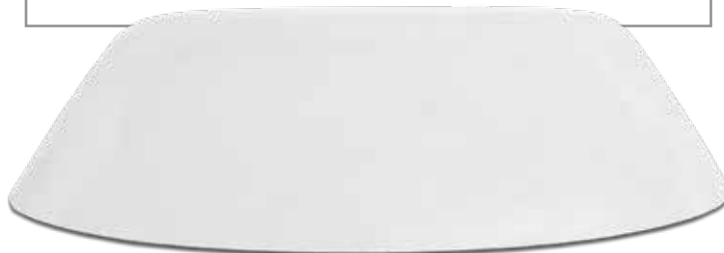

**IF WE DON'T HAVE YOUR WINDOW...
GET ONE CUSTOM MADE!**



**MEASURING FOR
YOUR CUSTOM WINDOW:**

**THESE TWO MEASUREMENTS
ARE NEEDED TO DETERMINE
WHICH SHEET TO PURCHASE:**

► **DIM A: THE HEIGHT:** Place your window on end upon a level space with the roof edge down. Measure (DIM A), from the floor to the highest point.

► **DIM B: THE WIDTH:** Measure across the widest point (DIM B) to be sure that the width does not exceed 70".

► If DIM A is less than 39" use Sheet #1

► If DIM A is 39-47" use Sheet #2

► Oversized molded sheets are typically 1½" larger than stock (you cut it to fit)

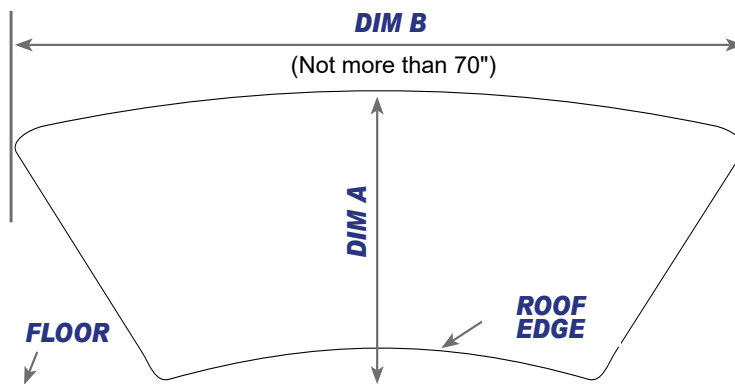

CUSTOM MOLDED WINDOW PRICING

MATERIAL	THICKNESS	SHEET #	
		DIM A (UP TO 39")	DIM A (39"- 47")
Uncoated	.093"	\$144	\$162
Mar-resistant Coated	.093"	\$258	\$295
Uncoated	.118" (1/8")	n/a	\$205
Mar-resistant Coated	.118" (1/8")	\$287	\$325
Mar-resistant Coated	.177" (3/16")	\$344	\$376
Mar-resistant Coated	.236" (1/4")	\$413	\$501

- Prices on this chart include all forming costs. **THESE ARE NOT FLAT SHEETS!**
- Contact a Five Star Customer Service Rep for complete ordering information to determine whether or not factory glass is needed for forming purposes.

POLYCARBONATE FLAT SHEETS

**TOP QUALITY POLYCARBONATE,
AT AFFORDABLE PRICES!**



PART #	THICKNESS	COATING	INFO	RACER
000-6102	.093"	40" x 72"	uncoated	\$61
000-6300	.118" (1/8")	24" x 48"	mar-resistant	\$50
000-6301	.118" (1/8")	32" x 72"	mar-resistant	\$99
000-6303	.118" (1/8")	36" x 72"	mar-resistant	\$111
000-6302	.118" (1/8")	40" x 72"	mar-resistant	\$122
000-6306	.118" (1/8")	72" x 96"	mar-resistant	\$294
000-6304	.177" (3/16")	36" x 72"	mar-resistant	\$134

- Mar-resistant flat sheets **CANNOT BE THERMOFORMED!**
- Free Shipping for orders of (10) flat polycarbonate sheets or more!
- Custom sheet sizes are available upon request. Minimum order required!

NEW LATE MODEL
ABC
LATE MODEL STOCK
NASCAR PRO SERIES
ARCA RACING SERIES
S2
PAVEMENT MODIFIED
SHORT TRACK TRUCK
STRAIGHT UP METAL
STREET STOCK
MD3 DIRT LATE MODEL
MD3 DIRT MODIFIED
DIRT GRAND NATIONAL
DRAG RACING
OFF ROAD
ROAD RACING
RACING WINDOWS
BODY ADD-ONS

RACING WINDOW OPTIONS

COMPLETE WINDOW PRODUCT LINE FOR

**FACTORY STOCK DIMENSION - ROAD RACE
UNIVERSAL SHORT TRACK - SHORT TRACK TRUCK**



**THE #1 WINDOWS USED
IN ALL MOTORSPORTS!**

WINDOWS MADE FROM OUR EXCLUSIVE OPTICAL
GRADE MATERIAL THAT NOBODY ELSE CAN OFFER!



FIND MORE INFO ON OUR PREMIUM MATERIALS // PG 7!

DESCRIPTION	PART #	THICKNESS	OPTIONS					RACER
			OVERSIZE	CUT TO FIT	BEVELED	DRILLED	COUNTERSINK	
FACTORY STOCK DIMENSION WINDOWS								
CHEVROLET CAMARO: 2010-2012								
Window, Front	164-6335-2	3/16"		✓				\$413
Window, Front	164-6345-1	1/4"		✓				\$462
Window, Front	164-6345-2	1/4"		✓				\$491
Window, Door, left or right	164-6225-2(L or R)	1/8"		✓				\$196 ea
Window, Door, left or right	164-6235-2(L or R)	3/16"		✓				\$233 ea
Window, Quarter, left or right	164-6525-2(L or R)	1/8"		✓				\$77 ea
Window, Quarter, left or right	164-6535-2(L or R)	3/16"		✓				\$88 ea
Window, Rear	164-6125-1	1/8"		✓				\$322
Window, Rear	164-6125-2	1/8"		✓				\$349
Window, Rear	164-6135-2	3/16"		✓				\$400
CHEVROLET CAMARO: 1993-2002								
Window, Front	150-6325-2	1/8"		✓				CALL
Window, Front	150-6325-STK	1/8"		✓				\$363
Window, Front	150-6335-2	3/16"		✓				\$403
Window, Front	150-6335-STK	3/16"		✓				\$389
Window, Front	150-6345-STK	1/4"		✓				\$441
Window, Rear, uncoated	150-6111	.093"		✓				\$182
Window, Rear	150-6115	.093"		✓				\$330
Window, Rear	150-6125-STK	1/8"		✓				\$363
Window, Rear	150-6135-STK	3/16"		✓				\$389
CHEVROLET CAMARO: 1982-1992								
Window, Front	524-6325	1/8"		✓				\$322
Window, Rear, uncoated	110-6111	.093"		✓				\$182
Window, Rear	110-6115	.093"		✓				\$330
Window, Rear	110-6125	1/8"		✓				\$363
Window, Rear	110-6135	3/16"		✓				\$389
CHEVROLET CAMARO: 1967-1969								
Window, Complete Package	114-600-STK	1/8"						CALL
> Window, Rear	114-6125-STK	1/8"		✓				\$184
> Windows, Door pair	114-6225-STK	1/8"		✓				CALL
> Window, Front	114-6325-STK	1/8"		✓				\$184
> Window, Quarters, pair	114-6525-STK	1/8"		✓				CALL
Window, Front	114-6335-STK	3/16"		✓				\$425
Windows, Door pair	114-6215-STK	.093"		✓				CALL
Window, Quarters, pair	114-6515-STK	.093"		✓				CALL
CHEVROLET CORVETTE: C7								
Window, Front	80145-63302	3/16"		✓				\$389
Window, Front	80145-63322	3/16"		✓				\$403
Window, Front	80145-63222	1/8"		✓				\$378
Window, Front	80145-63402	1/4"		✓				\$441
Window, Front	80145-63422	1/4"		✓				\$456
Window, Quarter, left or right	80145-65222LorR	1/8"		✓				\$29 ea
Window, Rear	80145-61202	1/8"		✓				\$257
Window, Rear	80145-61222	1/8"		✓				\$282
Window, Rear	80145-61302	3/16"		✓				\$289
Window, Rear	80145-61322	3/16"		✓				\$316

NOTE: All windows are molded and have a mar-resistant coating unless otherwise specified.

NEW LATE MODEL
ABC
LATE MODEL STOCK
NASCAR PRO SERIES
ARCA RACING SERIES
S2
PAVEMENT MODIFIED
SHORT TRACK TRUCK
STRAIGHT UP METAL
STREET STOCK
M3 DIRT LATE MODEL
M3 DIRT MODIFIED
DIRT GRAND NATIONAL
DRAG RACING
OFF ROAD
ROAD RACING
RACING WINDOWS
BODY ADD-ONS
FACTORY STOCK DIMENSION WINDOWS
85

DESCRIPTION	PART #	THICKNESS	OPTIONS					RACER
			OVERSIZE CUT TO FIT	BEVELED	DRILLED	COUNTERSUNK	BLACK OUT	
CHEVROLET CORVETTE: C6								
Headlight Covers	923-410HC	.093"	✓					\$82
Window, Front	923-6335-1	3/16"	✓					\$389
Window, Front	923-6335-2	3/16"		✓				\$403
Window, Front	923-6345-1	1/4"	✓					\$441
Window, Front	923-6345-2	1/4"		✓				\$456
Window, Front	923-6345-2B	1/4"		✓		✓		\$487
Window, Rear	923-6125-1	1/8"	✓					\$363
Window, Rear	923-6125-2	1/8"		✓				\$378
Window, Rear	923-6135-2B	3/16"		✓		✓		\$466
CHEVROLET CORVETTE: C5								
Window, Front	922-6325-1	1/8"	✓					\$363
Window, Front	922-6325-2	1/8"		✓				\$378
Window, Front	922-6335-1	3/16"	✓					\$389
Window, Front	922-6335-2	3/16"		✓				\$403
Window, Front	922-6345-1	1/4"	✓					\$441
Window, Front	922-6345-2	1/4"		✓				\$456
Window, Rear	922-6125-1	1/8"	✓					\$363
Window, Rear	922-6125-2	1/8"		✓				\$378
Window, Rear	922-6135-1	3/16"	✓					\$389
Window, Rear (Z06 style)	922-6135-1 Z06	3/16"	✓					\$289
Window, Rear	922-6135-2	3/16"		✓				\$434
CHEVROLET CORVETTE: C4								
Window, Front	920-6325-1	1/8"	✓					\$322
Window, Front	920-6325-2	1/8"		✓				\$336
Window, Front	920-6335-1	3/16"	✓					\$385
Window, Front	920-6335-2	3/16"		✓				\$400
Window, Front	920-6345-1	1/4"	✓					\$462
Window, Front	920-6345-2	1/4"		✓				\$477
Window, Rear	920-6125-1	1/8"	✓					\$322
Window, Rear	920-6125-2	1/8"		✓				\$336
Window, Rear	920-6135-1	3/16"	✓					\$385
Window, Rear	920-6135-2	3/16"		✓				\$400
CHEVROLET CORVETTE: 1963								
Window, Rear (trimmable to split window)	920-6125-SPLIT	1/8"	✓					\$207
CHEVROLET MONTE CARLO: 2000-2003								
Window, Front	324-6325	1/8"	✓					\$322
Window, Front	324-6335-1	3/16"	✓					\$385
Window, Front	324-6345-1	1/4"	✓					\$462
CHEVROLET MONTE CARLO: 1995-1999								
Window, Front	624-6325	1/8"						\$322
CHEVROLET MONTE CARLO: 1981-1988								
Window, Front	524-6325	1/8"	✓					\$322
Window, Front, flat	600-6303	1/8"		✓				\$212
Window, Rear, flat-uncoated	600-6101	.093"		✓				\$56
Window, Rear, flat	600-6105	.093"		✓				CALL
Window, Rear (Aero Coupe)	604-6125-A	1/8"	✓					\$338
CHEVROLET TRUCK C1500: 1999-2002								
Window, Front	T234-6335-1	3/16"	✓					CALL

NOTE: All windows are molded and have a mar-resistant coating unless otherwise specified.

DESCRIPTION	PART #	THICKNESS	OPTIONS					RACER
			OVERSIZE CUT TO FIT	BEVELED	DRILLED	COUNTERSUNK	BLACK OUT	
CHEVROLET TRUCK S10								
Window, Front	926-6335-1	3/16"	✓					\$385
DODGE VIPER GENERATION								
Window, Front	906-6335-1	3/16"	✓					\$385
Window, Front	906-6345-1	1/4"	✓					\$462
Window, Rear	906-6125	1/8"	✓					\$322
Window, Rear	906-6135	3/16"	✓					CALL
FORD MUSTANG: 2005-2009								
Window, Front	902-6325-STK	1/8"	✓					\$293
Window, Front	902-6335-STK	3/16"	✓					\$350
Window, Front	902-6345-STK	1/4"	✓					\$462
Window, Rear	902-6125-STK	1/8"	✓					\$322
Window, Rear	902-6135-STK	3/16"	✓					\$385
FORD MUSTANG: 1994-2004								
Window, Front	900-6325-1	1/8"	✓					\$322
Window, Front	900-6335-1	3/16"	✓					\$385
Window, Front	900-6345-1	1/4"	✓					\$462
Window, Rear	900-6125	1/8"	✓					\$322
Window, Rear	900-6135	3/16"	✓					\$385
FORD THUNDERBIRD: 1996-1997								
Window, Front	524-6335-1	3/16"	✓					\$385
Window, Front	524-6345-1	1/4"	✓					\$462
FORD F150 TRUCK: 1999-2002								
Window, Front	T254-6335-1	3/16"	✓					CALL
Window, Front	T254-6345-1	1/4"	✓					CALL
PONTIAC FIREBIRD: 1993-2002								
Window, Front	150-6325-2	1/8"		✓				\$350
Window, Front	150-6325-STK	1/8"	✓					\$363
Window, Front	150-6335-2	3/16"		✓				\$403
Window, Front	150-6335-STK	3/16"	✓					\$389
Window, Front	150-6345-STK	1/4"	✓					\$441
Window, Rear	150-6125-STK	1/8"	✓					\$363
Window, Rear	150-6135-STK	3/16"	✓					\$389
PONTIAC FIREBIRD: 1982-1992								
Window, Rear	110-6125	1/8"	✓					\$363
Window, Rear	110-6135	3/16"	✓					\$389
PONTIAC GRAND PRIX: 1996-2003								
Window, Front	324-6325	1/8"	✓					\$322
Window, Front	324-6335-1	3/16"	✓					\$385
Window, Front	324-6345-1	1/4"	✓					\$462
Window, Rear	324-6125	1/8"	✓					\$322
PONTIAC SOLSTICE								
Window, Front	905-6335-2	3/16"		✓				CALL

NOTE: All windows are molded and have a mar-resistant coating unless otherwise specified.

NEW LATE MODEL

ABC

LATE MODEL STOCK

NASCAR PRO SERIES

ARCA RACING SERIES

S2

PAVEMENT MODIFIED

SHORT TRACK TRUCK

STRAIGHT UP METAL

STREET STOCK

MD3 DIRT LATE MODEL

MD3 DIRT MODIFIED

DIRT GRAND NATIONAL

DRAG RACING

OFF ROAD

ROAD RACING

RACING WINDOWS

BODY ADD-ONS

FACTORY STOCK DIMENSION WINDOWS

DESCRIPTION	PART #	THICKNESS	OPTIONS				RACER
			OVERSIZE CUT TO FIT	BEVELED DRILLED	COUNTERSUNK	BLACKOUT	
BMW E30 COUPE: 1985-1991							
Window, Front	953-6345-2	1/4"	✓				\$477
Window, Quarter, pair	953-6525	1/8"	✓				\$196
Window, Rear	953-6135-2	3/16"	✓				\$353
Window, Rear	953-6135-2M	3/16"	✓				\$353
BMW E36 COUPE: 1992-1998							
Window, Front	951-6345-2	1/4"	✓				\$477
Window, Quarter, left or right	951-6525-2(L or R)	1/8"	✓				\$134 ea
Window, Rear	951-6135-2	3/16"	✓				\$413
BMW E36 SEDAN: 1992-1998							
Window, Front	951-6345-4	1/4"	✓				\$477
Window, Rear	951-6135-4	3/16"	✓				\$413
BMW E46 COUPE: 2000-2006							
Window, Front	952-6345-2	1/4"	✓				\$477
Window, Quarter, left or right	952-6525-2(L or R)	1/8"	✓				\$134 ea
Window, Rear	952-6135-2	3/16"	✓				\$413
MAZDA MIATA MX-5							
Window, Front	80771-63422	1/4"	✓			✓	\$477
PORSCHE 911							
Window, Front	911-6335-1	3/16"	✓				\$385
Window, Front	911-6335-2	3/16"	✓				\$400
Window, Front, C2/C4 models	911-6335-2C	3/16"	✓				CALL
Window, Front	911-6345-1	1/4"	✓				\$462
Window, Front	911-6345-2	1/4"	✓				\$477
Window, Front, C2/C4 models	911-6345-2C	1/4"	✓				\$477
Window, Rear	911-6125-1	1/8"	✓				\$257
Window, Rear	911-6125-2	1/8"	✓				\$271
Window, Rear	911-6125F	1/8"	✓				\$271
Window, Rear	911-6135-1	3/16"	✓				\$303
Window, Rear	911-6135-2	3/16"	✓				\$318
Window, Rear	911-6135F	3/16"	✓				\$318
PORSCHE 914							
Window, Front	943-6345-2	1/4"	✓				\$477
PORSCHE 944							
Window, Front	944-6345-1	1/4"	✓				\$462
Window, Front	944-6345-2	1/4"	✓				\$477
Window, Rear	944-6125-1	1/8"	✓				\$363
Window, Rear	944-6125-2	1/8"	✓				\$378
Window, Rear	944-6135-1	3/16"	✓				\$420
Window, Rear	944-6135-2	3/16"	✓				\$434
PORSCHE 991							
Window, Front	991-6345-2	1/4"	✓				\$477
PORSCHE 993							
Window, Front	993-6345-2	1/4"	✓				CALL
PORSCHE 996							
Window, Front	996-6335-2	3/16"	✓				\$400
Window, Front	996-6345-2	1/4"	✓				\$477
Window, Front	996-6345-2B	1/4"	✓			✓	\$519
Windows, Quarter, pair	996/7-6525-2	1/8"	✓				\$197
Window, Rear	996-6125-2	1/8"	✓				\$378
Window, Rear	996-6125-2B	1/8"	✓			✓	\$414

NOTE: All windows are molded and have a mar-resistant coating unless otherwise specified.

DESCRIPTION	PART #	THICKNESS	OPTIONS					RACER
			OVERSIZE CUT TO FIT	BEVELED DRILLED	COUNTERSUNK	BLACK OUT		
PORSCHE 997								
Window, Front	997-6335-2	3/16"	✓				\$400	
Window, Front	997-6345-2	1/4"	✓				\$477	
Window, Front	997-6345-2B	1/4"	✓		✓		\$519	
Windows, Quarter, pair	996/7-6525-2	1/8"	✓				\$197	
Window, Rear	997-6125-2	1/8"	✓				\$378	
PORSCHE BOXSTER, GEN 1								
Window, Front	994-6335-2	3/16"	✓				\$400	
Window, Front	994-6335-2B	3/16"	✓		✓		\$443	
Window, Front	994-6345-2	1/4"	✓				\$477	
Window, Front	994-6345-2B	1/4"	✓		✓		CALL	
PORSCHE CAYMAN: PRE-2014								
Window, Rear	911-6135-3	3/16"	✓				\$318	
PORSCHE CAYMAN: 2014+								
Window, Rear	911-6135-4	3/16"	✓				\$413	
ROAD RACING								
CHEVROLET CORVETTE: C6								
Headlight Covers, pair	923-410HC	.093"	✓				\$82	
Window, Front	923-6335-2A	3/16"	✓				\$403	
Window, Front	923-6345-2A	1/4"	✓				\$456	
SHORT TRACK								
UNIVERSAL								
Window, Front	000-6325	1/8"	✓				\$322	
Window, Front	000-6335-1	3/16"	✓				\$385	
Window, Front	000-6345-1	1/4"	✓				\$462	
Window, Front	564-6345-1	1/4"	✓				\$413	
Windows, Door Vent, pair	000-6202	.093"	✓				\$28	
Windows, Door, pair	000-6225	1/8"	✓				\$299	
Windows, Door, pair	000-6235	3/16"	✓				\$386	
Window, Rear, flat, blank	000-6102	.093"	✓				\$61	
SHORT TRACK TRUCK								
UNIVERSAL								
Window, Rear	21001-61151	.093	✓	✓	✓	✓	CALL	
Window, Rear	21001-61153	.093	✓	✓	✓	✓	CALL	
Window, Front	000-6302	1/8"	✓				\$122	
Window, Front	21001-63202	1/8"	✓				CALL	
Window, Front	21001-63253	1/8"	✓	✓	✓	✓	CALL	
CHEVROLET C1500: 2002								
Window, Front	T234-6325-1	1/8"	✓				\$287	
Window, Rear, flat-uncoated	T230-6101	.093"	✓				\$56	
FORD F-150: 2002								
Window, Front	T254-6325-1	1/8"	✓				\$287	
Window, Rear, flat-uncoated	T250-6101	.093"	✓				\$56	

NOTE: All windows are molded and have a mar-resistant coating unless otherwise specified.

NEW LATE MODEL
ABC
LATE MODEL STOCK
NASCAR PRO SERIES
ARCA RACING SERIES
S2
PAVEMENT MODIFIED
SHORT TRACK TRUCK
STRAIGHT UP METAL
STREET STOCK
M3 DIRT LATE MODEL
M3 DIRT MODIFIED
DIRT GRAND NATIONAL
DRAG RACING
OFF ROAD
ROAD RACING
RACING WINDOWS
BODY ADD-ONS

FACTORY STOCK DIMENSION-SHORT TRACK WINDOWS

**COMPLETE WINDOW PRODUCT LINE FOR
DRAG RACING AFTER MARKET - PRO MOD - PRO STOCK
PRO SPORTSMAN - DRAGSTER - FUNNY CAR**



**THE #1 WINDOWS USED
IN ALL MOTORSPORTS!**
WINDOWS MADE FROM OUR EXCLUSIVE OPTICAL
GRADE MATERIAL THAT NOBODY ELSE CAN OFFER!

 FIND MORE INFO ON OUR PREMIUM MATERIALS // PG 7!

DESCRIPTION	PART #	THICKNESS	OPTIONS					RACER
			OVERSIZE	CUT TO FIT	BEVELED	DRILLED	COUNTERSUNK	
AFTER MARKET								
CHEVROLET CORVETTE: 1963								
Window, Rear, pair (trim to split window)	920-6125-SPLIT	1/8"	✓				\$207	
CHEVROLET S-10 TRUCK								
Window, Front	926-6325-1	1/8"	✓				\$287	
FORD MUSTANG: 2005-2009								
▶ Indicates the component is included in the above Complete Package								
Window, Complete Package	902-600-1	1/8-3/16"					\$903	
▶ Windows, Door, pair	000-6235	3/16"	✓				\$344	
▶ Windows, Quarter, pair, 18" x 40"	000-6505	.093"	✓				\$62	
▶ Window, Rear	902-6125-1	1/8"	✓				\$261	
▶ Window, Front	902-6335-1	3/16"	✓				\$313	
Windows, Door, pair	000-6225	1/8"	✓				\$299	
PRO MOD								
CHEVROLET CAMARO: 1967-1969								
▶ Indicates the component is included in the above Complete Package								
Window, Complete Package	114-600-DRAG	1/8"					\$587	
▶ Window, Front	114-6325-DRAG	1/8"	✓				\$197	
▶ Windows, Door, left or right	114-6225-DRAG-(LorR)	1/8"	✓				\$70	
▶ Windows, Quarter, left or right	114-6525-DRAG-(LorR)	1/8"	✓				\$66	
▶ Window, Rear	114-6125-DRAG	1/8"	✓				\$197	
Window, Rear	114-6115-DRAG	.093"	✓				\$185	
CHEVROLET CAMARO: 2012								
▶ Indicates the component is included in the above Complete Package								
Window, Complete Package	960-600-2	1/8"-3/16"					\$1,220	
▶ Window, Front	960-6335-2	3/16"	✓	✓			\$369	
▶ Window, Door, left or right	960-6225-2(L or R)	1/8"	✓	✓			\$160 ea	
▶ Window, Quarter, left or right	960-6525-2(L or R)	1/8"	✓	✓	✓		\$110 ea	
▶ Window, Rear	960-6125-2	1/8"	✓	✓	✓		\$311	
FORD MUSTANG: 2005-2009								
▶ Indicates the component is included in the above Complete Package								
Window, Complete Package	902-600-2	1/8-3/16"					\$1,057	
▶ Window, Front	902-6335-2	3/16"	✓	✓	✓	✓	\$338	
▶ Window, Door, left or right	902-6225-2(L or R)	1/8"	✓	✓	✓	✓	\$143 ea	
▶ Window, Quarter, left or right	902-6525-2(L or R)	1/8"	✓	✓	✓	✓	\$72 ea	
▶ Window, Rear	902-6125-2	1/8"	✓				\$289	
PRO STOCK / PRO MOD								
CHEVROLET CAMARO: 2019								
▶ Indicates the component is included in the above Complete Package								
Window, Complete Package	64131-600-2	1/8-3/16"					\$1,220	
▶ Window, Front	64131-63332	3/16"	✓	✓			\$369	
▶ Window, Door, left or right	64131-62232(L or R)	1/8"	✓	✓			\$160 ea	
▶ Window, Quarter, left or right	64131-65242(L or R)	1/8"	✓	✓	✓		\$38 ea	
▶ Window, Rear	64131-61242	1/8"	✓	✓	✓		\$311	
Window, Front	64131-63232	1/8"	✓				\$348	
Window, Door, left or right	64131-62132(L or R)	.093"	✓	✓			\$132 ea	
Window, Quarter, left or right	64131-65142(L or R)	.093"	✓	✓	✓		\$36 ea	
Window, Rear	64131-61142	.093"	✓	✓	✓		\$240	

NOTE: All windows are molded and have a mar-resistant coating unless otherwise specified.

NEW LATE MODEL
ABC
LATE MODEL STOCK
NASCAR PRO SERIES
ARCA RACING SERIES
S2
PAVEMENT MODIFIED
SHORT TRACK TRUCK
STRAIGHT UP METAL
STREET STOCK
M3 DIRT LATE MODEL
M3 DIRT MODIFIED
DIRT GRAND NATIONAL
DRAG RACING
OFF ROAD
ROAD RACING
RACING WINDOWS
BODY ADD-ONS
DRAG RACING WINDOWS
91

OPTIONS

DESCRIPTION	PART #	THICKNESS	OPTIONS					RACER
			OVERSIZE	CUT TO FIT	BEVELED	DRILLED	COUNTERSINK	
CHEVROLET CAMARO: 2010-2016 > Indicates the component is included in the above Complete Package								
Window, Complete Package	961-600-2	1/8-3/16"						\$1,220
> Window, Front	961-6335-2	3/16"		✓	✓			\$369
> Window, Door, left or right	960-6225-2(L or R)	1/8"		✓	✓			\$174 ea
> Window, Quarter, left or right	960-6525-2(L or R)	1/8"		✓	✓	✓		\$119 ea
> Window, Rear	960-6125-2	1/8"		✓	✓	✓		\$340
Window, Front	961-6335-1	3/16"	✓					\$379
Window, Door, left or right	960-6215-2(L or R)	.093"		✓	✓			\$132
Window, Quarter, left or right	960-6515-2(L or R)	.093"		✓	✓	✓		\$87 ea
Window, Quarter, left or right	960-6525-2(L or R)	1/8"		✓	✓	✓		\$119 ea
Window, Rear	960-6115-2	.093"		✓	✓	✓		\$240
CHEVROLET CAVALIER > Indicates the component is included in the above Complete Package								
Window, Complete Package	903-600-1	1/8-3/16"						\$1,088
> Window, Front	904-6335-1	3/16"		✓				\$344
> Window, Door, left or right	904-6225(L or R)	1/8"		✓				\$144 ea
> Window, Quarter, left or right	903-6525	1/8"		✓				\$85 ea
> Window, Rear	904-6125	1/8"		✓				\$286
CHEVROLET COBALT > Indicates the component is included in the above Complete Package								
Window, Complete Package	913-600-1	1/8-3/16"						\$1,088
> Window, Front	913-6335-1	3/16"		✓				\$344
> Window, Door, left or right	913-6225(L or R)	1/8"		✓				\$131 ea
> Window, Quarter, left or right	913-6525(L or R)	1/8"		✓				\$98 ea
> Window, Rear	913-6125	1/8"		✓				\$286
Window, Complete Package	913-600-2	1/8-3/16"						\$1,186
> Window, Front	913-6335-2	3/16"		✓	✓			\$369
> Window, Door, left or right	913-6225-2(L or R)	1/8"		✓	✓			\$143 ea
> Window, Quarter, left or right	913-6525-2(L or R)	1/8"		✓	✓	✓		\$110 ea
> Window, Rear	913-6125-2	1/8"		✓	✓	✓		\$311
DODGE AVENGER > Indicates the component is included in the above Complete Package								
Window, Complete Package	909-600-2	1/8-3/16"						\$999
> Window, Front	909-6335-2	3/16"		✓	✓	✓		\$369
> Window, Door, left or right	909-6225-2(L or R)	1/8"		✓	✓	✓		\$94 ea
> Window, Quarter, left or right	909-6525-2(L or R)	1/8"		✓	✓	✓		\$85 ea
> Window, Rear	909-6125-2	1/8"		✓	✓	✓		\$272
Window, Front, trim at base	909-6335-1	3/16"	✓					\$344
DODGE DART > Indicates the component is included in the above Complete Package								
Window, Complete Package	910-600-2	1/8-3/16"						\$1,224
> Window, Front	910-6335-2	3/16"		✓	✓			\$404
> Window, Door, left or right	910-6225-2(L or R)	1/8"		✓	✓			\$174 ea
> Window, Quarter, left or right	910-6525-2(L or R)	1/8"		✓	✓	✓		\$107 ea
> Window, Rear	910-6135-2	3/16"		✓	✓	✓		\$369
Window, Front	910-6325-2	1/8"		✓	✓			\$348
Window, Door, left or right	910-6215-2(L or R)	.093"		✓	✓			\$132 ea
Window, Quarter, left or right	910-6515-2(L or R)	.093"		✓	✓	✓		\$84 ea
Window, Rear	910-6115-2	.093"		✓	✓	✓		\$264
Window, Rear	910-6125-2	1/8"		✓	✓	✓		\$340
Window, Rear	910-6135-2	3/16"		✓	✓	✓		\$369

NOTE: All windows are molded and have a mar-resistant coating unless otherwise specified.

NEW LATE MODEL
ABC
LATE MODEL STOCK
NASCAR PRO SERIES
ARCA RACING SERIES
S2
PAVEMENT MODIFIED
SHORT TRACK TRUCK
STRAIGHT UP METAL
STREET STOCK
M3 DIRT LATE MODEL
M3 DIRT MODIFIED
DIRT GRAND NATIONAL
DRAG RACING
OFF ROAD
ROAD RACING
RACING WINDOWS
BODY ADD-ONS

DESCRIPTION	PART #	THICKNESS	OPTIONS					RACER
			OVERSIZE	CUT TO FIT	BEVELED	DRILLED	COUNTERSINK	
DODGE NEON > Indicates the component is included in the above Complete Package								
Window, Complete Package	907-600-1A	1/8-3/16"						\$918
> Window, Front	907-6335-1	3/16"	✓					\$344
> Windows, Door & Quarter, left or right	907-6225(L or R)	1/8"	✓					\$144 ea
> Window, Rear	907-6125	1/8"	✓					\$286
DODGE STRATUS > Indicates the component is included in the above Complete Package								
Window, Complete Package	908-600-1A	1/8-3/16"						\$1,114
> Window, Front	908-6335-1	3/16"	✓					\$344
> Window, Door, left or right	908-6225(L or R)	1/8"	✓					\$144 ea
> Window, Quarter, left or right	908-6525(L or R)	1/8"	✓					\$98 ea
> Window, Rear	908-6125	1/8"	✓					\$286
Window, Rear	908-6135	3/16"	✓					\$344
FORD MUSTANG: 2010 > Indicates the component is included in the above Complete Package								
Window, Complete Package	901-600-2	1/8-3/16"						\$1,110
> Window, Front	901-6335-2	3/16"		✓	✓			\$369
> Window, Door, left or right	901-6225-2(L or R)	1/8"		✓	✓			\$143 ea
> Window, Quarter, left or right	901-6525-2(L or R)	1/8"		✓	✓			\$72 ea
> Window, Rear	901-6125-2	1/8"		✓	✓	✓		\$311
FORD MUSTANG: 2016 > Indicates the component is included in the above Complete Package								
Window, Complete Package	64321-600-2	1/8, 3/16"						\$1,220
> Window, Front	64321-63302	3/16"	✓					\$344
> Window, Door, left or right	64321-62232(L or R)	1/8"		✓	✓			\$160 ea
> Window, Quarter, left or right	64321-65242(L or R)	1/8"		✓	✓	✓		\$110 ea
> Window, Rear	64321-61242	1/8"		✓	✓	✓		\$311
Window, Front	64321-63232	1/8"		✓	✓			\$311
Window, Front	64321-63332	3/16"		✓	✓			\$369
Window, Door, left or right	64321-62132(L or R)	.093"		✓	✓			\$121 ea
Window, Quarter, left or right	64321-65142(L or R)	.093"		✓	✓	✓		\$80 ea
Window, Rear	64321-61142	.093"		✓	✓	✓		\$200
PONTIAC GRAND AM > Indicates the component is included in the above Complete Package								
Window, Complete Package	904-600-1	1/8-3/16"						\$1,088
> Window, Front	904-6335-1	3/16"	✓					\$344
> Window, Door, left or right	904-6225(L or R)	1/8"	✓					\$144 ea
> Window, Quarter, left or right	904-6525(L or R)	1/8"	✓					\$85 ea
> Window, Rear	904-6125	1/8"	✓					\$286
PONTIAC GTO > Indicates the component is included in the above Complete Package								
Headlight Covers, pair	914-410HC	.093"	✓					\$56
Window, Complete Package	914-600-1	1/8-3/16"						\$1,088
> Window, Front	914-6335-1	3/16"	✓					\$344
> Window, Door, left or right	914-6225(L or R)	1/8"	✓					\$131 ea
> Window, Quarter, left or right	914-6525(L or R)	1/8"	✓					\$98 ea
> Window, Rear	914-6125	1/8"	✓					\$286
Window, Complete Package	914-600-2	1/8-3/16"						\$1,186
> Window, Front	914-6335-2	3/16"		✓	✓			\$369
> Window, Door, left or right	914-6225-2(L or R)	1/8"		✓	✓			\$143 ea
> Window, Quarter, left or right	914-6525-2(L or R)	1/8"		✓	✓	✓		\$110 ea
> Window, Rear	914-6125-2	1/8"		✓	✓	✓		\$311

NOTE: All windows are molded and have a mar-resistant coating unless otherwise specified.

 FIND WINDOW PRODUCTS & INSTALL KITS // PG 105,111,115 & 122!

DRAG RACING WINDOWS

DESCRIPTION	PART #	THICKNESS	OPTIONS					RACER
			OVERSIZE CUT TO FIT	BEVELED	DRILLED	COUNTERSUNK	BLACK OUT	
PONTIAC GXP								
▶ Indicates the component is included in the above Complete Package								
Window, Complete Package	924-600-1	1/8-3/16"						\$1,088
▶ Window, Front	924-6335-1	3/16"	✓					\$344
▶ Window, Door, left or right	924-6225(L or R)	1/8"	✓					\$131 ea
▶ Window, Quarter, left or right	924-6525(L or R)	1/8"	✓					\$98 ea
▶ Window, Rear	924-6125	1/8"	✓					\$286
Window, Complete Package	924-600-2	1/8-3/16"						\$1,186
▶ Window, Front	924-6335-2	3/16"	✓	✓				\$369
▶ Window, Door, left or right	924-6225-2(L or R)	1/8"	✓	✓				\$143 ea
▶ Window, Quarter, left or right	924-6525-2(L or R)	1/8"	✓	✓	✓			\$110 ea
▶ Window, Rear	924-6125-2	1/8"	✓	✓	✓			\$311
DRAGSTER								
STANDARD								
Window, Front, standard, 12" tall	931-6325-1	1/8"	✓					\$221
Window, Front, standard, 9" tall	931-6325-1A	1/8"	✓					\$198
Window, Front, standard, 7" tall	931-6325-1B	1/8"	✓					\$179
Window, Front, wide, 12" tall	931-6325-2M	1/8"	✓					\$221
<i>(WINDOW, FRONTS are 18" wide across the bottom. Standard Window, Fronts are 14" wide across the top. Wide Window, Fronts are 16" wide across the top)</i>								
FUNNY CAR								
CHEVROLET CAMARO								
Window, Complete Package	68131-600-2	1/8-3/16"						\$622
▶ Window, Front	68131-63352	3/16"	✓	✓	✓	✓		\$402
▶ Window, Doors, pair	68131-62252	1/8"	✓	✓	✓	✓		\$220
Window, Front	68131-63452	1/4"	✓	✓	✓	✓		\$458
CHEVROLET IMPALA								
Window, Front	933-6335-2	3/16"	✓	✓				\$402
Window, Doors, pair	933-6225-2	1/8"	✓	✓				\$220
Window, Doors, pair	933-6235-2	3/16"	✓	✓				\$225
CHEVROLET MONTE CARLO								
Window, Front	930-6335-2	3/16"	✓	✓				\$286
Window, Doors, pair	930-6225-2	1/8"	✓	✓				\$220
DODGE CHARGER								
Window, Front	932-6335-2	3/16"	✓	✓				\$402
Window, Front	932-6345-2	1/4"	✓	✓				\$508
Window, Doors, pair	932-6225-2	1/8"	✓	✓				\$220
Window, Doors, pair (has fire hole)	932-6235-2	3/16"	✓	✓				\$250
FORD MUSTANG								
Window, Front	929-6335-2	3/16"	✓	✓				\$286
Window, Doors, pair	929-6225-2	1/8"	✓	✓				\$220
TOYOTA								
Window, Front	934-6345-2	1/4"	✓	✓	✓			\$458
Window, Front	934-6345-3	1/4"	✓	✓	✓	✓		\$458
Window, Doors, pair	934-6235-2	3/16"	✓	✓				\$250
Window, Doors, pair (has fire hole)	934-6235-3	3/16"	✓	✓	✓	✓		\$266
NOTE: All windows are molded and have a mar-resistant coating unless otherwise specified.								

 FIND WINDOW PRODUCTS & INSTALL KITS // PG 105,111,115 & 122!

LEARN MORE ABOUT FIVE STAR'S NOSES, BUMPER COVERS & ACCESSORIES



HIGH-IMPACT MOLDED PLASTIC NOSES & BUMPER COVERS

UNSURPASSED IMPACT RESISTANCE & DURABILITY!

- Five Star uses our own state-of-the-art proprietary blend of plastic material that is Ultra-durable, light weight and holds up in the toughest racing conditions
- Engineered high elongation provides superior flexibility while maintaining structural integrity
- Available in (5) colors! **B** **CB** **R** **W** **Y**



UPPER & LOWER NOSE SCREENS

- Frame is CNC-machined from light weight quality aluminum
- Screen is high strength stainless steel (3/4" mesh is crimped, 1/4" is welded)
- Available unpainted or with durable satin black powder-coat finish

VINYL NOSE & TAIL GRAPHICS ID KITS

GET THE OEM LOOK WITH OUTSTANDING REALISTIC DETAILS DESIGNED FOR ALL MAJOR MANUFACTURERS!

- Printed on 6-year outdoor durable high-tack vinyl with aggressive adhesive
- Glossy laminated surface provides excellent sandblast and chemical protection!
- All kits include mounting instructions, realistic emblems and Five Star decals!

 **FIND COMPLETE LIST OF NOSES, BUMPER COVERS & ACCESSORIES // PG 96-99**

HIGH-IMPACT MOLDED PLASTIC '04-UP NOSES & BUMPER COVERS

VISIT FIVESTARBODIES.COM FOR BODY MOUNTING GUIDELINES, TEMPLATES AND MORE!

CHEVROLET SS

-B **-W**

-CB **-R** **-Y**

660-410-x	Nose	\$123	\$128
680-410-ID	Nose ID Kit	\$32	\$32
460-450-x	Bumper Cover	\$113	\$118
680-450-ID	Tail ID Kit	\$26	\$26



CHEVROLET CAMARO

-B **-W**

-CB **-R**

11132-41051-x	Nose	\$120	\$125
11132-44141	Nose ID Kit	\$32	\$32
11002-45051-x	Bumper Cover	\$111	\$118
11132-44541	Tail ID Kit	\$26	\$26



FORD FUSION

-B **-W**

-CB **-R** **-Y**

570-410-x	Nose	\$123	\$128
500-410-ID	Nose ID Kit	\$32	\$32
460-450-x	Bumper Cover	\$113	\$118
500-450-ID	Tail ID Kit	\$26	\$26



FORD MUSTANG

-B **-W**

-CB **-R**

11332-41051-x	Nose	\$120	\$125
11332-44141	Nose ID Kit	\$32	\$32
11002-45051-x	Bumper Cover	\$111	\$118
11332-44541	Tail ID Kit	\$26	\$26



TOYOTA CAMRY

-B **-W**

-CB **-R** **-Y**

720-410-x	Nose	\$123	\$128
740-410-ID	Nose ID Kit	\$32	\$32
460-450-x	Bumper Cover	\$113	\$118
740-450-ID	Tail ID Kit	\$26	\$26



TOYOTA CAMRY

-B **-W**

-CB **-R**

11712-41051-x	Nose	\$120	\$125
11712-44141	Nose ID Kit	\$32	\$32
11002-45051-x	Bumper Cover	\$111	\$118
11712-44541	Tail ID Kit	\$26	\$26



DODGE CHARGER

-B **-W** **-CB** **-R** **-Y**

470-410-x	Nose	\$123	N/A
470-410-ID	Nose ID Kit	\$32	\$32
460-450-x	Bumper Cover	\$113	\$118
470-450-ID	Tail ID Kit	\$26	\$26



PONTIAC GRAND PRIX

-B **-W** **-CB** **-R** **-Y**

360-410-x	Nose	\$123	N/A
360-410-ID	Nose ID Kit	\$32	\$32
460-450-x	Bumper Cover	\$113	\$118
360-450-ID	Tail ID Kit	\$26	\$26



-B **-W**

LOWER NOSE SCREENS

LATE MODEL/ABC/LMSC/STRAIGHT-UP METAL/DIRT GRAND NATIONAL

660-4112 (1/4" mesh, unpainted)	\$47
660-4111 (3/16" mesh, unpainted)	\$47
660-4112-B (1/4" mesh, black)	\$52
660-4111-B (3/16" mesh, black)	\$52



UPPER NOSE SCREENS

DIRT GRAND NATIONAL

66A-4131 Chevrolet SS Nose, upper (3/16" mesh, unpainted)	\$51
720-4131 Camry Nose, upper (3/16" mesh, unpainted)	\$51
360-4131 Grand Prix Nose, upper (3/16" mesh, unpainted)	\$54



**UNMATCHED DURABILITY
& SHAPE CONSISTENCY**

MADE WITH OUR OWN SPECIAL BLEND OF PLASTIC!

FIND MORE INFO ON OUR PREMIUM BODY MATERIALS // PG 4-7!



VISIT OUR WEBSITE FOR BODY MOUNTING GUIDELINES, TEMPLATES AND MORE!
*PRICES & PART NUMBERS SUBJECT TO CHANGE WITHOUT NOTICE.

HIGH-IMPACT MOLDED PLASTIC '03-OLDER NOSES & BUMPER COVERS

VISIT FIVESTARBODIES.COM FOR BODY MOUNTING GUIDELINES, TEMPLATES AND MORE!

'03 CHEVROLET MONTE CARLO

-B **-W**

640-410-BorW	Nose: Black or White	\$135
630-410-ID	Nose ID Kit	\$32
630-450-BorW	Bumper Cover: Black or White	\$113



'99 CHEVROLET MONTE CARLO

-B **-W**

620-410-BorW	Nose: Black or White	\$135
620-410-ID	Nose ID Kit	\$32
620-450-BorW	Bumper Cover: Black or White	\$124
620-450-ID	Tail ID Kit	\$26



'88 CHEVROLET MONTE CARLO

-B **-W** **-CB** **-OR** **-R** **-Y**

600-410-x	Nose, Classic	\$119
021-410-x	Nose, MD3	\$119
600-410-ID	Nose ID Kit, Classic	\$32
021-410-ID	Nose ID Kit, MD3	\$32
021-450-x	Bumper Cover, MD3	\$119
021-450-ID	Tail ID Kit	\$26

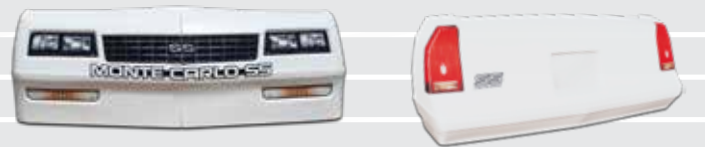

'03 FORD TAURUS

-B **-W**

550-410-BorW	Nose: Black or White	\$135
550-410-ID	Nose ID Kit	\$32
550-450-BorW	Bumper Cover: Black or White	\$124



'97 CHEVROLET CAMARO

-B **-W**

150-410-W	Nose: White	\$202
150-450-W	Bumper Cover: White	\$119



'92 CHEVROLET CAMARO

-B **-W**

140-410-BorW	Nose Pavement: Black or White	\$141
140-410-ID	Nose ID Kit	\$32
140-450-BorW	Bumper Cover: Black or White	\$98



'92 CHEVROLET CAMARO

-B **-W**

145-410-BorW	Nose Dirt: Black or White	\$141
145-410-ID	Nose ID Kit	\$32



'93 FORD MUSTANG MINI STOCK

-B **-W**

915-410-BorW	Nose: black or white	\$130
915-450-BorW	Bumper Cover: black or white	\$123



'81 CHEVROLET CAMARO

-B **-W**

210-410U	Nose: Upper, black	\$76
210-410L	Nose: Lower, black	\$57



'94 CHEVROLET LUMINA

-B **-W**

610-410-W	Nose: White	\$135
610-450-BorW	Bumper Cover: Black or White	\$124



'97 FORD THUNDERBIRD

-B **-W**

530-410-W	Nose: White	\$135
530-450-W	Bumper Cover: White	\$124



'88 FORD THUNDERBIRD

-B **-W**

510-410-BorW	Nose: Black or White	\$135
--------------	----------------------	-------



'97 PONTIAC FIREBIRD

-B **-W**

180-410-W	Nose: White	\$141
-----------	-------------	-------



**UNMATCHED DURABILITY
& SHAPE CONSISTENCY**

MADE WITH OUR OWN SPECIAL BLEND OF PLASTIC!

FIND MORE INFO ON OUR PREMIUM BODY MATERIALS // PG 4-7!



VISIT OUR WEBSITE FOR BODY MOUNTING GUIDELINES, TEMPLATES AND MORE!
*PRICES & PART NUMBERS SUBJECT TO CHANGE WITHOUT NOTICE.

BODY MOUNTING KITS

EVERYTHING YOU NEED TO MOUNT A NEW BODY!!

NEW LATE MODEL **ALL NEW** BODY MOUNTING KIT

- Braces, body, adjustable (3) pkgs (PN 807-3)
- Brace Kit, Window, rear (PN 11002-76133)
- Brace Kit, Windshield (PN 11002-76333)
- Bumper, front, 1 3/4", .065" steel, (PN 11002-71182)
- Bumper Mounting Kit, front (PN 802-5)
- Bumper, rear (PN 11002-71682)
- Bumper Mounting Kit, rear (PN 802-2S)
- Door Support, right side (PN 11002-75533)
- Hood Pin Bracket, standard (PN11002-34331)
- Hood Pin Kit, 1/2" pins (PN 803)
- Rear Deck Mounting Kit (PN 660-450-RDK)
- Screen, nose, stainless, 3/16" (PN 660-4111)
- Window Installation Kit (PN 805)
- Windows, Door Vent (PN 11002-66222)
- Graphics, Nose ID kit (specify body style)
- Graphics, Tail ID kit (specify body style)
- Nose Braces (PN 11002-75333)
- Wear Strip Attaching Kit (PN 000-400K)
- Wear Strips (PN 11002-41551-color)

Description	PN	RACER
New Late Model Body Mounting Kit	11002-72520	\$763.50
Body Mounting Kit Upgrades	PN	+ TO PKG \$
Bumper, front, .095" steel, 1 3/4" round	11002-71185	\$0
Bumper, front, .095" steel, w/12" extension	11002-71188	+\$9
Hood Pin Bracket, 3/4" aluminum	11002-34333	+\$33
Hood Pin Kit, 3/8" pins	803-A	\$0
Screen, nose, 1/4" spacing	660-4112	\$0
Screen, nose, black 3/16" spacing	660-4111-B	+\$5
Screen, nose, black 1/4" spacing	660-4112-B	+\$5



SHORT TRACK TRUCK **ALL NEW** BODY MOUNTING KIT

- Braces, body, adjustable (3) pkgs (PN 807-3)
- Brace Kit, Winshield (PN 21001-76333)
- Bumper, front, 1 1/2", .065" steel, (PN 21001-71162)
- Bumper Mounting Kit, front (PN 802-5)
- Bumper, rear (PN T000-7503)
- Bumper Mounting Kit, rear (PN 802-2S)
- Door Support, right side (PN 11002-75533)
- Hood Pin Bracket, standard (PN 21001-34131)
- Hood Pin Kit, 1/2" pins (PN 803)
- Screen, nose, stainless, 1/4" (PN 81001-46433B)
- Window Installation Kit (PN 805)
- Graphics, Nose ID kit (specify body style)
- Graphics, Tail ID kit (specify body style)

Description	PN	RACER
Short Track Truck Body Mounting Kit	21001-72521	\$526

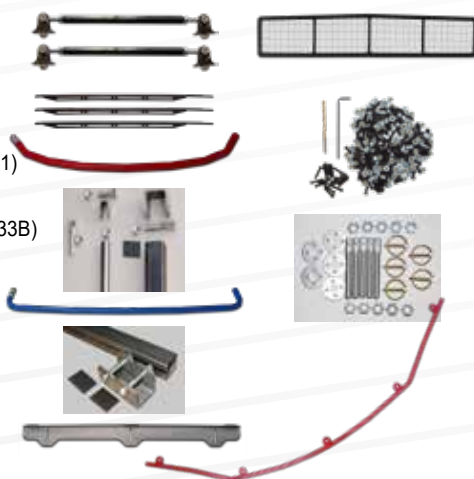

*graphics included-photo coming soon!

ABC BODY MOUNTING KIT

- Braces, body, adjustable (3) pkgs (PN 807-3)
- Brace Kit, Window, rear (PN 674-6101)
- Brace Kit, Windshield (PN 564-6301)
- Bumper, front, 1 1/4", .065" steel, (PN 660-7103)
- Bumper Mounting Kit, front (PN 802-5)
- Bumper, rear (PN 570-7503)
- Bumper Mounting Kit, rear (PN 802-2S)
- Door Support, right side (PN 11002-75533)
- Hood Pin Bracket, standard (PN xx0-410-HPB)
- Hood Pin Kit, 1/2" pins (PN 803)
- Rear Deck Mounting Kit (PN 660-450-RDK)
- Screen, nose, stainless, 3/16" (PN 660-4111)
- Window Installation Kit (PN 805)
- Windows, Door Vent (PN 000-6202)
- Graphics, Nose ID kit (specify body style)
- Graphics, Tail ID kit (specify body style)
- Nose Braces (PN 000-500)
- Wear Strip Attaching Kit (PN 000-400K)
- Wear Strips (PN 000-400-color)

Description	PN	RACER
ABC Body Mounting Kit	800-1D	\$813
Body Mounting Kit Upgrades	PN	+ TO PKG \$
Bumper, front, .095" steel, 1 1/4" round	660-7103B	\$0
Bumper, front, .095" steel, w/12" extension	660-7103C	+\$8
Hood Pin Bracket, 3/4"	xx0-411-HPB	+\$3
Hood Pin Kit, 3/8" pins	803-A	\$0
Hood Pin Bracket, 3/4" aluminum	xx0-411A-HPB	\$35
Screen, nose, 1/4" spacing	660-4112	\$0
Screen, nose, black 3/16" spacing	660-4111-B	+\$5
Screen, nose, black 1/4" spacing	660-4112-B	+\$5



OTHER FIVE STAR RECOMMENDED BODY MOUNTING PRODUCTS:



DETAILS » PG 106

ROOF LOCATING FIXTURE

THE FASTEST, EASIEST WAY TO MOUNT YOUR OWN BODY!



DETAILS » PG 110

CUSTOM BODY BRACE KIT

USE ANYWHERE BRACING IS NEEDED!



DETAILS » PG 110

TELESCOPING BODY BRACES

FULLY ADJUSTABLE UP TO 4" AND USE ANYWHERE BRACING IS NEEDED!



DETAILS » PG 108

POLYCARBONATE BODY BRACES

STIFF ENOUGH TO SUPPORT PANELS, YET RETAIN FLEXIBILITY IF HIT!

VISIT OUR WEBSITE FOR BODY MOUNTING GUIDELINES, TEMPLATES AND MORE!
*PRICES & PART NUMBERS SUBJECT TO CHANGE WITHOUT NOTICE.

BODY MOUNTING KITS

EVERYTHING YOU NEED TO MOUNT A NEW BODY!!

LMSC BODY MOUNTING KIT

- › Braces, body, adjustable (2) pkgs (PN 807-3)
- › Brace Kit, Window, rear (PN 674-6101)
- › Brace Kit, Windshield (PN 564-6301)
- › Bumper, front, 1 3/4", .065" steel, (PN 660-7103)
- › Bumper Mounting Kit, front (PN 802-5)
- › Bumper, rear (PN 570-7503)
- › Bumper Mounting Kit, rear (PN 802-2S)
- › Hood Pin Bracket, standard (PN xx0-410-HPB)
- › Hood Pin Kit, 1/2" pins (PN 803)
- › Rear Deck Mounting Kit (PN 660-450-RDK)
- › Screen, nose, stainless, 3/16" (PN 660-4111)
- › Window Installation Kit (PN 805)
- › Windows, Door Vent (PN 000-6202)
- › Graphics, Nose ID kit (specify body style)
- › Graphics, Tail ID kit (specify body style)
- › Nose Braces (PN 000-500)
- › Wear Strip Attaching Kit (PN 000-400K)
- › Wear Strips (000-400-color)

Description	PN	RACER
LMSC Body Mounting Kit	800-3D	\$750
Body Mounting Kit Upgrades	PN	+ TO PKG \$
Bumper, front, .095" steel, 1 3/4" round	660-7103B	\$0
Bumper, front, .095" steel, w/12" wraparound	660-7103C	+\$8
Hood Pin Bracket, 3/4"	xx0-411-HPB	+\$3
Hood Pin Kit, 3/8" pins	803-A	\$0
Hood Pin Bracket, 3/4" aluminum	xx0-411A-HPB	+\$35
Screen, nose, 1/4" spacing	660-4112	\$0
Screen, nose, black 3/16" spacing	660-4111-B	+\$5
Screen, nose, black 1/4" spacing	660-4112-B	+\$5



VISIT FIVESTARBODIES.COM FOR DIMENSION SHEETS, INSTALLATION TIPS & MORE...

FIVE STAR body rules & dimensions

PDF format requires Adobe Acrobat or Acrobat Reader. Click [HERE](#) to download Acrobat Reader.

[Download Body Rules](#)
[Download ABC Tech Inspection Checklist](#)

- 2004-2014 Late Model Body
- ABC
- Late Model Truck Car (2-RR)
- 52 Suspension
- Short Track Trucks
- Brackets w/ Metal
- Steel Brakes
- Don't Grand National
- Flanged Suspension
- Single w/ Flanges
- Nose & Bumper Center Alignment
- Pre-Stock - Pre-Mod 2014 Chassis
- Pre-Mod 2011 Chassis
- DR Road Trucks
- Steel Body Centers
- Road Racing Mustang

INSTALLATION tips

PDF format, requires Adobe Acrobat or Acrobat Reader. Click [HERE](#) to download Acrobat Reader.

- US Radiator Air Box Assembly Instructions
- Heat Shield (for Cold Air Box) Installation Instructions
- Roof Locating Fixture Assembly Instructions

S2 SPORTSMAN BODY MOUNTING KIT

- Braces, body, adjustable (3) pkgs (PN 807-3)
- Brace Kit, Window, rear (PN 674-6101)
- Brace Kit, Windshield (PN 664-6301)
- Bumper, front, 1 1/4", .065" steel, (PN 660-7103)
- Bumper Mounting Kit, front (PN 802-5)
- Bumper, rear (PN 570-7503)
- Bumper Mounting Kit, rear (PN 802-2S)
- Door Support, right side (PN 11002-75533)
- Hood Pin Bracket, standard (PN 664-410-HPB)
- Hood Pin Kit, 1/2" pins (PN 803)
- Rear Deck Mounting Kit (PN 660-450-RDK)
- Screen, nose, stainless, 3/16" (PN 664-4111)
- Window Installation Kit (PN 805)
- Graphics, Nose ID kit (specify body style)
- Graphics, Tail ID kit (specify body style)
- Nose Braces (PN 000-500)
- Wear Strip Attaching Kit (PN 000-400K)
- Wear Strips (PN 664-400-color)

Description	PN	RACER
S2 Sportsman Body Mounting Kit	800-2D	\$770
Body Mounting Kit Upgrades	PN	+ TO PKG \$
Bumper, front, .095" steel, 1 1/4" round	664-7103B	\$0
Hood Pin Bracket, 3/4"	664-411-HPB	+\$3
Hood Pin Kit, 3/8" pins	803-A	\$0
Screen, nose, 1/4" spacing	664-4112	\$0
Screen, nose, black 3/16" spacing	664-4111-B	+\$5
Screen, nose, black 1/4" spacing	664-4112-B	+\$5



BODY MOUNTING KITS

OTHER FIVE STAR RECOMMENDED BODY MOUNTING PRODUCTS:



DETAILS » PG 106

ROOF LOCATING FIXTURE

THE FASTEST, EASIEST WAY TO MOUNT YOUR OWN BODY!



DETAILS » PG 110

TELESCOPING BODY BRACES

FULLY ADJUSTABLE UP TO 4" AND USE ANYWHERE BRACING IS NEEDED!

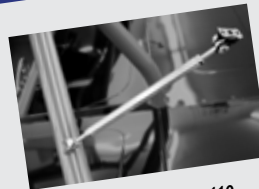

DETAILS » PG 110

CUSTOM BODY BRACE KIT

USE ANYWHERE BRACING IS NEEDED!



DETAILS » PG 108

POLYCARBONATE BODY BRACES

STIFF ENOUGH TO SUPPORT PANELS, YET RETAIN FLEXIBILITY IF HIT!

VISIT OUR WEBSITE FOR BODY MOUNTING GUIDELINES, TEMPLATES AND MORE!
*PRICES & PART NUMBERS SUBJECT TO CHANGE WITHOUT NOTICE.

BODY MOUNTING COMPONENTS

EVERYTHING YOU NEED TO MOUNT BODY PANELS!

MULTI-GRIP FIVE STAR PREMIUM RIVETS

EXTREMELY TIGHT GRIP AND WON'T SPIN WHILE DRILLING OUT!

- ▶ These multi-grip rivets provide a super tight hold by expanding in the hole to prevent loose body panels
- ▶ Grip range of up to 1/2"
- ▶ Sold in quantities of (100) & (500); large head & small head
- ▶ Choice of 3/16" in yellow, blue, red, black, white (to match our colored bodies) & unpainted
- ▶ 1/8" unpainted
- ▶ Optional Five Star Back-up Washers are recommended for attaching plastic body panels

THE BEST RIVETS ON THE MARKET!



Description	QTY	SM HEAD	LG HEAD	RACER
3/16", color	100	814color-100S	814color-100L	\$13
3/16", unpainted	100	816-100S	816-100L	\$10
3/16" Long Shank ¹	100	816A-100S	n/a	\$15
3/16" Peel-style ²	100	816P-100S	n/a	\$24
3/16", color	500	814color-500S	814color-500L	\$55
3/16", unpainted	500	816-500S	816-500L	\$43
1/8", unpainted	100	815-100S	815-100L	\$7
1/8", unpainted	500	815-500S	815-500L	\$29

¹ Use Long Shank rivets for fastening fender, door & windshield post together

² Peel Rivets do not require back-up washers. Use them in areas where there is no room to position a washer

**FIVE STAR'S RIVETS
PULL MUCH TIGHTER
THAN OTHER CHEAPER
QUALITY RIVETS!**

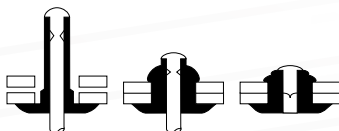

LIGHTWEIGHT ALUMINUM FIVE STAR PREMIUM WASHERS

- ▶ Oversized to fit Five Star Premium Rivets

Description	SIZE	QTY	PART #	RACER
standard	1/8"	100	817-100A	\$4
standard	1/8"	500	817-500A	\$14
standard	3/16"	100	818-100A	\$4
standard	3/16"	500	818-500A	\$16
large	3/16"	100	818-100AL	\$5
large	3/16"	500	818-500AL	\$17

SPOILER MOUNTING KIT

- ▶ Everything you need to cleanly mount polycarbonate spoilers
- ▶ Contains light weight machined aluminum washers

PART #	RACER
000-67K	9oz \$33



▶ Sold separately, see pg 108

RIVET & CLECO DRILL BIT KIT

HIGH QUALITY, LONG LASTING DRILL BIT IDEAL FOR RIVET AND CLECO INSTALLATION!

- Slightly larger diameter hole than a standard 1/8" or 3/16" bit
- Short drill shaft makes drilling in tight places easier
- Contains: (2) 9/64" and (2) #30 double-ended drill bits

PART #	RACER	
806	\$23	



HIGH SPEED COUNTERSINK DRILL BIT

- 3/8" diameter steel bit, 1/4" shank
- Use for countersinking installation screws into polycarbonate
- Not required for pre-cut to fit, beveled & drilled windows

PART #	RACER	
805-1	1/4" shank	\$18



HEAVY DUTY CLECOS & PLIERS

SPECIFICALLY DESIGNED TO HOLD EVEN IF HOLE BECOMES ENLARGED OR ELONGATED!

- Choice of 1/8" single spade, long, or 3/16" single spade, long, quantity of (25)
- Use Five Star Cleco Pliers for ease of installation!

PART #	RACER	
812	1/8"	\$24
813	3/16"	\$24
811	pliers	\$14

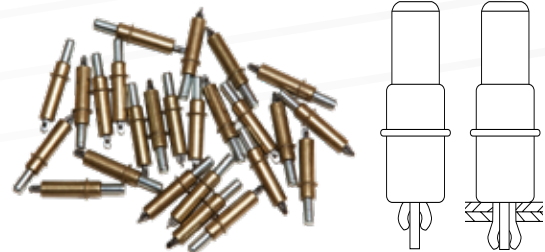

WINDOW INSTALLATION KIT

PERFECT MATCH FOR FIVE STAR'S PRE-CUT WINDOWS!

- Each kit includes enough hardware to install a windshield, rear window and quarter windows

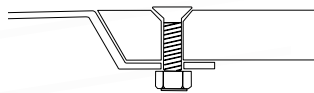
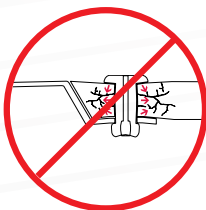

PART #	RACER	
805	8.2oz	\$16

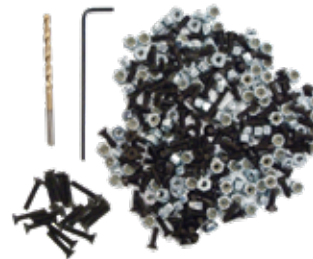

USING RIVETS TO INSTALL A WINDOW WILL FRACTURE POLYCARBONATE!

VISIT OUR WEBSITE FOR BODY MOUNTING GUIDELINES, TEMPLATES AND MORE!
*PRICES & PART NUMBERS SUBJECT TO CHANGE WITHOUT NOTICE.

BODY MOUNTING COMPONENTS

EVERYTHING YOU NEED TO MOUNT BODY PANELS!

ROOF LOCATING FIXTURE

MOUNT A COMPLETE BODY WITHOUT THE CHASSIS UNDERNEATH!

- ▶ This time-saving device makes locating the roof on your chassis a simple process
- ▶ Allows exact fit for wheel opening locations, body dimensions and inspection templates to fit series specs
- ▶ Black powder-coat finish
- ▶ Adjustable quarter panel arms
- ▶ Includes roof brackets & door height blocks
- ▶ Comes with assembly instructions

FIXTURE	Body Style	RACER
11002-72131	New Late Model Body	\$541
809P	Universal Short Track	\$541
REPLACEMENT ROOF BRACKETS		RACER
11002-72231	New Late Model Body	\$68
809-1P	ABC GEN1/Straight-up Fiberglass	\$69
809-2P	Straight-up Metal	\$64
809-3P	Fiberglass Sportsman	\$64
809-5P	Late Model Stock Car	\$69
809-6P	S2 Sportsman	\$64

*For replacement Roof Locating Fixture components & Door Blocks contact us!

THE FASTEST, EASIEST WAY TO MOUNT A BODY ON YOUR OWN!

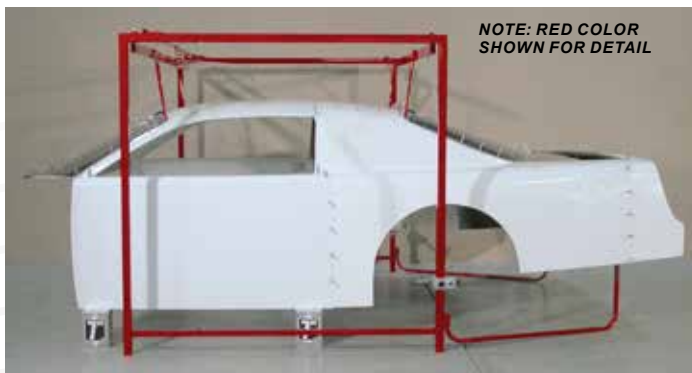

LIGHTWEIGHT REAR DECK MOUNTING KIT

EVERYTHING YOU NEED IN ONE CONVENIENT KIT!

DECK LID BRACKET:

SUPPORTS YOUR REAR BUMPER COVER!

- ▶ PN 660-450-DLB

DECK LID HEIGHT SLIDER:

ALLOWS FOR EASY ADJUSTMENT OF SPOILER HEIGHT!

- ▶ 3½" of deck lid height adjustability
- ▶ PN 802-3

DECK LID HOLD-DOWN KIT:

FOR EASY ACCESS TO YOUR FUEL CELL!

- ▶ PN 000-310H

PART #	DESCRIPTION	RACER
660-450-RDK	Rear Deck Mounting Kit	\$49

FITS THESE BODY STYLES: New Late Model Body, ABC, LMSC, S2, Straight-up Metal, Dirt Grand National

660-450-DLB



802-3



000-310H



Fully Installed 660-450-RDK

LIGHTWEIGHT ALUMINUM



DECK LID BRACKET

SUPPORTS YOUR REAR BUMPER COVER

EASY INSTALLATION RECOMMENDATIONS:

- Deck Lid Hold Down Kit PN 000-310H
- Telescoping Body Braces PN 860 & 860A
- Universal Bracing Kits: PN 807-1 or 807-2
- 1/4-20 Tap, left-hand or right-hand thread: PN 807LorR

PART #		RACER
11002-75633	aluminum	\$33

FITS THESE BODY STYLES: New Late Model Body, ABC, LMSC, S2, Straight-up Metal, Dirt Grand National



LIGHTWEIGHT STEEL

BODY MOUNTING TABS

USE FOR MOUNTING ROOF, COWL, DECK LID, SIDE BRACING AND MORE!

- (25) piece kit includes enough light weight weld-on tabs to install a complete body

PART #	RACER
807-4 (5oz)	\$19



LIGHTWEIGHT

INSTALLATION TUBING KIT

USE FOR BODY MOUNTING BRACING AND MORE!

- Bundle includes various shapes and sizes in 60" lengths
- (55) feet of hard to find, light weight tubing designed especially for racing!

PART #		RACER
819	55 feet, 60" lengths	\$37

#	Shape	Dia	Thickness
3	round	3/8"	.062"
2	round	1/2"	.062"
3	square	1/2"	.035"
3	square	3/4"	.049"



LIGHTWEIGHT ALUMINUM



DOOR SUPPORT

ALLOWS YOU TO EASILY ADJUST YOUR RIGHT SIDE DOOR TO THE PROPER WIDTH!

- Weighs under 2 lbs!



Fully Installed 11002-75533

PART #		RACER
11002-75533	aluminum	\$28

FITS THESE BODY STYLES: Late Model Body, ABC, S2, Truck, Fiberglass Sportsman, Dirt Grand National



VISIT OUR WEBSITE FOR BODY MOUNTING GUIDELINES, TEMPLATES AND MORE!
*PRICES & PART NUMBERS SUBJECT TO CHANGE WITHOUT NOTICE.

SUPPORT YOUR BODY PANELS WITH THESE GREAT UNIVERSAL BODY BRACING

LIGHTWEIGHT

HIGH-IMPACT MOLDED PLASTIC MD3 BODY BRACES

- These light weight high-impact plastic braces support body panels, and retain spring like flexibility when hit!
- Each brace weighs only 7oz!
- Constructed of the same high-quality plastic as our MD3 Noses
- 1¼" wide x 36" long x 0.30" thick - trim to fit your needs!

PART #		RACER
040-8000	Body Brace, black	\$8
040-8000-8	Body Brace, black, pkg of 8	\$43



LIGHTWEIGHT

POLYCARBONATE BODY BRACES

STIFF ENOUGH TO SUPPORT BODY PANELS, YET RETAINS SPRING-LIKE FLEXIBLY IF HIT!!

- Includes: (7) clear polycarbonate braces, 2½" x 27" each, (14) 1" x 2" aluminum mounting tabs
- Enough braces to complete one car!
- Complete set weighs less than 3 lbs!

PART #		RACER
804	Body Brace, polycarbonate	\$30

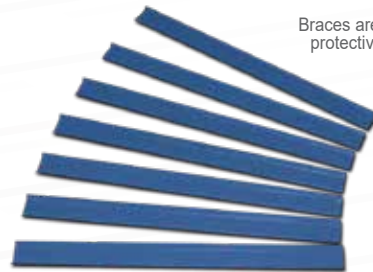

Braces are shown with protective masking.

LIGHTWEIGHT

ADJUSTABLE BODY BRACES

USE TO SUPPORT ROOF, DECK LID FILLER, QUARTER PANELS, SPOILER & MORE!

- Allows fine adjustments to panels to meet templates & critical dimensions
- Newly improved ends are shaped to allow ease of installation of rivets!
- Light weight, ultra-strong with anodized finish & cadmium hardware
- Adjustable: 8" to 10½"
- Package of 2 weighs only 1/2 lb!

PART #		RACER
807-3	pkg of 2	\$35



LIGHTWEIGHT ALUMINUM NOSE FLAP BRACES

62% LIGHTER THAN OTHER BRANDS, AND LESS THAN HALF THE PRICE!

- CNC-Laser Cut Aluminum
- Pre-drilled for riveting to nose and for mounting body bracing
- Both braces work great with Five Star's Telescoping Body Brace Kit (PN 860)
- Each pair weighs less than a pound!

LONG NOSE FLAP BRACES

- Mount to inside of wear strips with Five Star's Wear Strip Attaching Kit (PN 000-400K)

SHORT NOSE FLAP BRACES

- Mount vertically on nose flap

PART #		RACER
000-500	long, pair	\$39

FITS THESE BODY STYLES: ABC, LMSC, Short Track Truck, Fiberglass Sportsman, Straight-up Metal, Dirt Grand National

11002-75333	short, pair	\$13.50
-------------	-------------	---------

FITS THESE BODY STYLES: New Late Model Body, New Short Track Truck



000-500



11002-75333



LIGHTWEIGHT LOWER NOSE SUPPORT BRACKET



STRENGTHENS AND SUPPORTS LOWER VALANCE FOR OPTIMUM AERO

- Choose from a light weight aluminum or steel bracket
- 2-piece kit contains (2) brackets with (2) pre-welded on mounting tabs for ease of installation

PART #		RACER
11002-75733	aluminum	\$49
11002-75731	steel	\$44



11002-75733 ALUMINUM

LIGHTWEIGHT ALUMINUM QUARTER PANEL BODY BRACES



STIFFENS FLEXIBLE AREAS OF THE BODY TO MAXIMIZE AIRFLOW AROUND CAR!

- Five Star recommends bracing in this area of the body for tracks 1/2 mile and larger
- Pre-drilled holes in flanges in the necessary locations to mount braces from the chassis (approximately 6" back from wheel opening and 2" up from the bottom ledge)
- Pair weighs less than a pound!!

PART #		RACER
11002-75433	2-piece	\$39

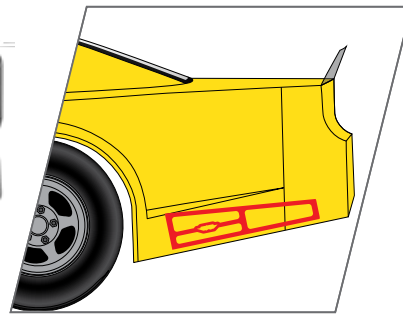

VISIT OUR WEBSITE FOR BODY MOUNTING GUIDELINES, TEMPLATES AND MORE!
 *PRICES & PART NUMBERS SUBJECT TO CHANGE WITHOUT NOTICE.

SUPPORT YOUR BODY PANELS WITH THESE GREAT UNIVERSAL BODY BRACING

LIGHTWEIGHT TELESCOPING BODY BRACE KITS

FULLY ADJUSTABLE UP TO 4" AND CAN BE USED ANYWHERE BRACING IS NEEDED!

STEEL KIT

- Made of high quality lightweight steel and weighs only 0.508 lbs!
- Kit includes: (6) tubes, (6) wing nuts, and (6) tabs
- or aluminum (0.194 lb)

ALUMINUM KIT

- Made of high quality lightweight aluminum and weighs only 0.194 lbs!
- Kit includes: (2) tubes, (2) wing nuts, and (2) tabs

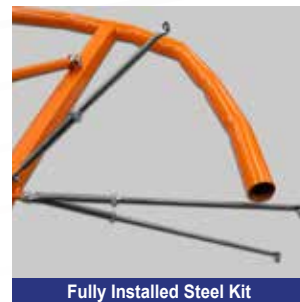

Fully Installed Steel Kit

PART #		RACER
860	steel, pkg of 6	\$61
860-A	aluminum, pkg of 2	\$29

LIGHTWEIGHT ALUMINUM WING NUT KIT

FOR USE WITH TELESCOPING BODY BRACES, AND IDEAL FOR ADJUSTING NOSE FLAPS IN FRONT OF THE TIRES!

- Kit includes: (6) wing nuts

PART #		RACER
860-W	wing nuts, pkg of 6	\$10



LIGHTWEIGHT ALUMINUM CUSTOM BRACING KIT

PREVENTS PRESSURE FLEXING!

- Light weight & strong
- Up to 2½" of adjustability
- Order as many tubing kits or end assemblies as needed to custom brace your car!
- Bolt on or hose clamp mount
- Complete Kit: (1) Tubing Kit; (1) End Assembly Kit; (1) Left and (1) Right Tap



PART #		RACER
807	Complete Kit	\$62
REPLACEMENT PARTS		RACER
807-1	Tubing Kit, 2-piece	\$19
807-2	End Assemblies, 6-piece	\$21
807LorR	Tap, left or right	\$11

ALUMINUM TUBING KIT

- (2) 7/16" x 3' holly hex rods that can be tapped easily
- Cut to desired length & tap



THREADED END ASSEMBLIES

- Shaped to allow ease of installation of rivets!
- (2) right, (2) left hand thread ends, and (2) hose clamps
- Kit weighs 7.5oz



1/4-20 TAP

- Extra-long shaft
- Re-usable



LIGHTWEIGHT ALUMINUM

WINDOW BRACES

SLOTTED SUPPORT FLANGE SAVES WEIGHT AND PROVIDES A CLEAN LOOK

- Designed to the exact contour of your windows and mounting hardware
- Made of premium high strength, ultra-strong light weight aluminum
- Weigh less than 2 lbs!
- Flat black powder-coat finish
- Foam-padded surface won't mar window
- Pre-drilled holes to mount adjustable bracing from the interior for added support to window
- Kit Includes: (3) CNC-machined aluminum braces



Windshield Braces Fully Installed



Rear Window Braces Fully Installed

PART #		RACER
NEW LATE MODEL BODY:		
11002-76333	front window	\$60
11002-76133	rear window	\$60
ABC/LMSC/STRAIGHT-UP METAL:		
564-6301	front window	\$85
674-6101	rear window	\$62
S2 SPORTSMAN:		
664-6301	front window	\$62
664-6101	rear window	\$62
ASPHALT MODIFIED:		
020-6301	front window	\$85
020-6101	rear window	\$62
SHORT TRACK TRUCK:		
21001-76333	front window	\$60



GREENHOUSE TO QUARTER PANEL BACK-UP PLATE KIT

REINFORCE THE SEAMS WHERE THE REAR GREENHOUSE MEETS THE QUARTER PANELS!

- Kits includes (2) pre-cut strips of light weight and durable high quality aluminum

PART #		RACER
000-27B	2-piece kit	\$7



FITS THE FOLLOWING BODY STYLES: New Late Model Body, ABC, LMSC, S2, Short Track Truck, Straight-Up metal, Dirt Grand National

FENDER TO NOSE BACK-UP PLATE KITS

REINFORCE THE FLANGE WHERE THE FENDERS MOUNT TO THE NOSE!

- Pre-drilled holes for easy installation!
- Made of light weight and durable high quality aluminum
- 4-piece kits include: (2) front and (2) rear plates (enough for both sides)

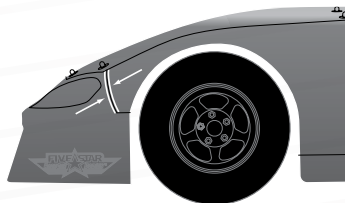

PART #		RACER
11002-75133	New Late Model Body	\$20
000-24B	Other Body Styles	\$21

FITS THESE BODY STYLES: New Late Model Body, ABC, LMSC, S2, Straight-up Metal, Dirt Grand National



11002-75133



000-24B

VISIT OUR WEBSITE FOR BODY MOUNTING GUIDELINES, TEMPLATES AND MORE!
*PRICES & PART NUMBERS SUBJECT TO CHANGE WITHOUT NOTICE.

ENHANCE YOUR BODY WITH THESE GREAT BODY ADD-ONS & ACCESSORIES

COWL INDUCTION

COLD AIR BOXES

FLOW BENCH TESTED FOR PEAK AIR FLOW

- Ultra light weight, strong and durable composite construction
- Maximum airflow using air filters as short as 3" without cfm loss
- Increased distributor and under hood clearance
- Fits a standard 14" filter element

4 BARREL AIR BOXES:

- Your choice of (2) angles to ensure a proper level fit on your engine
- These boxes feature a patented machined adapter ring for clean airflow, better fit and durability
- How to determine air box angle option:
 - Set car at proper ride height
 - Place angle finder on carburetor
- 3° Airbox is most commonly used for short track late models

2 BARREL OFFSET AIR BOX:

- Offset (2) barrel air box is for engines with a larger setback
- Designed to position the air filter farther forward for optimal flow without obstructing the cowl opening

PART #		RACER
000-5240	4 barrel, 0° angle (offset)	\$360
000-5243	4 barrel, 3° angle (standard)	\$360
000-5224	2 barrel, standard	\$300
000-5220	2 barrel, offset	\$300



PATENTED FLOW DESIGN

2 BBL AIR BOX DYNO TESTED!

"The results were outstanding! Five Star's latest 2bbl air box was 10HP & 16ft lbs of torque better than the old one!"

-Shane Harding, Harding Motorsports Chassis



Offset air box uses standard round filters

LIGHTWEIGHT COLD AIR BOX REFLECTIVE HEAT SHIELD KIT

REFLECTS AT LEAST 90% OF THE RADIANT HEAT FROM YOUR ENGINE, UP TO 500°F!

- Kit weighs less than 4oz!
- Light-duty reflective film with fiberglass backing for tear-resistance
- Self-adhesive backing: easy to apply and remove
- Cut to fit all air box styles!

PART #		RACER
000-52HS	Kit, 4oz	\$32



**LIGHTWEIGHT REFLECTIVE
HEAT SHIELD**

REFLECTS AT LEAST 90% OF THE RADIANT HEAT FROM YOUR ENGINE, UP TO 500°F!

- Sold as 27" x 5' lengths
- Weighs less than 3oz per linear foot!
- Light-duty reflective film with fiberglass backing for tear-resistance
- Self-adhesive backing: easy to apply and remove
- Extremely versatile, cut and form to fit your application!
 - Foot Boxes
 - Interiors
 - Fuel Filter Housings
 - Shock Canisters
 - Air Boxes
 - And more!!

PART #		RACER
000-5HS	5'x27" length	\$71

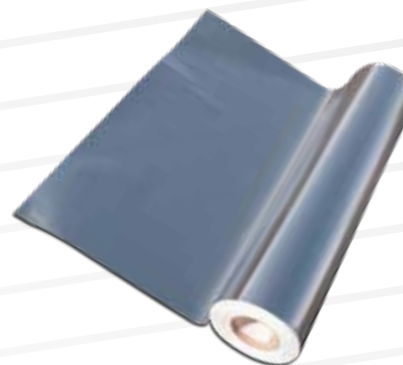

**COWL AIR DEFLECTOR
& AIR INLET INSERT**

- Cowl Air Deflector is made of black standard composite and connects the Cold Air Box to the Cowl
- Drop-in Cowl Air Inlet is adjustable for desired air flow, and is made of standard composite; available in (5) colors: -B -CB -R -W -Y

PART # (-X = COLOR)		RACER
000-5200A	Air Deflector, black	\$51
661-5100A-x	Cowl Air Insert	\$44



Cowl Air Deflector



Cowl Air Insert

**LIGHTWEIGHT ALUMINUM
COWL BRACKET TABS**

HOLDS HOOD FLAT ALONG WINDSHIELD COWL FOR A POSITIVE SEAL!

- Kit includes (4) CNC-machined aluminum pre-drilled tabs
- Fasten with screws or rivets and mount along flange of Windshield Cowl Panel
- Hood pins not included (use PN 803 or 803-A)

PART #		RACER
000-510	Cowl Bracket Tabs	\$13



FULLY MOUNTED

VISIT OUR WEBSITE FOR BODY MOUNTING GUIDELINES, TEMPLATES AND MORE!
*PRICES & PART NUMBERS SUBJECT TO CHANGE WITHOUT NOTICE.

ENHANCE YOUR BODY WITH THESE GREAT BODY ADD-ONS & ACCESSORIES

LIGHTWEIGHT WIDE ANGLE RACING MIRRORS

- ▶ EVERY MIRROR WEIGHS ONLY 14.3 OZ!
- ▶ OPTICALLY SUPERIOR LOW DISTORTION POLYCARBONATE
- ▶ Heavy-duty aluminum frame (17 $\frac{3}{4}$ " x 3")
- ▶ Included bracket kit makes for easy installation on any chassis!

SPLIT VIEW & CURVED MIRROR GIVE 95° OF RADIUS VISION, WITH ADDED SIDE VIEW, MORE THAN ANY OTHER RACING MIRROR!

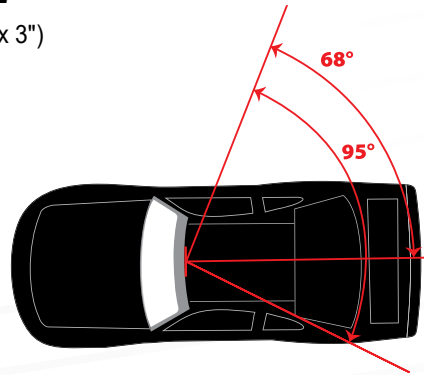

PART #		RACER
820-Split	Split View	\$86
820	Curved	\$86
820-Flat	Flat	\$86
820-B	Replacement Bracket	\$9

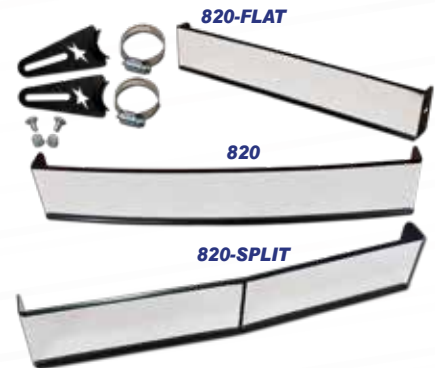

LIGHTWEIGHT POLYCARBONATE RUB RAIL

PROTECT YOUR VINYL, WITHOUT HIDING IT!

- ▶ Save your graphics!!
- ▶ Attach with rivets to side of body to eliminate tire marks on fenders, doors and quarter panels
- ▶ 75" long, you trim to fit

PART #		RACER
000-2100	75" long	\$21 ea



LIGHTWEIGHT MOLDED PLASTIC
BRAKE DUCT KITS

DESIGNED TO FIT NOSE AT CORRECT ANGLE!

- Choice of (2) styles; single or double
- Universal fit for all noses; fits either side
- Single duct can use 3" or 4" tubing;
Double duct uses 3" tubing
- Crimped 3/16" stainless steel screen keeps debris out
- Each kit includes pre-cut stainless steel screen, rivets and washers

PART #		RACER
000-412D	Single	\$28
000-411D	Double	\$28

FITS THESE BODY STYLES: New Late Model Body (Single Only) ABC, LMSC, S2, Short Track Truck, Fiberglass Sportsman, Straight-up Metal, Street Stock

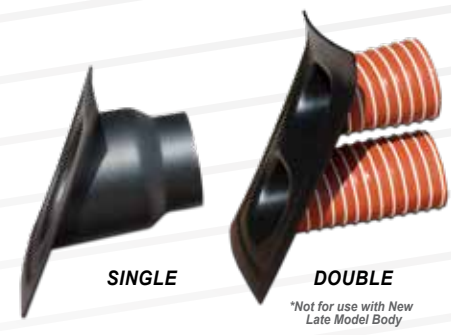

**Not for use with New Late Model Body*

BRAKE COOLING HOSES

- Choice of Standard Temperature (Neoprene) Hose or High Temperature (Silicon) Hose in both 3" and 4" diameters



Standard Temperature (Neoprene) Hose



High Temperature (Silicon) Hose

PART #	MATERIAL	TEMP	DIA.	LENGTH	RACER
000-325ST	Neoprene	350° F	3"	10'	\$70
000-325HT	Silicon	600° F	3"	11'	\$114
000-425ST	Neoprene	350° F	4"	10'	\$85
000-425HT	Silicon	600° F	4"	11'	\$135

LIGHTWEIGHT
POLYCARBONATE
DOOR VENT
WINDOWS

FOR THE ULTIMATE IN AERODYNAMICS!

- Wind tunnel proven performance gain!
- Oversized and Cut-to-fit options made of molded, mar-resistant coated polycarbonate
- **EACH WINDOW WEIGHS UNDER A POUND!**



FULLY INSTALLED 11002-66222



FULLY INSTALLED 000-6202

New Late Model Body Door Vent Window is pre-cut-to-fit for fast and easy installation!

PART #		RACER
000-6202	oversized, set of 2	\$28
11002-66222	cut-to-fit, set of 2	\$28

FITS THESE BODY STYLES: Late Model Body, ABC, LMSC, S2, Fiberglass Sportsman, Straight-up Metal, Street Stock, Asphalt Modified

VISIT OUR WEBSITE FOR BODY MOUNTING GUIDELINES, TEMPLATES AND MORE!
 *PRICES & PART NUMBERS SUBJECT TO CHANGE WITHOUT NOTICE.

ENHANCE YOUR BODY WITH THESE GREAT BODY ADD-ONS & ACCESSORIES

LIGHTWEIGHT MOLDED PLASTIC RADIATOR DUCTS

INCREASE FRONT DOWNFORCE!

- Molded from Five Star's exclusive, ultra-durable plastic blend!
- Efficient cooling allows for smaller radiator air intake opening, resulting in increased front downforce!
- Access panel for easy debris clean-out
- 100% positive seal to grill screen opening

000-408:

- 6-piece design is easy to install and fits to any radiator offset, width and angle!
- Includes molded plastic radiator mounting flange and Nose Air Inlet Extension
- Kit weighs less than 13lbs!

11002-42151 (NEW LATE MODEL BODY):

- 5-piece design is easy to install and fits to any radiator offset
- Includes molded plastic radiator mounting flange
(the Nose Air Inlet Extensions is not needed for the New Late Model Body)

PART #		RACER
000-408	short track bodies	\$179
11002-42151	new late model body	\$147

FITS THESE BODY STYLES: New Late Model, ABC, LMSC, S2, Straight-up Metal, Street Stock

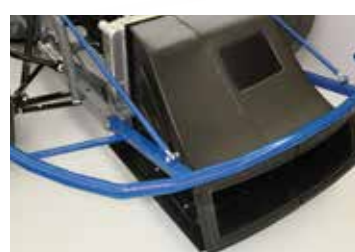

000-408 FULLY INSTALLED



11002-42151 FULLY INSTALLED

BUMP 'N RUN FLEXIBLE RADIATOR DUCTS

➤ SAVE YOUR RADIATOR!

- Retains 100% functionality even after a hit!
- Efficient air flow cools radiator
- Size by Radiator Core (not Cooling Tank)
- All include molded plastic radiator mounting flange
- Nose Air Inlet Extension for 000-409 Radiator Ducts only

STREET STOCK

- Flexible Radiator Duct replaces rigid metal ductwork with a custom canvas bag and aluminum or plastic framing
- Fits Howe and other radiators with similar core dimensions



ABC/S2	RACER	STYLE/SIZE	NEW LATE MODEL	RACER
000-409-1	\$137	Griffin, 22 $\frac{3}{8}$ " x 17 $\frac{1}{8}$ "	11002-42120	\$109
000-409-2	\$137	Howe, 24 $\frac{1}{4}$ " x 18 $\frac{1}{2}$ "	11002-42121	\$109
000-409-3	\$137	Howe, 22 $\frac{1}{4}$ " x 18 $\frac{3}{4}$ "	11002-42122	\$109
000-409-4	\$137	C & R, 22 $\frac{1}{4}$ " x 17 $\frac{3}{4}$ "	11002-42123	\$109
000-409-5	\$137	C & R, 24 $\frac{1}{4}$ " x 17 $\frac{3}{4}$ "	11002-42124	\$109
000-409-6	\$137	Howe, 27 $\frac{1}{4}$ " x 18 $\frac{1}{2}$ "	11002-42125	\$109
LMSC	RACER	STYLE/SIZE	STREET STOCK	RACER
672-409-6	\$137	Howe, 27 $\frac{1}{4}$ " x 18 $\frac{1}{2}$ "	600-409-6	\$126
N/A	N/A	Howe, 24 $\frac{1}{4}$ " x 18 $\frac{1}{2}$ "	600-409-2	\$126



FULLY INSTALLED 000-409



STREET STOCK 600-409

LIGHTWEIGHT MOLDED PLASTIC
NOSE AIR INLET
EXTENSION

INCREASE RIGIDITY OF THE NOSE!

- ▶ Molded Plastic construction and weighs less than 2 lbs!
- ▶ Ideal for racers who build their own aluminum radiator box
- ▶ Included with both the 000-408 Molded Plastic and Flexible Radiator Duct

PART #		RACER
000-409-NP	Air Inlet Extension	\$29

FITS THESE BODY STYLES: ABC, LMSC, S2, Truck, Straight-up Metal, Street Stock



LIGHTWEIGHT
HIGH-IMPACT PLASTIC
WEAR STRIPS

PROTECT THE LOWER EDGE OF YOUR NOSE IN STYLE!

- ▶ Helps to seal the nose to the track to optimize aerodynamics
- ▶ CNC machined from Five Star's exclusive blend of ultra-durable plastic
- ▶ 2-piece kit is ready to install with Five Star's Wear Strip Attaching Kit
- ▶ Available in (10) colors!



PART #		RACER
11002-41551-x	New Late Model Body	\$30
000-400-x	ABC, LMSC, Straight-up Metal, Dirt Grand Nat'l	\$30
664-400-x	S2	\$38
600-400-x	Classic Street Stock (n/a in Fluorescent colors)	\$41
021-400-x	MD3 Street Stock	\$30



11002-41551 INSTALLED ON NEW LATE MODEL BODY NOSE



000-400 INSTALLED ON LMSC BODY NOSE

LIGHTWEIGHT ALUMINUM
WEAR STRIP
ATTACH KITS

ALL THE HARDWARE YOU NEED TO INSTALL WEAR STRIPS!

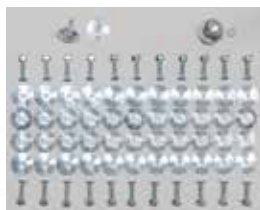

- ▶ Each kit includes light weight aluminum machined washers

PART #		RACER
000-400K	25 sets (full installation)	\$57
000-400K10	10 sets (replace (1) wear strip)	\$27

VISIT OUR WEBSITE FOR BODY MOUNTING GUIDELINES, TEMPLATES AND MORE!
*PRICES & PART NUMBERS SUBJECT TO CHANGE WITHOUT NOTICE.

ENHANCE YOUR BODY WITH THESE GREAT BODY ADD-ONS & ACCESSORIES

LIGHTWEIGHT ALUMINUM & STEEL HOOD PIN BRACKETS

PREFORMED TO FIT THE TOP OF THE NOSE TO MEET TEMPLATES!

- ▶ Aluminum option weighs less than 2 lbs (less than half the weight of steel)
- ▶ Aluminum option newly updated to include mounting tabs at each end for ease of installation!
- ▶ Includes (5) tabs for (5) hood pins
- ▶ Will work for both 1/2" & 3/8" hood pins

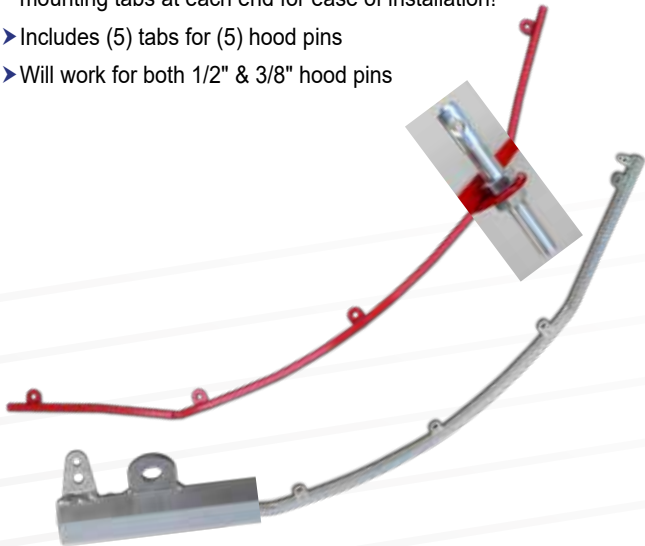

PART #		RACER
NEW LATE MODEL BODY:		
11002-34333	3/4" OD, aluminum (common)	\$64
11002-34331	3/4" OD, steel (common)	\$31
ABC/LMSC/STRAIGHT-UP:		
660-411A-HPB	3/4" OD, aluminum (excludes Ford)	\$63
570-411A-HPB	3/4" OD, aluminum (Ford)	\$63
660-411-HPB	3/4" OD, steel (excludes Ford)	\$31
570-411-HPB	3/4" OD, steel (Ford)	\$31
660-410-HPB	1/2" OD, steel (excludes Ford)	\$28
570-410-HPB	1/2" OD, steel (Ford)	\$28
S2:		
664-411-HPB	3/4" OD, steel	\$31
664-410-HPB	1/2" OD, steel	\$28
SHORT TRACK TRUCK:		
T230-410-HPB	1/2" OD, steel (Chevrolet)	\$28
T250-410-HPB	1/2" OD, steel (Ford)	\$28
21001-34131	1/2" OD, steel, common	\$28
STREET STOCK:		
600-410-HPB	3/4" OD, steel ('88 Monte Carlo)	\$31
DIRT GRAND NAT'L:		
700-410-HPB	1/2" OD, steel (excludes Ford)	\$28
703-410-HPB	1/2" OD, steel (Ford)	\$26
FIBERGLASS SPORTSMAN:		
634-410-HPB	1/2" OD, steel (Monte Carlo)	\$28
334-410-HPB	1/2" OD, steel (Grand Prix)	\$26

LIGHTWEIGHT ALUMINUM HOOD PIN KITS

- ▶ Flip-over style prevents clips from falling out
- ▶ 1/2" Kit includes: (5) aluminum pins, (5) aluminum scuff plates, (5) flip-over steel clips, (10) jam nuts
- ▶ 3/8" Kit includes: (5) newly improved gun-drilled aluminum pins (half the weight of standard), (5) aluminum scuff plates, (5) flip-over steel clips, (10) jam nuts

PART #		RACER
803-A	3/8" pin kit	\$33
803	1/2" pin kit	\$33
803-PS	1/2" Scuff Plate, aluminum	\$2
803-PA3/8	3/8" Scuff Plate, aluminum	\$2



803 1/2" Hood Pin Kit



803-A 3/8" Hood Pin Kit

LIGHTWEIGHT ALUMINUM HOOD PROP

PERFECT WHEN USED WITH A PAIR OF HOOD HINGES!

- ▶ Made of durable and strong machined light weight heavy duty aluminum!
- ▶ Sold as a pair, (2) needed for hood installation

PART #		RACER
000-3400	pair	\$64

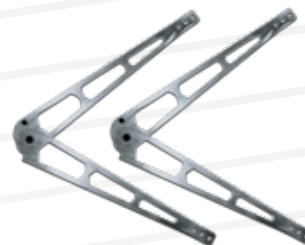

LIGHTWEIGHT ALUMINUM HOOD HINGE KITS

DESIGNED FOR EASY INSTALLATION ON ALL FIVE STAR BODIES!

- ▶ Two options available, each fabricated from high quality aluminum stock

SHORT HINGE

- ▶ (2) Hinge Kits are required to complete the installation of a hood
- ▶ Kit includes, hinge, pin and clip assembly

LONG HINGE

- ▶ (1) Kit is required to complete the installation of a hood
- ▶ Kit includes hinge, pin and clip assembly

PART #		RACER
000-33H	short, aluminum	\$16
11002-73333	long, aluminum	\$39
000-33HP	replacement pin & clip	\$2.20



ALL NEW

FULLY INSTALLED 11002-73333



FULLY INSTALLED 000-33H

VISIT OUR WEBSITE FOR BODY MOUNTING GUIDELINES, TEMPLATES AND MORE!
*PRICES & PART NUMBERS SUBJECT TO CHANGE WITHOUT NOTICE.

ENHANCE YOUR BODY WITH THESE GREAT BODY ADD-ONS & ACCESSORIES

FORMED STEEL FRONT BUMPERS

EXACTLY CONTOURED TO THE INSIDES OF OUR PLASTIC NOSES FOR MAXIMUM PROTECTION!

- ▶ Formed from 1 3/4" round steel tubing with a finished appearance
- ▶ Install your bumper with Five Star's Front Bumper Mounting Kit

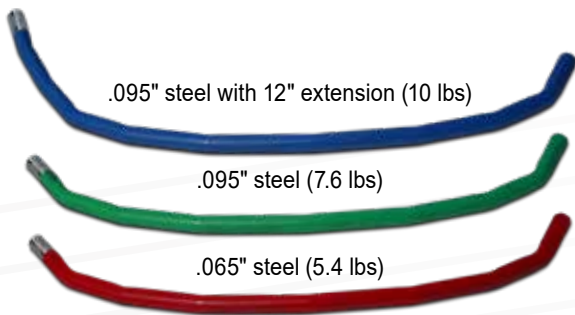

PART #		RACER
NEW LATE MODEL BODY:		
11002-71182	.065" steel	\$33
11002-71185	.095" steel	\$33
11002-71188	.095" steel (12" extended right side)	\$42
ABC/LMSC/STRAIGHT-UP:		
660-7103	.065" steel	\$33
660-7103B	.095" steel	\$33
660-7103C	.095" steel (12" extended right side)	\$41
S2:		
664-7103	.065" steel	\$33
664-7103B	.095" steel	\$33
SHORT TRACK TRUCK:		
T250-7103 (Ford)	.065" steel	\$33
T230-7103B (Chevrolet)	.065" steel	\$33
21001-71162 (Common)	.065" steel	\$33
STREET STOCK:		
600-7103 ('88 Monte Carlo)	.065" steel	\$33
600-7103B ('88 Monte Carlo)	.095" steel	\$33
DIRT GRAND NAT'L:		
700-7103	.065" steel	\$33
700-7103B	.095" steel	\$33
FIBERGLASS SPORTSMAN:		
634-7103 (Monte Carlo)	.065" steel	\$33
334-7103 (Grand Prix)	.065" steel	\$33

FRONT BUMPER MOUNTING KIT

EVERYTHING YOU NEED TO EASILY INSTALL YOUR BUMPER!

- ▶ Allows for precise adjustments to nose height

COMPLETE KIT:

- ▶ Kit includes: (2) 3' sections of 3/4" round tubing; (4) clevis, eye bolts & nuts; (2) 1 1/2" square pieces of square tubing; (2) pieces of flat stock; 1/2" nuts & bolts, mounting tabs, and a pivoting chassis mount

REPLACEMENT KIT:

- ▶ Kit includes: (2) 1 1/2" square pieces of square tubing; (2) pieces of flat stock; 1/2" nuts & bolts and mounting tabs

PART #		RACER
802-5	Complete Kit	\$62
802-4	Replacement Kit	\$42

FITS THESE BODY STYLES: New Late Model Body, ABC, LMSC, S2, Short Track Truck, Fiberglass Sportsman, Straight-up Metal, Street Stock, Dirt Grand National

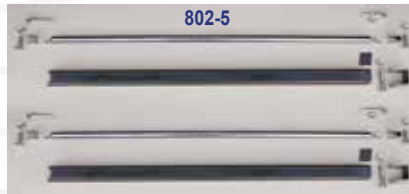

FORMED STEEL REAR BUMPERS

EXACTLY CONTOURED TO THE INSIDES OF OUR PLASTIC BUMPER COVER FOR MAXIMUM PROTECTION!

- Formed from 1 3/4" round .065" steel tubing with a finished appearance
- Weighs less than 8lbs!
- Install your bumper with Five Star's Rear Bumper Mounting Kit

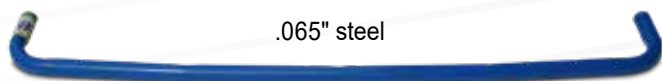

PART #		RACER
NEW LATE MODEL BODY:		
11002-71682	.065" steel	\$33
ABC/LMSC/STRAIGHT-UP/S2/DIRT GRAND NAT'L:		
570-7503	.065" steel	\$33
SHORT TRACK TRUCK:		
T00-7503 (Ford & Chevrolet)	.065" steel	\$33
STREET STOCK:		
600-7501 ('88 Monte Carlo)	.065" steel	\$33
FIBERGLASS SPORTSMAN:		
630-7503 (Monte Carlo)	.065" steel	\$33

REAR BUMPER MOUNTING KITS

EASY WAYS TO MOUNT YOUR REAR BUMPER!

HEIGHT-ADJUSTABLE KIT:

- Allows for several different mounting options
- Pivots to allow precise adjustments to the height of the rear bumper cover
- Kit includes: (2) clevis, eye bolts & nuts; a 36" long 1 1/2" square piece of tubing; (2) pieces of flat stock; and (2) 1/2" nuts & bolts

NON-ADJUSTABLE KIT:

- Contains everything you need to mount your rear bumper or make it a bolt-on component!
- Kit includes: (2) 3' long 1 3/4" thick pieces of round tubing, (2) pieces of .120" thick square tubing and 5/16" hex bolts and nuts

PART #		RACER
802-2S	height-adjustable	\$20
802-2	non-adjustable	\$19

FITS THESE BODY STYLES: New Late Model Body, ABC, LMSC, S2, Short Track Truck, Fiberglass Sportsman, Straight-up Metal, Dirt Grand Nat'l



Rear Bumper Fully Installed

VISIT OUR WEBSITE FOR BODY MOUNTING GUIDELINES, TEMPLATES AND MORE!
*PRICES & PART NUMBERS SUBJECT TO CHANGE WITHOUT NOTICE.

ENHANCE YOUR BODY WITH THESE FIVE STAR RECOMMENDED CHEMICALS

FIVE STAR WINDOW CLEANER

WITH ANTI-FOG PROTECTANT

MAXIMIZES OPTICAL CLARITY FOR THE MOST EXTREME CONDITIONS!

- ▶ Five Star Window Cleaner is specially formulated to be the ultimate product for cleaning and protecting all clear plastics!
- ▶ Also works great on glass!
- ▶ Repels finger smudges, dirt, dust, grime and moisture with a streak and haze-free finish!
- ▶ This high performance cleaner contains a special anti-fog agent that prevents fogging!
- ▶ Available in 24oz and 8oz spray bottles



PART #		RACER
843	24oz bottle	\$8.95
843-8	8oz bottle	\$6.95

DRIVEN RACING OIL SPEED SHIELD

SPRAY & SHINE PROTECTANT

- ▶ Shine your unpainted plastic body panels and components!
- ▶ Formulated to repel dirt, dust and mud while providing a glossy protective finish!
- ▶ Works well on aluminum and on the under-body of your car to keep mud from sticking!

PART #		RACER
00001-84172	12oz can	\$8.99



FIVE STAR PLASTIC PRIMER

PROMOTES PAINT ADHESION TO ALL FIVE STAR PLASTIC COMPONENTS

- Using any other primer will result in flaking or peeling! This is specially formulated for the plastic used in our parts, so before you paint be sure it's Five Star Primer!
- (2) cans = (2) coats on: nose, bumper cover, both fenders, both quarter panels, both rocker panels

PART #		RACER
842	11.3oz can	\$17

FIVE STAR QUICK TIP »

IF YOU ARE GOING TO PAINT YOUR PLASTIC PANELS, YOU MUST USE FIVE STAR PLASTIC PRIMER & NO OTHER!

- There are plenty of primers on the market but the plastic used in our parts is not the same plastic as used elsewhere in the automotive industry.

USING ANY OTHER PRIMER WILL RESULT IN SEVERE PAINT FLAKING!

- So before you paint, be sure you have your Five Star Primer, follow the directions on the can precisely & say goodbye to any paint adhesion problems.



HEAR FROM TOP TEAMS AND WHY THEY CHOOSE FIVE STAR!



Bill Venturini, ARCA Racing Series: Driver- Dalton Sargeant

"We've been using the Five Star composite bodies and we really really like them!! When we are building these cars the composite body makes our job installing them easy! Within 2-3 hours of fabricating you can bolt the body onto the chassis and you are ready to go racing!"



Casey Smith, Southern Super Series Driver

"The main reason I changed to a Five Star Body is the quality and the quick response. When I need something, I know for sure it's going be right!"



Donnie Wilson, Southern Super Series Driver

"The reason I switched to Five Star Bodies is obviously because of the quality and fit of the bodies, and it's NUMBER ONE IN OUR SPORT!"



Nick Egan, Short Track Truck Driver

"Egan Motorsports chooses Five Star Bodies because of their high quality fit and durability. Easy to assemble in the shop, easy to hang new panels mid-season, and always the best looking cars and trucks around."



Alex Crapser, Dirt Street Stock Driver

"Five Star steel street stock bodies are the best appearing 1980s Monte Carlo body. Being able to buy ready to go individual panels saves us a lot of time during the offseason. Every piece fits with the rest of the Five Star pieces, saving a valuable time trying to match up pieces off a car from a junkyard. There is no rust to deal with which saves time fabricating patches. Along with the awesome steel panels, the plastic nose and rear bumper cover are made to take a beating, a necessity in street stock racing."



Robbie Scott, Rocket Chassis: Driver - Josh Richards

"The #1 reason we choose Five Star's MD3 body panels on our Rocket XR1's over all the rest is their unsurpassed durability. Their Rigid Design keeps us ahead of the competition by keeping us in the Race!"



Jeff Burton, Team Owner: Driver - Harrison Burton

"We now buy Five Star Bodies because we like the consistency, we know when parts come in they're going to weigh the same as the part before, one's not heavier than the other one, they all fit the same and that makes the installation so much easier and it saves time!"



Robby Gordon, Stadium Super Truck Series Owner & Driver

"The reason we choose Five Star is for the quality, reliability and consistency and these guys are the best in the business I've seen!"



FIVESTARBODIES.com/BETTERBODIES
NOBODY ELSE CAN OFFER MORE!



TERMS & CONDITIONS / SHIPPING

Five Star Race Car Bodies & Components are available throughout North America from our nationwide dealer network. To locate your nearest dealer visit www.FIVESTARBODIES.COM. If there is no dealer in your area, purchases can be made directly from Five Star. If you have any questions, please call us!

TERMS & CONDITIONS

DEALER DIRECT ORDERS: We encourage all customers to buy from our stocking dealers. If the dealer in your area knows the body style you are running, he will stock the items you need. Also, through our dealer incentives, many times he can SAVE you money on shipping charges. Call for the dealer nearest you.

FACTORY ORDERS: Most orders are shipped the same day they are placed. Our telephone hours are 8:00 am to 5:00 pm Central time, Monday through Friday, evenings and weekends by chance. A \$20.⁰⁰ packaging fee will be charged on motor freight orders under \$150.⁰⁰.

SHIPPING: All orders are shipped FCA Five Star Fabricating, Twin Lakes, Wisconsin freight collect. All truck freight orders must be pre-paid with credit card, cashier's check, money order, bank wire or certified check. UPS orders may be pre-paid with VISA, Mastercard, Discover, AMEX or can be shipped COD/cash.

RETURNS: Unused parts may be returned provided the items are in new, undamaged condition (no dents, scrapes, holes drilled, rust, etc.). Returned items must be packaged with care and shipped freight pre-paid to Five Star Fabricating, Inc., 36728 89th Street, Twin Lakes, WI 53181. A 20% re-stocking charge applies on all returns. No returns on special order items.

WARRANTY: Due to the intended use of these products in racing, Five Star Fabricating, Inc. makes no statement of warranty or guarantee, written or oral, expressed or implied. Once the part is installed, the purchaser must assume all responsibility arising from malfunction, damage or misuse. No employee or officer of Five Star Fabricating, Inc. or its distributors has any authority to make statements contrary to these terms and conditions.

PAYMENT OPTIONS

PAYMENT BY CREDIT CARD: Five Star Fabricating, Inc. accepts VISA, MasterCard, Discover and American Express. Your credit card will be billed for the full amount of the order upon receipt and will ship immediately. All orders shipped other than UPS Ground Services must be pre-paid in this manner.



PAYMENT BY CASHIER'S CHECK/MONEY ORDER: Five Star Fabricating, Inc. accepts Cashier's Checks and Money Orders from any US-based bank. Your order will ship immediately following our receipt of your payment. We do not accept personal or company checks under any circumstances.

UPS SHIPPING

Most component and accessory orders can be shipped via UPS. These items include (but are not limited to) noses, bumper covers, aluminum & steel doors, spoilers, formed steel bumpers, installation kits and rivets.

UPS SHIPPING CONT.

UPS GROUND: Shipments sent via UPS Ground will deliver before the end of the business day by a time pre-determined by your zip code. This varies from one to five business days. Please contact our Customer Service Department for actual UPS shipping time.

UPS NEXT DAY AIR: Shipments sent via UPS Next Day Air will deliver before the end of the next business day following shipment.

UPS NEXT DAY AIR SATURDAY DELIVERY: Shipments sent via UPS Next Day Air Saturday Delivery will deliver by 3:30 pm (ET) Saturday.

UPS SECOND DAY: Shipments sent via UPS Second Day will deliver before the end of the second business day following shipment.

UPS THREE DAY SELECT: Shipments sent via UPS Three Day Select will deliver before the end of the third business day following shipment.

AIR SHIPPING

Five Star Fabricating, Inc. uses dimensional shipping weight on all air shipments which many times varies from actual component weight. Due to the extreme costs associated with shipping items by air, we encourage you to plan accordingly when ordering components for your car. Please contact our Customer Service Department with inquiries regarding your special shipping requirements.

TRUCK SHIPPING

Orders too large, too heavy or requiring shipment in three or more boxes must be shipped via truck freight. These parts include (but are not limited to) complete bodies, hoods, roofs, quarter panels and some fenders.

All truck orders must be shipped to a commercial address. Residential deliveries will incur a minimum \$45.00 surcharge. Residential address implies that there is a home on the property which is, therefore, not zoned as a business.

Truck shipping times vary with delivery location and carrier. Due to the expense of truck shipping, it is imperative that you plan accordingly when purchasing components for your car.

NOTE: Five Star Fabricating, Inc. uses actual shipping weight on all truck shipments which many times varies from actual component weight. Please contact our Customer Service Department for inquiries regarding truck shipments.

NOTE: PRICING SUBJECT TO CHANGE WITHOUT NOTICE.

LEARN MORE ABOUT FIVE STAR'S STATE-OF-THE-ART FACILITIES



FIVE STAR RACE CAR BODIES

Corporate Headquarters located in Twin Lakes, WI

- 200,000+ sq. ft. of clean, modern work space, efficient manufacturing, computer & robotic controls overseen by skilled American craftsman



DEALER WAREHOUSE & DISTRIBUTION CENTER

Located in Troutman, NC

- Since our customer base increased in the southeast portion of the United States, Five Star proudly opened a Dealer Service Center based in Troutman, North Carolina.
- All orders and order pick ups must be scheduled through Five Star's Corporate Headquarters in Twin Lakes, WI.



FIVE STAR COATINGS GROUP

Located in Twin Lakes, WI

- A revolutionary company leading the way in the world of custom coated plastic products. Our facility boasts the most advanced technology available, bringing you the highest quality coatings for the toughest applications.
- As a leading edge supplier of abrasion resistant and specialty coatings, Five Star Coatings Group is the clear choice for your business. We guarantee the highest level of optical properties found in the industry today.



SUSTAINABILITY: GREEN & SAFE

Five Star Race Car Bodies and Five Star Coatings Group are committed to environmental excellence through the implementation of environmental protection, product stewardship and regulatory compliance programs.

VISIT OUR WEBSITE FOR BODY MOUNTING GUIDELINES, TEMPLATES AND MORE!

*PRICES & PART NUMBERS SUBJECT TO CHANGE WITHOUT NOTICE.

FIVE STAR Bodies™

RaceCar

www.FIVESTARODIES.com

THE ONLY FULL BODY & WINDOW SOURCE FOR ALL FORMS OF RACING!



»» GO FAST WITH FIVE STAR THE BETTER BODY CHOICE!

»» FAST DELIVERY

GET YOUR FIVE STAR PRODUCTS FASTER

- » Thousands of parts in stock in 2 warehouse locations
- » Same day shipping
- » 200+ dealers nationwide
- » Famous first-class customer service

»» FAST INSTALLATION

INSTALL A COMPLETE FIVE STAR BODY IN WAY LESS TIME THAN OTHER BODIES

- » The absolute tightest weight tolerances
- » Shape consistency and flawless finishes
- » Replacement panels that fit exactly the same, every time
- » Full line of accessories for a true professional look

»» FAST TO THE FINISH LINE

UNSURPASSED IMPACT RESISTANCE & DURABILITY

- » Minimal bracing required - more rigid at high speeds
- » Body panels absorb more impact
- » Less breakage = less debris on the race track
and less time in the pits

NOBODY ELSE CAN OFFER MORE! »»





ADVANCED BODY TECHNOLOGY

PRODUCTS AT THE FOREFRONT OF

QUALITY & PERFORMANCE

FROM GRASS ROOTS TO PROFESSIONAL RACING...  HAS YOU COVERED!

FIVESTARBODIES.com |    | 262.877.2171

ISO 9001:2015
QUALITY
CERTIFIED



PO BOX 700
TWIN LAKES, WI 53181

To locate your nearest Five Star Dealer
visit www.FIVESTARBODIES.com
© find a **FIVE STAR DEALER**



OUR FAMILY OF FIVE STAR BRANDS



FIVE STAR RACE CAR BODIES

A DIVISION OF FIVE STAR FABRICATING, INC.

PO BOX 700 | 36728 89TH ST | TWIN LAKES, WI

PH.: (262) 877-2171 FAX: (262) 877-3702



FIVESTARBODIES.COM | FIVESTARBODIES