



Performance Cooling Products

*Fluid Coolers | Fluid Filtration | Transmission Cooling Pans
Electric Fans | Electric Fan Controllers | Belt Driven Fans | Fuel Pumps*

DERALE
PERFORMANCE
A US Motor Works Brand

**THE LEADER IN
PERFORMANCE COOLING**



US Motor Works, LLC and its employees are committed to providing an extensive line of consistent High Quality Products and the finest Customer Service and Satisfaction, through our Quality Management System based on ISO 9001:2015

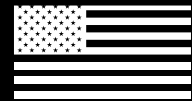

Powered By



Derale PERFORMANCE

Since 1975

Derale Performance
 US Motor Works Performance Division
 3901 Medford St.
 Los Angeles, Ca 90063
 Ph: (323) 266-3850
 Fax: (323) 263-3948

DERALE.COM

While most cooling brands focus on one component of the vehicle, Derale aims to cool the drivetrain as a whole. Whether you drive a truck, race the tracks or crawl through the desert, your drivetrain is designed to function as a unit. The most powerful engine is only as strong as its ability to transfer that power to the wheels. Our approach to cooling is the same, cool as a unit. By controlling all major components of a vehicle, engine, transmission, power steering, fuel and differential you drastically increase efficiency and component life.

Manufactures of...

Direct Fit Cooling Kits.....	4-5	Hose & Install Kits.....	45
Remote Fluid Coolers	6-16	Fluid Filtration Kits	46-55
Hi-flow Racing Remote Fluid Coolers	6-7	Engine Oil Filter Relocation Kits.....	46-47
Hyper-Cool Remote Fluid Coolers	8-9	Remote Filter Mount Kits.....	48-49
Atomic-Cool Remote Fluid Coolers.....	10-11	Engine Oil Filter Adapter Kits.....	50-52
Electra-Cool Remote Fluid Coolers.....	12-13	LS Engine Adapters	53
Econo-Cool Remote Fluid Coolers	14	Filtration Kits.....	54
Dyno-Cool Remote Fluid Coolers.....	15	Fittings and Accessories	55
Plate & Fin Fluid Cooler	16	Transmission Cooling Pans.....	56-59
Fluid Control Thermostats.....	16	Electric Fans	60-73
Inline Fan Control.....	17	Single Rad Fan Aluminum Powerpacks	60-61
Remote Fluid Coolers - Quick Guide.....	18	Dual Rad Fan Aluminum Powerpacks.....	62-64
Ram Air Fluid Coolers	19-39	Single/Dual Rad Fan Molded Powerpacks.....	65
Series 9500 Plate & Fin Fluid Coolers.....	19	High Output Electric Fans.....	66-69
Series 10000 Stack Plate Fluid Coolers.....	20-23	Dyno-Cool Electric Fans	70
Series 9000 Plate & Fin Fluid Coolers.....	24-25	Electric Fan Accessories	71
Series 8000 Plate & Fin Fluid Coolers.....	26-27	Electric Fans - Quick Guide	72-73
Series 7000 Tube & Fin Fluid Coolers.....	28-32	Electric Fan Controllers.....	74-76
Series 6000 Dyno-Cool Tube & Fin Fluid Coolers...33		PWM Electric Fan Controllers.....	74
Heat Sink Fluid Coolers.....	34-36	High Amp Controllers	75
Radiator Cooling Fittings.....	37	Adjustable Controllers	76
Ram Air Coolers - Quick Guide.....	38-39	Mechanical Controller	76
		Single Stage Controllers	76
		Performance Fuel Pumps	77
		Belt Driven Fans and Fan Spacers.....	78-81
		Index.....	82-83

Recommend for...

Engine • Transmission • Power Steering
 Fuel and Differential





THE LEADER IN PERFORMANCE COOLING

DIRECT FIT COOLING KITS

Ford Full Size Truck & SUV Engine Oil Cooler Kit

Application: 1999-2005 Ford F-150, F-250, F-350,
Excursion & Expedition, 4.6, 5.4, 6.0 & 7.3L

- Drastically reduce engine oil temperatures
- Cooler mounts in lower air dam

Features:

- Series 10000 25 row stack plate cooler
- Black powder coated aluminum brackets
- OEM spec hose with 300 P.S.I. burst rating
- All necessary hardware included for a fast, easy, bolt-on installation

Part No.	BTU
20543	32000

Mustang GT 5.0 Engine Oil Cooler Kit

Application: 2011-2014 Ford Mustang GT 5.0

- Drastically reduce engine oil temperatures
- Cooler mounts in lower air dam

Features:

- Series 10000 16 row stack plate cooler
- Clear anodized aluminum brackets
- Black AN braided hose
- All necessary hardware included for a fast, easy, bolt-on installation

Part No.	BTU
20542	32000

Mustang GT 5.0 Transmission Cooler Kit

Application: 2011-2014 Ford Mustang GT 5.0

- Prevents heat-related component failure and fluid breakdown
- Cooler mounts in lower air dam

Features:

- Series 10000 16 row stack plate cooler
- Clear anodized aluminum brackets
- Black AN braided hose
- All necessary hardware included for a fast, easy, bolt-on installation

Part No.	BTU
20541	32000



NEW





JEEP JK Power Steering Cooler Kit

Application: 2007-2018 Jeep JK (All Models)

Features:

- Sturdy all aluminum heat Sink cooler design
- Black anodized finish
- Neatly mounts behind grille
- All necessary hardware included for a fast, easy, bolt-on installation

Part No.	BTU
20565	2300



JEEP YJ/TJ Performance Electric Fan

Application: 1987-1996 Jeep Wrangler YJ - (4 & 6 Cyl)
1997-2006 Jeep Wrangler TJ - (4 & 6 Cyl)

Features:

- 16" High Output fan shroud assembly replaces factory fan clutch/shroud using factory mounting locations
- Radiator reservoir remount brackets included (use on some 4 & 6 cyl. applications)
- Power steering remount brackets included (use on some 4 cyl. applications)
- Kit includes 180°F thermostat switch to activate electric fan

Replacement 190°F Temp Sensor and Fitting: Part# 35030

Part No.	Repl. Fan Part No.	CFM	Amp Draw
20161	16136	2400	23.5



JEEP YJ/TJ Automatic Transmission Cooler

Application: 1987-1996 Jeep Wrangler YJ - (4 & 6 Cyl)
1997-2006 Jeep Wrangler TJ - (4 & 6 Cyl)

Features:

- Mounts to frame rail with no drilling
- Powerful 8" electric fan
- Efficient 16 row Plate & Fin cooler
- Reduces fluid temperatures 30°F - 40°F

Part No.	Repl. Cooler Part No.	Frame Mount Bracket Set	BTU	CFM	Amp Draw
20561	13750	20500	22000	500	4.8

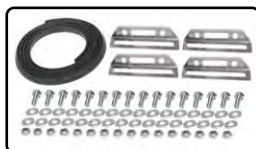

JEEP Cherokee Performance Electric Fan

Application: 1987-2000 Jeep Cherokee

- Fits OE and aftermarket radiators
- Bolts directly to stock radiator mounts
- Three 9" IP68 Water Proof/Dust Proof high-output electric fans
- Fan controllers offered on pg. 74-76



Part No.	Repl. Fan	CFM*	Amp Draw	Dim A. (Width)	Dim B. (Height)	Dim C. (Depth)	Dim D. (Overall Depth)	Dim E.	Dim F.	Dim G.	Dim H.
NEW 16839	16110	2400	27.6	31-1/2"	10-1/4"	1 1/8"	3-1/4"	23-3/4"	28"	7-3/4"	9-1/2"



THE LEADER IN PERFORMANCE COOLING

Hi-Flow Racing Remote Fluid Coolers



Features and Benefits

Derale is proud to introduce our latest addition to the remote cooler lineup. These Hi-Flow Racing Coolers are precision TIG welded and feature the most efficient tube design in the aftermarket, which supports up to 350 PSI with minimal pressure drop. All electric fans are IP68 certified (Water/Dust Proof) and designed to do their best under the most strenuous conditions. These coolers are perfect for everything from Drag racing to Off-Road.

- **Aircraft aluminum grade cooler design**
- **Extruded tube design with turbulators for maximum heat dissipation**
- **Precision TIG welding**
- **20 GPM Flow rate**
- **Supports up to 350 P.S.I., with minimal pressure drop**

Dimensions

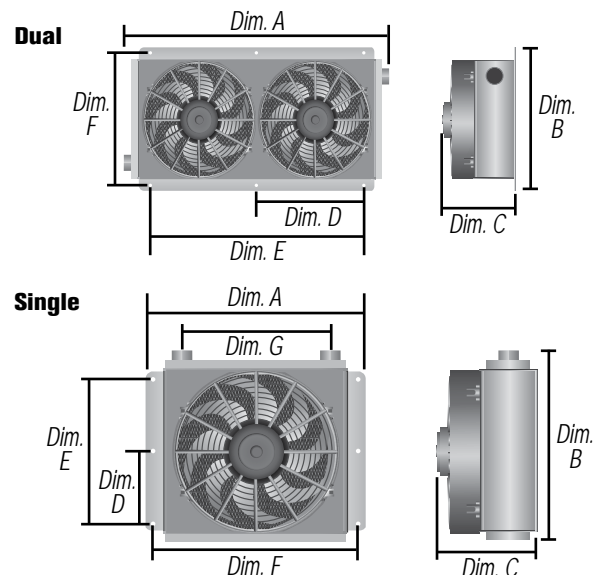



Hi-Flow 11 Row Racing Cooler

- Designed for Puller applications
- 630 CFM Combined, (2) 5" IP68 Electric Fans
- Black Anodized Shroud
- 7/8-14 UNF O-Ring inlets

Recommended for:

Engines
 Transmissions
 Power Steering
 Fuel and Differentials



Thermostat switches and aluminum fittings sold separately, see page 17, 40

Cooler Part No.	Inlet Size	Repl. Core	Repl. Fan	Fan CFM	Fluid Capacity	BTU	Dim. A (Width)	Dim. B (Height)	Dim. C (Depth)	Dim. D (Mounting)	Dim. E (Mounting)	Dim. F (Mounting)
65840	7/8-14o-ring	61178	16105	630	33 oz.	95000	15"	8 1/4"	7"	5 1/2"	11"	7 3/16"



Hi-Flow 18 Row Racing Cooler

- Designed for Puller applications
- 755 CFM, 9" IP68 Electric Fan
- Black Anodized Shroud
- 7/8-14 UNF O-Ring inlets

Recommended for:

Engines
 Transmissions
 Power Steering
 Fuel and Differentials



Thermostat switches and aluminum fittings sold separately, see page 17, 40

Cooler Part No.	Inlet Size	Repl. Core	Repl. Fan	Fan CFM	Fluid Capacity	BTU	Dim. A (Width)	Dim. B (Height)	Dim. C (Depth)	Dim. D (Mounting)	Dim. E (Mounting)	Dim. F (Mounting)	Dim. G (Inlet)
65861	7/8-14 o-ring	61878	16119	755	47 oz.	125000	11 7/8"	12 3/8"	8 1/2"	3 3/8"	6 3/4"	11"	7"



Hi-Flow 18 Row Racing Cooler

- Designed for Puller applications
- 625 CFM, 9" IP68 Electric Fan
- Black Anodized Shroud
- 7/8-14 UNF O-Ring inlets

Recommended for:

Engines
 Transmissions
 Power Steering
 Fuel and Differentials



Thermostat switches and aluminum fittings sold separately, see page 17, 40

Cooler Part No.	Inlet Size	Repl. Core	Repl. Fan	Fan CFM	Fluid Capacity	BTU	Dim. A (Width)	Dim. B (Height)	Dim. C (Depth)	Dim. D (Mounting)	Dim. E (Mounting)	Dim. F (Mounting)	Dim. G (Inlet)
65860	7/8-14 o-ring	61878	16109	625	47 oz.	125000	11 7/8"	12 3/8"	6 5/8"	3 3/8"	6 3/4"	11"	7"



THE LEADER IN PERFORMANCE COOLING

Hyper-Cool Remote Fluid Coolers



Features and Benefits

- Powerful high output electric fans
- Ultra efficient Series 10000 stack plate coolers
- Sturdy furnace-brazed aluminum construction tested to 250 PSI
- Aluminum shroud/mounting assembly
- Mounts anywhere space permits
- Clear anodized shrouds
- All coolers feature 7/8-14 UNF O-Ring inlets

Dimensions

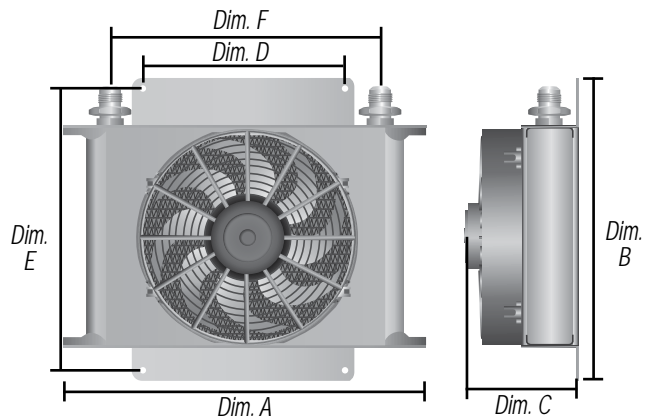

Thermostat switches and hardware available individually. See page 17



Recommended for:
Engines
Transmissions



Hyper-Cool Extreme

- Series 10000 40-row stack plate cooler
- 800 CFM, 10" electric fan
- Designed for Puller applications
- Cooler kit includes oil cooler and two aluminum AN fittings

Cooler Kit Part No.	Inlet Size	Repl. Core	Repl. Fan	Fluid Capacity	BTU	Dim. A (Width)	Dim. B (Height)	Dim. C (Depth)	Dim. D (Mounting)	Dim. E (Mounting)	Dim. F (Inlets)
13870	-6 AN	54078	16110	26 oz	67000	13"	14 7/8"	5 5/8"	7 1/2"	13 9/16	10"
15870	-8 AN	54078	16110	26 oz	67000	13"	14 7/8"	5 5/8"	7 1/2"	13 9/16	10"
15875	-10 AN	54078	16110	26 oz	67000	13"	14 7/8"	5 5/8"	7 1/2"	13 9/16	10"
15876	-12 AN	54078	16110	26 oz	67000	13"	14 7/8"	5 5/8"	7 1/2"	13 9/16	10"



Recommended for:
Engines
Transmissions
Power Steering
Fuel and Differentials

Hyper-Cool

- Series 10000 25-row stack plate cooler
- 500 CFM, 8" electric fan
- Designed for Puller applications
- Cooler kit includes oil cooler, two aluminum AN fittings and two hose barb fittings

Transmission cooler kit



Install Kit Only Part # 13022 - 3/8" Hose
13023 - 1/2" Hose

Engine oil cooler kit



Install Kit Only Part # 15752

Cooler Kit Part No.	Weatherproof IP68 Fan Part No.	Cooler Inlet Size	Trans Cooler Kit Part No.	Engine Oil Cooler Kit Part No.	Repl. Core	Repl. Fan	Fluid Capacity	BTU	Dim. A (Width)	Dim. B (Height)	Dim. C (Depth)	Dim. D (Mounting)	Dim. E (Mounting)	Dim. F (Inlets)
13760	-----	-6 AN	13960	-----	52578	16618	16 oz	46000	13"	10"	5 5/8"	7 1/2"	9"	10"
15860	-----	-8 AN	15960	15660	52578	16618	16 oz	46000	13"	10"	5 5/8"	7 1/2"	9"	10"
15865	-----	-10 AN	-----	-----	52578	16618	16 oz	46000	13"	10"	5 5/8"	7 1/2"	9"	10"
-----	13764	7/8-14 o-ring	-----	-----	52578	16108	16 oz	46000	13"	10"	5 1/4"	7 1/2"	9"	10"



Recommended for:
Engine
Transmission
Power Steering
Fuel and Differential



Hyper-Cool Dual

- Series 10000 Highly efficient 19-row stack plate cooler
- 630 CFM (combined), (2) 5" electric fans
- Designed for Puller applications
- Cooler kit includes oil cooler and two aluminum AN fittings

Cooler Kit Part No.	Inlet Size	Repl. Core	Repl. Fan	Fluid Capacity	BTU	Dim. A (Width)	Dim. B (Height)	Dim. C (Depth)	Dim. D (Mounting)	Dim. E (Mounting)	Dim. F (Inlets)
13740	-6 AN	51978	16105	12 oz	37000	13"	7 3/8"	4 7/8"	7 1/2"	7"	10"
15840	-8 AN	51978	16105	12 oz	37000	13"	7 7/16"	4 7/8"	7 1/2"	7"	10"
15845	-10 AN	51978	16105	12 oz	37000	13"	7 9/16"	4 7/8"	7 1/2"	7"	10"



THE LEADER IN PERFORMANCE COOLING

Atomic-Cool Remote Fluid Coolers

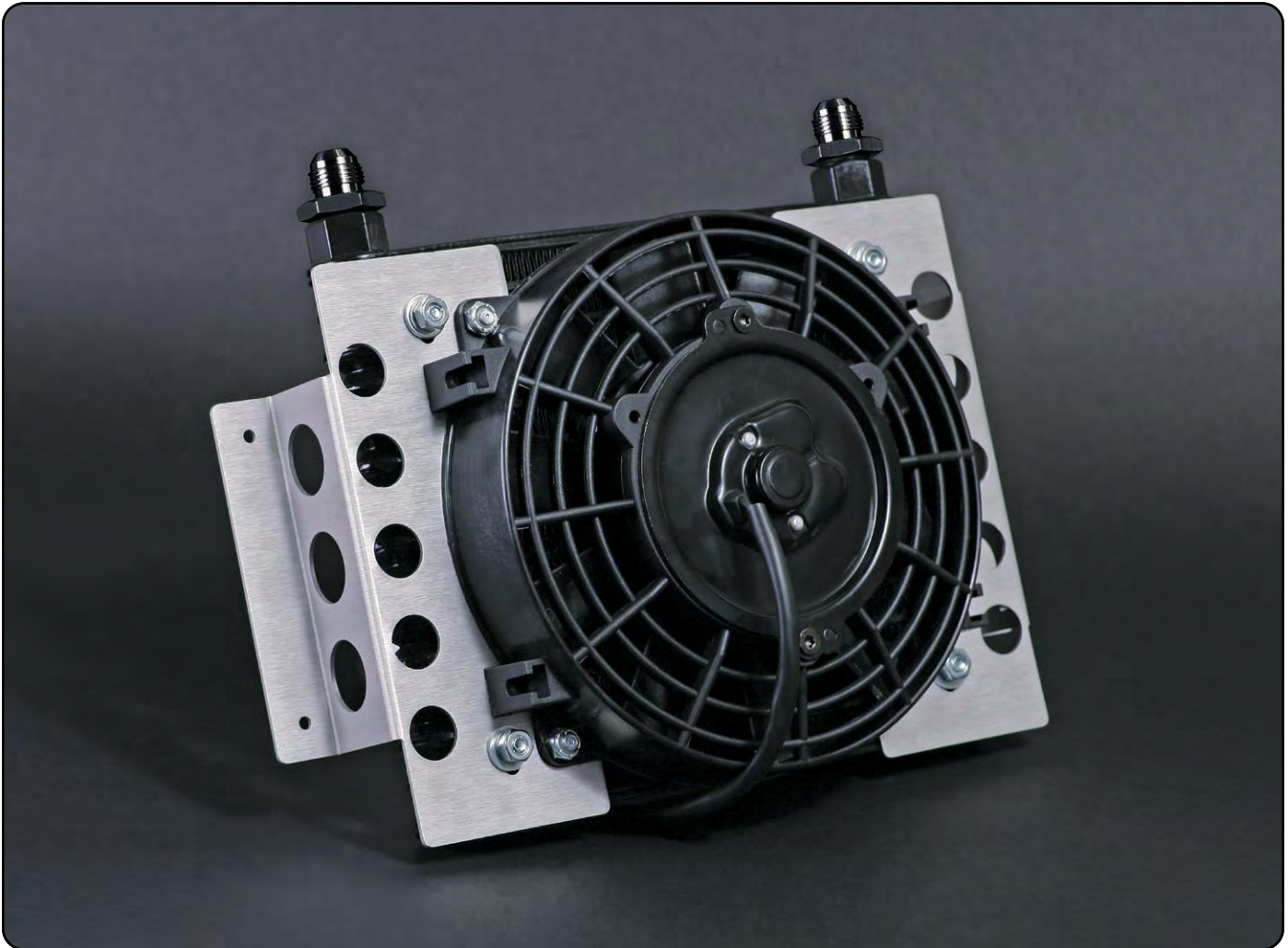

Features and Benefits

- Powerful high output electric fans
- Efficient Series 9000 16 row Plate & Fin coolers
- Sturdy furnace-brazed aluminum construction
- Mounts anywhere space permits
- Clear anodized shrouds
- All coolers feature 5/8-18 UNF O-Ring fittings

Dimensions

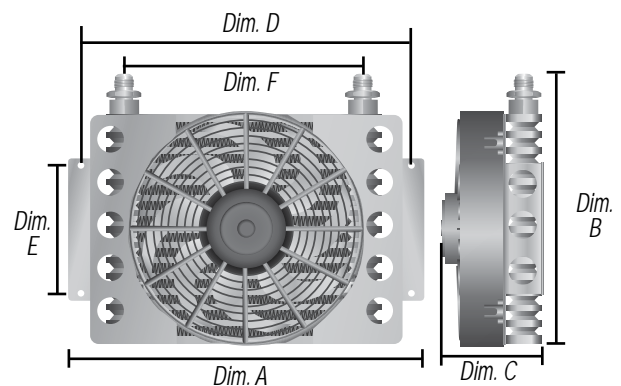

Thermostat switches and hardware available individually, see page 17



Recommended for:
 Engine
 Transmission
 Power Steering
 Fuel and Differential

Atomic-Cool Fluid Cooler

- Series 9000 16-row Plate & Fin cooler
- 500 CFM, 8" Electric fan
- Designed for Puller applications
- Cooler assembly includes oil cooler, two black anodized aluminum AN and hose barb adapter fittings



Cooler Kit Part No.	Weatherproof IP68 Fan Part No.	Inlet Size	Repl. Core	Repl. Fan	Fluid Capacity	BTU	Dim. A (Width)	Dim. B (Height)	Dim. C (Depth)	Dim. D (Mounting)	Dim. E (Mounting)	Dim. F (Inlets)
13750	-----	-6 AN	13751	16618	17 oz	22000	12 3/4"	9 3/8"	4 5/16"	11 5/8"	4"	8 9/16"
15850	-----	-8 AN	15851	16618	17 oz	22000	12 3/4"	9 3/8"	4 5/16"	11 5/8"	4"	8 9/16"
-----	13754	-6 & -8 AN	15851	16108	17 oz	22000	12 3/4"	9 3/8"	3 15/16"	11 5/8"	4"	8 9/16"



Atomic-Cool Transmission Cooler Kits

- Extends transmission service life by preventing heat-related component failure & fluid breakdown
- Hardware kit includes in-line fan control, high-pressure/high temperature hose & mounting hardware

Install Kit Only Part # 13022 - 3/8" Hose
 13023 - 1/2" Hose



Trans Cooler Kit Part No.	Inlet Size	Repl. Core	Repl. Fan	Fluid Capacity	BTU	Dim. A (Width)	Dim. B (Height)	Dim. C (Depth)	Dim. D (Mounting)	Dim. E (Mounting)	Dim. F (Inlets)
13950	-6 AN	13751	16618	17 oz	22000	12 3/4"	9 3/8"	4 5/16"	11 5/8"	4"	8 9/16"
15950	-8 AN	15851	16618	17 oz	22000	12 3/4"	9 3/8"	4 5/16"	11 5/8"	4"	8 9/16"



Atomic-Cool Engine Oil Cooler Kit

- Helps reduce engine oil temperature
- Extends engine life
- Hardware kit includes in-line fan control, sandwich adapter, hose barb adapters, high-pressure/high temperature hose & mounting hardware

Install Kit Only Part # 15752



Engine Oil Cooler Kit Part No.	Inlet Size	Repl. Core	Repl. Fan	Fluid Capacity	BTU	Dim. A (Width)	Dim. B (Height)	Dim. C (Depth)	Dim. D (Mounting)	Dim. E (Mounting)	Dim. F (Inlets)
15450	-8 AN	15851	16618	17 oz	22000	12 3/4"	9 3/8"	4 5/16"	11 5/8"	4"	8 9/16"



THE LEADER IN PERFORMANCE COOLING

Electra-Cool Remote Fluid Coolers

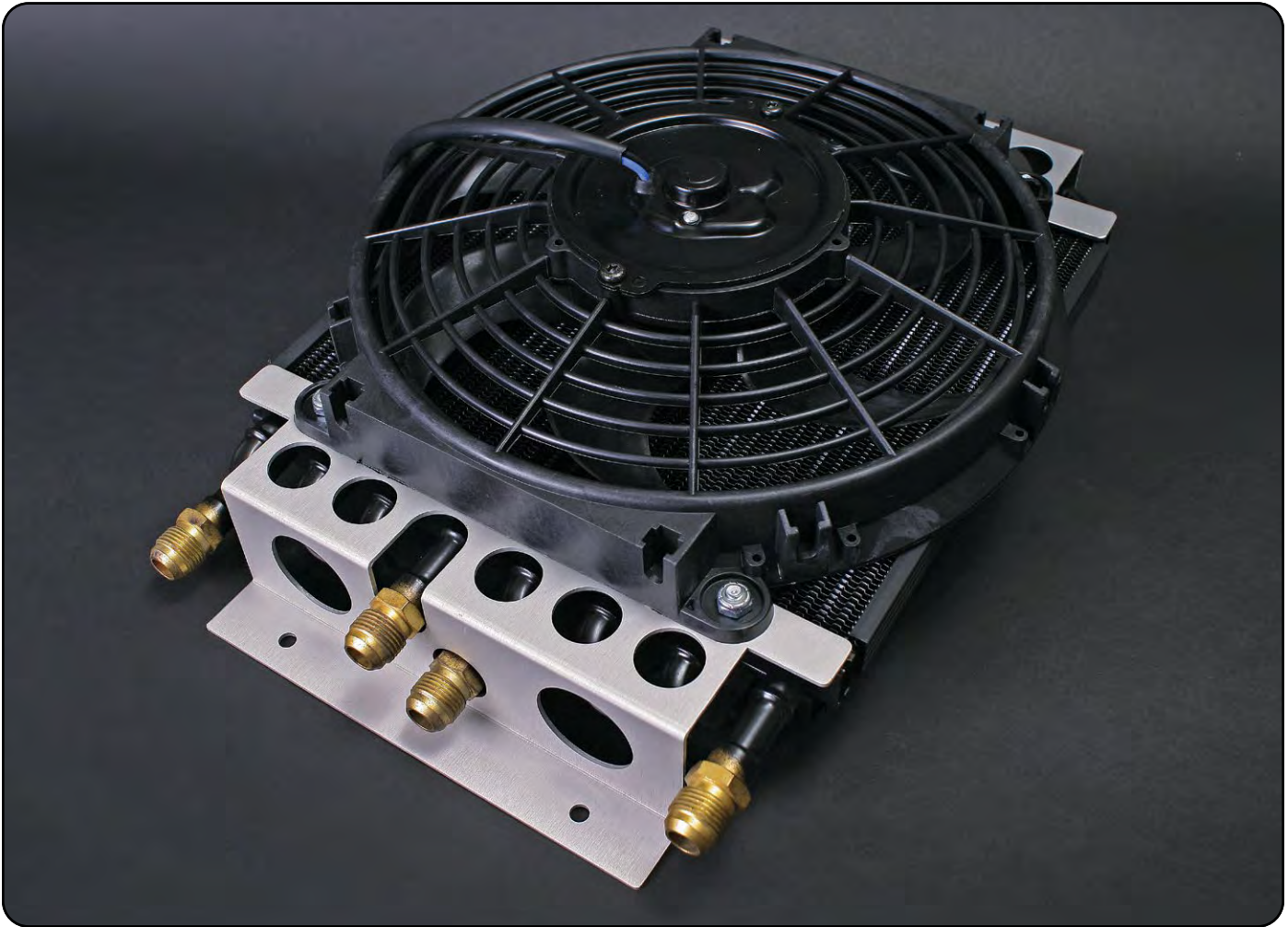

Features and Benefits

- Powerful high output electric fans
- Efficient Series 7000 Tube & Fin coolers
- Copper/Aluminum construction
- Mounts anywhere space permits
- Clear anodized mounting brackets
- All coolers feature AN inlets

Dimensions

Single Circuit

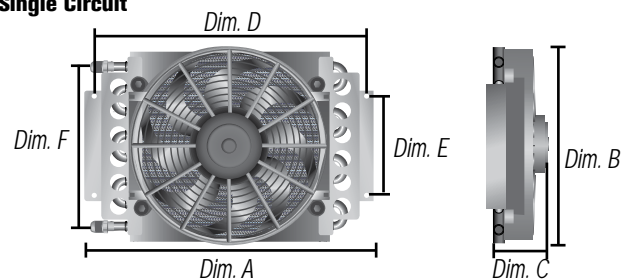

Dual Circuit

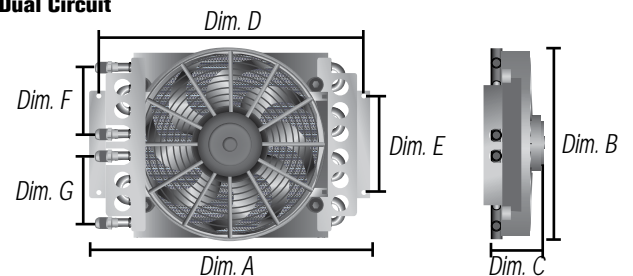

Thermostat switches available individually, see page 17



Electra-Cool Fluid Cooler Single & Dual Circuit

Recommended for:
Engine
Transmission
Power Steering
Fuel and Differential

- Series 7000 Tube & Fin cooler
- 650 cfm, Powerful 10" electric fan
- Designed for Puller applications
- Aluminum AN hose barb adapter fittings included



Cooler Kit Part No.	No. of Passes	Inlet Size	Repl. Core	Repl. Fan	Fluid Capacity	BTU	Dim. A (Width)	Dim. B (Height)	Dim. C (Depth)	Dim. D (Mounting)	Dim. E (Mounting)	Dim. F (Inlet to Inlet)	Dim. G (Inlet to Inlet)
13700	16	-6 AN	13300	16620	19 oz.	14000	15 3/4"	11 1/2"	5"	14 3/4"	5 1/4"	8 3/4"	--
15800	16	-8 AN	15300	16620	19 oz.	14000	15 3/4"	11 1/2"	5"	14 3/4"	5 1/4"	8 3/4"	--
13720	8	-6 AN	13320	16620	9 oz.	7000	15 3/4"	11 1/2"	4"	14 3/4"	5 1/4"	8 3/4"	--
15820	8	-8 AN	15320	16620	9 oz.	7000	15 3/4"	11 1/2"	4"	14 3/4"	5 1/4"	8 3/4"	--
Dual Circuit													
15200	8 & 8 pass	-8 AN	15301	16620	9 oz.	16000	15 3/4"	11 1/2"	5"	14 3/4"	5 1/4"	4 1/8"	4 1/8"
15220	4 & 4 pass	-8 AN	15321	16620	4.5 oz.	8000	15 3/4"	11 1/2"	4"	14 3/4"	5 1/4"	3 3/4"	3 3/4"



Electra-Cool Transmission Cooler Kits

- Extends transmission service life by preventing heat related component failure & fluid breakdown
- Hardware kit includes in-line fan control, high-pressure/high temperature hose and mounting hardware

Install Kit Only Part # 13022 - 3/8" Hose
 13023 - 1/2" Hose



Trans Cooler Kit Part No.	No. of Passes	Inlet Size	Repl. Core	Repl. Fan	Fluid Capacity	BTU	Dim. A (Width)	Dim. B (Height)	Dim. C (Depth)	Dim. D (Mounting)	Dim. E (Mounting)	Dim. F (Inlet to Inlet)	Dim. G (Inlet to Inlet)
13900	16	-6 AN	13300	16620	19 oz.	14000	15 3/4"	11 1/2"	5"	14 3/4"	5 1/4"	8 3/4"	--
15900	16	-8 AN	15300	16620	19 oz.	14000	15 3/4"	11 1/2"	5"	14 3/4"	5 1/4"	8 3/4"	--



Electra-Cool Engine Oil Cooler Kit

- Helps reduce coolant temperature
- Extends engine life
- Hardware kit includes in-line fan control, sandwich adapter, hose barb adapters, high-pressure/high temperature hose and mounting hardware

Install Kit Only Part # 15752



Engine Oil Cooler Kit Part No.	No. of Passes	Inlet Size	Repl. Core	Repl. Fan	Fluid Capacity	BTU	Dim. A (Width)	Dim. B (Height)	Dim. C (Depth)	Dim. D (Mounting)	Dim. E (Mounting)	Dim. F (Inlet to Inlet)	Dim. G (Inlet to Inlet)
15500	16	-8 AN	15300	16620	19 oz.	14000	15 3/4"	11 1/2"	5"	14 3/4"	5 1/4"	8 3/4"	--



THE LEADER IN PERFORMANCE COOLING

Econo-Cool Remote Fluid Coolers

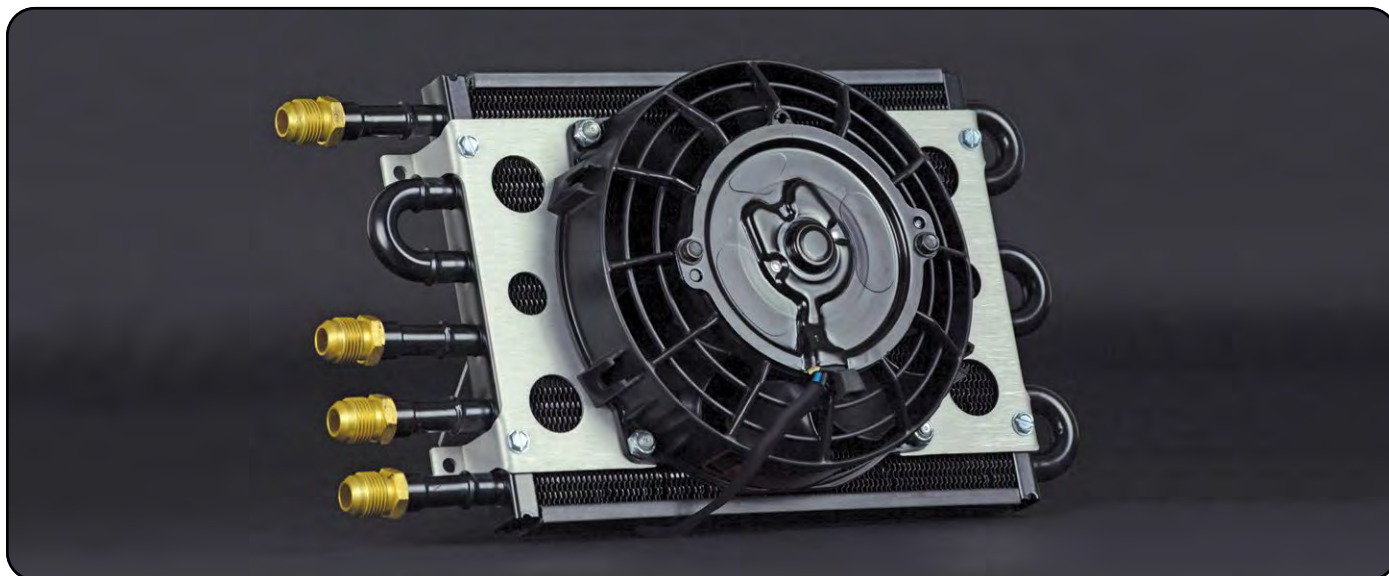

Econo-Cool Single Circuit

- Efficient 6 pass copper/aluminum tube and fin cooler
- 400 CFM, reversible 8" electric fan
- Clear anodized aluminum bracket

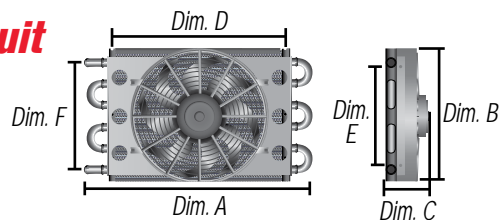

Recommended for:
Engine **Power Steering**
Transmission **Fuel and Differential**

Cooler Part No.	No. of Passes	Inlet Size	Repl. Core	Repl. Fan	Fluid Capacity	BTU	Dim. A (Width)	Dim. B (Height)	Dim. C (Depth)	Dim. D (Mounting)	Dim. E (Mounting)	Dim. F (Inlet to Inlet)
13730	6	11/32" Barb	13731	16618	4 oz.	6000	12 3/4"	7 5/8"	3 3/4"	10 7/8"	5"	6 1/4"
15830	6	1/2" Barb	15831	16618	4 oz.	6000	12 3/4"	7 5/8"	3 3/4"	10 7/8"	5"	6 1/4"



Econo-Cool Dual Circuit

- Efficient 4 pass & 2 pass copper/aluminum tube and fin cooler
- 400 CFM, reversible 8" electric fan
- -8 AN fittings with hose barb fittings included
- Clear anodized aluminum bracket

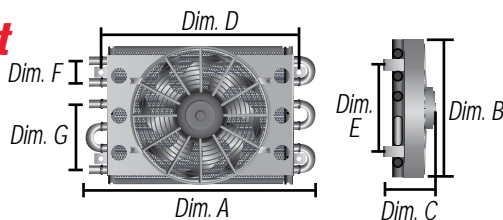

Recommended for:
Engine **Power Steering**
Transmission **Fuel and Differential**

Cooler Part No.	No. of Passes	Inlet Size	Repl. Core	Repl. Fan	Fluid Capacity	BTU	Dim. A (Width)	Dim. B (Height)	Dim. C (Depth)	Dim. D (Mounting)	Dim. E (Mounting)	Dim. F (Inlet to Inlet)	Dim. G (Inlet to Inlet)
15230	4 & 2	-8 AN	15331	16618	4 oz. & 2.25 oz	6000	13 15/16"	7 5/8"	3 3/4"	10 7/8"	5"	3 3/4"	1 1/4"

Dyno-Cool Remote Fluid Coolers



THE LEADER IN PERFORMANCE COOLING

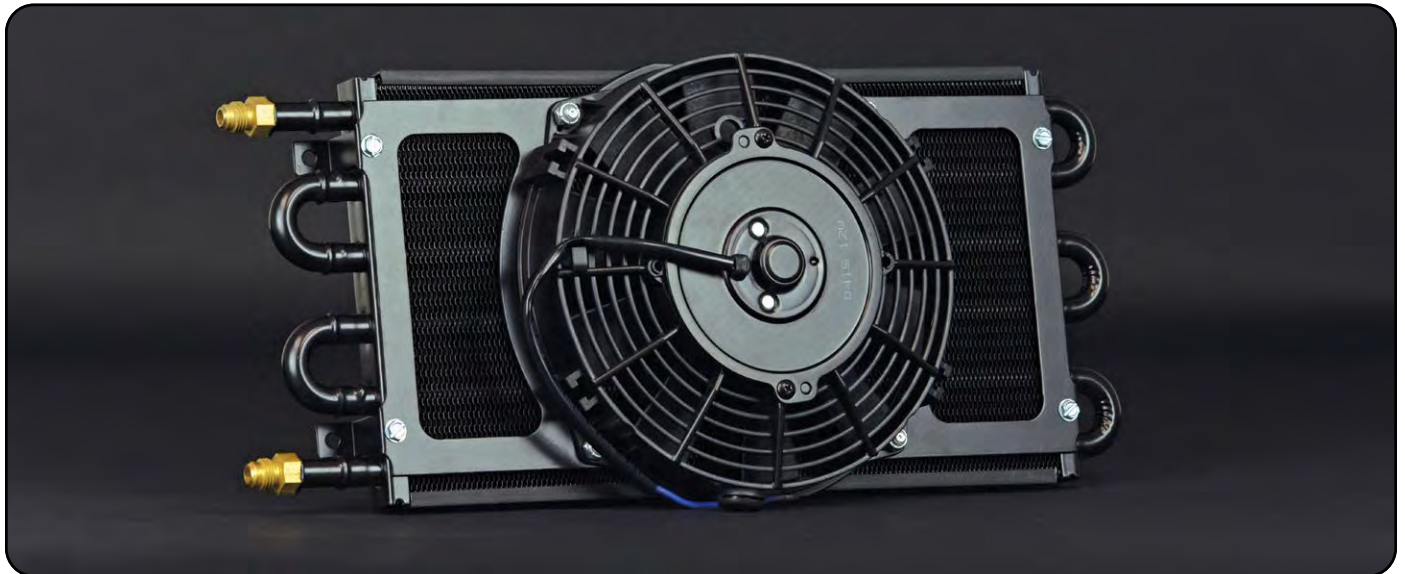

R
REVERSIBLE

Dyno-Cool - Barbed Inlets

- Efficient 6 or 8 pass copper/ aluminum tube and fin cooler with 11/32" Barb inlets
- 475 CFM, reversible 9" electric fan
- Designed for Puller applications
- Black powder coated steel bracket

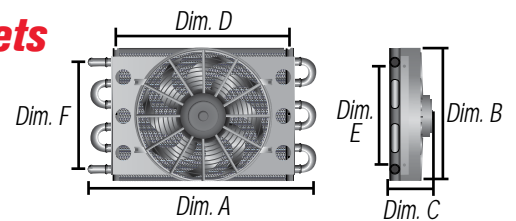

Recommended for:
Transmission Fuel
Power Steering Differential

Cooler Part No.	No. of Passes	Inlet Size	Repl. Core	Repl. Fan	Fluid Capacity	BTU	Dim. A (Width)	Dim. B (Height)	Dim. C (Depth)	Dim. D (Mounting)	Dim. E (Mounting)	Dim. F (Inlet to Inlet)
12740	6	11/32" Barb	13101	16908	4 oz.	5000	12 3/4"	7 5/8"	3 5/8"	10 7/8"	5"	6 1/4"
12741	6	11/32" Barb	13103	16908	4.5 oz.	6000	16 5/8"	7 5/8"	3 3/4"	14 3/4"	5"	6 1/4"
12742	8	11/32" Barb	13107	16909	10 oz.	7500	12 3/4"	10 1/4"	3 5/8"	10 7/8"	5"	8 3/4"
12743	8	11/32" Barb	13104	16909	5 oz.	8000	16 5/8"	10 1/4"	3 3/4"	14 3/4"	5"	8 3/4"



R
REVERSIBLE

Dyno-Cool - 6AN Inlets

- Efficient 6 or 8 pass copper/ aluminum tube and fin cooler with -6 AN or -8 AN " Barb inlets
- 475 CFM, reversible 9" electric fan
- Designed for Puller applications
- Black powder coated steel bracket

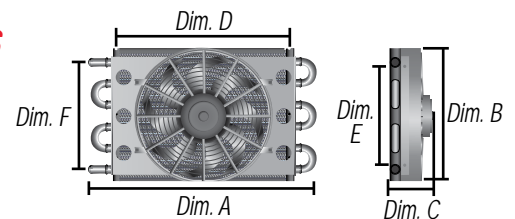

Recommended for:
Transmission Fuel
Power Steering Differential

Cooler Part No.	No. of Passes	Inlet Size	Repl. Core	Repl. Fan	Fluid Capacity	BTU	Dim. A (Width)	Dim. B (Height)	Dim. C (Depth)	Dim. D (Mounting)	Dim. E (Mounting)	Dim. F (Inlet to Inlet)
12730	6	-6 AN	13311	16908	4 oz.	5000	13 5/8"	7 5/8"	3 5/8"	10 7/8"	5"	6 1/4"
12731	6	-6 AN	13313	16908	4.5 oz.	6000	17 1/2"	7 5/8"	3 3/4"	14 3/4"	5"	6 1/4"
12732	8	-6 AN	13317	16909	10 oz.	7500	13 5/8"	10 1/4"	3 5/8"	10 7/8"	5"	8 3/4"
12733	8	-6 AN	13314	16909	5 oz.	8000	17 1/2"	10 1/4"	3 3/4"	14 3/4"	5"	8 3/4"



THE LEADER IN PERFORMANCE COOLING

Remote Fluid Coolers

Plate & Fin Fluid Cooler

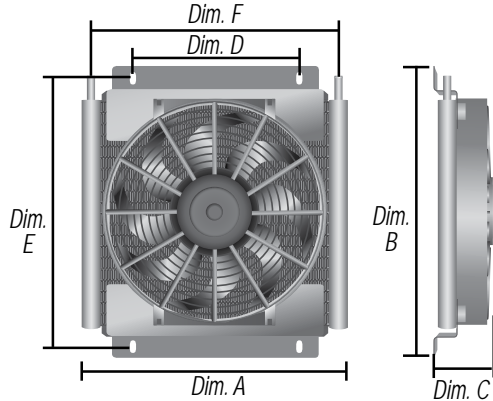

- Efficient 18 row plate and fin cooler
- 400 CFM, reversible 8" electric fan
- Clear anodized aluminum brackets

Recommended for:
Transmission **Fuel**
Power Steering **Differential**



Cooler Part No.	No. of Rows	Inlet Size	Repl. Core	Repl. Fan	Fluid Capacity	BTU	Dim. A (Width)	Dim. B (Height)	Dim. C (Depth)	Dim. D (Mounting)	Dim. E (Mounting)	Dim. F (Inlet to Inlet)
NEW 13735	18	11/32" Barb	33503	16618	5.5 oz.	20000	11"	11"	3 3/4"	5 1/2"	10"	10 1/4"

Fluid Control Thermostats



Controlled Closed Circuit

Below 180°F the valve opens, with 90% of the fluid bypassing the cooler. The remaining 10% of the oil flows through the cooler, maintaining constant system pressure, preventing air pockets and eliminating cold oil shock.



20 GALLONS PER MINUTE

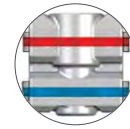

Maximum Flow

When temperatures exceed 180°F the thermostatic valve closes, allowing 100% flow through the oil cooler. This allows for ultimate control of oil temperatures under normal to extreme conditions.



Thermostat with Fittings

Inlets	Part No.
3/8" NPT	13011
1/2" NPT	15719



Thermostat Only

Inlets	Part No.
3/8" NPT	25011
1/2" NPT	25719



Thermostat with Bracket Kit

Inlets	Part No.
3/8" NPT	25791
1/2" NPT	25792



Installation Kit Only

Inlets	Part No.
3/8" NPT	13026
1/2" NPT	15726

In-line Fan Control



THE LEADER IN PERFORMANCE COOLING



Available in -6 AN, -8 AN, or -10 AN anodized aluminum housing

Premium Series In-line Fan Control

- Offered in 180°F or 190°F Turn-On temperature
- Turn-Off temperature is preset 15° below turn-on temperature
- Black Anodized aluminum swivel housing allows T-stat to be clocked in the desired position

Inlets	180° Part No.	190° Part No.
-6 AN x -6 AN	35020	35025
-8 AN x -8 AN	35021	35026
-10 AN x -10 AN	35022	35027



Available in -6 AN, or -8 AN anodized aluminum housing

Standard Series In-line Fan Control

- 180°F Turn-On temperature
- Turn-Off temperature is preset 15° below turn-on temperature
- Black Anodized Aluminum AN hose barb adapter fittings included

Inlets	Part No.
-6 AN x -6 AN	13021
-8 AN x -8 AN	15721

Remote Fluid Coolers - Quick Guide

Remote Fluid Cooler Kits

Size	Part No.	Series	Description	Width	Height	Depth	Page	
10" to 15" Width	NEW 13735	Plate & Fin Cooler	11/32", 18 Row Plate & Fin Cooler	11"	11"	3 3/4"	16	
	65860	Hi-Flow Racing Cooler	18 Row	11 7/8"	12 3/8"	6 5/8"	7	
	65861	Hi-Flow Racing Cooler	18 Row	11 7/8"	12 3/8"	8 1/2"	7	
	12740	Dyno-Cool	11/32", 6 Pass Tube & Fin Cooler	12 3/4"	7 5/8"	3 5/8"	15	
	13730	Econo-Cool	11/32" Barb, 6 Pass Tube & Fin Cooler	12 3/4"	7 5/8"	3 3/4"	14	
	15830	Econo-Cool	1/2" Barb, 6 Pass Tube & Fin Cooler	12 3/4"	7 5/8"	3 3/4"	14	
	13754	Atomic-Cool / Weatherproof	-6 & -8 AN, 16 Row Plate & Fin Cooler	12 3/4"	9 3/8"	3 15/16"	11	
	13750	Atomic-Cool	-6 AN, 16 Row Plate & Fin Cooler	12 3/4"	9 3/8"	4 5/16"	11	
	15850	Atomic-Cool	-8 AN, 16 Row Plate & Fin Cooler	12 3/4"	9 3/8"	4 5/16"	11	
	12742	Dyno-Cool	11/32", 8 Pass Tube & Fin Cooler	12 3/4"	10 1/4"	3 5/8"	15	
	12730	Dyno-Cool	-6 AN, 6 Pass Tube & Fin Cooler	13 5/8"	7 5/8"	3 5/8"	15	
	12732	Dyno-Cool	-6 AN, 8 Pass Tube & Fin Cooler	13 5/8"	10 1/4"	3 5/8"	15	
	15230	Econo-Cool Dual Circuit	-8 AN, 4 & 2 Pass Tube & Fin Cooler	13 15/16"	7 5/8"	3 3/4"	14	
	13740	Hyper-Cool Dual	-6 AN, 19 Row Stack Plate Cooler	13"	7 3/8"	4 7/8"	9	
	15840	Hyper-Cool Dual	-8 AN, 19 Row Stack Plate Cooler	13"	7 7/16"	4 7/8"	9	
	15845	Hyper-Cool Dual	-10 AN, 19 Row Stack Plate Cooler	13"	7 9/16"	4 7/8"	9	
	13760	Hyper-Cool	-6 AN, 25 Row Stack Plate Cooler	13"	10"	5 5/8"	9	
	15860	Hyper-Cool	-8 AN, 25 Row Stack Plate Cooler	13"	10"	5 5/8"	9	
	15865	Hyper-Cool	-10 AN, 25 Row Stack Plate Cooler	13"	10"	5 5/8"	9	
	13764	Hyper-Cool / Weatherproof	7/8"-14 o-ring, 25 Row Stack Plate Cooler	13"	10"	6 3/4"	9	
	13870	Hyper Cool Extreme	-6 AN, 40 Row Stack Plate Cooler	13"	14 7/8"	5 5/8"	9	
	15870	Hyper Cool Extreme	-8 AN, 40 Row Stack Plate Cooler	13"	14 7/8"	5 5/8"	9	
	15875	Hyper Cool Extreme	-10 AN, 40 Row Stack Plate Cooler	13"	14 7/8"	5 5/8"	9	
	15876	Hyper Cool Extreme	-12 AN, 40 Row Stack Plate Cooler	13"	14 7/8"	5 5/8"	9	
	65840	Hi-Flow Racing Cooler Dual	11 Row		15"	8 1/4"	7"	7
	13720	Electra-Cool	-6 AN, 8 Pass Tube & Fin Cooler		15 3/4"	11 1/2"	4"	13
	15220	Electra-Cool Dual Circuit	-8 AN, 4 & 4 Pass Tube & Fin Cooler		15 3/4"	11 1/2"	4"	13
	15820	Electra-Cool	-8 AN, 8 Pass Tube & Fin Cooler		15 3/4"	11 1/2"	4"	13
	13700	Electra-Cool	-6 AN, 16 Pass Tube & Fin Cooler		15 3/4"	11 1/2"	5"	13
	15200	Electra-Cool Dual Circuit	-8 AN, 8 & 8 Pass Tube & Fin Cooler		15 3/4"	11 1/2"	5"	13
	15800	Electra-Cool	-8 AN, 16 Pass Tube & Fin Cooler		15 3/4"	11 1/2"	5"	13
	16" to 25" Width	12741	Dyno-Cool	11/32", 6 Pass Tube & Fin Cooler	16 5/8"	7 5/8"	3 3/4"	15
12743		Dyno-Cool	11/32", 8 Pass Tube & Fin Cooler	16 5/8"	10 1/4"	3 3/4"	15	
12731		Dyno-Cool	-6 AN, 6 Pass Tube & Fin Cooler	17 1/2"	7 5/8"	3 3/4"	15	
12733		Dyno-Cool	-6 AN, 8 Pass Tube & Fin Cooler	17 1/2"	10 1/4"	3 3/4"	15	

Remote Fluid Cooler - Transmission Oil Cooler Kits

Size	Part No.	Series	Description	Width	Height	Depth	Page
10" to 15" Width	13950	Atomic-Cool	-6 AN, 16 Row Plate & Fin Cooler	12 3/4"	9 3/8"	4 5/16"	11
	15950	Atomic-Cool	-8 AN, 16 Row Plate & Fin Cooler	12 3/4"	9 3/8"	4 5/16"	11
	13960	Hyper-Cool	-6 AN, 25 Row Stack Plate Cooler	13"	10"	5 5/8"	9
	15960	Hyper-Cool	-8 AN, 25 Row Stack Plate Cooler	13"	10"	5 5/8"	9
	13900	Electra-Cool	-6 AN, 16 Pass Tube & Fin Cooler	15 3/4"	11 1/2"	5"	13
	15900	Electra-Cool	-8 AN, 16 Pass Tube & Fin Cooler	15 3/4"	11 1/2"	5"	13

Remote Fluid Cooler - Engine Oil Cooler Kits

Size	Part No.	Series	Description	Width	Height	Depth	Page
10" to 15" Width	15660	Hyper-Cool	-8 AN, 25 Row Stack Plate Cooler	13"	10"	5 5/8"	9
	15450	Atomic-Cool	-8 AN, 16 Pass Plate & Fin Cooler	15 3/4"	11 1/2"	5"	11
	15500	Electra-Cool	-8 AN, 16 Pass Tube & Fin Cooler	15 3/4"	11 1/2"	5"	13

SERIES 9500 Plate & Fin Fluid Cooler Kits



THE LEADER IN PERFORMANCE COOLING

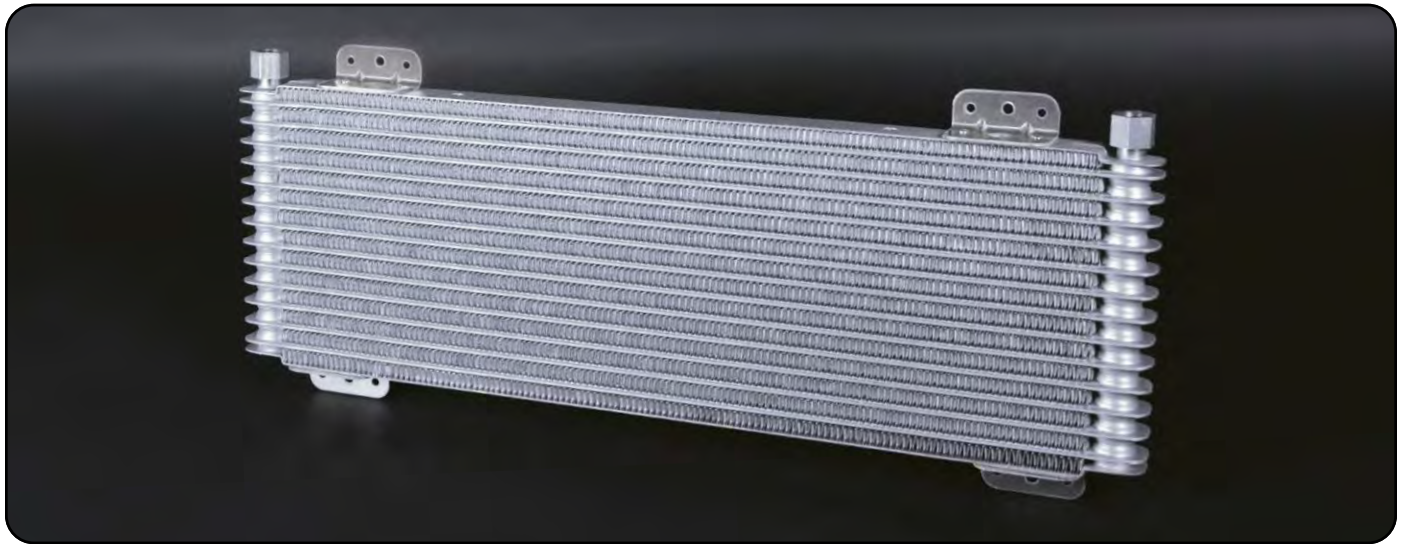

Features and Benefits

- Integrated, high-flow turbulators
- Sturdy furnace-brazed aluminum construction tested to 250 P.S.I.
- 5/8" Inverted Flare Female inlets
- 4 integrated mounting points
- Recommended for: Transmission, Power Steering, Differential and Fuel

Dimensions

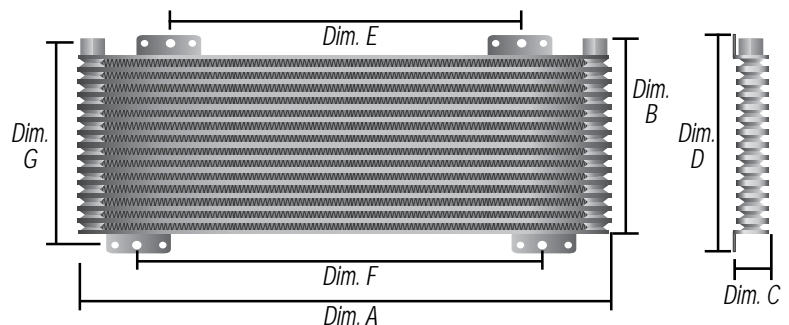

Transmission Cooler Kit

- Extends transmission service life by preventing heat-related component failure & fluid breakdown
- Improves transmission performance
- Hardware kit includes 3/8" barb fittings, high-pressure/high temperature hose, radiator adapter & mounting hardware

Trans Cooler Kit Part No.	Cooler Part No.	No. of Rows	Inlet Size	Fluid Capacity	GVW	BTU	Dim. A (Width)	Dim. B (Height)	Dim. C (Depth)	Dim. D (Overall Height)	Dim. E (Mounting)	Dim. F (Mounting)	Dim. G (Mounting)	Dim. H (Inlet to Inlet)
NEW 13633	33633	13	5/8" Inverted Flare	20 oz.	34000	33000	22 3/4"	8"	1 1/4"	9 1/4"	15 3/4"	17 3/4"	8 1/2"	21 3/8"



THE LEADER IN PERFORMANCE COOLING

SERIES 10000

Stack Plate Fluid Coolers



Features and Benefits

- Ultra efficient heat-exchanger with built-in high-flow turbulators
- Sturdy furnace-brazed aluminum construction tested to 250 P.S.I.
- 7/8"-14 UNF O-Ring cooler inlets & 4 integrated mounting points
- Available in 6 cooler core sizes: 10, 16, 19, 25, 34 & 40-rows
- Recommended for: Engine, Transmission, Power Steering, Differential and Fuel

Dimensions

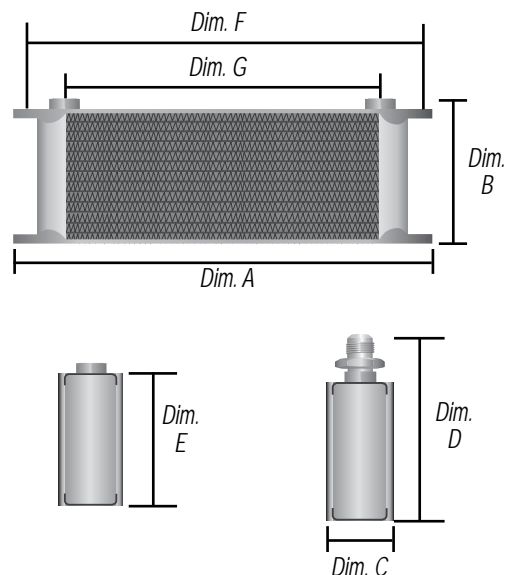

SERIES 10000 Stack Plate Fluid Coolers



THE LEADER IN PERFORMANCE COOLING



40 row



34 row



25 row



19 row



16 row



10 row

COOLER CORE ONLY

Cooler Part No.	No. of Rows	Capacity	BTU	Fitting Size	Dim. A (Width)	Dim. B (Height)	Dim. C (Depth)	Dim. D (Overall Height)	Dim. E (Mounting)	Dim. F (Mounting)	Dim. G (Inlet)
51078	10	6 oz.	20000	No fittings	13"	3 5/8"	2"	-	2 7/8"	12 1/4"	10"
51006	10	6 oz.	20000	-6 AN Male	13"	3 5/8"	2"	4 7/16"	2 7/8"	12 1/4"	10"
51008	10	6 oz.	20000	-8 AN Male	13"	3 5/8"	2"	4 9/16"	2 7/8"	12 1/4"	10"
51010	10	6 oz.	20000	-10 AN Male	13"	3 5/8"	2"	4 11/16"	2 7/8"	12 1/4"	10"
51678	16	10 oz.	32000	No fittings	13"	5 1/2"	2"	-	4 7/8"	12 1/4"	10"
51606	16	10 oz.	32000	-6 AN Male	13"	5 1/2"	2"	6 7/16"	4 7/8"	12 1/4"	10"
51608	16	10 oz.	32000	-8 AN Male	13"	5 1/2"	2"	6 9/16"	4 7/8"	12 1/4"	10"
51610	16	10 oz.	32000	-10 AN Male	13"	5 1/2"	2"	6 11/16"	4 7/8"	12 1/4"	10"
51978	19	12 oz.	37000	No fittings	13"	6 3/8"	2"	-	5 9/16"	12 1/4"	10"
51906	19	12 oz.	37000	-6 AN Male	13"	6 3/8"	2"	7 5/16"	5 9/16"	12 1/4"	10"
51908	19	12 oz.	37000	-8 AN Male	13"	6 3/8"	2"	7 1/2"	5 9/16"	12 1/4"	10"
51910	19	12 oz.	37000	-10 AN Male	13"	6 3/8"	2"	7 9/16"	5 9/16"	12 1/4"	10"
52578	25	16 oz.	46000	No fittings	13"	8 1/4"	2"	-	7 7/16"	12 1/4"	10"
52506	25	16 oz.	46000	-6 AN Male	13"	8 1/4"	2"	9 3/16"	7 7/16"	12 1/4"	10"
52508	25	16 oz.	46000	-8 AN Male	13"	8 1/4"	2"	9 5/16"	7 7/16"	12 1/4"	10"
52510	25	16 oz.	46000	-10 AN Male	13"	8 1/4"	2"	9 3/8"	7 7/16"	12 1/4"	10"
53478	34	20 oz.	59000	No fittings	13"	10 7/8"	2"	-	10 1/16"	12 1/4"	10"
53406	34	20 oz.	59000	-6 AN Male	13"	10 7/8"	2"	11 7/8"	10 1/16"	12 1/4"	10"
53408	34	20 oz.	59000	-8 AN Male	13"	10 7/8"	2"	12"	10 1/16"	12 1/4"	10"
53410	34	20 oz.	59000	-10 AN Male	13"	10 7/8"	2"	12 1/16"	10 1/16"	12 1/4"	10"
54078	40	26 oz.	60000	No fittings	13"	12 7/8"	2"	-	12"	12 1/4"	10"
54006	40	26 oz.	60000	-6 AN Male	13"	12 7/8"	2"	13 3/4"	12"	12 1/4"	10"
54008	40	26 oz.	60000	-8 AN Male	13"	12 7/8"	2"	13 15/16"	12"	12 1/4"	10"
54010	40	26 oz.	60000	-10 AN Male	13"	12 7/8"	2"	14"	12"	12 1/4"	10"



THE LEADER IN PERFORMANCE COOLING

SERIES 10000

Stack Plate Fluid Cooler Kits



Transmission Cooler Kits

- Extends transmission service life by preventing heat-related component failure & fluid breakdown
- Improves transmission performance
- Hardware kit includes -6AN fittings, hose barb adapters, high-pressure/high temperature hose, Insta-Dapt radiator adapter & mounting hardware

Trans Cooler Kit Part No.	Repl. Cooler Part No.	No. of Rows	Capacity	BTU	Inlet Size	Dim. A (Width)	Dim. B (Height)	Dim. C (Depth)	Dim. D (Overall Height)	Dim. E (Mounting)	Dim. F (Mounting)	Dim. G (Inlet)
13401	51078	10	6 oz.	20000	-6 AN Male	13"	4"	2"	4 7/16"	2 7/8"	12 1/4"	10"
13402	51678	16	10 oz.	32000	-6 AN Male	13"	6"	2"	6 7/16"	4 7/8"	12 1/4"	10"
13403	51978	19	12 oz.	37000	-6 AN Male	13"	7"	2"	7 5/16"	5 3/4"	12 1/4"	10"

SANDWICH ADAPTER KIT



Engine Oil Cooler Kits - Sandwich

- Reduces oil temperatures
- Helps reduce coolant temperature
- Extends engine life
- Hardware kit includes 180°F thermostatic sandwich adapter, hose barb adapters, high-pressure/high temperature hose & mounting hardware

Engine Oil Cooler Kit Part No.	Repl. Cooler Part No.	No. of Rows	Capacity	BTU	Inlet Size	Dim. A (Width)	Dim. B (Height)	Dim. C (Depth)	Dim. D (Overall Height)	Dim. E (Mounting)	Dim. F (Mounting)	Dim. G (Inlet)
15602	51078	10	6 oz.	20000	-8 AN Male	13"	4"	2"	4 9/16"	2 7/8"	12 1/4"	10"
15603	51078	10	6 oz.	20000	-8 AN Male	13"	4"	2"	4 9/16"	2 7/8"	12 1/4"	10"
15604	51078	10	6 oz.	20000	-8 AN Male	13"	4"	2"	4 9/16"	2 7/8"	12 1/4"	10"
15605	51078	10	6 oz.	20000	-8 AN Male	13"	4"	2"	4 9/16"	2 7/8"	12 1/4"	10"

SPIN-ON ADAPTER KIT



Engine Oil Cooler Kits - Spin-On

- Reduces oil temperatures
- Helps reduce coolant temperature
- Relocates filter mount (Uses Fram PH8A equivalent filter)
- Hardware kit includes spin-on adapter, ports-up filter mount, hose barb adapters, high-pressure/high temperature hose & mounting hardware

Engine Oil Cooler Kit Part No.	Repl. Cooler Part No.	No. of Rows	Capacity	BTU	Inlet Size	Dim. A (Width)	Dim. B (Height)	Dim. C (Depth)	Dim. D (Overall Height)	Dim. E (Mounting)	Dim. F (Mounting)	Dim. G (Inlet)
15651	51078	10	6 oz.	20000	-8 AN Male	13"	4"	2"	4 9/16"	2 7/8"	12 1/4"	10"

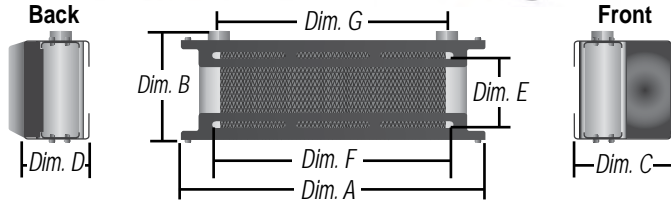

Scoop Cooler Kit

- Aluminum mounting system, mounts to chassis rail
- Designed to capture & redirect airflow for max cooling
- Scoop shroud can be mounted to either side of cooler
- Highly efficient 10 Row, Series 10000 Cooler

Cooler Kit Part No.	Repl. Cooler Part No.	No. of Rows	Capacity	BTU	Inlet Size	Dim. A (Width)	Dim. B (Height)	Dim. C (Depth)	Dim. D (Depth)	Dim. E (Mounting)	Dim. F (Mounting)	Dim. G (Inlet)
50100	51078	10	6 oz.	20000	-10AN / 7/8"-14	13"	4"	5" Front	3 1/4" Back	2 3/16"	10 1/4" Max	10"

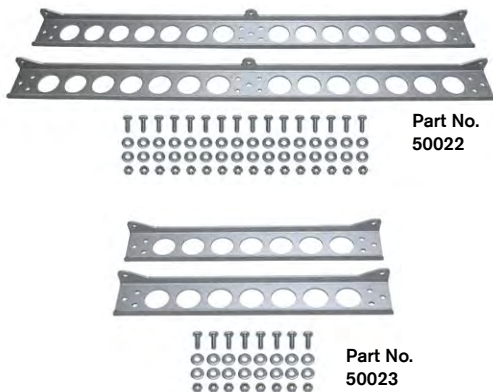
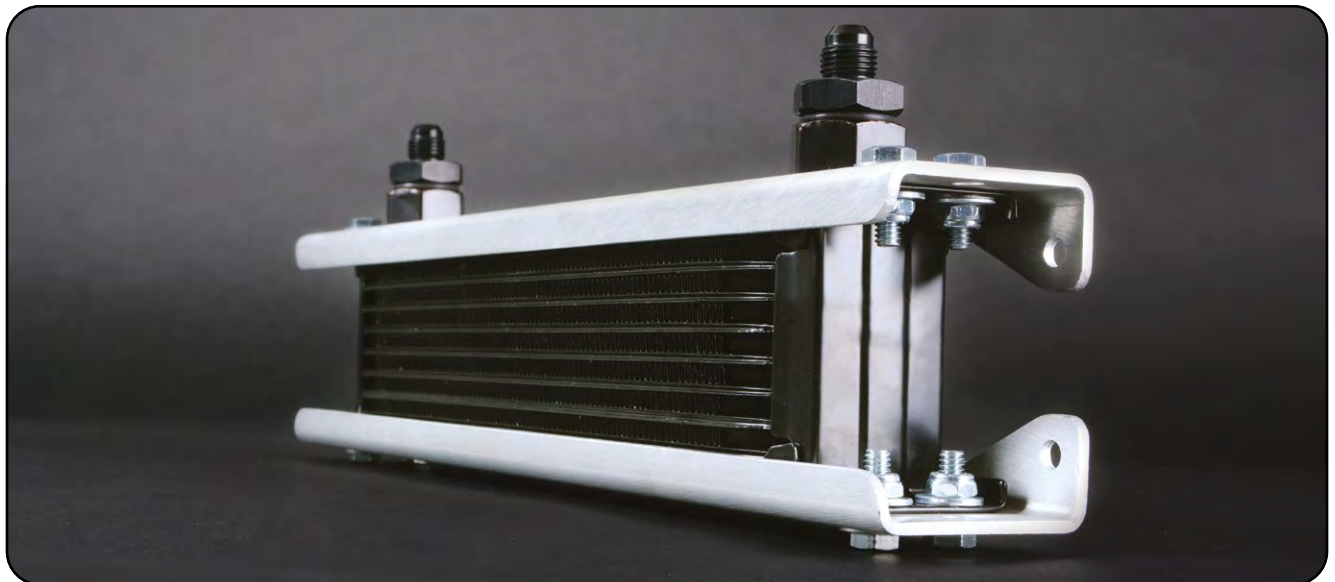

Aluminum Mounting Brackets

- Heavy-Duty aluminum construction, clear anodized
- Symmetrical design makes multiple mounting configurations possible
- Brackets can be flipped for inside or outside mounting
- Available for Single or Dual Series 10000 cooler(s)

Part No.	Bracket Configuration	Width	Deep	Mounting Width
50022	Dual	27 7/8"	2 1/4"	13 1/2" / 13 1/2"
50023	Single	14 1/4"	2 1/4"	13 1/2"

Steel Mounting Brackets

- Multi-position brackets
- Black powder coated steel brackets



Part No.
50020



THE LEADER IN PERFORMANCE COOLING

SERIES 9000

Plate & Fin Fluid Cooler Kits



Features and Benefits

- Integrated, high-flow turbulators
- Sturdy furnace-brazed aluminum construction tested to 250 P.S.I.
- 1/2" NPT female cooler inlets & 4 integrated mounting points
- Available in 5 cooler core sizes: 5, 9, 13, 17 & 21 rows
- Recommended for: Engine, Transmission, Power Steering, Differential and Fuel

Dimensions

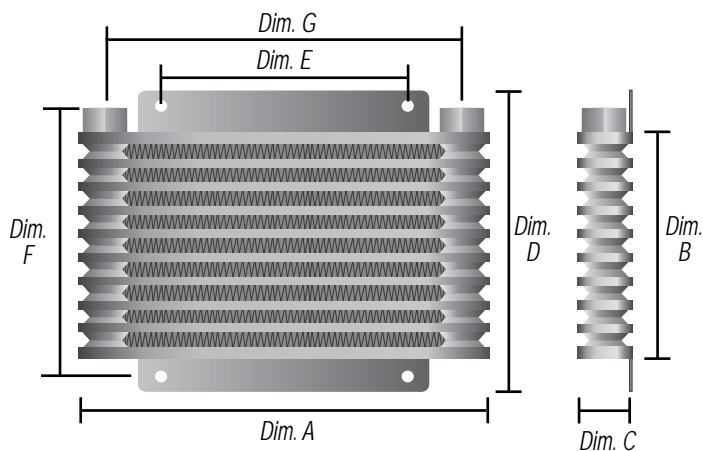

SERIES 9000 Plate & Fin Fluid Cooler Kits



21 row



17 row



13 row



9 row



5 row

COOLER CORE ONLY

Cooler Part No.	No. of Rows	Capacity	BTU	Inlet Size	Dim. A (Width)	Dim. B (Height)	Dim. C (Depth)	Dim. D (Overall Height)	Dim. E (Mounting)	Dim. F (Mounting)	Dim. G (Inlet)
33601	5	3 oz.	12500	1/2" FPT	9 3/4"	2 3/8"	1 1/4"	4 1/8"	6 11/16"	3 5/16"	8 1/2"
33602	9	6 oz.	14000	1/2" FPT	9 3/4"	4 1/2"	1 1/4"	6 1/4"	6 11/16"	5 7/16"	8 1/2"
33603	13	10 oz.	21000	1/2" FPT	9 3/4"	6 11/16"	1 1/4"	8 7/16"	6 11/16"	7 9/16"	8 1/2"
33604	17	12 oz.	23500	1/2" FPT	9 3/4"	8 7/8"	1 1/4"	10 5/8"	6 11/16"	9 13/16"	8 1/2"
NEW 33605	21	14 oz.	25000	1/2" FPT	9 3/4"	11"	1 1/4"	12 13/16"	6 11/16"	12"	8 1/2"



Transmission Cooler Kits

- Extends transmission service life by preventing heat-related component failure & fluid breakdown
- Improves transmission performance
- Hardware kit includes 3/8" barb fittings, high-pressure/high temperature hose, Insta-Dapt radiator adapter & mounting hardware

Trans Cooler Kit Part No.	Repl. Cooler Part No.	No. of Rows	Capacity	GVW	BTU	Inlet Size	Hose Barb Size	Dim. A (Width)	Dim. B (Height)	Dim. C (Depth)	Dim. D (Overall Height)	Dim. E (Mounting)	Dim. F (Mounting)	Dim. G (Inlet)
13611	33601	5	3 oz.	16000	12500	1/2" FPT	3/8"	9 3/4"	2 3/8"	1 1/4"	4 1/8"	6 11/16"	3 5/16"	8 1/2"
13612	33602	9	6 oz.	18000	14000	1/2" FPT	3/8"	9 3/4"	4 1/2"	1 1/4"	6 1/4"	6 11/16"	5 7/16"	8 1/2"
13613	33603	13	10 oz.	22000	21000	1/2" FPT	3/8"	9 3/4"	6 11/16"	1 1/4"	8 7/16"	6 11/16"	7 9/16"	8 1/2"
13614	33604	17	12 oz.	24000	23500	1/2" FPT	3/8"	9 3/4"	8 7/8"	1 1/4"	10 5/8"	6 11/16"	9 13/16"	8 1/2"
NEW 13615	33605	21	14 oz.	26500	25000	1/2" FPT	3/8"	9 3/4"	11"	1 1/4"	12 13/16"	6 11/16"	12"	8 1/2"



Engine Oil Cooler Kits - Sandwich

- Reduces oil temperatures
- Helps reduce coolant temperature
- Hardware kit includes spin-on adapter, ports-up filter mount, hose barb adapters, high-pressure/high temperature hose & mounting hardware

Engine Oil Cooler Kit	Repl. Cooler Part No.	No. of Rows	Capacity	BTU	Inlet Size	Hose Barb Size	Dim. A (Width)	Dim. B (Height)	Dim. C (Depth)	Dim. D (Overall Height)	Dim. E (Mounting)	Dim. F (Mounting)	Dim. G (Inlet)
15405	33603	13	10 oz.	21000	1/2" FPT	3/8"	9 3/4"	6 11/16"	1 1/4"	8 7/16"	6 11/16"	7 9/16"	8 1/2"



Engine Oil Cooler Kits - Spin-On

- Reduces oil temperatures
- Helps reduce coolant temperature
- Relocates filter mount (Uses Fram PH8A equivalent filter)
- Hardware kit includes spin-on adapter, ports-up filter mount, hose barb adapters, high-pressure/high temperature hose & mounting hardware

Engine Oil Cooler Kit	Repl. Cooler Part No.	No. of Rows	Capacity	BTU	Inlet Size	Hose Barb Size	Dim. A (Width)	Dim. B (Height)	Dim. C (Depth)	Dim. D (Overall Height)	Dim. E (Mounting)	Dim. F (Mounting)	Dim. G (Inlet)
15451	33603	13	10 oz.	21000	1/2" FPT	3/8"	9 3/4"	6 11/16"	1 1/4"	8 7/16"	6 11/16"	7 9/16"	8 1/2"



THE LEADER IN PERFORMANCE COOLING

SERIES 8000

Plate & Fin Fluid Cooler Kits



Features and Benefits

- **Integrated high-flow turbulators for maximum cooling efficiency**
- **Sturdy furnace-brazed aluminum construction tested to 250 p.s.i.**
- **11/32" hose barb inlets**
- **Available in 4 cooler core sizes: 9, 13, 18 & 24-rows**
- **Recommended for: Transmission, Power Steering, Differential and Fuel**

Dimensions

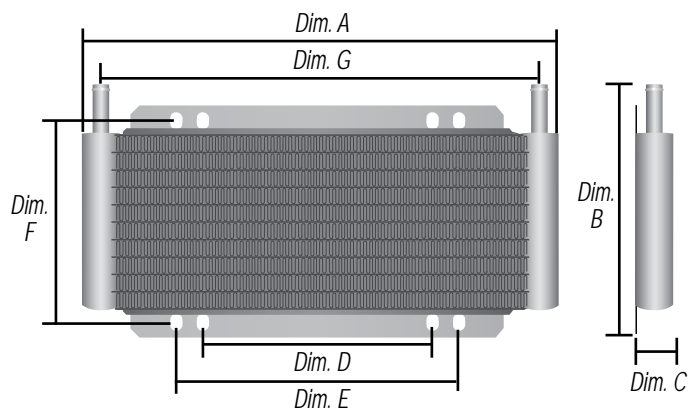

SERIES 8000 Plate & Fin Fluid Cooler Kits



24 row



18 row
(Inverted Flare)



18 row



13 row



9 row

COOLER CORE ONLY

Part No.	No. of Rows	Fluid Capacity	BTU	Inlet Size	Dim. A (Width)	Dim. B (Height)	Dim. C (Depth)	Dim. D (Mounting)	Dim. E (Mounting)	Dim. F (Mounting Height)	Dim. G (Inlets)
33501	9	2.5 oz.	11500	11/32" Barb	11"	5 3/4"	7/8"	5 1/4"	6 3/4"	4 1/2"	10 1/4"
33502	13	4 oz.	13500	11/32" Barb	11"	7 1/4"	7/8"	5 1/4"	6 3/4"	6 1/8"	10 1/4"
33503	18	5.5 oz.	20000	11/32" Barb	11"	9 1/4"	7/8"	5 1/4"	6 3/4"	8"	10 1/4"
33504	24	8 oz.	23000	11/32" Barb	11"	11 3/4"	7/8"	5 1/4"	6 3/4"	10 1/2"	10 1/4"
NEW 33523	18	5.5 oz.	20000	1/2"-20 Inverted Flare	11"	8 13/16"	7/8"	5 1/4"	6 3/4"	8"	10 1/4"



Transmission Cooler Kits

- Extends transmission service life by preventing heat-related component failure & fluid breakdown
- Improves transmission performance
- Sturdy furnace-brazed aluminum construction
- Integrated, high-flow turbulators maximize cooling efficiency
- Hardware kit includes high pressure/high temperature hose, Insta-Dapt radiator adapter & mounting hardware

Install Kit Only Part # 12006

Part No.	Repl. Cooler Part No.	No. of Rows	Fluid Capacity	GVW	BTU	Inlet Size	Dim. A (Width)	Dim. B (Height)	Dim. C (Depth)	Dim. D (Mounting)	Dim. E (Mounting)	Dim. F (Mounting Height)	Dim. G (Inlets)
13501	33501	9	2.5 oz.	15500	11500	11/32" Barb	11"	5 3/4"	7/8"	5 1/4"	6 3/4"	4 1/2"	10 1/4"
13502	33502	13	4 oz.	18000	13500	11/32" Barb	11"	7 1/4"	7/8"	5 1/4"	6 3/4"	6 1/8"	10 1/4"
13503	33503	18	5.5 oz.	20500	20000	11/32" Barb	11"	9 1/4"	7/8"	5 1/4"	6 3/4"	8"	10 1/4"
13504	33504	24	8 oz.	22500	23000	11/32" Barb	11"	11 3/4"	7/8"	5 1/4"	6 3/4"	10 1/2"	10 1/4"
NEW 13523	33523	18	5.5 oz.	20500	20000	1/2"-20 Inverted Flare	11"	8 13/16"	7/8"	5 1/4"	6 3/4"	8"	10 1/4"



Power Steering Cooler Kits

- Extends pump & seal life
- Reduces heat-related pump failure
- 11/32" hose barb inlets
- Integrated, high-flow turbulators maximize cooling efficiency
- Hardware kit includes high pressure/high temperature hose, and mounting hardware

Install Kit Only Part # 12006

Part No.	Repl. Cooler Part No.	No. of Rows	Fluid Capacity	BTU	Inlet Size	Dim. A (Width)	Dim. B (Height)	Dim. C (Depth)	Dim. D (Mounting)	Dim. E (Mounting)	Dim. F (Mounting Height)	Dim. G (Inlets)
13215	33501	9	2.5 oz.	11500	11/32" Barb	11"	5 3/4"	7/8"	5 1/4"	6 3/4"	4 1/2"	10 1/4"



THE LEADER IN PERFORMANCE COOLING

SERIES 7000

Tube & Fin Fluid Coolers



Features and Benefits

- Prevents heat-related component failure & fluid breakdown
- 1/2" copper tubing expanded into aluminum cooling fins
- Black powder coated finish
- Extruded plastic fin guards
- Recommended for: Engine, Transmission, Power Steering, Differential and Fuel



Dimensions

Single Circuit

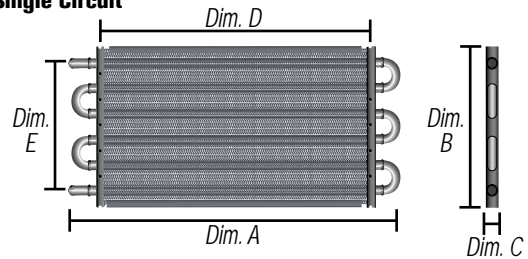

Dual Circuit

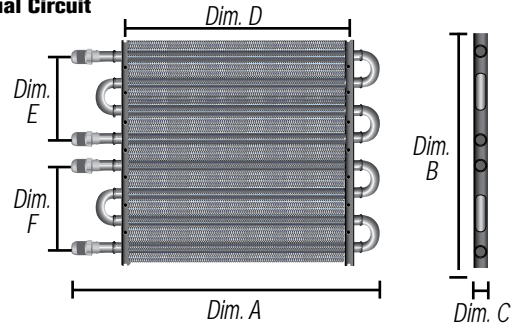

SERIES 7000 Tube & Fin Fluid Coolers



THE LEADER IN PERFORMANCE COOLING



COOLER CORE ONLY

Cooler Part No.	No. of Passes	Fluid Capacity	BTU	Inlet Size	Dim. A (Width)	Dim. B (Height)	Dim. C (Depth)	Dim. D (Mounting)	Dim. E (Inlet to Inlet)	Dim. F (Inlet to Inlet)
13309	4	2.5 oz.	3500	-6 AN	8 1/8"	5 1/8"	3/4"	4 7/8"	3 3/4"	--
13310	2	1.5 oz.	1500	-6 AN	8 1/8"	2 5/8"	1 3/4"	5 1/4"	1 1/4"	--
13311	4	4 oz.	3500	-6 AN	13 1/2"	5 1/8"	3/4"	9 5/8"	3 3/4"	--
13312	4	4.25 oz.	3500	-6 AN	17 1/2"	5 1/8"	3/4"	13 1/2"	3 3/4"	--
13313	6	7 oz.	5500	-6 AN	17 1/2"	7 5/8"	3/4"	13 1/2"	6 1/4"	--
13314	8	11.5 oz.	8000	-6 AN	17 1/2"	10 1/4"	3/4"	13 1/2"	8 3/4"	--
13315	10	13.5 oz.	10000	-6 AN	17 1/2"	12 5/8"	3/4"	13 1/2"	11 1/4"	--
13316	6	6 oz.	5500	-6 AN	13 1/2"	7 5/8"	3/4"	9 5/8"	6 1/4"	--
13317	8	6.25 oz.	7500	-6 AN	13 1/2"	10 1/4"	3/4"	9 5/8"	8 3/4"	--
13318	10	8 oz.	9500	-6 AN	13 1/2"	12 5/8"	3/4"	9 5/8"	11 1/4"	--
Dual Circuit										
13302	6 pass and 4 pass	5.5 oz.	10000	(2) 11/32" (2) 1/2" Barb	16 15/16"	12 5/8"	3/4"	13 1/2"	6 1/4"	3 3/4"
13322	4 pass and 4 pass	8 oz.	8000	(2) 11/32" (2) 1/2" Barb	12 15/16"	10 1/4"	3/4"	9 5/8"	3 3/4"	3 3/4"
15301	8 pass and 8 pass	2.5 oz.	16000	(4) -8AN	13 15/16"	10 1/2"	1 3/4"	9 5/8"	4 1/8"	4 1/8"
15321	4 pass and 4 pass	4 oz.	8000	(4) -8AN	13 15/16"	10 1/4"	3/4"	9 5/8"	3 3/4"	3 3/4"
15331	4 pass and 2 pass	5.5 oz.	6000	(4) -8AN	13 15/16"	7 5/8"	3/4"	9 5/8"	3 3/4"	1 1/4"



THE LEADER IN PERFORMANCE COOLING

SERIES 7000 Tube & Fin Fluid Cooler Kits

6AN Inlets Transmission Cooler Kits

- Extends transmission service life by preventing heat-related component failure & fluid breakdown
- Improves transmission performance
- Hardware kit includes high-pressure/high-temperature hose, Insta-Dapt radiator adapter and mounting hardware



Part No.
13306

Install Kit Only Part # 13065

Trans Cooler Kit Part No.	No. of Passes	Fluid Capacity	GVW	BTU	Inlet Size	Dim. A (Width)	Dim. B (Height)	Dim. C (Depth)	Dim. D (Mounting)	Dim. E (Inlet to Inlet)
13303	6	7 oz.	18500	5500	-6AN	17 1/2"	7 5/8"	3/4"	13 1/2"	6 1/4"
13304	8	11.5 oz.	20500	8000	-6AN	17 1/2"	10 1/4"	3/4"	13 1/2"	8 3/4"
13306	6	6 oz.	15500	5500	-6AN	13 1/2"	7 5/8"	3/4"	9 5/8"	6 1/4"

1 1/32" Barb Inlets Transmission Cooler Kits

- Extends transmission service life by preventing heat-related component failure & fluid breakdown
- Improves transmission performance
- Hardware kit includes high-pressure/high temperature hose, Insta-Dapt radiator adapter & mounting hardware



Part No.
13106

Install Kit Only Part # 13066

Trans Cooler Kit Part No.	No. of Passes	Fluid Capacity	GVW	BTU	Inlet Size	Dim. A (Width)	Dim. B (Height)	Dim. C (Depth)	Dim. D (Mounting)	Dim. E (Inlet to Inlet)
13101	4	4 oz.	12000	3500	11/32" Barb	12 3/4"	5 1/8"	3/4"	9 5/8"	3 3/4"
13102	4	4.25 oz.	14000	3500	11/32" Barb	16 5/8"	5 1/8"	3/4"	13 1/2"	3 3/4"
13103	6	7 oz.	18500	6000	11/32" Barb	16 5/8"	7 5/8"	3/4"	13 1/2"	6 1/4"
13104	8	11.5 oz.	20500	8000	11/32" Barb	16 5/8"	10 1/4"	3/4"	13 1/2"	8 3/4"
13105	10	13.5 oz.	22500	10000	11/32" Barb	16 5/8"	12 5/8"	3/4"	13 1/2"	11 1/4"
13106	6	6 oz.	15500	6000	11/32" Barb	12 3/4"	7 5/8"	3/4"	9 5/8"	6 1/4"
13107	8	6.25 oz.	18200	7500	11/32" Barb	12 3/4"	10 1/4"	3/4"	9 5/8"	8 3/4"
13108	10	8 oz.	20500	9500	11/32" Barb	12 3/4"	12 5/8"	3/4"	9 5/8"	11 1/4"



Engine Oil Cooler Kits - Sandwich

- Reduces oil temperatures
- Helps reduce coolant temperature
- Extends engine life
- Hardware kit includes 180°F thermostatic sandwich adapter, 1/2" hose barb adapters, 1/2" high-pressure/high temperature hose and mounting hardware

Install Kit Only Part # 15751

Engine Oil Cooler Kit Part No.	Repl. Cooler Part No.	No. of Passes	Fluid Capacity	GVW	BTU	Inlet Size	Dim. A (Width)	Dim. B (Height)	Dim. C (Depth)	Dim. D (Mounting)	Dim. E (Inlet to Inlet)
15505	15302	6	7 oz.	18500	6000	11/32" Barb	16 5/8"	7 5/8"	3/4"	13 1/2"	6 1/4"
15502	15302	6	7 oz.	18500	6000	11/32" Barb	16 5/8"	7 5/8"	3/4"	13 1/2"	6 1/4"
15503	15302	6	7 oz.	15500	6000	11/32" Barb	16 5/8"	7 5/8"	3/4"	13 1/2"	6 1/4"



Engine Oil Cooler Kits - Spin-On

- Reduces oil temperatures
- Helps reduce coolant temperature
- Extends engine life
- Relocates filter mount (Uses Fram PH8A equivalent filter)
- Hardware kit includes spin-on adapter, ports-up filter mount, hose barb adapters, high-pressure/high temperature hose and mounting hardware

Cooler Mounting Kit Only Part # 13001
(Plastic rods, foam pads and clips)

Install Kit Only Part # 15748

Engine Oil Cooler Kit Part No.	Repl. Cooler Part No.	No. of Passes	Fluid Capacity	GVW	BTU	Inlet Size	Dim. A (Width)	Dim. B (Height)	Dim. C (Depth)	Dim. D (Mounting)	Dim. E (Inlet to Inlet)
15551	15302	6	7 oz.	18500	6000	11/32" Barb	16 5/8"	7 5/8"	3/4"	13 1/2"	6 1/4"



Power Steering Cooler Kits

- Extends pump and seal life
- Reduces heat-related pump failure
- 1/2" copper tubing expanded into aluminum cooling fins
- Hardware kit includes high-pressure/high-temperature hose, clamps and mounting hardware

Install Kit Only Part # 12006

Power Steering Kit Part No.	Repl. Cooler Part No.	No. of Passes	Fluid Capacity	BTU	Inlet Size	Dim. A (Width)	Dim. B (Height)	Dim. C (Depth)	Dim. D (Mounting)	Dim. E (Inlet to Inlet)
13200	----	2	2.25 oz.	1500	11/32" Barb	12 3/4"	2 5/8"	3/4"	9 5/8"	1 1/4"
13212	13309	4	2.5 oz.	3500	11/32" Barb	8 1/8"	5 1/8"	3/4"	4 7/8"	3 3/4"
13213	----	2	1 oz.	3500	11/32" Barb	8 1/8"	2 5/8"	3/4"	4 7/8"	1 1/4"



THE LEADER IN PERFORMANCE COOLING

Series 7000 Frame Rail Fluid Cooler Kits

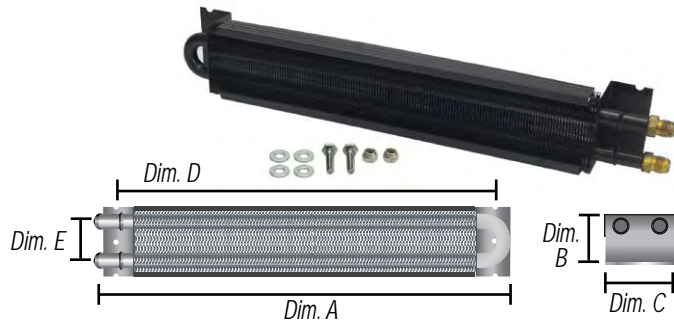

Part No.
13223

Frame Rail Cooler Kit

- Prevents heat-related component failure and fluid breakdown
- 1/2" copper tubing expanded into aluminum cooling fins
- -6 AN hose barb inlets
- Extruded plastic cooling fin guards

Cooler Kit Part No.	No. of Passes	Fluid Capacity	BTU	Inlet Size	Dim. A (Width)	Dim. B (Height)	Dim. C (Depth)	Dim. D (Mounting)	Dim. E (Inlet to Inlet)
13223	2	2.5 oz.	2000	-6 AN	13 3/4"	2 3/4"	1 3/4"	11 3/4"	1 1/4"
13221	2	3.25 oz.	2200	-6 AN	17 3/4"	2 3/4"	1 3/4"	15 1/2"	1 1/4"
13225	2	4.5 oz.	2400	-6 AN	24 3/4"	2 3/4"	1 3/4"	22 3/4"	1 1/4"

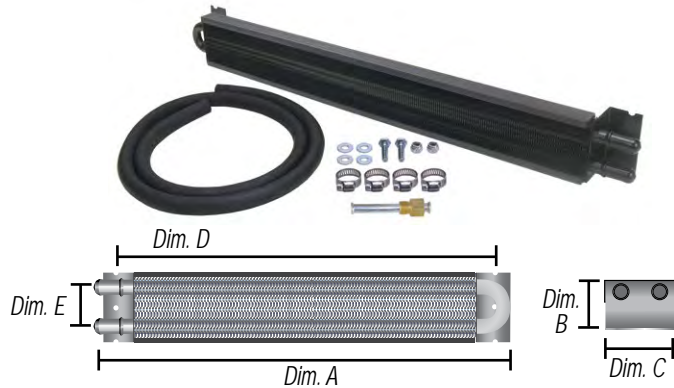

Part No.
13224

Transmission Cooler Kits

- Prevents heat-related transmission failure and fluid breakdown
- 1/2" copper tubing expanded into aluminum cooling fins
- 11/32" hose barb inlets
- Extruded plastic cooling fin guards

Trans Cooler Kit Part No.	Repl. Core	No. of Passes	Fluid Capacity	BTU	Inlet Size	Dim. A (Width)	Dim. B (Height)	Dim. C (Depth)	Dim. D (Mounting)	Dim. E (Inlet to Inlet)
13222	13223	2	2.5 oz.	2000	11/32"	12 3/4"	2 3/4"	1 3/4"	11 3/4"	1 1/4"
13220	13321	2	3.25 oz.	2200	11/32"	16 3/4"	2 3/4"	1 3/4"	15 1/2"	1 1/4"
13224	13225	2	4.5 oz.	2400	11/32"	23 3/4"	2 3/4"	1 3/4"	22 3/4"	1 1/4"

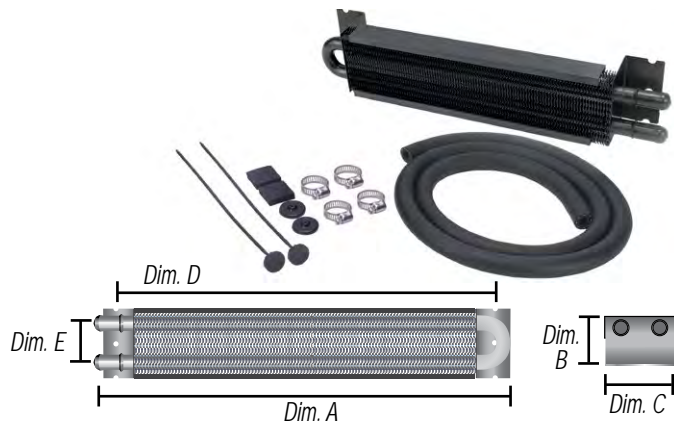

Part No.
13211

Power Steering Cooler Kits

- Extends pump & seal life
- Reduces heat-related pump failure
- 1/2" copper tubing expanded into aluminum cooling fins
- 11/32" hose barb inlets

Install Kit Only Part # 12006

Power Steering Kit Part No.	No. of Passes	Fluid Capacity	BTU	Inlet Size	Dim. A (Width)	Dim. B (Height)	Dim. C (Depth)	Dim. D (Mounting)	Dim. E (Inlet to Inlet)
13210	2	1.5 oz.	1500	11/32" Barb	8 1/8"	2 3/4"	1 3/4"	5 1/4"	1 1/4"
13211	2	2.5 oz.	2000	11/32" Barb	13 3/4"	2 3/4"	1 3/4"	11 3/4"	1 1/4"

Series 6000 Dyno-Cool Tube & Fin Fluid Cooler Kits



THE LEADER IN PERFORMANCE COOLING

Transmission Cooler Kits

Part No.
12903



- Prevents heat-related component failure & fluid breakdown
- 1/2" aluminum tubing expanded into aluminum cooling fins
- Embossed turbulators in each tube agitate fluid for maximum heat transfer
- 1 1/32" hose barb inlets
- Hardware kit includes high pressure/high temperature hose, Insta-Dapt radiator adapter with plastic rod mounting

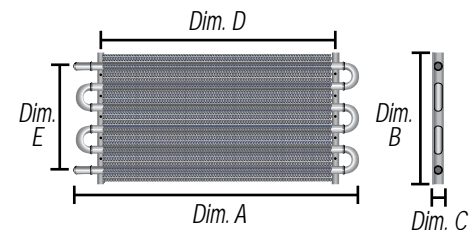

Install Kit Only Part # 12006

Trans Cooler Kit Part No.	No. of Passes	Fluid Capacity	GVW	BTU	Inlet Size	Dim. A (Width)	Dim. B (Height)	Dim. C (Depth)	Dim. D (Mounting)	Dim. E (Inlet to Inlet)
12901	4	3.25 oz.	12000	3300	11/32" Barb	12 3/4"	5"	3/4"	10 1/8"	3 3/4"
12902	4	4 oz.	14000	3300	11/32" Barb	15 1/4"	5"	3/4"	12 1/4"	3 3/4"
12903	6	7 oz.	18500	5000	11/32" Barb	15 1/4"	7 1/2"	3/4"	12 1/4"	6 1/4"
12904	8	11 oz.	20500	7000	11/32" Barb	15 1/4"	10"	3/4"	12 1/4"	8 3/4"
12906	6	6 oz.	15500	4700	11/32" Barb	12 3/4"	7 1/2"	3/4"	10 1/8"	6 1/4"
12907	8	6.5 oz.	18200	6600	11/32" Barb	12 3/4"	10"	3/4"	10 1/8"	8 3/4"

Part No.
12200



Power Steering Cooler Kits

- Extends pump & seal life
- Reduces heat-related pump failure
- All-aluminum cooler construction
- 11/32" hose barb inlets

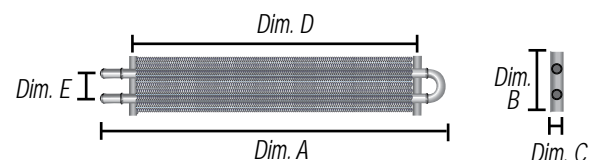

Install Kit Only Part # 12006

Power Steering Kit Part No.	No. of Passes	Fluid Capacity	BTU	Inlet Size	Dim. A (Width)	Dim. B (Height)	Dim. C (Depth)	Dim. D (Mounting)	Dim. E (Inlet to Inlet)
12213	2	1.5 oz.	1300	11/32" Barb	9 1/8"	2 1/2"	3/4"	8 3/4"	1 1/4"
12200	2	2 oz.	1300	11/32" Barb	12 3/4"	2 1/2"	3/4"	5 7/8"	1 1/4"



THE LEADER IN PERFORMANCE COOLING

Premium Heat Sink Fluid Coolers



Features and Benefits

- Increased fluid capacity
- Features internal and external heat dissipating fins
- Stamped Internal Turbulator for increased efficiency
- Removable brackets allow cooler to be clocked
- Compact 3" diameter fits most frame rails

Dimensions

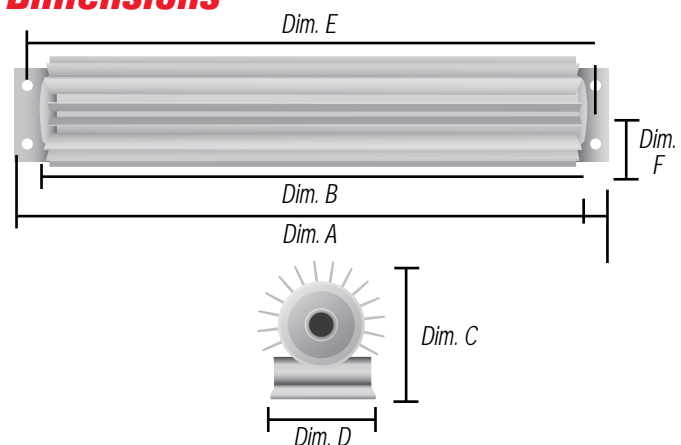

Internal fins absorb heat

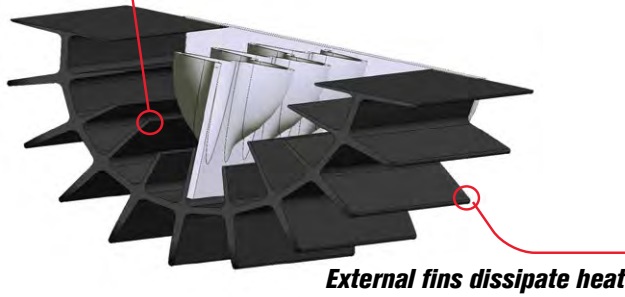

Increased Fluid Capacity

We have completely redesigned the extrusion to maximize efficiency, by increasing the cavity, we have increased the amount of fluid in the cooler.

Redesigned Heat Dissipating Fins

The redesigned fins allow for better heat dissipation, the internal fins are designed to pull the heat out of the passing fluid while transferring that heat out through the external fins.

Removable brackets allow cooler to be clocked

The removable brackets are a great addition to the heat sink lineup, they allow the cooler to be clocked in any mounting position desired.

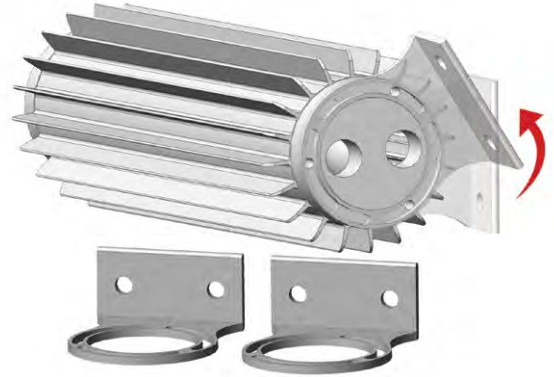

Now offered in Black Anodized finish

New for 2018 to 2019 we are introducing a full line-up of coolers with a black anodized finish, the single pass coolers come with a 1/2" NPT female inlets, while the dual pass coolers will be offered with 3/8" NPT inlets



Single Pass Black Anodized Models

- Black anodized finish
- Adjustable bracket design
- Fittings not included

COOLER ONLY

Single Pass Part No.	Inlet Size	Fluid Capacity	Dim A. (Overall Length)	Dim B. (Core Length)	Dim C. (Height)	Dim D. (Width)	Dim E. (Mounting)	Dim F. (Mounting)
13269	1/2" NPT	10 oz	10 1/4"	8 5/8"	3 1/4"	3"	9 5/8"	1 3/8"
13270	1/2" NPT	14 oz	14 1/4"	12 5/8"	3 1/4"	3"	13 5/8"	1 3/8"
13271	1/2" NPT	18 oz	17 1/4"	15 5/8"	3 1/4"	3"	16 5/8"	1 3/8"
13272	1/2" NPT	22 oz	20 1/4"	18 5/8"	3 1/4"	3"	19 5/8"	1 3/8"
13277	1/2" NPT	28 oz	25 1/4"	23 5/8"	3 1/4"	3"	24 5/8"	1 3/8"



Dual Pass Black Anodized Models

- Black anodized finish
- Adjustable bracket design
- Fittings not included

COOLER ONLY

Dual Pass Part No.	Inlet Size	Fluid Capacity	Dim A. (Overall Length)	Dim B. (Core Length)	Dim C. (Height)	Dim D. (Width)	Dim E. (Mounting)	Dim F. (Mounting)
13279	3/8" NPT	10 oz	10 1/4"	8 5/8"	3 1/4"	3"	9 5/8"	1 3/8"
13280	3/8" NPT	14 oz	14 1/4"	12 5/8"	3 1/4"	3"	13 5/8"	1 3/8"
13281	3/8" NPT	18 oz	17 1/4"	15 5/8"	3 1/4"	3"	16 5/8"	1 3/8"
13282	3/8" NPT	22 oz	20 1/4"	18 5/8"	3 1/4"	3"	19 5/8"	1 3/8"
13287	3/8" NPT	28 oz	25 1/4"	23 5/8"	3 1/4"	3"	24 5/8"	1 3/8"



Clear Anodized Models

- Clear anodized finish - Black anodized brackets
- Available in single pass or dual pass
- Single Pass – 1/2" NPT, Dual Pass – 3/8" NPT
- Hardware kit includes aluminum hose barbs fittings

Single Pass Part No.	Inlet Size	Dual Pass Part No.	Inlet Size	Fluid Capacity	Dim A. (Overall Length)	Dim B. (Core Length)	Dim C. (Height)	Dim D. (Width)	Dim E. (Mounting)	Dim F. (Mounting)
13249	1/2" NPT	13259	3/8" NPT	10 oz	10 1/4"	8 5/8"	3 1/4"	3"	9 5/8"	1 3/8"
13250	1/2" NPT	13260	3/8" NPT	14 oz	14 1/4"	12 5/8"	3 1/4"	3"	13 5/8"	1 3/8"
13251	1/2" NPT	13261	3/8" NPT	18 oz	17 1/4"	15 5/8"	3 1/4"	3"	16 5/8"	1 3/8"
13252	1/2" NPT	13262	3/8" NPT	22 oz	20 1/4"	18 5/8"	3 1/4"	3"	19 5/8"	1 3/8"
13257	1/2" NPT	13267	3/8" NPT	28 oz	25 1/4"	23 5/8"	3 1/4"	3"	24 5/8"	1 3/8"



Transmission Cooler Kits

- Clear anodized finish - Black anodized brackets
- Extends transmission service life by preventing heat-related component failure & fluid breakdown
- Available in single pass or dual pass
- Transmission cooler kit includes high pressure/high temperature hose, Insta-Dapt radiator adapter, hose barbs fittings and mounting hardware

Single Pass Part No.	Inlet Size	Dual Pass Part No.	Inlet Size	Fluid Capacity	Dim A. (Overall Length)	Dim B. (Core Length)	Dim C. (Height)	Dim D. (Width)	Dim E. (Mounting)	Dim F. (Mounting)
13253	1/2" NPT	13263	3/8" NPT	14 oz	14 1/4"	12 5/8"	3 1/4"	3"	13 5/8"	1 3/8"
13254	1/2" NPT	13264	3/8" NPT	18 oz	17 1/4"	15 5/8"	3 1/4"	3"	16 5/8"	1 3/8"
13255	1/2" NPT	13265	3/8" NPT	22 oz	20 1/4"	18 5/8"	3 1/4"	3"	19 5/8"	1 3/8"
13256	1/2" NPT	13266	3/8" NPT	28 oz	25 1/4"	23 5/8"	3 1/4"	3"	24 5/8"	1 3/8"



Power Steering Cooler Kit

- Clear anodized finish - Black anodized brackets
- Extends power steering service life by preventing heat-related component failure & fluid breakdown
- Improves power steering performance
- Power steering cooler kit includes high pressure/high temperature hose, fittings and mounting hardware

Single Pass Part No.	Inlet Size	Fluid Capacity	Dim A. (Overall Length)	Dim B. (Core Length)	Dim C. (Height)	Dim D. (Width)	Dim E. (Mounting)	Dim F. (Mounting)
13349	1/2" NPT	10 oz	10 1/4"	8 5/8"	3 1/4"	3"	9 5/8"	1 3/8"
13350	1/2" NPT	14 oz	14 1/4"	12 5/8"	3 1/4"	3"	13 5/8"	1 3/8"

Radiator Cooling Fittings



Barbed Splicer Fittings

Dodge / Jeep Radiator Adapter

Fits 1960-1997 Dodge Trucks with rubber transmission lines
Fits 1983-2012 Jeep with 5.2L, 4.2L, 4.0L, 2.5L Engines with rubber transmission lines

Part No.	13028
----------	-------



1/2" Inverted Flare Fittings

Ford / Lincoln / Mercury Radiator Adapter

Fits 1983-2007 Ford/Lincoln/Mercury Cars, Trucks, Blackwood, Bronco, Expedition, Navigator, Ranger, Vans with 7.3L, 6.9L, 5.8L, 5.0L, 4.9L, 4.6L, 4.2L, 2.9L, 2.8L, 2.3L Engines

Part No.	13024
----------	-------



9/16" - 18 37° JIC Fittings

Dodge Dakota Radiator Adapter

Fits 1999-2005 Dodge Dakota

Part No.	13030
----------	-------



9/16" - 24 45° SAE Male & Female Fittings

Dodge Radiator Adapter

Fits 1999-2003 Dodge Trucks, Vans with 5.9L, 5.2L, 3.9L Engines

Part No.	13034
----------	-------



5/8" Inverted Flare Fittings

GM Radiator Adapter

Fits 1981-2000 Buick w/ 5.7L, 3.8L, 3.3L, 3.1L, 2.5L, 2.4L, 2.3L, 2.2L Engines

Fits 1988-2007 Cadillac Cars, Trucks with 6.2L, 6.0L, 5.7L, 5.3L, 4.9L, 4.6L, 4.5L, 4.1L, 3.0L Engines

Fits 1987-2012 Chevrolet Cars, SUV's, Chevrolet, GM Trucks, Vans w/ 8.1L, 7.4L, 6.5L, 6.0L, 5.7L, 5.3L, 5.0L, 4.8L, 4.3L, 3.8L, 3.4L, 3.2L, 2.4L, 2.3L, 2.2L Engines

Fits 1996-2001 Oldsmobile Bravada with 4.3L Engine

Fits 1983-2005 Pontiac Cars, SUV's with 5.7L, 5.0L, 3.8L, 3.4L, 3.1L, 2.4L, 2.2L, 1.6L Engines

Part No.	13018
----------	-------



1/4" NPT M/F 3/8" NPT Male Fittings

Ford / Mercury Radiator Adapter

Fits 1983-2012 Ford/Mercury Cars, Trucks, Bronco, Expedition, Ranger, Vans w/ 7.5L, 7.3L, 6.9L, 6.6L, 5.8L, 5.4L, 5.0L, 4.9L, 4.7L, 4.6L, 4.2L, 4.0L, 3.8L, 3.0L, 2.9L, 2.8L, 2.5L, 2.3L Engines

Fits 1983-2007 Mercury Cars w/ 5.8L, 5.0L, 4.6L, 3.8L, 3.0L, 2.5L, 2.3L Engines

Part No.	13014
----------	-------



5/8" Inverted Flare Fittings

Ford / Lincoln Trucks & SUV's Radiator Adapter

Fits 1998-2012 Ford/Lincoln Trucks & SUV's, Blackwood, Excursion, Expedition, Explorer, Navigator, Ranger with 7.3L, 6.9L, 6.8L, 5.4L, 5.0L, 4.6L, 4.0L, 3.0L, 2.5L Engines

Part No.	13025
----------	-------



Snap in Tube Fitting

GM Radiator Adapter

Fits 1993-2012 Buick with 4.6L, 4.2L, 3.9L, 3.8L, 3.6L, 3.5L, 3.4L, 3.3L, 3.1L, 2.5L, 2.4L, 2.3L, 2.2L Engines

Fits 1993-2012 Cadillac 6.2L, 6.0L, 5.7L, 5.3L, 4.9L, 4.6L, 4.5L, 4.1L, 3.0L Engines

Fits 2000-2012 Chevrolet Cars, SUV's, Chevrolet, GM Trucks, Vans with 3.8L, 3.4L, 6.0L, 5.3L, 4.8L, 4.3L, 4.2L, 3.7L, 3.5L, 3.4L, 2.9L, 2.8L Engines

Fits 2003-2007 Isuzu SUV's with 4.2L, 5.3L Engines

Fits 2002-2004 Oldsmobile Bravada with 4.2L Engine

Fits 2001-2007 Pontiac with 3.9L, 3.8L, 3.5L, 3.4L, 3.1L Engines

Part No.	13035
----------	-------

Universal Transmission Line Fittings



5/16" Transmission Cooler Line to 3/8" NPT Hose Barb

Part No.	13031
----------	-------



3/8" Transmission Cooler Line to 3/8" NPT Hose Barb

Part No.	13032
----------	-------



1/2" Transmission Cooler Line to 1/2" NPT Hose Barb

Part No.	13033
----------	-------



Fits most vehicles with 5/16" transmission lines. Includes male and female threads.

Part No.	13004
----------	-------

Ram Air Fluid Coolers - Quick Guide

Ram Air Cooler Kits							
Size	Part No.	Series	Description	Width	Height	Depth	Page
8" to 9" Width	13309	7000 Tube & Fin Cooler	-6 AN, 4 Pass	8 1/8"	5"	3/4"	29
	13310	7000 Tube & Fin Cooler	-6 AN, 2 Pass	8 1/8"	2 5/8"	1 3/4"	29
10" to 15" Width	33601	9000 Plate & Fin Cooler	1/2" NPT, 5 Row	9 3/4"	4 1/8"	1 1/4"	25
	33602	9000 Plate & Fin Cooler	1/2" NPT, 9 Row	9 3/4"	6 1/4"	1 1/4"	25
	33603	9000 Plate & Fin Cooler	1/2" NPT, 13 Row	9 3/4"	8 7/16"	1 1/4"	25
	33604	9000 Plate & Fin Cooler	1/2" NPT, 17 Row	9 3/4"	10 5/8"	1 1/4"	25
	NEW 13605	9000 Tube & Fin Cooler	1/2" NPT, 21 Row	9 3/4"	12 13/16"	1 1/4"	25
	33501	8000 Plate & Fin Cooler	11/32" Barb, 9 Row	11"	5 3/4"	7/8"	27
	33502	8000 Plate & Fin Cooler	11/32" Barb, 13 Row	11"	7 1/4"	7/8"	27
	33503	8000 Plate & Fin Cooler	11/32" Barb, 18 Row	11"	9 1/4"	7/8"	27
	33504	8000 Plate & Fin Cooler	11/32" Barb, 24 Row	11"	12"	7/8"	27
	NEW 33523	8000 Plate & Fin Cooler	1/2"-20 Inverted Flare, 18 Row	11"	8 13/16"	7/8"	27
	13322	7000 Tube & Fin Cooler	(2) 11/32", (2) 1/2" Barb, 4 pass and 4 pass	12 13/16"	10 1/4"	3/4"	32
	51006	10000 Stack Plate Cooler	-6 AN, 10 Row	13"	4 7/16"	2"	21
	51008	10000 Stack Plate Cooler	-8 AN, 10 Row	13"	4 9/16"	2"	21
	51010	10000 Stack Plate Cooler	-10 AN, 10 Row	13"	4 11/16"	2"	21
	51078	10000 Stack Plate Cooler	No Fittings, 10 Row	13"	4"	2"	21
	51606	10000 Stack Plate Cooler	-6 AN, 16 Row	13"	6 7/16"	2"	21
	51608	10000 Stack Plate Cooler	-8 AN, 16 Row	13"	6 9/16"	2"	21
	51610	10000 Stack Plate Cooler	-10 AN, 16 Row	13"	6 11/16"	2"	21
	51678	10000 Stack Plate Cooler	No Fittings, 16 Row	13"	6"	2"	21
	51906	10000 Stack Plate Cooler	-6 AN, 19 Row	13"	7 5/16"	2"	21
	51908	10000 Stack Plate Cooler	-8 AN, 19 Row	13"	7 7/16"	2"	21
	51910	10000 Stack Plate Cooler	-10 AN, 19 Row	13"	7 9/16"	2"	21
	51978	10000 Stack Plate Cooler	No Fittings, 19 Row	13"	7"	2"	21
	52506	10000 Stack Plate Cooler	-6 AN, 25 Row	13"	9 3/16"	2"	21
	52508	10000 Stack Plate Cooler	-8 AN, 25 Row	13"	9 5/16"	2"	21
	52510	10000 Stack Plate Cooler	-10 AN, 25 Row	13"	9 9/16"	2"	21
	52578	10000 Stack Plate Cooler	No Fittings, 25 Row	13"	9"	2"	21
	53406	10000 Stack Plate Cooler	-6 AN, 34 Row	13"	11 13/16"	2"	21
	53408	10000 Stack Plate Cooler	-8 AN, 34 Row	13"	11 7/8"	2"	21
	53410	10000 Stack Plate Cooler	-10 AN, 34 Row	13"	12 1/16"	2"	21
	53478	10000 Stack Plate Cooler	No Fittings, 34 Row	13"	11"	2"	21
	54006	10000 Stack Plate Cooler	-6 AN, 40 Row	13"	13 11/16"	2"	21
	54008	10000 Stack Plate Cooler	-8 AN, 40 Row	13"	13 3/4"	2"	21
54010	10000 Stack Plate Cooler	-10 AN, 40 Row	13"	13 7/8"	2"	21	
54078	10000 Stack Plate Cooler	No Fittings, 40 Row	13"	13"	2"	21	
13311	7000 Tube & Fin Cooler	-6 AN, 4 Pass	13 1/2"	5 1/8"	3/4"	29	
13316	7000 Tube & Fin Cooler	6 Pass	13 1/2"	7 5/8"	3/4"	29	
13317	7000 Tube & Fin Cooler	-6 AN, 8 Pass	13 1/2"	10 1/4"	3/4"	29	
13318	7000 Tube & Fin Cooler	-6 AN, 10 Pass	13 1/2"	12 5/8"	3/4"	29	
13223	7000 Tube & Fin Cooler	-6 AN, 2 Pass (Frame Rail Cooler)	13 3/4"	2 1/2"	1 3/4"	32	
15301	7000 Tube & Fin Cooler	-8 AN, 8 pass and 8 pass	13 15/16"	10 1/2"	1 3/4"	29	
15321	7000 Tube & Fin Cooler	-8 AN, 4 pass and 4 pass	13 15/16"	10 1/4"	3/4"	29	
15331	7000 Tube & Fin Cooler	-8 AN, 4 pass and 2 pass	13 15/16"	7 5/8"	3/4"	29	
16" to 25" Width	13302	7000 Tube & Fin Cooler	(2) 11/32", (2) 1/2" Barb, 6 pass and 4 pass	16 15/16"	12 5/8"	3/4"	29
	13312	7000 Tube & Fin Cooler	-6 AN, 4 Pass	17 1/2"	5 1/8"	3/4"	29
	13313	7000 Tube & Fin Cooler	-6 AN, 6 Pass	17 1/2"	7 5/8"	3/4"	29
	13314	7000 Tube & Fin Cooler	-6 AN, 8 Pass	17 1/2"	10 1/4"	3/4"	29
	13315	7000 Tube & Fin Cooler	-6 AN, 10 Pass	17 1/2"	12 5/8"	3/4"	29
	13221	7000 Tube & Fin Cooler	-6 AN, 2 Pass (Frame Rail Cooler)	17 3/4"	2 1/2"	1 3/4"	32
	33633	9500 Plate & Fin Cooler	5/8" Inverted Flare, 13 Row	22 3/4"	9 1/4"	1 1/4"	19
	NEW 13225	7000 Tube & Fin Cooler	-6 AN, 2 Pass (Frame Rail Cooler)	24 3/4"	2 1/2"	1 3/4"	32

Ram Air Fluid Coolers - Quick Guide (continued)

Ram Air Coolers - Transmission Oil Cooler Kits							
Size	Part No.	Series	Description	Width	Height	Depth	Page
10" to 15" Width	13611	9000 Tube & Fin Cooler	1/2" NPT, 5 Row	9 3/4"	4 1/8"	1 1/4"	25
	13612	9000 Tube & Fin Cooler	1/2" NPT, 9 Row	9 3/4"	6 1/4"	1 1/4"	25
	13613	9000 Tube & Fin Cooler	1/2" NPT, 13 Row	9 3/4"	8 7/16"	1 1/4"	25
	13614	9000 Tube & Fin Cooler	1/2" NPT, 17 Row	9 3/4"	10 5/8"	1 1/4"	25
	NEW 13615	9000 Tube & Fin Cooler	1/2" NPT, 21 Row	9 3/4"	12 13/16"	1 1/4"	25
	13501	8000 Tube & Fin Cooler	11/32" Barb, 9 Row	11"	5 3/4"	7/8"	27
	13502	8000 Tube & Fin Cooler	11/32" Barb, 13 Row	11"	7 1/4"	7/8"	27
	13503	8000 Tube & Fin Cooler	11/32" Barb, 18 Row	11"	9 1/4"	7/8"	27
	13504	8000 Tube & Fin Cooler	11/32" Barb, 24 Row	11"	12"	7/8"	27
	NEW 13523	8000 Tube & Fin Cooler	1/2"-20 Inverted Flare, 18 Row	11"	8 13/16"	7/8"	27
	13401	10000 Stack Plate Cooler	-6 AN, 10 Row	13"	4 7/16"	2"	22
	12901	6000 Tube & Fin Cooler	11/32" Barb, 4 Pass	12 3/4"	5"	3/4"	33
	13402	10000 Stack Plate Cooler	-6 AN, 16 Row	13"	6 7/16"	2"	22
	13403	10000 Stack Plate Cooler	-6 AN, 19 Row	13"	7 5/16"	2"	22
	12906	6000 Tube & Fin Cooler	11/32" Barb, 6 Pass	12 3/4"	7 1/2"	3/4"	33
	12907	6000 Tube & Fin Cooler	11/32" Barb, 8 Pass	12 3/4"	10"	3/4"	33
	13101	7000 Tube & Fin Cooler	11/32" Barb, 4 Pass	13 1/2"	5 1/8"	3/4"	30
	13306	7000 Tube & Fin Cooler	-6 AN, 6 Pass	13 1/2"	7 5/8"	3/4"	30
	13106	7000 Tube & Fin Cooler	11/32" Barb, 6 Pass	13 1/2"	7 5/8"	3/4"	30
	13107	7000 Tube & Fin Cooler	11/32" Barb, 8 Pass	13 1/2"	10 1/4"	3/4"	30
	13108	7000 Tube & Fin Cooler	11/32" Barb, 10 Pass	13 1/2"	12 5/8"	3/4"	30
	13222	7000 Tube & Fin Cooler	11/32" Barb, 2 Pass (Frame Rail Cooler)	13 3/4"	2 1/2"	1 3/4"	32
	12902	6000 Tube & Fin Cooler	11/32" Barb, 4 Pass	15 1/4"	5"	3/4"	33
	12903	6000 Tube & Fin Cooler	11/32" Barb, 6 Pass	15 1/4"	7 1/2"	3/4"	33
12904	6000 Tube & Fin Cooler	11/32" Barb, 8 Pass	15 1/4"	10"	3/4"	33	
16" to 25" Width	13102	7000 Tube & Fin Cooler	11/32" Barb, 4 Pass	17 1/2"	5 1/8"	3/4"	30
	13103	7000 Tube & Fin Cooler	11/32" Barb, 6 Pass	17 1/2"	7 5/8"	3/4"	30
	13303	7000 Tube & Fin Cooler	-6 AN, 6 Pass	17 1/2"	7 5/8"	3/4"	30
	13104	7000 Tube & Fin Cooler	11/32" Barb, 8 Pass	17 1/2"	10 1/4"	3/4"	30
	13304	7000 Tube & Fin Cooler	-6 AN, 8 Pass	17 1/2"	10 1/4"	3/4"	30
	13105	7000 Tube & Fin Cooler	11/32" Barb, 10 Pass	17 1/2"	12 5/8"	3/4"	30
	13220	7000 Tube & Fin Cooler	11/32" Barb, 2 Pass (Frame Rail Cooler)	17 3/4"	2 1/2"	1 3/4"	32
	NEW 13633	9500 Plate & Fin Cooler	5/8" Inverted Flare, 13 Row	22 3/4"	9 1/4"	1 1/4"	21
	13224	7000 Tube & Fin Cooler	11/32" Barb, 2 Pass (Frame Rail Cooler)	24 3/4"	2 1/2"	1 3/4"	30

Ram Air Coolers - Engine Oil Cooler Kits							
Size	Part No.	Series	Description	Width	Height	Depth	Page
10" to 15" Width	15405	9000 Tube & Fin Cooler	13 Row, Sandwich Adapter	10 1/8"	8 7/8"	1 1/4"	25
	15451	9000 Tube & Fin Cooler	13 Row, Spin-On Adapter	10 1/8"	8 7/8"	1 1/4"	25
	15602	10000 Stack Plate Cooler	10 Row, Sandwich Adapter	13"	4 9/16"	2"	22
	15603	10000 Stack Plate Cooler	10 Row, Sandwich Adapter	13"	4 9/16"	2"	22
	15604	10000 Stack Plate Cooler	10 Row, Sandwich Adapter	13"	4 9/16"	2"	22
	15605	10000 Stack Plate Cooler	10 Row, Sandwich Adapter	13"	4 9/16"	2"	22
	15651	10000 Stack Plate Cooler	10 Row, Spin-On Adapter	13"	4 9/16"	2"	22
16" to 25" Width	15502	7000 Tube & Fin Cooler	11 1/32" Barb, 6 Pass, Sandwich Adapter	16 5/8"	7 5/8"	3/4"	31
	15503	7000 Tube & Fin Cooler	11 1/32" Barb, 6 Pass, Sandwich Adapter	16 5/8"	7 5/8"	3/4"	31
	15505	7000 Tube & Fin Cooler	11 1/32" Barb, 6 Pass, Sandwich Adapter	16 5/8"	7 5/8"	3/4"	31
	15551	7000 Tube & Fin Cooler	11 1/32" Barb, 6 Pass, Spin-On Adapter	16 5/8"	7 5/8"	3/4"	31

Ram Air Coolers - Power Steering Kits							
Size	Part No.	Series	Description	Width	Height	Depth	Page
8" to 9" Width	13210	7000 Tube & Fin Cooler	11/32" Barb, 2 Pass (Frame Rail Cooler)	8 1/8"	1 3/4"	1 3/4"	32
	13212	7000 Tube & Fin Cooler	11/32" Barb, 4 Pass	8 1/8"	5 1/8"	3/4"	31
	13213	7000 Tube & Fin Cooler	11/32" Barb, 2 Pass	8 1/8"	2 5/8"	3/4"	31
	12213	6000 Tube & Fin Cooler	11/32" Barb, 2 Pass	9 1/8"	2 1/2"	3/4"	33
10" to 15" Width	13215	8000 Plate & Fin Cooler	11/32" Barb, 9 Row	11"	5 3/4"	7/8"	27
	12200	6000 Tube & Fin Cooler	11/32" Barb, 2 Pass	12 3/4"	2 1/2"	3/4"	33
	13200	7000 Tube & Fin Cooler	11/32" Barb, 2 Pass	12 3/4"	2 5/8"	3/4"	31
	13211	7000 Tube & Fin Cooler	11/32" Barb, 2 Pass (Frame Rail Cooler)	13 3/4"	1 3/4"	1 3/4"	32



THE LEADER IN PERFORMANCE COOLING

Black Anodized Aluminum Fittings

Female AN Swivel Hose Barb Fittings



Part No.	Description	U/M
98200	-6 AN Female x 3/8" Hose Barb	Ea.
98201	-8 AN Female x 3/8" Hose Barb	Ea.
98202	-8 AN Female x 1/2" Hose Barb	Ea.
98203	-10 AN Female x 1/2" Hose Barb	Ea.

Male AN Hose Barb Fittings



Part No.	Description	U/M
98204	-6 AN Male x 3/8" Hose Barb	Ea.
98205	-8 AN Male x 1/2" Hose Barb	Ea.

7/8-14 O-Ring to Hose Barb Fittings



Part No.	Description	U/M
98206	7/8 -14 UNF Male o-ring x 3/8" Hose Barb	Ea.
98208	7/8 -14 UNF Male o-ring x 1/2" Hose Barb	Ea.

Straight NPT Hose Barb Fittings



Part No.	Description	U/M
98100	1/4" NPT Male x 3/8" Hose Barb	Ea.
98101	3/8" NPT Male x 3/8" Hose Barb	Ea.
98102	3/8" NPT Male x 1/2" Hose Barb	Ea.
98103	1/2" NPT Male x 1/2" Hose Barb	Ea.

Male Adapter Fittings-AN x 7/8-14 O-ring



Part No.	Description	U/M
59006	-6 AN Male x 7/8"-14 UNF o-ring	Ea.
59008	-8 AN Male x 7/8"-14 UNF o-ring	Ea.
59010	-10 AN Male x 7/8"-14 UNF o-ring	Ea.
59012	-12 AN Male x 7/8"-14 UNF o-ring	Ea.
59106	-6 AN x 5/8"-18 o-ring	Ea.
59108	-8 AN x 5/8"-18 o-ring	Ea.

Male Adapter Fittings-AN x NPT



Part No.	Description	U/M
59206	-6AN Male x 3/8" NPT Male	Ea.
59208	-8AN Male x 3/8" NPT Male	Ea.
59210	-10AN Male x 3/8" NPT Male	Ea.
59306	-6AN Male x 1/2" NPT Male	Ea.
59308	-8AN Male x 1/2" NPT Male	Ea.
59310	-10AN Male x 1/2" NPT Male	Ea.

- 6061 aluminum
- Black anodized finish

Male AN Hose Barb Fittings



Part No.	Description	U/M
35799	-10 AN UNF o-ring x -10 AN UNF o-ring Coupler Fitting	Ea.

90° Swivel Fittings



Part No.	Description	U/M
59506	7/8 -14 UNF o-ring to -6 AN male 90° swivel	Ea.
59508	7/8 -14 UNF o-ring to -8 AN male 90° swivel	Ea.
59510	7/8-14 UNF o-ring to -10 AN male 90° swivel	Ea.

90° Swivel Fittings



59406	7/8-14 UNF o-ring to 3/8" hose barb male 90° swivel	Ea.
59408	7/8-14 UNF o-ring to 1/2" hose barb male 90° swivel	Ea.

90° Swivel Fittings



59606	3/8" NPT to AN6 male 90° swivel	Ea.
59608	3/8" NPT to AN8 male 90° swivel	Ea.
59706	1/2" NPT to AN6 male 90° swivel	Ea.
59708	1/2" NPT to AN8 male 90° swivel	Ea.

AN Swivel Fittings with 1/8" Port



Part No.	Description	U/M
35920	-6 AN Male x -6 AN Female Swivel	Ea.
35921	-8 AN Male x -8 AN Female Swivel	Ea.
35922	-10 AN Male x -10 AN Female Swivel	Ea.

Compression Fittings-Tube to AN



Part No.	Description	U/M
13044	Compression Fitting 5/16" Tube to -6AN Male	Ea.
13045	Compression Fitting 3/8" Tube to -6AN Male	Ea.
13046	Compression Fitting 1/2" Tube to -8AN Male	Ea.

Compression Fittings-Tube to Hose Barb



Part No.	Description	U/M
13041	Compression Fitting 5/16" Tube to 3/8" Hose Barb	Ea.
13042	Compression Fitting 3/8" Tube to 3/8" Hose Barb	Ea.
13043	Compression Fitting 1/2" Tube to 1/2" Hose Barb	Ea.



THE LEADER IN PERFORMANCE COOLING



1962 Chevrolet Impala SS "THE RELIC" ***Owner/Builder: Dale Snoke***

Derale Engine Oil Cooling: Oil Sandwich Adapter, Fluid Control Thermostat and Dual Stack Plate Oil Coolers with Aluminum Brackets

Derale Radiator Cooling: Heavy Duty Stainless Steel 17" Flex Fan and Fan Spacer

- **Original Chevrolet 409 SS Vehicle with 30,000 original miles**
- **385ci Chevrolet Race Motor with 535 Horsepower and 510 ft/lbs Torque**
- **T-10 Four Speed Transmission**
- **Currie 9-inch 3:70 gear**
- **Wilwood Disc Brakes**
- **Global West Suspension/Boxed Lower Control Arms (Vintage Track Day Set-Up)**
- **Doug's Headers/Custom Stainless Exhaust System**
- **Pertronix Ignition System**
- **So-Cal Speed Shop Instruments**

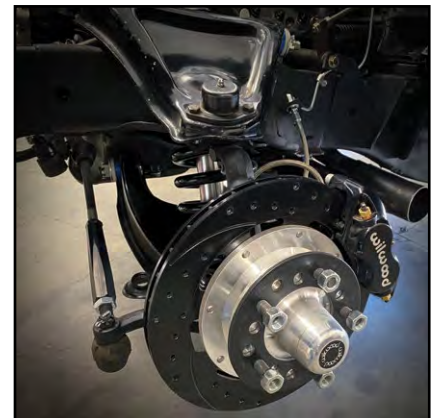



“THE RELIC” 1962 CHEVROLET IMPALA SS

DALE SNOKE

PHOTO: COBY GEWERTZ



THE LEADER IN PERFORMANCE COOLING



THE LEADER IN PERFORMANCE COOLING

2020 WINNER - International "RAT-ical Rod" Build-Off



2020 Derale
"Cool-Ride" Trophy

2020 Custom Built Truck Owner/Builder: Sean Puz

- Engine Oil Cooling:** P/N 65840 – Hi-Flow Racing Remote Fluid Cooler (-8AN Fittings)
P/N 35021 – 180°F Inline Fan Control
- Oil Filter Mount:** P/N 35709 – Premium Series Remote Filter Mount
- Trans Cooling:** P/N 65840 – Hi-Flow Racing Remote Fluid Cooler (-6AN Fittings)
P/N 35020 – 180°F Inline Fan Control
- Power Steering:** P/N 13279 – Black Anodized Heat Sink Cooler
- Radiator:** Custom Built Radiator Using Four P/N 61178 – Hi-Flow Racing Coolers
- Radiator Fans:** Custom Built Radiator Shroud Using P/N 16924 – High-Output Drop-In Electric Fans (Qty. 2)
- Fan Control:** P/N 16795 – PWM Electric Fan Controller
- Fuel Pump:** P/N 72000 – Performance Inline Fuel Pump

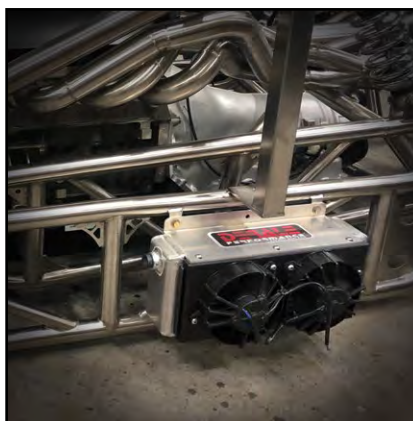
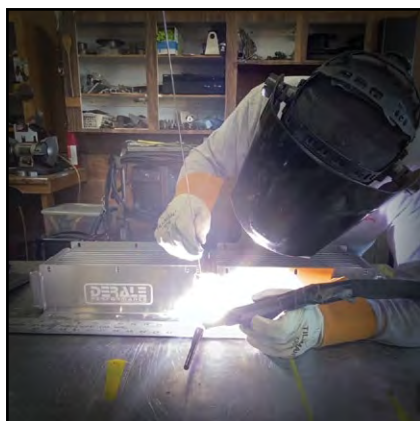

Hose & Install Kits

Transmission Cooler Installation Kits



THE LEADER IN PERFORMANCE COOLING

- Complete installation kit for mounting most transmission coolers with 5/16" cooler lines



Part # 13064 - Rigid Cooler Remount kit - 8ft. 11/32 Hose



Part # 12006 - Standard Cooler Remount kit - 4ft. 11/32 Hose



Part # 13006 - Deluxe Cooler Remount kit - 4ft. 11/32 Hose



Part # 13065 - Deluxe Cooler Remount kit - 4ft. 11/32 Hose with -6 AN Fittings

Replacement Hose

- Transmission or engine oil hose
- High temperature OEM spec hose
- 300 p.s.i. burst rating



Part # 13003

Part # 13007

Part No.	Hose ID	Length	Application
13003	11/32"	4 ft.	Transmission
13007	11/32"	25 ft.	Transmission
13016	3/8"	5 ft.	Transmission
13017	3/8"	25 ft.	Transmission
15700	1/2"	10 ft.	Engine
15701	1/2"	5 ft.	Engine
15740	1/2"	8 ft.	Engine
15799	1/2"	25 ft.	Engine

Insta-Mount Kit

- Universal mounting kit for coolers & electric fans



Part # 13001

Rigid Mount Kit

- 4 3/4" universal bendable metal mounting brackets



Part # 13002

Rigid Mount Kit

- Universal bendable mounting brackets with hardware
PN: 13062 4 3/4" Brackets
PN: 13063 10" Brackets

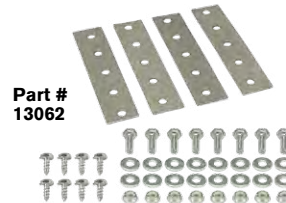

Part # 13062

Hose Clamps

- Universal hose clamps
- Fit from 5/16-1/2" hose



Part # 13008

Engine Oil Cooler Installation Kit

- Complete engine oil cooler installation kit
- Universal design to fit most automotive applications



Part # 15751

Remote Engine Oil Cooler Installation Kit

- Complete kit to install a remote mount engine oil cooler
- Universal design to fit most automotive applications



Part # 15752



THE LEADER IN PERFORMANCE COOLING

Engine Oil Filter Relocation Kits



Features and Benefits

- Allows oil filter to be moved to a more convenient location
- Faster and easier filter changes
- Ideal for engine swaps
- Increases oil capacity
- Cast from high quality aluminum
- 10' length of 1/2" OEM-spec hose included
- Filter mount uses Fram PH8A or equivalent
- Complete hardware kit included

Filter Mount - Ports Up

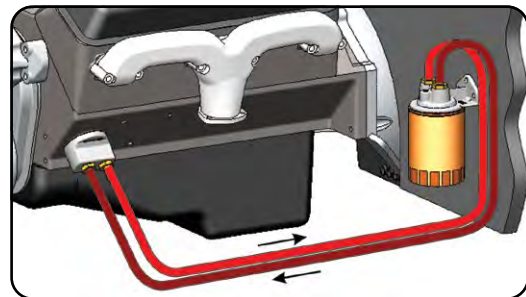

Filter Mount - Side Ports

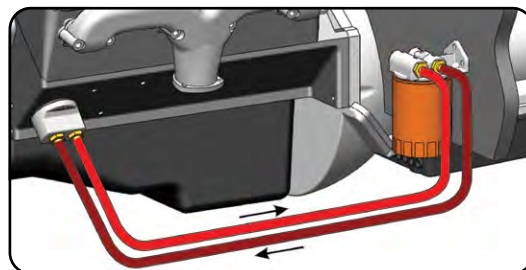

Filtration Kits

Spin-On Adapter - Ports Up Filter Mount - Ports Up



Part No.
15715

Spin-On Adapter - Ports Up (Universal) Filter Mount - Ports Up



Part No.
15748

Part No.	Engine Thread Size	Filter Thread Size	Filter Landing	Inlet/Outlet Ports
Single Mount - Ports Up				
15715	3/4"-16	3/4"-16	2 1/2", 2 3/4"	1/2" NPT
15716	13/16"-16	3/4"-16	2 1/2", 2 3/4"	1/2" NPT
15717	18 x 1.5mm	3/4"-16	2 1/2", 2 3/4"	1/2" NPT
15718	20 x 1.5mm	3/4"-16	2 1/2", 2 3/4"	1/2" NPT
15725	22 x 1.5mm	3/4"-16	2 1/2", 2 3/4"	1/2" NPT
15748	3/4"-16, 13/16"-16, 18 x 1.5mm, 20 x 1.5mm, 22 x 1.5mm	3/4"-16	2 1/2", 2 3/4"	1/2" NPT

Spin-On Adapter - Ports Up Filter Mount - Side Ports



Part No.
15781

Spin-On Adapter - Side Ports (Universal) Filter Mount - Side Ports



Part No.
15780

Part No.	Engine Thread Size	Filter Thread Size	Filter Landing	Inlet/Outlet Ports
Single Mount - Ports Up				
15781	3/4"-16	3/4"-16	2 1/2", 2 3/4"	1/2" NPT
Single Mount - Side Ports				
15780	3/4"-16, 13/16"-16, 18 x 1.5mm, 20 x 1.5mm, 22 x 1.5mm	3/4"-16	2 1/2", 2 3/4"	1/2" NPT

Spin-On Adapter - Ports Up (Universal) Dual Filter Mounts - Side Ports



Part No.
15749

Dual Mount - Side Ports				
Part No.	Engine Thread Size	Filter Thread Size	Filter Landing	Inlet/Outlet Ports
15749	3/4"-16, 13/16"-16, 18 x 1.5mm, 20 x 1.5mm, 22 x 1.5mm	3/4"-16	2 1/2", 2 3/4"	1/2" NPT



THE LEADER IN PERFORMANCE COOLING

Remote Filter Mount Kits



Reverse
FLOW DESIGN



Premium Series Filter Mounts

- Cast aluminum Billet-look
- Can be rotated 180° to reverse flow directions
- Designed to fit 2 1/2" to 3 1/2" oil filter
- Removable 3 hole mounting bracket
- Black powder coated finish
- -10 AN / 7/8"-14 O-Ring ports



Part No.
35708



Part No.
35709



Part No.
35707

Premium Series Single Filter Mounts - Ports Up

Ports Up Part No.	Filter Thread Size	Filter Landing	Inlet/Outlet Ports
35708	3/4"-16	2 1/2" to 3 1/2"	-10 AN / 7/8"-14 o-ring
35728	13/16"-16	2 1/2" to 3 1/2"	-10 AN / 7/8"-14 o-ring

Premium Series Single Filter Mounts - Side Ports

Side Ports Part No.	Filter Thread Size	Filter Landing	Inlet/Outlet Ports
35709	3/4"-16	2 1/2" to 3 1/2"	-10 AN / 7/8"-14 o-ring
35729	13/16"-16	2 1/2" to 3 1/2"	-10 AN / 7/8"-14 o-ring

Premium Series Dual Filter Mounts - Side Ports

Side Ports Part No.	Filter Thread Size	Filter Landing	Inlet/Outlet Ports
35707	3/4"-16	2 1/2" to 3 1/2"	-10 AN / 7/8"-14 o-ring
35727	13/16"-16	2 1/2" to 3 1/2"	-10 AN / 7/8"-14 o-ring
35799	-10 AN o-ring x -10 AN o-ring Coupler Fitting		



Standard Series Filter Mounts

- Cast aluminum
- 3 Bolt heavy duty flange
- Designed to fit 2-1/2" to 2-3/4" oil filter
- Perfect for engine, transmission and fluid filtration



Part No.
15709

Single - Side Ports

Kit Part No.	Mount Only Part No.	Filter Threads	Filter Landing	Inlet/Outlet Ports	Repl. Nipple
13049	25049	3/4"-16	2 1/2" to 2 3/4"	3/8" NPT	98020
15709	25709	3/4"-16	2 1/2" to 2 3/4"	1/2" NPT	98020
15729	25729	13/16"-16	2 1/2" to 2 3/4"	1/2" NPT	98021



Part No.
13005

Single - Ports Up

Kit Part No.	Mount Only Part No.	Filter Threads	Filter Landing	Inlet/Outlet Ports	Repl. Nipple
----	25044	3/4"-16	2 1/2" to 2 3/4"	1/4" NPT	98020
13005	25005	3/4"-16	2 1/2" to 2 3/4"	3/8" NPT	98020
15708	25708	3/4"-16	2 1/2" to 2 3/4"	1/2" NPT	98020
15728	25728	13/16"-16	2 1/2" to 2 3/4"	1/2" NPT	98021



Part No.
25750

Part No.
25753

Single - Ports Left or Right

Port Direction	Mount Only Part No.	Filter Threads	Filter Landing	Inlet/Outlet Ports	Rep.. Nipple
Left	25750	3/4"-16	2 1/2" to 2 3/4"	3/8" NPT	98020
Right	25751	3/4"-16	2 1/2" to 2 3/4"	3/8" NPT	98020
Left	25752	3/4"-16	2 1/2" to 2 3/4"	1/2" NPT	98020
Right	25753	3/4"-16	2 1/2" to 2 3/4"	1/2" NPT	98020



Dual - Side Ports

Kit Part No.	Mount Only Part No.	Filter Threads	Filter Landing	Inlet/Outlet Ports	Repl. Nipple
15707	25707	3/4"-16	2 1/2" to 2 3/4"	1/2" NPT	98020



THE LEADER IN PERFORMANCE COOLING

Engine Oil Filter Adapter Kits

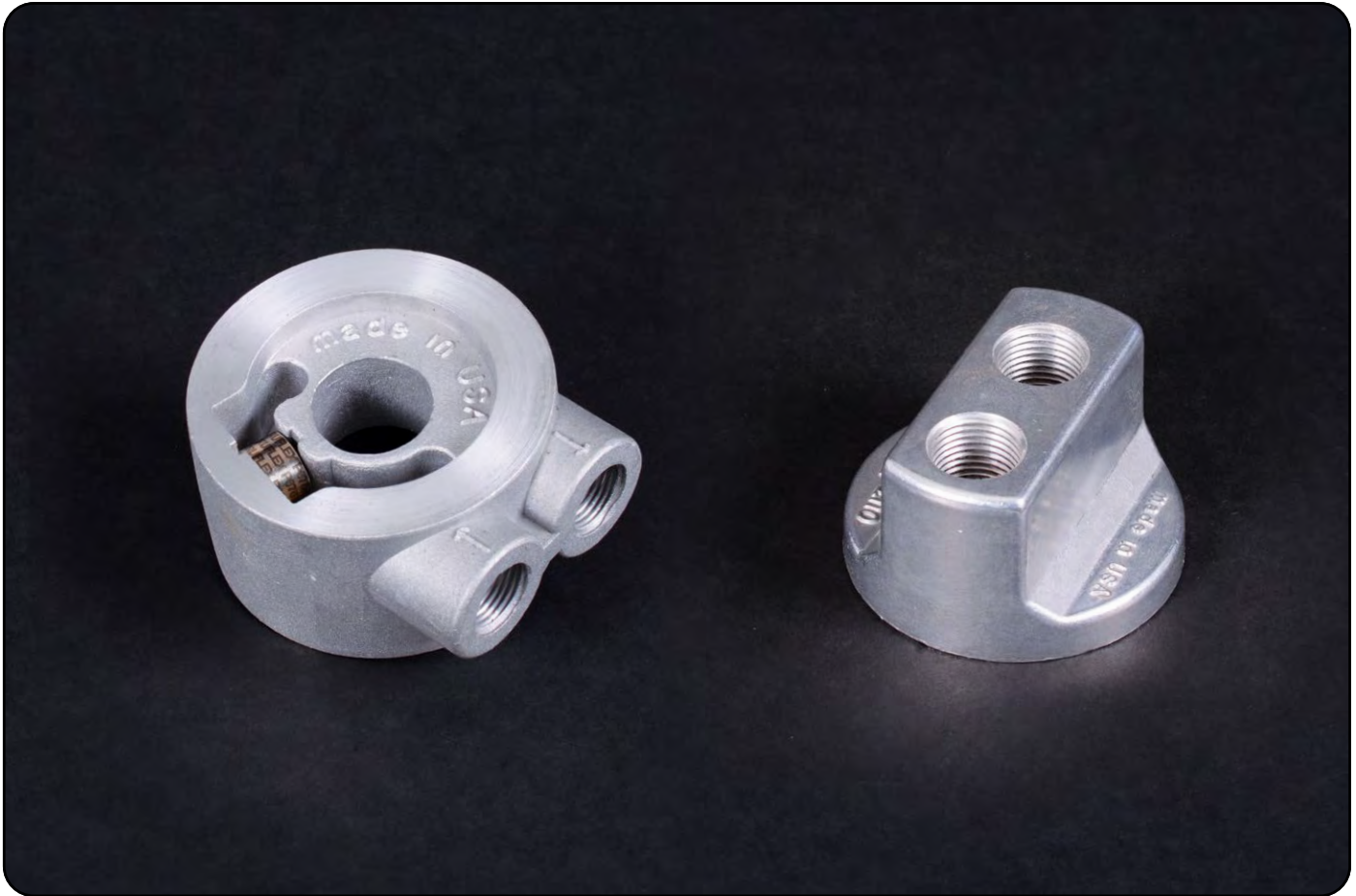

Sandwich

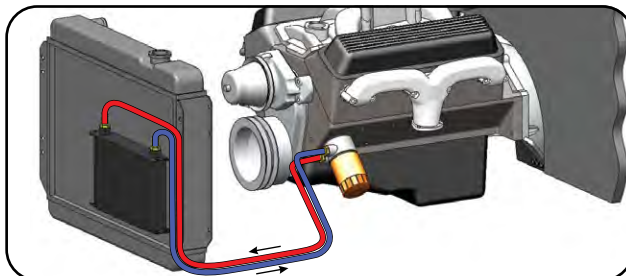
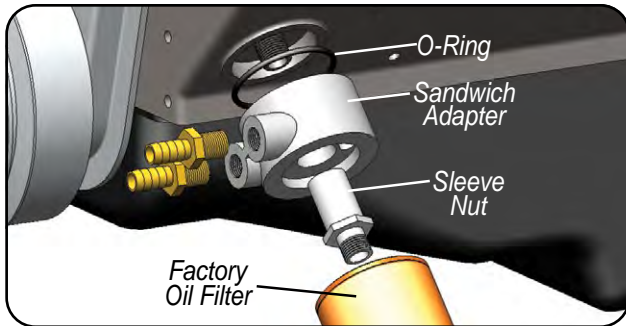

Spin-On

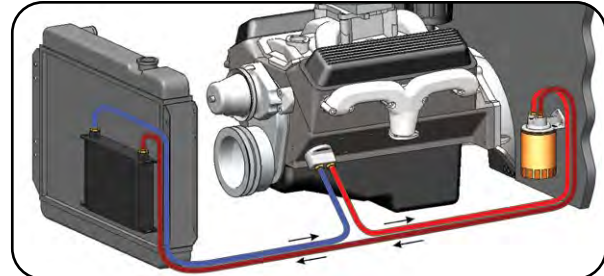
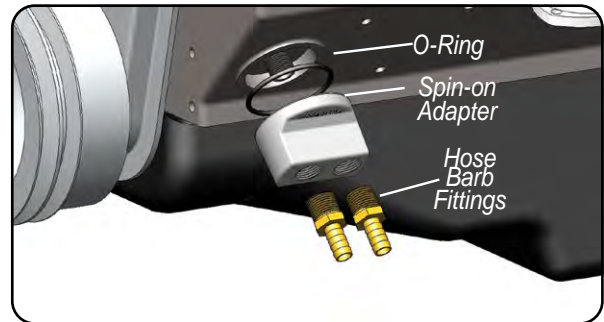

Engine Sandwich Adapters



A sandwich adapter provides external oil lines to allow the addition of an engine oil cooler. It installs between the stock engine oil filter landing and the oil filter. This allows for engine oil cooling power without relocating stock engine oil filter.

- Cast from high quality aluminum
- Four designs to fit most applications
- Maintains factory equivalent oil filter

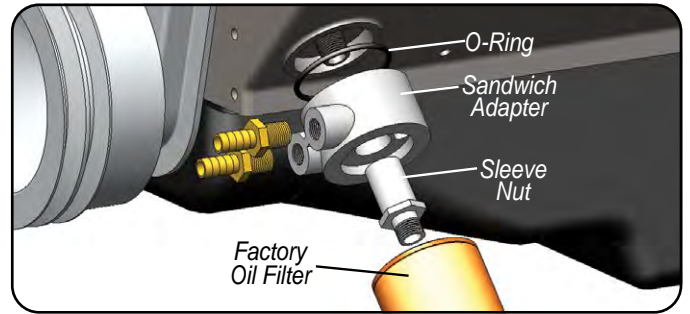

Thermostatic



This universal kit is manufactured of high-quality die-cast aluminum and includes an 180°F thermostatic sandwich adapter with 3/8" NPT ports and an o-ring diameter of 2 3/4". Kit includes sleeve nuts and hose barb fittings.

Thermostatic (GM Applications)

High quality die-cast aluminum thermostatic sandwich adapter with 1/2" NPT ports and an o-ring diameter of 3 1/2". It installs between the stock engine oil filter landing and the oil filter. Stock filter is retained. Kit includes sleeve nut and hose barb fittings.



Low-Profile



At only 1" thick, this high quality aluminum low profile sandwich adapter features 3/8" NPT ports and pressure relief valve and provides external oil lines to run an engine oil cooler while dropping the factory oil filter only 1" lower than stock.

Non-Thermostatic

This sandwich adapter was designed to one give a non-thermostatic option to consumers with high performance engines with 2 3/4" filter landings, and two to fit import vehicles with 2 1/2" diameter filter landings. Stock filter is retained. Kit includes sleeve nuts and hose barb fittings.



Complete Kit Part No.	Kit Part No.	Engine Thread Sizes	O-Ring Dia.	Thickness	Ports
Thermostatic					
15702	25702	3/4"-16, 13/16"-16, 18x1.5mm, 20x1.5mm, 22x1.5mm	2 1/2" to 2 3/4"	1 3/4"	3/8" NPT
15782	25782		2 3/4" to 3 1/2"	1 3/4" or 2 1/8"	3/8" NPT
15730	25730	3/4"-16	2 1/2" to 2 3/4"	1 3/4"	3/8" NPT
15731	25731	13/16"-16	2 3/4" to 3 1/2"	1 3/4" or 2 1/8"	3/8" NPT
15732	25732	20 x 1.5mm	2 1/2" to 2 3/4"	1 3/4"	3/8" NPT
15733	25733	18 x 1.5mm	2 1/2" to 2 3/4"	1 3/4"	3/8" NPT
15734	25734	22 x 1.5mm	2 1/2" to 2 3/4"	1 3/4"	3/8" NPT
Thermostatic (GM Applications Only)					
15720	25720	13/16"-16	3 1/2"	2 1/4"	1/2" NPT
Non-Thermostatic					
15735	----	3/4"-16, 13/16"-16, 18x1.5mm, 20x1.5mm, 22x1.5mm	2 3/4" to 3 1/2"	1 3/4"	1/2" NPT
Low Profile with pressure relief					
----	25770	3/4"-16	2 1/2" to 2 3/4"	1"	3/8" NPT
----	25771	13/16"-16	2 1/2" to 2 3/4"	1"	3/8" NPT
----	25772	20 x 1.5mm	2 1/2" to 2 3/4"	1"	3/8" NPT
----	25773	18 x 1.5mm	2 1/2" to 2 3/4"	1"	3/8" NPT
----	25774	22 x 1.5mm	2 1/2" to 2 3/4"	1"	3/8" NPT
----	25783	3/4"-16, 13/16"-16, 18x1.5mm, 20x1.5mm, 22x1.5mm	2 1/2" to 2 3/4"	1"	3/8" NPT



THE LEADER IN PERFORMANCE COOLING

Engine Spin-On Adapters

Spin-on adapters provide external oil lines to allow the addition of an engine oil cooler and/or remote filter mount, installing at the stock engine oil filter location. With an attractive, billet style look and ultra-bright, polished appearance it adds style and function.

- Quick and easy installation
- Relocate filter mounting for easier access
- Custom applications available

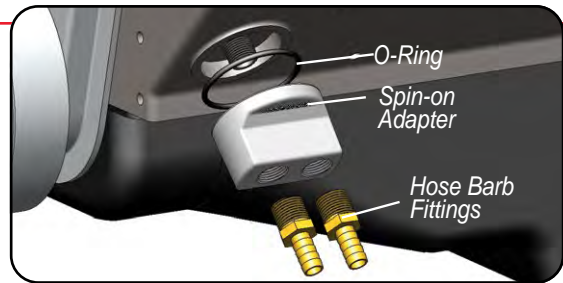

Ports-up Standard Series

- Ultra bright finish
- New Billet-style design
- Available in 6 numbers to fit all applications
- 1/2" NPT ports



Ports-up Premium Series

- Black powder coated finish
- New Billet-style design
- Available in 6 numbers to fit all applications
- -10 AN / 7/8"-14 O-Ring ports



Ports Left / Right Series

- Ultra bright finish
- 1/2" NPT ports



Style	Std. Series Part No.	Ports	Premium Series Part No.	Ports	Engine Thread Sizes	O-Ring Dia.
Ports-up	15747	1/2" NPT	35747	-10 AN o-ring	3/4"-16, 13/16"-16, 18x1.5mm, 20x1.5mm, 22x1.5mm	2 1/2", 2 3/4", 3 1/2"
Ports-up	15703	1/2" NPT	35703	-10 AN o-ring	3/4"-16	2 1/2", 2 3/4"
Ports-up	15704	1/2" NPT	35704	-10 AN o-ring	18 x 1.5mm	2 1/2", 2 3/4"
Ports-up	15705	1/2" NPT	35705	-10 AN o-ring	13/16"-16	2 1/2", 2 3/4", 3 1/2"
Ports-up	15706	1/2" NPT	35706	-10 AN o-ring	20 x 1.5mm	2 1/2", 2 3/4"
Ports-up	15724	1/2" NPT	35724	-10 AN o-ring	22 x 1.5mm	2 1/2", 2 3/4"
Ports Left / Right	15746	1/2" NPT	----	----	3/4"-16	2 1/2", 2 3/4"
Ports Left / Right	15758	1/2" NPT	----	----	13/16"-16	2 1/2", 2 3/4"
Ports Left / Right	15755	1/2" NPT	----	----	18 x 1.5mm	2 1/2", 2 3/4"
Ports Left / Right	15756	1/2" NPT	----	----	20 x 1.5mm	2 1/2", 2 3/4"
Ports Left / Right	15757	1/2" NPT	----	----	22 x 1.5mm	2 1/2", 2 3/4"



Part No. 15761

Mount Part No.	Inlet/Outlet Ports	Filter Landing
15761	13/16"-16	3 1/2"
98003	Replacement o-ring and gasket	

GM V-8 Spin-On Oil Filter Adapter

- Fits all 1956-1967 SB & BB V8's (except Chevy II) with canister style oil filter
- Converts factory canister style oil filter to a spin-on type oil filter
- Requires factory GM oil bypass
- Cast from high quality aluminum
- Uses Fram PH5, PH30 or equivalent oil filters



Part No. 15760

Mount Part No.	Inlet/Outlet Ports
NEW 35760	1/2" NPT
NEW 35762	7/8"-14 ORB
98004	Replacement o-ring Set

Billet Aluminum GM V-8 Bolt-On Oil Filter Adapter

- Fits all 1956-1991 SB & BB V8's with canister style oil filter
- Allows factory oil filter to be moved to a remote location
- Bolts directly to engine block replacing factory oil bypass
- Finned aluminum design with 1/2" NPT ports
- Cast from high quality aluminum

LS Engine Adapters



NEW
Part No. 35621



*NOTE: Fittings and temperature sensor not included.

LS THERMOSTATIC BYPASS ADAPTER

- Low profile designs maximizes header clearance
- Clears most long tube headers for LS swaps
- 6061 Billet Aluminum
- -10 AN ORB Ports for Maximum Flow
- Black anodized
- Flows up to 20 gallons per minute
- Rated at 200 psi
- Bolts and 1/8" NPT plugs included
- Viton O-Rings

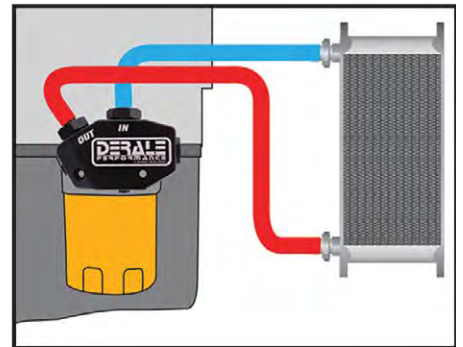

Bypass engine oil cooler during engine warm up with built-in 180°F Thermostat



LS ENGINE OIL COOLER ADAPTER

NEW
Part No. 35611



Engine side
Block-off Port



Block-Off Adapter features 1/8" NPT accessory port

LS ENGINE BLOCK-OFF ADAPTER

NEW
Part No. 35601



Engine side
Block-off Port

Ports Up



Part No.
13072



Side Ports



Part No.
13070



FILTER SPECS:

- 12 Micron
- 1" - 14 Thread size
- Filter Size: 3 1/2" OD x 7"
- 5/8" tall
- Filter Seal
- ID: 2.45" OD: 2.80"
- 100 P.S.I. Element burst pressure
- 300 P.S.I. Hydrostatic burst pressure

Fuel Filter / Water Separator

This fuel filter/water separator kit extends carburetor/injector life, improves engine performance and is designed to be used with all fuel types. Featuring a Made-in-USA high quality aluminum cast filter mount with 1/2" NPT side-ports and a 1"-14 filter thread, they feature a petcock located at the base of the filter to allow quick and easy water draining.

- Extends carburetor/fuel injector life
- Designed for all fuel types
- Improves engine performance
- Petcock allows for convenient draining of water

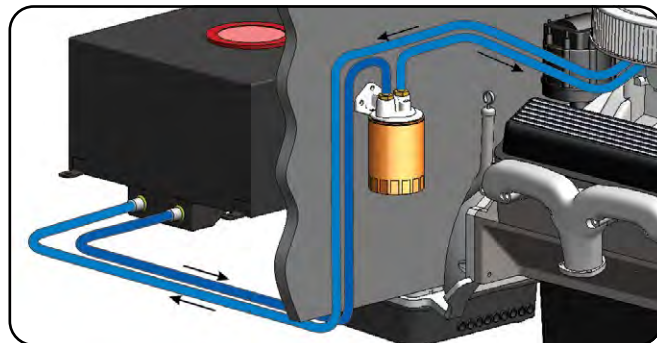

Part No.	Description	Filter Thread Size	Filter Landing	Inlet/Outlet Ports	Filter Dimensions
13070	Single Mount - Side Ports	1"-14	2 1/2" to 2 3/4"	1/2" NPT	3 1/2" O.D. x 7 5/8"
13072	Single Mount - Ports Up	1"-14	2 1/2" to 2 3/4"	1/2" NPT	3 1/2" O.D. x 7 5/8"
13075	Replacement Filter	1"-14	----	1/2" NPT	3 1/2" O.D. x 7 5/8"



Part No.
13090



Premium kits include the Derale temperature gauge kit

FILTER SPECS:

- Thread Size: 3/4"-16
- Filter Size: 3 1/2" OD x 3 1/8" Tall
- Burst pressure increases from 235 p.s.i. to 350 p.s.i.

Transmission Filter Kits

Our universal remote transmission filter kits enable quick and efficient filter changes and filter out contaminants that pass through OE-screen type filters. Another benefit is the increased fluid capacity which effectively cools fluid temperatures moderately and help extend the life of the transmission.

- Extends transmission life
- Increase fluid capacity for added cooling
- Higher efficiency than screen type filters
- Universal - Fits all automatic transmissions

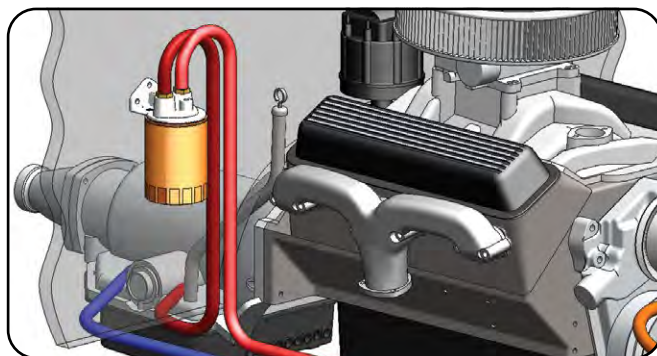

Part No.	Description	Filter Thread Size	Filter Landing	Inlet/Outlet Ports	Filter Dimensions
13090	Standard Kit	3/4"-16	2 1/2" to 2 3/4"	3/8" NPT	3 1/2" O.D. x 3 1/8"
13091	Premium Kit	3/4"-16	2 1/2" to 2 3/4"	3/8" NPT	3 1/2" O.D. x 3 1/8"
13092	Replacement Filter	3/4"-16	----	----	3 1/2" O.D. x 3 1/8"

Fittings and Accessories



THE LEADER IN PERFORMANCE COOLING

Magnetic Aluminum Vise Jaws

- 4" (one size) fits all vises
- V-shaped surface holds & helps protect round or hex parts

Part #
35000

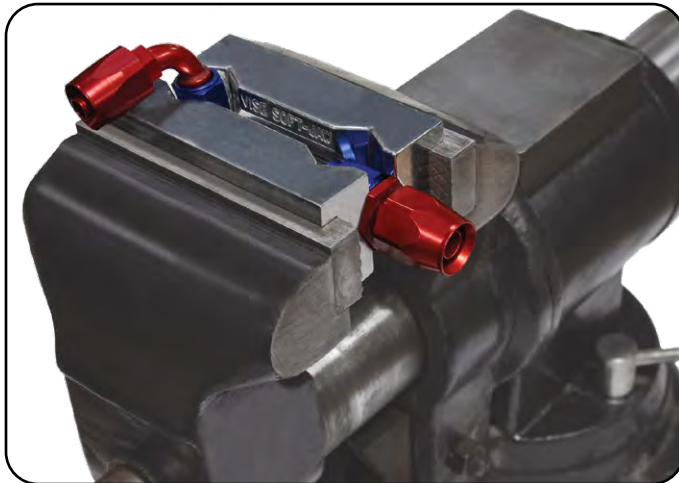

90° Hose Barb Fittings

Part No.	Description	U/M
98233	3/8" NPT Male x 3/8" Barb	Ea.
98234	3/8" NPT Male x 1/2" Barb	Ea.
98244	1/2" NPT Male x 1/2" Barb	Ea.

90° NPT Fittings



Part No.	Description	U/M
98333	3/8" NPT Female x 3/8" NPT Male	Ea.
98334	1/2" NPT Female x 1/2" NPT Male	Ea.

Barb to Barb Fittings



Part No.	Description	U/M
98028	3/8" Barb x 3/8" Barb	Ea.

Straight NPT Hose Barb Fittings



Part No.	Description	U/M
98104	1/4" Female x 3/8" Barb	Ea.
98105	3/8" Female x 3/8" Barb	Ea.
98106	1/2" Female x 1/2" Barb	Ea.

Filter Nipples



Part No.	Description	U/M
98020	3/4"-16	Ea.
98021	13/16"-16	Ea.

NPT Reducer Bushings



Part No.	Description	U/M
98450	3/8" Male x 1/8" Female	Ea.
98451	1/2" Male x 1/8" Female	Ea.
98452	1/2" Male x 3/8" Female	Ea.

Zinc Radiator Anode



Part No.	Description	U/M
98000	Fits radiator with 1/4" NPT drain petcock	Ea.

NPT Plugs



Part No.	Description	U/M
98400	1/2" NPT	Ea.
98410	1/8" NPT	Ea.

Thread Sealant Tape

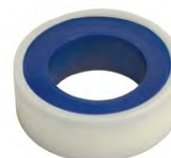

Part No.	Description	U/M
15714	1/2" x 43'	Ea.



THE LEADER IN PERFORMANCE COOLING

Transmission Cooling Pans



Features and Benefits

- Reduces fluid temperatures
- Increases fluid capacity
- Two stage heat-dissipating black finish
- 1/8" NPT temperature sender port
- Drain plug features increased magnet strength & reusable rubber/steel washer
- Applications to fit Ford, Dodge/Chrysler and GM vehicles
- Uses OEM filter
- Includes gasket

Dimensions

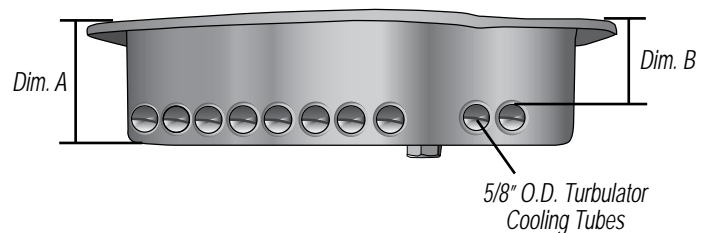

Built-in airflow cooling tubes make the Derale Transmission Cooling Pans the easiest way to combat excessive fluid temperatures. Cooling pans bolt right on with minimal or no modifications to stock chassis.



Ford • Dodge/Chrysler • GM

- ✓ 5/8" O.D. AIRFLOW COOLING TUBES
- ✓ EXTRA FLUID CAPACITY
- ✓ HEAT DISSIPATING BLACK FINISH
- ✓ RARE EARTH MAGNETIC DRAIN PLUG
- ✓ BUILT-IN 1/8" TEMP SENDER PORT

Airflow tubes feature built-in turbulators for maximum heat dissipation

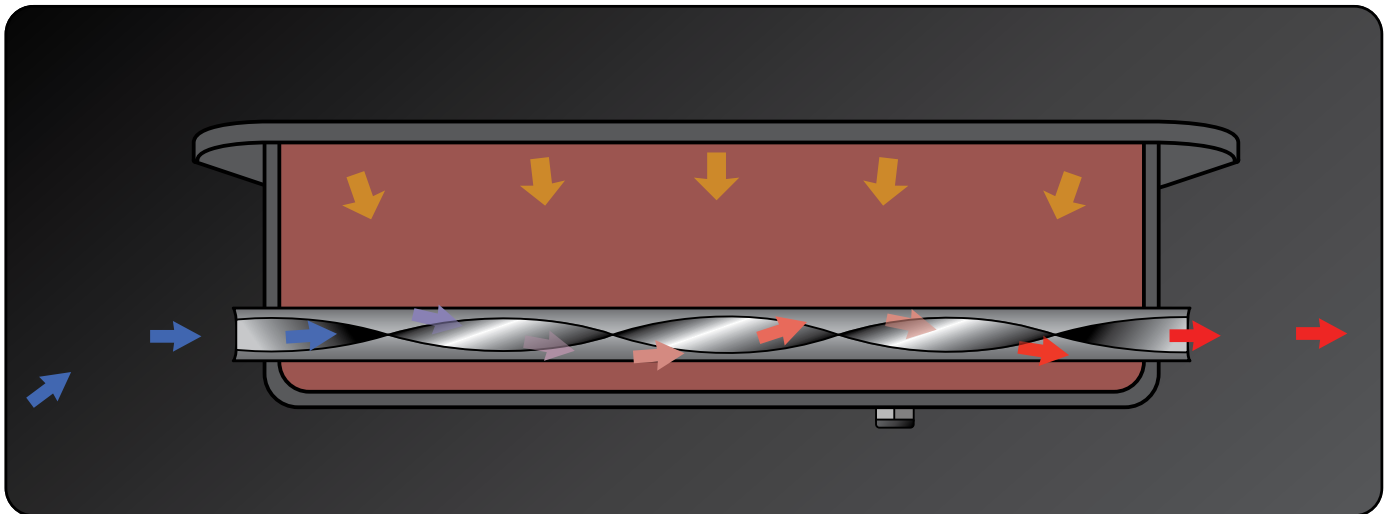

Derale Performance Transmission Cooling Pans feature 5/8" integrated airflow tubes that utilize natural airflow passing under the vehicle to cool transmission fluid temperatures.

1/8" NPT Temp Port



1/8" NPT Temp port allows for easy installation of temperature sending unit.



Magnetic Drain Plug



- 1/2"-20 Threads
- Increased magnet strength
- Rubber/Steel washer



THE LEADER IN PERFORMANCE COOLING



Chevy / GM Turbo 350

- Fits most GM Turbo 350 1968-1986 applications

Application	Part No.	Capacity	Dim. A Pan Depth	Dim. B Tube Depth	Rep. Gasket
GM Turbo 350	14200	2 qts	3 1/4"	2 3/8"	96900



Chevy / GM Turbo 400

- Standard: Fits most GM Turbo 400 1966-1990 applications
- Deep Pan: Fits most GM Turbo 400 1978-1990 applications

Application	Part No.	Capacity	Dim. A Pan Depth	Dim. B Tube Depth	Rep. Gasket
GM Turbo 400 Standard Pan	14201	1 qt 17 oz	2 7/8"	2"	96901
GM Turbo 400 Deep Pan	14202	Deep OE Pan to Deep Pan - 1 qt. 3 oz. Std. OE Pan to Deep Pan - 3 qts. 8 oz.	4"	3 1/16"	96901



Chevy / GM 4L80E

- Fits most GM 4L80E 1991-2008 applications

Application	Part No.	Capacity	Dim. A Pan Depth	Dim. B Tube Depth	Rep. Gasket
GM 4L80E	14207	4 qts. 16 oz.	4 1/16"	2 3/4"	96209



Chevy / GM 700R4 & 4L60E

- Fits most GM 700R4 & 4L60E 1992-1999 applications

Application	Part No.	Capacity	Dim. A Pan Depth	Dim. B Tube Depth	Rep. Gasket
GM 700R4, 4L60E	14204	2 qts. 4 oz.	3 5/8"	2 1/2"	96906



Ford E40D, 4R100, 5R110 & 5R110W

- Fits most E40D, 4R100, 5R110 & 5R110W
1989-2010 applications

Application	Part No.	Capacity	Dim. A Pan Depth	Dim. B Tube Depth	Rep. Gasket
Ford E40D, 4R100, 5R110 & 5R110W	14208	4R100 - 7 qts. 30 oz. 5R110 - 7 qts. 10 oz.	6 1/8"	4 3/8"	96908



Dodge / Chrysler A727, A904, A518 & A618

- Fits most Dodge/Chrysler A727, A904, A518 & A618
1989-2010 applications

Application	Part No.	Capacity	Dim. A Pan Depth	Dim. B Tube Depth	Rep. Gasket
Dodge A727, A904, A518 & A618	14210	Up to 5 qts. 16 oz.	4 1/2"	3 5/8"	96905

Transmission Cooling Pan Accessories

Filter Pickup Tube



Application:
GM TH400 Deep pan - Extends filter for use
on deep transmission pans.

Part No.	14002
----------	--------------

Universal Drain Plug Kit



- 1/8" NPT Plug
- Perfect for temp
sending units

Part No.	13010
----------	--------------

Deep Pan Filter Extender



Application:
Dodge A727, A904, A518 & A618 - Extends
filter for use on deep transmission pans.

Part No.	14010
----------	--------------

Magnetic Drain Plug Kit



- 1/2"-20 Threads
- Increased
magnet strength
- Rubber/Steel washer

Part No.	14000
----------	--------------



THE LEADER IN PERFORMANCE COOLING

High Output Single Rad Fan Aluminum Powerpacks

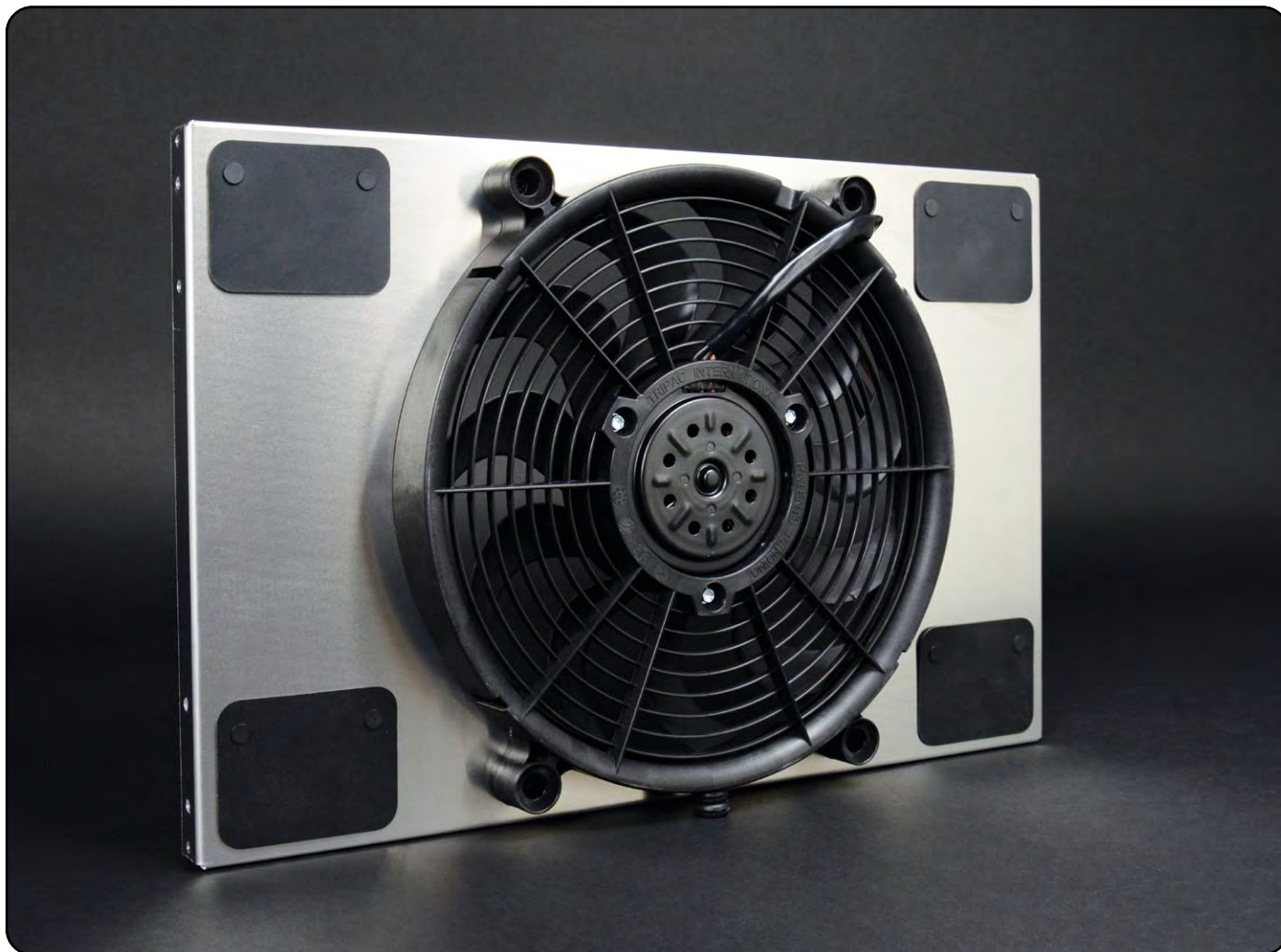

Features and Benefits

- Powerful, primary cooling fans eliminate fuel & horsepower-robbing belt driven fan
- Aircraft-quality natural satin aluminum finish can be polished, painted or anodized
- Increases fuel economy
- Multiple mounting options
- Includes illustrated instructions and mounting hardware

Fan Controllers sold separately, see page 74-76.

Dimensions

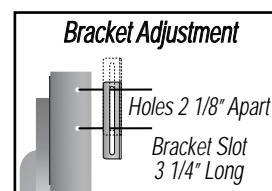
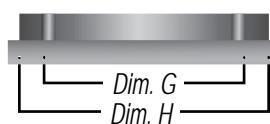
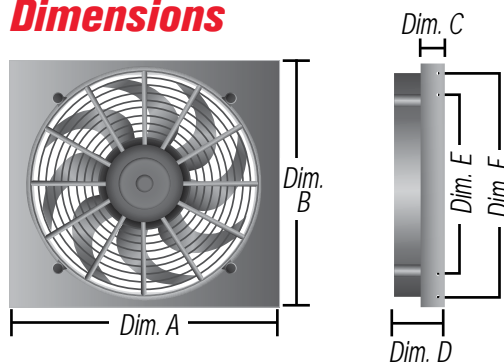



Optional Integrated PWM Controller

Hardware kit



A17 Single Powerpack

- High output 265-watt two speed motor
- Puller (engine side) applications only



Part No. 16819

Part No.	With PWM Controller	Repl. Fan	CFM* High/Low	Amp Draw High/Low	Dim A. (Width)	Dim B. (Height)	Dim C. (Depth)	Dim D. (Overall Depth)	Dim E. (Mounting)	Dim F. (Mounting)	Dim G. (Mounting)	Dim H. (Mounting)
16816	-----	16917	2400 / 1800	23.5 / 17.4	16 3/4"	17 5/8"	1 1/8"	3"	8 7/8"	13 1/8"	11"	15"
16818	66818	16917	2400 / 1800	23.5 / 17.4	18"	18"	1 1/8"	3"	10 1/8"	14 1/2"	11 1/8"	15 1/2"
16819	66819	16917	2400 / 1800	23.5 / 17.4	18 3/4"	17 5/8"	1 1/8"	3"	10 3/4"	15"	11"	15 1/4"
16821	66821	16917	2400 / 1800	23.5 / 17.4	20 3/4"	17 5/8"	1 1/8"	3"	10 7/8"	15 1/8"	13"	17 1/4"
16822	66822	16917	2400 / 1800	23.5 / 17.4	22 1/4"	17 5/8"	1 1/8"	3"	10 3/4"	15"	14 3/8"	18 5/8"
16823	66823	16917	2400 / 1800	23.5 / 17.4	21"	16 3/4"	1 1/8"	3"	9 7/8"	14 1/8"	13 1/8"	17 3/8"
16828	66828	16917	2400 / 1800	23.5 / 17.4	24"	17"	1 1/8"	3"	10 1/4"	14 3/8"	16 1/8"	20 3/8"
Powder coated Steel Shroud												
16919	-----	16917	2400 / 1800	23.5 / 17.4	19 1/2"	18"	1 1/8"	3"	9"	11"	---	---



Optional Integrated PWM Controller

Hardware kit

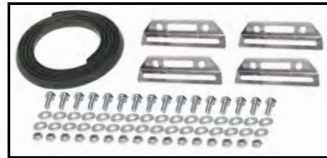

A14 Single Powerpack

- High output 265-watt two speed motor
- Puller (engine side) applications only
- Air pressure relief vents (Excludes 16817)



Part No. 16820

Part No.	With PWM Controller	Repl. Fan	CFM* High/Low	Amp Draw High/Low	Dim A. (Width)	Dim B. (Height)	Dim C. (Depth)	Dim D. (Overall Depth)	Dim E. (Mounting)	Dim F. (Mounting)	Dim G. (Mounting)	Dim H. (Mounting)
16817	-----	16913	2100 / 1500	22 / 16.2	17"	16 3/8"	1 1/8"	2 3/4"	4 1/4"	13 1/2"	9 1/2"	14"
16820	66820	16913	2100 / 1500	22 / 16.2	20"	16 3/8"	1 1/8"	2 3/4"	12 1/4"	16 1/2"	9 5/8"	13 7/8"
16827	66827	16913	2100 / 1500	22 / 16.2	23 7/16"	15 7/16"	1 1/8"	2 3/4"	8 5/8"	12 7/8"	15 5/8"	19 7/8"



Hardware kit



A12 Single Powerpack

- High output 300-watt motor
- Puller (engine side) applications only
- Air pressure relief vents



Part No. 16814

See page 62 for hole dimension legend.

Part No.	Repl. Fan	CFM*	Amp Draw	Dim A. (Width)	Dim B. (Height)	Dim C. (Depth)	Dim D. (Overall Depth)	Dim E. (Mounting)	Dim F. (Mounting)	Dim G. (Mounting)	Dim H. (Mounting)
16814	16924	2000	24.8	18"	12 7/8"	2 3/4"	4"	5 1/8"	11 3/4"	9 3/8"	16"



THE LEADER IN PERFORMANCE COOLING

High Output Dual Rad Fan Aluminum Powerpacks



Features and Benefits

- Powerful, primary cooling fans eliminate fuel & horsepower-robbing belt driven fans
- Aircraft-quality natural satin aluminum finish can be polished, painted or anodized
- Increases fuel economy
- Multiple mounting options
- Includes illustrated instructions and mounting hardware

Fan Controllers sold separately, see page 74-76.

Dimensions

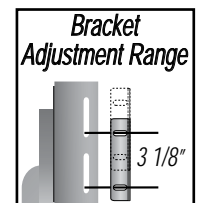
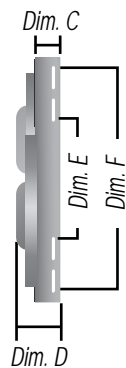
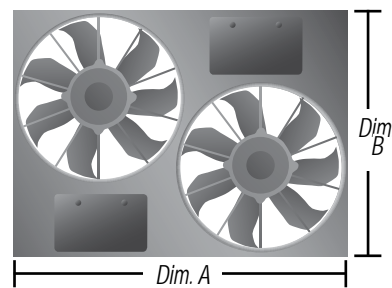



Optional Integrated PWM Controller

Part No. 16836

A12 Dual Powerpack

- High output 300-watt motors
- Puller (engine side) applications only
- Optional integrated PWM fan controller
- Sealed waterproof and dustproof, IP68 Certified
- Air pressure relief vents (Excludes 16825 & 66825)

Hardware kit

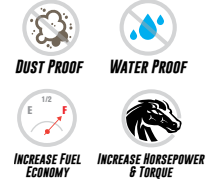

Part No.	With PWM Controller	Repl. Fan	CFM*	Amp Draw	Dim A. (Width)	Dim B. (Height)	Dim C. (Depth)	Dim D. (Overall Depth)	Dim E. (Mounting)	Dim F. (Mounting)	Dim G. (Mounting)	Dim H. (Mounting)
16825	66825	16924	4000	49.6	25 5/8"	15 1/8"	2 3/4"	4"	7 5/8"	13 5/8"	17 3/8"	23 3/8"
16826	66826	16924	4000	49.6	25 5/8"	17 1/8"	2 3/4"	4"	9 5/8"	15 5/8"	17 3/8"	23 3/8"
16836	66836	16924	4000	49.6	26 3/8"	16"	2 3/4"	4"	8 1/2"	14 1/2"	18 1/8"	24 1/8"
16837	66837	16924	4000	49.6	27"	18"	2 3/4"	4"	10 1/2"	16 1/2"	18 3/4"	24 3/4"
16838	66838	16924	4000	49.6	28 1/4"	17"	2 3/4"	4"	9 1/2"	15 1/2"	20"	25 7/8"
16842	66842	16924	4000	49.6	26"	18"	2 3/4"	4"	10 1/2"	16 1/2"	17 3/4"	23 3/4"
Steel Shroud (Powder coated Silver)												
16927	66927	16924	4000	49.6	26"	18"	2 3/4"	4"	10 1/2"	16 1/2"	17 3/4"	23 3/4"



Optional Integrated PWM Controller

Part No. 16833

A11 Dual Powerpack

- High output 225-watt motors
- Puller (engine side) applications only
- Optional integrated PWM fan controller
- Air pressure relief vents

Hardware kit



Part No.	With PWM Controller	Repl. Fan	CFM*	Amp Draw	Dim A. (Width)	Dim B. (Height)	Dim C. (Depth)	Dim D. (Overall Depth)	Dim E. (Mounting)	Dim F. (Mounting)	Dim G. (Mounting)	Dim H. (Mounting)
16830	66830	16920	3750	37.4	22 1/2"	19"	2 3/4"	4 1/2"	11 1/2"	17 1/2"	14 1/4"	20 1/4"
16831	66831	16920	3750	37.4	24"	15 1/2"	2 3/4"	4 1/2"	7 15/16"	13 15/16"	15 3/4"	21 3/4"
16833	66833	16920	3750	37.4	24"	17"	2 3/4"	4 1/2"	9 1/2"	15 1/2"	15 3/4"	21 3/4"
16835	66835	16920	3750	37.4	23 3/4"	19 3/4"	2 3/4"	4 1/2"	12 1/4"	18 1/4"	15 1/2"	21 1/2"



THE LEADER IN PERFORMANCE COOLING

High Output Dual Rad Fan Aluminum Powerpacks



See page 60 for mounting dimensions legend.

A10S Dual Powerpack

- 2 High output motors
- Puller (engine side) applications only
- Ultra-quiet skewed blade design

Hardware kit

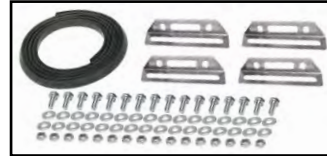

Part No.	Repl. Fan	CFM*	Amp Draw	Dim A. (Width)	Dim B. (Height)	Dim C. (Depth)	Dim D. (Overall Depth)	Dim E. (Mounting)	Dim F. (Mounting)	Dim G. (Mounting)	Dim H. (Mounting)
NEW 16812	16110	1650	18.4	24 3/4"	11 1/2"	1 1/8"	3 1/4"	17"	21 1/4"	4 5/8"	9 1/4"



See page 60 for mounting dimensions legend.

A12S Dual Powerpack

- 2 High output motors
- Puller (engine side) applications only
- Ultra-quiet skewed blade design
- Designed for maximum performance at high-static pressure loads

Hardware kit



Part No.	Repl. Fan	CFM*	Amp Draw	Dim A. (Width)	Dim B. (Height)	Dim C. (Depth)	Dim D. (Overall Depth)	Dim E. (Mounting)	Dim F. (Mounting)	Dim G. (Mounting)	Dim H. (Mounting)
NEW 16850	16112	2675	28.4	26"	14"	1-1/8"	3-3/4"	18"	22-1/2"	11"	12-1/2"



See page 60 for mounting dimensions legend.

A17 Dual Powerpack

- 2 High output 265-watt two speed motors
- Puller (engine side) applications only
- Ultra-quiet skewed blade design
- Designed for maximum performance at high-static pressure loads

Hardware kit

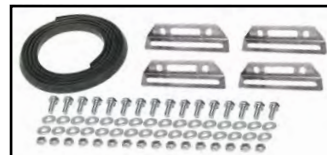

Part No.	Repl. Fan	CFM*	Amp Draw	Dim A. (Width)	Dim B. (Height)	Dim C. (Depth)	Dim D. (Overall Depth)	Dim E. (Mounting)	Dim F. (Mounting)	Dim G. (Mounting)	Dim H. (Mounting)
NEW 16843	18217	4800 / 3600	47 / 34.8	34"	17-1/4"	1 1/8"	3 3/4"	26-1/4"	30-1/2"	14-3/4"	16 1/2"

High Output Rad Fan Molded Powerpacks



Features and Benefits

- Powerful, primary cooling fans eliminate fuel & horsepower-robbing belt driven fans
- Increases fuel economy
- Fan housing includes stator-flow directors
- Ultra-quiet patented skewed-blade design
- Includes illustrated instructions and mounting hardware

Fan Controllers sold separately, see page 74-76.

Dimensions

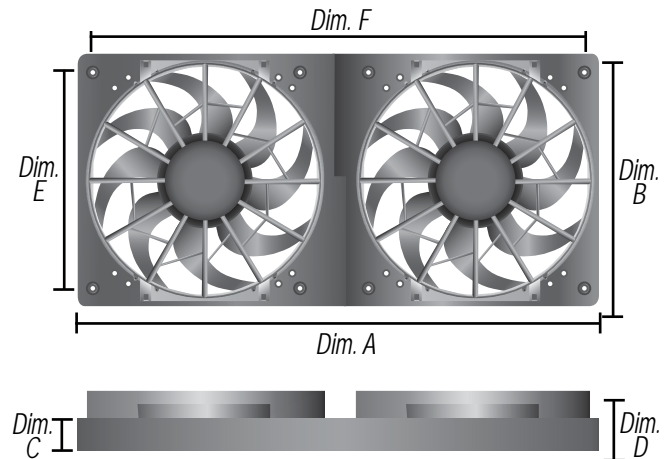

Hardware kit

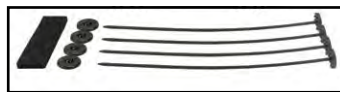

Hardware Kit Only Part # 13001

M12 Single Vented Powerpack

- High output 265-watt motor
- Puller (engine side) applications only
- Air pressure relief vents



Part No.	Repl. Fan	CFM*	Amp Draw	Dim A. (Width)	Dim B. (Height)	Dim C. (Depth)	Dim D. (Overall Depth)	Dim E. (Mounting)	Dim F. (Mounting)
16926	16925	2000	23.4	15 3/4"	15 3/4"	1 7/8"	3 1/4"	12 7/8"	12 7/8"



Part No. 16928

M12 Dual Vented Powerpack

- High output 265-watt motor(s)
- Puller (engine side) applications only
- Air pressure relief vents (Excludes 16928)

Hardware kit



Hardware Kit Only Part # 13001 (2 Required)



Part No.	Repl. Fan	CFM*	Amp Draw	Dim A. (Width)	Dim B. (Height)	Dim C. (Depth)	Dim D. (Overall Depth)	Dim E. (Mounting)	Dim F. (Mounting)
16928	16925	4000	46.8	28 5/8"	13 7/8"	1 1/2"	3 1/4"	11 3/8"	25 5/8"
16934	16925	4000	46.8	31 3/8"	15 3/4"	1 3/8"	3 1/4"	12 7/8"	28 7/8"



THE LEADER IN PERFORMANCE COOLING

High Output Electric Fans



Features and Benefits

- **Designed for maximum performance at high static-pressure loads for more effective cooling**
- **Powerful, reliable motors provide years of trouble-free service**
- **Increases engine horsepower and torque**
- **Mounting hardware included**

Fan Controllers sold separately, see page 74-76.

Dimensions

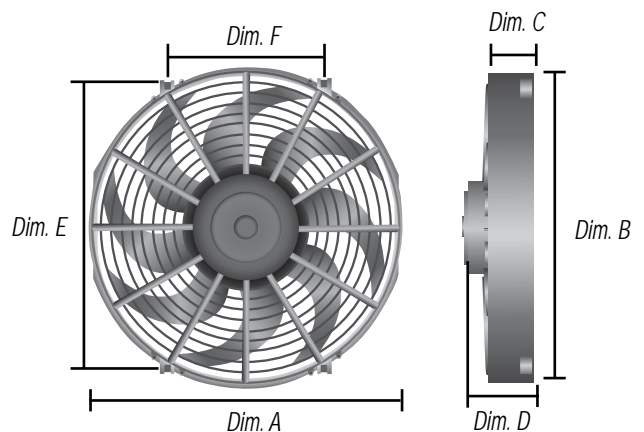



Part No.
16217/
18217

High Output Single Rad Fans

- High output 265-watt 2 speed motors
- State of the art symmetrical design can be used as a pusher or a puller without flipping blade or reversing polarity
- Ultra quiet patented blades
- Premium - patented ratchet mounting system
- Standard - push-through plastic rod mount system



Premium kit



Standard kit

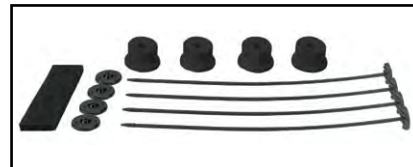

Premium Part No.	Standard Part No.	Fan Size	Airflow	CFM* High / Low	Amp Draw High / Low	Dim A. (Width)	Dim B. (Height)	Dim C. (Depth)	Dim D. (Overall Depth)	Dim E. (Mounting)	Dim F. (Mounting)
16212	18212	12"	Reversible	1450 / 1000	21 / 15	12 3/4"	12 3/4"	N/A	2 5/8"	8 1/4"	11 5/8"
16214	18214	14"	Reversible	2100 / 1500	22 / 16.2	14 1/2"	14 1/2"	N/A	2 5/8"	8 3/4"	13 1/4"
16217	18217	17"	Reversible	2400 / 1800	23.5 / 17.4	16 7/8"	16 7/8"	N/A	2 5/8"	2 5/8"	15 3/8"



Part No.
16136

Part No.
16114

Part No.
16142

High Output Extreme Single Fans

- Sealed waterproof/dustproof designs (IP68 Certified) are perfect for off-road and all season environments
- Ultra-low profile designs (Part no.'s 16110 & 16112)
- Paddle blades pull large volumes of air for maximum heat-extraction capabilities in more compact package
- Puller (engine side) applications only



Part No.
16105



Part No.
16104

Hardware kit

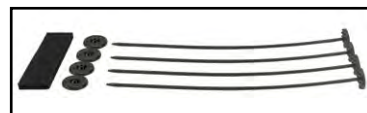

Hardware Kit Only Part # 16744



Part No.	Fan Size	Airflow	Blade Style	CFM*	Amp Draw	Dim A. (Width)	Dim B. (Height)	Dim C. (Depth)	Dim D. (Overall Depth)	Dim E. (Mounting)	Dim F. (Mounting)
16104	4"	Puller	Paddle	125	1.9	4 1/4"	4 1/4"	1 1/4"	2 3/8"	3 1/4"	3 1/4"
16105	5"	Puller	Paddle	315	3.6	5 5/8"	6 1/4"	1 1/4"	2 1/4"	4 1/4" - 3 hole mount	
16108	8"	Puller	Straight	366	5.5	8"	8 1/4"	1 1/4"	2"	5 15/16"	5 15/16"
16109	9"	Puller	Curved	625	7.2	9 11/16"	9 11/16"	1 1/8"	2"	5 1/2"	8 1/8"
16119	9"	Puller	Paddle	755	10	9 3/8"	9 3/4"	3 1/8"	3 3/4"	5 1/2"	8 1/8"
16110	10"	Puller	Curved	802	9.2	10 9/16"	11 1/8"	1 1/8"	2 1/16"	9 11/16"	5 13/16"
16920	11"	Puller	Paddle	1380	11	12"	12"	2 1/4"	4"	6 3/4"	11 1/2"
16112	12"	Puller	Curved	1328	14.2	12 9/16"	13 3/16"	1 1/8"	2 7/16"	11 7/16"	6 5/8"
16918	12"	Puller	Paddle	1350	16.0	12"	12"	1 5/8"	3 1/2"	10 5/8"	7 7/8"
16142	13"	Puller	Paddle	1640	21.8	13 1/16"	13 1/16"	2 1/4"	3 3/4"	9 5/16"	9 5/16"
16114	14"	Puller	Curved	1864	21.5	14 7/16"	15 1/16"	1 1/8"	3 7/16"	13 1/16"	7 9/16"
16116	16"	Puller	Curved	2024	21.0	15 11/16"	16 1/4"	1 1/8"	3 7/16"	14 1/16"	8 1/8"
16136	16"	Puller	Curved	1918	25.4	15 11/16"	15 11/16"	2 1/16"	3 3/4"	14 1/16"	8 1/8"



Part No.
16516/
16626/
16016



Part No.
16507/
16617



Tornado Single Fans

- 16" and 14" sizes designed as primary cooling fans eliminate fuel & horsepower-robbing belt driven fans
- Ultra-quiet patented skewed blade design
- Premium - Includes mounting kit, lighted toggle switch and wiring
- Standard - Includes mounting kit
- Fan and thermostat part no. includes mounting kit, 180°F thermostat, probes and relay harness

Premium kit



Standard kit

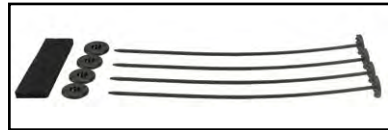

Fan w/ Thermostat kit



Premium Part No.	Standard Part No.	Fan w/Thermostat Part No.	Fan Size	Airflow	CFM*	Amp Draw	Dim A. (Width)	Dim B. (Height)	Dim C. (Depth)	Dim D. (Overall Depth)	Dim E. (Mounting)	Dim F. (Mounting)
16507	16617	-----	7"	Reversible	400	4.8	7 1/4"	7 1/8"	1 3/8"	2 3/8"	5 3/8"	5 3/8"
16508	16618	-----	8"	Reversible	500	4.8	8 1/4"	8"	1 3/8"	2 3/8"	6"	6"
16509	16619	-----	9"	Reversible	570	5.4	9 5/8"	9 1/2"	1 1/4"	2 1/2"	8 7/8"	5"
16510	16620	16010	10"	Reversible	650	5.3	11 1/4"	10 5/8"	1 1/2"	2 1/2"	9 5/8"	6 7/8"
16512	16622	16012	12"	Reversible	880	8.8	12 1/2"	11 1/2"	1 1/2"	2 1/2"	11 1/8"	5 7/8"
16514	16624	16014	14"	Reversible	1350	10.5	14 1/2"	14"	1 3/4"	3 1/4"	12 1/4"	9"
16516	16626	16016	16"	Reversible	2175	18.4	16 3/4"	15 3/4"	1 3/4"	4 1/8"	13 3/4"	9 3/4"



Part No.
16834



Tornado Dual Fans w/ Brackets

- Available with dual 12" or 14" Tornado fans
- Sturdy metal bracket system
- Black powder coated finish
- Can be used for pusher or puller applications

Part No.	Fan Size	Airflow	CFM*	Amp Draw (Fan 1 / 2)	Dim A. (Width)	Dim B. (Height)	Dim C. (Overall Depth)	Dim D. (Mounting)	Dim E. (Mounting)	Dim F. (Mounting)
16824	Dual 12"	Reversible	1760	8.8 / 8.8	27 3/4"	14"	2 1/2"	10 1/8"	13 5/8"	23 1/2"
16834	Dual 14"	Reversible	2700	10.5 / 10.5	31 3/4"	15 5/8"	3 1/4"	12 1/8"	14 5/8"	27 1/2"

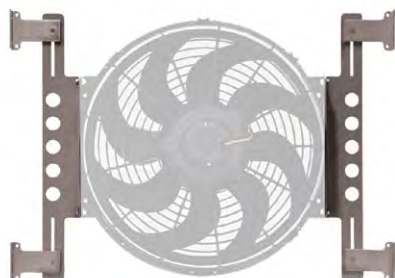

Part No.
16700

Tornado Fan Mounting Brackets

- Fits 10", 12", 14" & 16" Tornado Fans
- Adjustable universal mounting
- Hardware included

Part No.	Description
16700	Single fan mounting brackets (Clear anodized aluminum finish)
16701	Dual fan mounting brackets (Black powder coated finish) see brackets in above photo

* CFM tested at zero static pressure.

High Output Electric Fans



Part No.
16913



Part No.
16925



Part No.
16924

Part No.	Fan Size	CFM* High / Low	Amp Draw High / Low	Dim A. (Width)	Dim B. (Height)	Dim C. (Depth)	Dim C. (Overall Depth)	Dim E. (Mounting)	Dim F. (Mounting)
16913	14"	2100 / 1500	22 / 16.2	14 1/2"	14 1/2"	1 5/8"	2 5/8"	13 1/4"	8 3/4"
16917	17"	2400 / 1800	23.5 / 17.4	16 7/8"	16 7/8"	1 5/8"	2 5/8"	15 5/8"	8 7/8"
16924	12"	2000	24.8	13 1/8"	13 1/8"	2 3/8"	3 1/2"	9 3/8"	9 3/8"
16925	12"	2000	23.4	12 5/8"	12 5/8"	1 1/2"	3 1/8"	10 5/8"	7 7/8"

Do It Yourself - Drop-in Single RAD Fans For The D.I.Y. Pros at Home!

Installing as a Pusher

Mounting kit included for Pusher installation.
No shroud necessary.

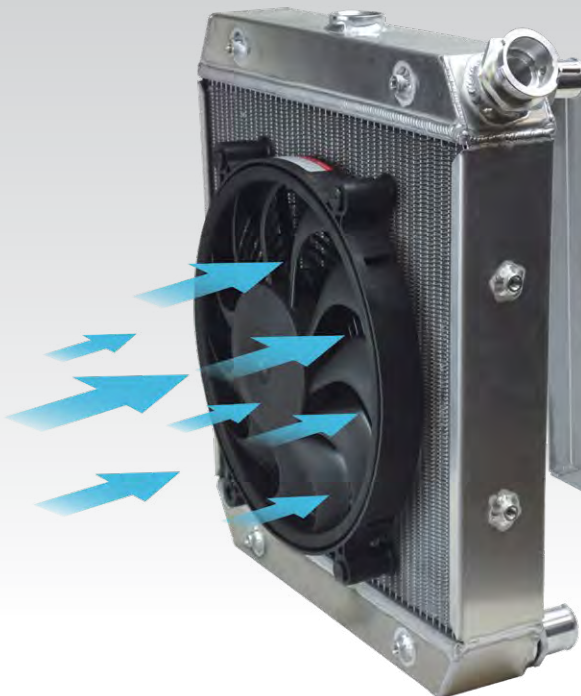

Installing as a Puller

Choose from 1 of 4 pusher style fans that can be pullers by using your custom built shroud.** All fans come complete with detailed drawing of all cut out and hole dimensions.

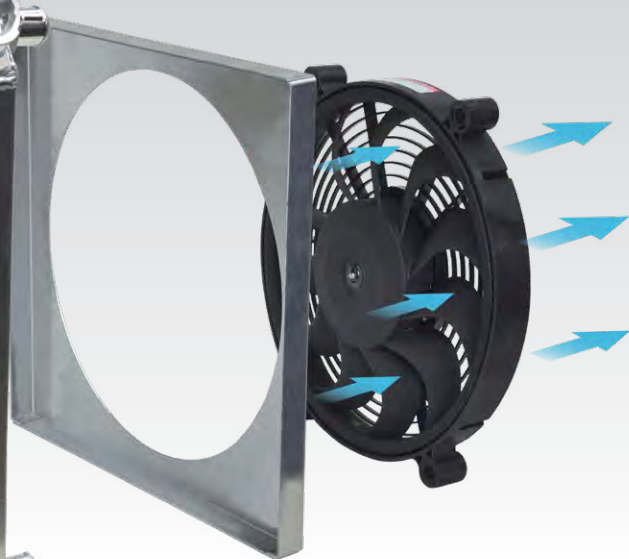

**Custom built shroud not included.



Part No.
18916



Part No.
18910

Dyno-Cool - Curved Blade Fans

- Powerful high-watt motors
- Low profile designs
- Quiet and efficient balanced curved blades
- Fully reversible for pusher or puller applications



Hardware kit

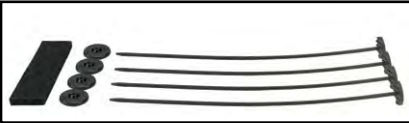

Hardware Kit Only Part # 16744

Part No.	Fan Size	Airflow	CFM*	Amp Draw	Dim A. (Width)	Dim B. (Height)	Dim C. (Depth)	Dim D. (Overall Depth)	Dim E. (Mounting)
18910	10"	Reversible	590	5.3	11 1/2"	10 3/4"	1 1/4"	2 3/8"	8 7/8"
18912	12"	Reversible	810	8.3	12 1/4"	12 1/4"	1 1/4"	2 3/8"	4 1/4"
18914	14"	Reversible	1230	9.7	14 7/8"	14 1/8"	1 1/4"	3 1/8"	6 3/4"
18916	16"	Reversible	1980	17.3	16 1/2"	15 3/4"	1 3/4"	3 7/8"	14 1/4"



Part No.
16314/16914



Part No.
16309/16909

Dyno-Cool - Straight Blade Fans

- Powerful high-watt motors
- Low profile designs
- Fully reversible for pusher or puller applications
- Premium kit includes adjustable thermostat



Premium kit



Standard kit

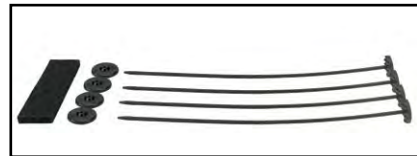

Premium Part No.	Standard Part No.	Fan Size	Airflow	CFM*	Amp Draw	Dim A. (Width)	Dim B. (Height)	Dim C. (Depth)	Dim D. (Overall Depth)	Dim E. (Mounting)
16308	16908	8"	Reversible	350	5.3	8 1/8"	8"	1 1/4"	2 1/4"	4 3/8"
16309	16909	9"	Reversible	475	5.5	9 9/16"	10 7/16"	1 1/4"	2 1/4"	8 7/16"
16310	16910	10"	Reversible	625	6.4	11"	11 1/4"	1 1/8"	2 3/8"	5 3/4"
16312	16912	12"	Reversible	725	9.0	11 3/8"	12 3/8"	1 1/8"	2 3/8"	4 3/4"
16314	16914	14"	Reversible	1225	12.4	14 1/8"	14 3/4"	1 1/4"	3 1/4"	7 1/8"
16316	16916	16"	Reversible	1680	15.5	16"	16 7/8"	1 1/4"	3 7/8"	8 1/8"

* CFM tested at zero static pressure.

Electric Fan Accessories



Plastic Rod Mounting Kits

- Complete electric fan mounting kit



Part No.	Description
13001	Plastic rod mounting kit
16744	Plastic rod kit with mounting feet

Complete Plastic Rod Installation Kits

- Complete electric fan installation kit



Part No.	Description
16745	Complete plastic rod installation kit
16742	Complete plastic rod kit with mounting feet

Metal Rod Mounting Kits

- Complete electric fan mounting kit
- Complete electric fan installation kit



Part No.	Description
16743	Metal rod mounting kit
16741	Complete metal rod installation kit

H.O. RAD Fan Premium Mounting Kit

- Patented adjustable mounting system for Derale part numbers 16212, 16214, 16217, 18212, 18214 & 18217

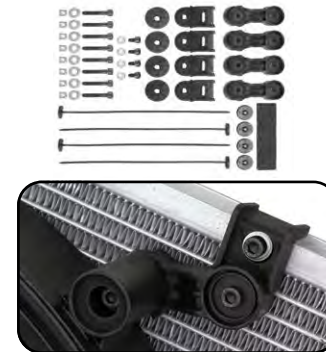

Part #
16746

Circuit Breakers

- Auto resetting design



Part No.	Description
16751	25 Amp circuit breaker
16754	50 Amp circuit breaker

Lighted Toggle Switch

- 3 pole, 12 volt switch
- Rocker type switch



Part No.
16740





Relay Wire Harness Kits



Part No.	Description
16763	40/60 Amp Single Relay Wire Harness
16765	40/60 Amp Dual Relay Wire Harness
16764	40/60 Amp Relay

Shrouded Electric Fans - Quick Guide



Shroud Size	Width	Height	Overall Depth	Part No.	Part No w/ PWM Controller	Description	CFM*	Amp Draw	Page
15" - 19"	15 3/4"	15 3/4"	3 1/4"	16926	---	M12 Powerpack, Single Fan	2000	23.4	61
	16 3/4"	17 5/8"	3"	16816	---	A17 Powerpack, Single Fan	2400 / 1800	23.5 / 17.4	57
	17"	16 3/8"	2 3/4"	16817	---	A14 Powerpack, Single Fan	2100 / 1500	22 / 16.2	57
	18"	13"	4"	16814	---	A12 Powerpack, Single Fan	2000	24.8	57
	18"	18"	3"	16818	66818	A17 Powerpack, Single Fan	2400 / 1800	23.5 / 17.4	57
	18 3/4"	17 5/8"	3"	16819	66819	A17 Powerpack, Single Fan	2400 / 1800	23.5 / 17.4	57
19" - 24"	19 1/2"	18"	3 5/8"	16919	---	S17 Powerpack, Single Fan	2400 / 1800	23.5 / 17.4	57
	20"	16 3/8"	2 3/4"	16820	66820	A14 Powerpack, Single Fan	2100 / 1500	22 / 16.2	57
	20 3/4"	17 5/8"	3"	16821	66821	A17 Powerpack, Single Fan	2400 / 1800	23.5 / 17.4	57
	21"	16 3/4"	3"	16823	66823	A17 Powerpack, Single Fan	2400 / 1800	23.5 / 17.4	57
	22 1/4"	17 5/8"	3"	16822	66822	A17 Powerpack, Single Fan	2400 / 1800	23.5 / 17.4	57
	22 1/2"	19"	4 1/2"	16830	66830	A11 Powerpack, Dual Fan	3750	18.7 Per Fan	59
	23 7/16"	15 7/16"	2 3/4"	16827	66827	A14 Powerpack, Single Fan	2100 / 1500	22 / 16.2	57
	23 3/4"	19 3/4"	4 1/2"	16835	66835	A11 Powerpack, Dual Fan	3750	18.7 Per Fan	57
	24"	15 1/2"	4 1/2"	16831	66831	A11 Powerpack, Dual Fan	3750	18.7 Per Fan	59
	24"	17"	3"	16828	66828	A17 Powerpack, Single Fan	2400 / 1800	23.5 / 17.4	57
24" - 34"	 24 3/4"	11 1/2"	3 1/4"	16812	---	A10 Powerpack, Dual Fans	1650	9.2 Per Fan	60
	25 5/8"	15 1/8"	4"	16825	66825	A12 Powerpack, Dual Fans	4000	24.8 Per	59
	25 5/8"	17 1/8"	4"	16826	66826	A12 Powerpack, Dual Fans	4000	24.8 Per Fan	59
	 26"	14"	3 3/4"	16850	66850	A12S Powerpack, Dual Fans	2675	14.2 Per Fan	60
	26"	18"	4"	16842	66842	A12 Powerpack, Dual Fans	4000	24.8 Per Fan	59
	26"	18"	4"	16927	66927	S12 Powerpack, Dual Fans	4000	24.8 Per Fan	59
	26 3/8"	16"	4"	16836	66836	A12 Powerpack, Dual Fans	4000	24.8 Per Fan	59
	27"	18"	4"	16837	66837	A12 Powerpack, Dual Fans	4000	24.8 Per Fan	59
	28 1/4"	17"	4"	16838	66838	A12 Powerpack, Dual Fans	4000	24.8 Per Fan	59
	28 5/8"	13 7/8"	3 1/4"	16928	---	M12 Powerpack, Dual Fans	4000	23.4 Per Fan	61
31 3/8"	15 3/4"	3 1/4"	16934	---	M12 Powerpack, Dual Fans	4000	23.4 Per Fan	61	
 31 1/2"	10 1/4"	3 1/4"	16839	---	A9S Powerpack, Triple Fans	2400	9.2 Per Fan	5	
 34"	17 1/4"	3 3/4"	16843	---	A17 Powerpack, Dual Fans	4800 / 3600	23.5 / 17.4	60	

Single Electric Fans - Quick Guide

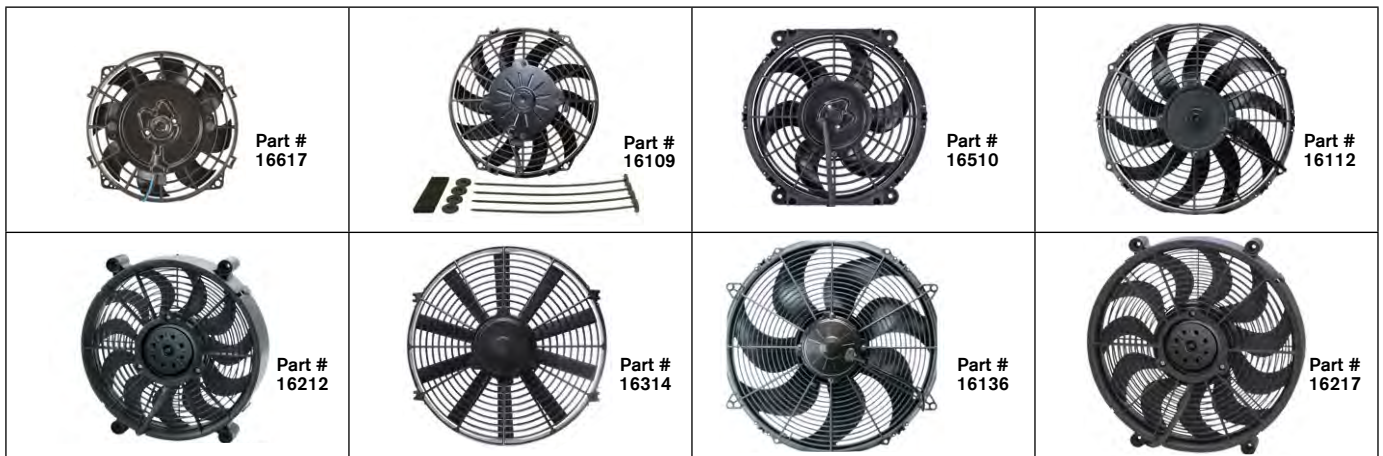

Fan Size	Overall Depth	Part No.	Airflow	CFM*	Amp Draw	Page
4"	2 3/8"	16104	Puller	125	1.9	63
5"	2 1/4"	16105	Puller	315	3.6	63
7"	2 3/8"	16507	Reversible	400	4.8	64
7"	2 3/8"	16617	Reversible	400	4.8	64
8"	2"	16108	Puller	366	5.5	63
8"	2 1/4"	16308	Puller	350	5.3	66
8"	2 1/4"	16908	Puller	350	5.3	66
8"	2 3/8"	16508	Reversible	500	4.8	64
8"	2 3/8"	16618	Reversible	500	4.8	64
9"	2"	16109	Puller	625	7.2	63
9"	2 1/4"	16309	Reversible	475	5.5	66
9"	2 1/4"	16909	Reversible	475	5.5	66
9"	2 1/2"	16509	Reversible	570	5.4	64
9"	2 1/2"	16619	Reversible	570	5.4	64
9"	3 3/4"	16119	Puller	755	10	63
10"	2 1/16"	16110	Puller	802	9.2	63
10"	2 1/2"	16010	Reversible	650	5.3	64
10"	2 3/8"	16310	Reversible	625	6.4	66
10"	2 3/8"	16910	Reversible	625	6.4	66
10"	2 3/8"	18910	Reversible	590	5.3	66
10"	2 1/2"	16510	Reversible	650	5.3	64
10"	2 1/2"	16620	Reversible	650	5.3	64
11"	4"	16920	Puller	1380	11	63
12"	2 3/8"	16912	Reversible	725	9	66
12"	2 3/8"	16312	Reversible	725	9	66
12"	2 3/8"	18912	Reversible	810	8.3	66
12"	2 1/2"	16622	Reversible	880	8.8	64
12"	2 1/2"	16512	Reversible	880	8.8	64
12"	2 1/2"	16012	Reversible	880	8.8	64

Fan Size	Overall Depth	Part No.	Airflow	CFM*	Amp Draw	Page
12"	2 5/8"	16212	Reversible	1450 / 1000	21 / 15	63
12"	2 5/8"	18212	Reversible	1450 / 1000	21 / 15	63
12"	2 7/16"	16112	Puller	1328	14.2	63
12"	3"	16925**	Reversible	2000	23.4	65
12"	3 1/2"	16918	Puller	1350	16	63
12"	3 1/2"	16924**	Reversible	2000	24.8	65
13"	3 3/4"	16142	Puller	1640	21.8	63
14"	2 5/8"	16214	Reversible	2100 / 1500	22 / 16.2	63
14"	2 5/8"	16913**	Reversible	2100 / 1500	22 / 16.2	65
14"	2 5/8"	18214	Reversible	2100 / 1500	22 / 16.2	63
14"	3 1/8"	18914	Reversible	1230	9.7	66
14"	3 1/4"	16014	Reversible	1350	10.5	64
14"	3 1/4"	16314	Reversible	1225	12.4	66
14"	3 1/4"	16514	Reversible	1350	10.5	64
14"	3 1/4"	16624	Reversible	1350	10.5	64
14"	3 1/4"	16914	Reversible	1225	12.4	66
14"	3 7/16"	16114	Puller	1864	21.5	63
16"	3 7/16"	16116	Puller	2024	21	63
16"	3 5/8"	18916	Reversible	1980	17.3	66
16"	3 3/4"	16136	Puller	1918	25.4	63
16"	3 7/8"	16916	Reversible	1680	15.5	66
16"	3 7/8"	16316	Reversible	1680	15.5	66
16"	4 1/8"	16016	Reversible	2175	18.4	64
16"	4 1/8"	16516	Reversible	2175	18.4	64
16"	4 1/8"	16626	Reversible	2175	18.4	64
17"	2 5/8"	16217	Reversible	2400 / 1800	23.5 / 17.4	63
17"	2 5/8"	16917**	Reversible	2400 / 1800	23.5 / 17.4	65
17"	2 5/8"	18217	Reversible	2400 / 1800	23.5 / 17.4	63

* CFM tested at zero static pressure. **Drop-in fans-Puller applications require shroud.



THE LEADER IN PERFORMANCE COOLING

PWM Electric Fan Controllers

Get Complete Control of Your Engine Temperatures

Historically, cooling fans run at 100%, even when less airflow is needed, constantly turning on and off as the engine temperature changes. This reaction based temperature control system causes constant amperage spikes, excessive noise and premature wear. The Derale PWM fan controller continuously monitors your engine's temperature, therefore controlling the temperature and increasing the vehicles cooling efficiency, while reducing the amps used to do so.

Here's how it works; The controller monitors your engine temperature via the cool side of the radiator, therefore providing a more accurate reading

for your cooling system. Using Soft Start Technology, fans ramp up slowly which eliminates harmful AMP spikes. The unit will continuously monitor your engine's temperature and operate the fans at the optimum fan rate as needed. The net result; the electric fans often only run between 40-60% to keep your engine cool. Additional benefits include, reduced fan speeds which means reduced fan noise, which tends to compete with that sweet sound of your engine!

Features and Benefits

- Soft Start Technology
- Multiple fan controller
- Reduced fan noise
- Constantly adjusts fans speed to maintain the desired temperature
- Pulse Width Modulation controls fan(s) speed from 0-100%
- Air conditioning override circuit built-in
- Includes all necessary installation hardware
- Includes auto resetting circuit breaker



- 70 AMP capacity
- 20 second cool down timer when vehicle is turned off
- New and improved digital design
- Maintains coolant temperatures from 130°F - 230°F
- Complete pre-wired wire harness
- Black anodized 6061 aluminum housing
- Built-in protections: Short circuit, Over amperage, Low voltage, High voltage, Reverse polarity, Over temperature & Anti flyback



- 65 AMP capacity
- Maintains coolant temperatures from 140°F - 220°F
- Powder coated die-cast aluminum housing
- US Patent 7006762

Part No.	Replacement Sensor	Dim A. (Width)	Dim B. (Height)	Dim C. (Depth)	Dim D. (Mounting)	Dim E. (Mounting)
16797	16757	5 13/16"	3"	1 5/8"	1 5/8"	5 1/8"

Part No.	Replacement Sensor	Dim A. (Width)	Dim B. (Height)	Dim C. (Depth)	Dim D. (Mounting)	Dim E. (Mounting)
16795	16757	4 1/2"	3 1/2"	2"	3"	3 1/4"

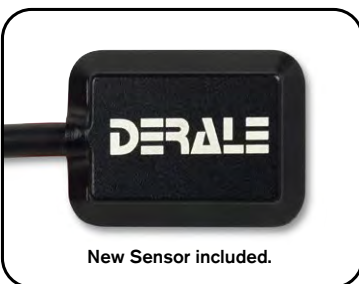

The NEW temp sensor Makes The PWM More Efficient Than Ever

The new temp sensor is changing the game for the PWM Electric Fan controller. After extensive research our product development team found a better way. The new temp sensor is designed for maximum efficiency. Its lean profile allows for an easy installation by using a Heavy Duty epoxy pad. Once in place, its light weight aluminum body reacts quickly to the radiator temperatures. This quick heat soaking action makes for an accurate temperature reading, crucial to keeping temperatures under control.

Dimensions

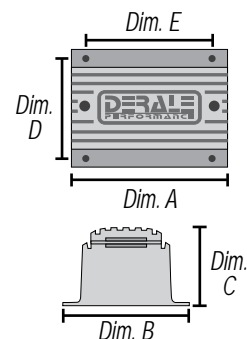

Electric Fan Controllers



THE LEADER IN PERFORMANCE COOLING



High Amp Adjustable Single Fan Controllers

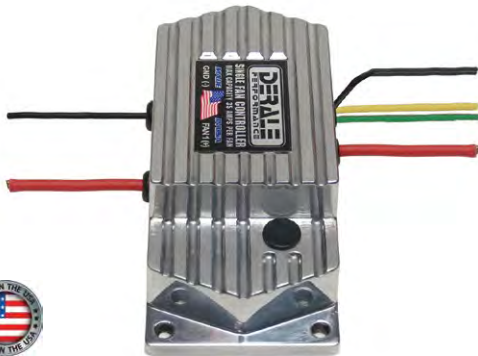

- 35 Amp Capacity
- Adjustable fan activation range from 150°F - 240°F
- Turn-off temperature preset at 15°F below activation setting
- Die Cast Aluminum housing with bright finish
- Automatic resetting circuit breaker
- Air conditioning override circuit built-in

Part No.	Application	Probe	Repl. Probe No.
16778	Single Fan	Push-In	16752
16779	Single Fan	3/8" NPT	16753

High Amp Adjustable Dual Fan Controllers

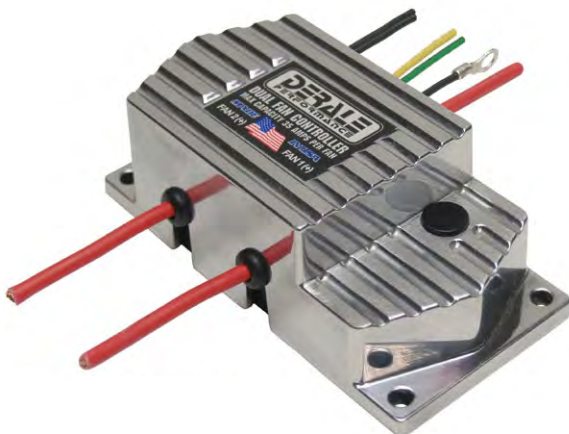

- 70 Amp Capacity (35 per fan)
- Adjustable fan activation range from 150°F - 240°F
- Activate Fan #1 at desired temp, activate fan #2 10°F warmer than fan #1
- Turn-off temperature preset at 10°F below activation setting
- Die Cast Aluminum housing with bright finish
- Automatic resetting circuit breaker
- Air conditioning override circuit built-in

Part No.	Application	Probe	Rep. Probe No.
16788	Dual Fan	Push-In	16752
16789	Dual Fan	3/8" NPT	16753



THE LEADER IN PERFORMANCE COOLING

Electric Fan Controllers

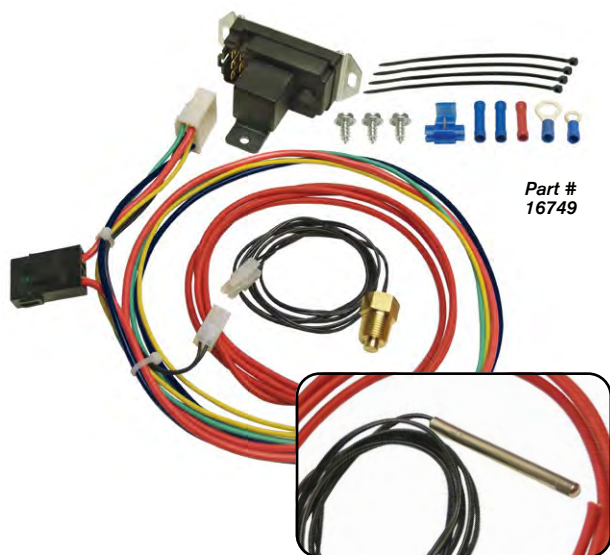

Part # 16759

Adjustable Fan Controllers

- 25 Amp Capacity
- Adjustable fan activation range from 150°F - 240°F
- Turn-off temperature preset at 10°F below activation setting
- Interchangeable probe design, push-in radiator or 3/8" NPT thread-in probe
- Air conditioning override circuit built-in

Part No.	Application	Probe	Rep. Probe No.
16749	Single Fan	3/8" NPT Thread in	16750
16759	Single Fan	Radiator Push-in	16760

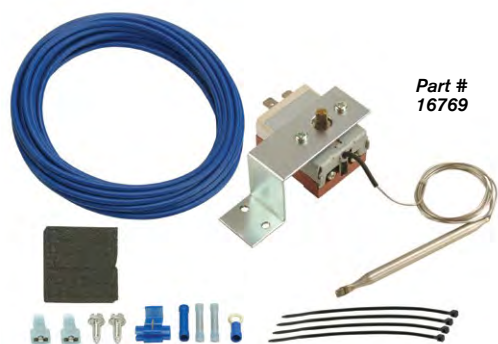

Part # 16769

Mechanical Fan Controller

- 16 Amp Capacity
- Adjustable fan activation range from 32°F - 240°F
- Turn-off temperature preset at 10°F below activation setting
- Radiator hose probe design

Part No.	Application	Probe
16769	Single Fan	Radiator Push-In



Part # 16720

Single Stage Fan Controllers

- Turn-off temperature preset at 15°F below activation setting
- Available in 180°F or 190°F Turn-on temperature
- Available in 15 or 25 amp capacity
- Available in push-in or thread-in probe
- 25 amp capacity kits include relay and harness



Part # 18739



Part # 16738

Part No.	Amp. Capacity	Probe	Temp Activation
16720	25 amp	Thread-In	180°F
16721	25 amp	Thread-In	190°F
16730	15 amp	Thread-In	180°F
16731	15 amp	Thread-In	190°F
16735	25 amp	Push-In / Thread-In	180°F
16738	25 amp	Push-In	180°F
16739	25 amp	Thread-In	180°F
18735	15 amp	Push-In / Thread-In	180°F
18738	15 amp	Push-In	180°F
18739	15 amp	Thread-In	180°F



THE LEADER IN PERFORMANCE COOLING

PERFORMANCE FUEL PUMPS



Universal Inline Fuel Pump Kits

- Compact design
- Constant high-flow rate
- Consistent pressure
- Rotary vane inline pump



Derale introduces its latest addition to its growing Performance Line-up. Our Universal Inline Fuel pumps are manufactured using only the highest quality materials, manufacturing methods and technology in order to insure maximum performance and reliability. These pumps cover a wide range of low pressure carbureted fuel system applications. They are also available for a variety of fuel types including Gasoline, Diesel, E85, E100, M100 and Racing Fuel. All Derale Universal Inline Fuel Pumps include the necessary hardware for installation as well as inline filters where applicable. Boost your fuel delivery system's efficiency and performance with our universal inline fuel pumps!



Part No.	Fuel Type	Flow rate	Max Pump Pressure
72000	Gasoline	130LPH	4-7 PSI
72001	Gasoline	100LPH	2-3.5 PSI
72003	Diesel	130LPH	4-7 PSI
72004	E85 / E100 / M100 / Racing Fuel	130LPH	4-7 PSI



THE LEADER IN PERFORMANCE COOLING

Belt Driven Fans



Features and Benefits

- Designed, engineered and manufactured in the USA
- Universal designs to fit most applications
- Model designs range from 13" to 20" diameters
- Most designs available in standard and reverse rotation

Dimensions

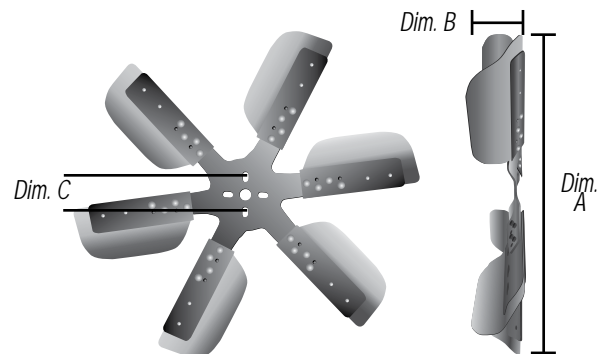



Chrome Hub

Black Hub



INCREASE FUEL ECONOMY



INCREASE HORSEPOWER & TORQUE

Heavy Duty Flex Fans

- Rated up to 10,000 RPM's
- Improves performance and mileage
- Large surface area pulls more air at low speeds
- Heavy duty steel hubs
- Durable stainless steel blades with built in Rebound Vipers
- Available in standard or reverse rotation



Standard Rotation



Reverse Rotation

Stainless Black Hub Part No.	Stainless Chrome Hub Part No.	Fan Size	Rotation	Dim. A (Diameter)	Dim. B (Depth)	Dia. C (Flange)
17013	17213	13"	Standard	13"	2"	1 3/4"-2 1/4"
17015	17215	15"	Standard	14 3/4"	2 7/8"	1 3/4"-2 1/4"
17017	17217	17"	Standard	17 1/4"	2 3/8"	1 3/4"-2 1/4"
17018	17218	18"	Standard	18 1/4"	2 7/16"	1 3/4"-2 1/4"
17019	17219	19"	Standard	19 1/4"	2 7/16"	1 3/4"-2 1/4"
17615	-----	15"	Reverse	14 3/4"	2 7/8"	1 3/4"-2 1/4"
17617	17817	17"	Reverse	17 1/4"	2 3/8"	1 3/4"-2 1/4"
17618	17818	18"	Reverse	18 1/4"	2 7/16"	1 3/4"-2 1/4"
17619	17819	19"	Reverse	19 1/4"	2 7/16"	1 3/4"-2 1/4"

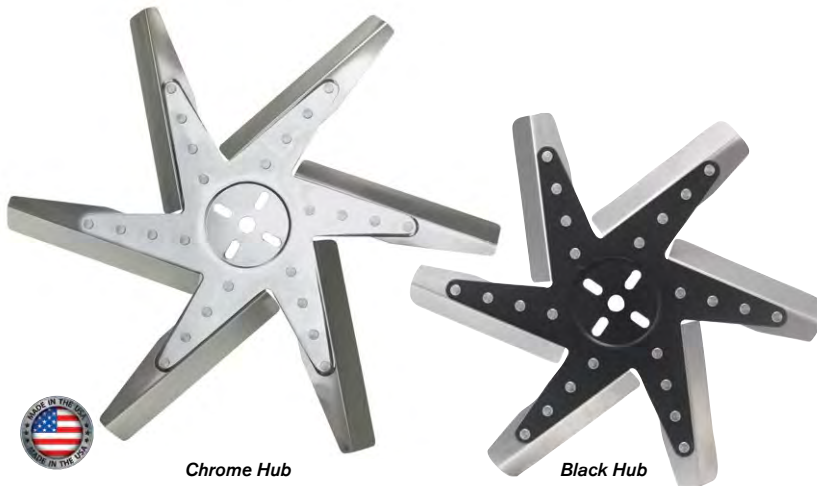

Chrome Hub

Black Hub



INCREASE FUEL ECONOMY



INCREASE HORSEPOWER & TORQUE

High Performance Stainless

- Rated up to 8,000 RPM's
- Stainless steel fan blades
- Chrome plated or black powder coated hub
- Available in standard or reverse rotation



Standard Rotation



Reverse Rotation

Stainless Black Hub Part No.	Stainless Chrome Hub Part No.	Fan Size	Rotation	Dim. A (Diameter)	Dim. B (Depth)	Dia. C (Flange)
19113	19213	13"	Standard	13 3/8"	1 1/8"	1 3/4"-2 1/4"
19115	19215	15"	Standard	15 1/4"	1 1/8"	1 3/4"-2 1/4"
19117	19217	17"	Standard	17"	1 1/8"	1 3/4"-2 1/4"
19118	19218	18"	Standard	18 1/4"	1 1/8"	1 3/4"-2 1/4"
19313	19713	13"	Reverse	13 3/8"	1 1/8"	1 3/4"-2 1/4"
19315	19715	15"	Reverse	15 1/4"	1 1/8"	1 3/4"-2 1/4"
19317	19717	17"	Reverse	17"	1 1/8"	1 3/4"-2 1/4"
19318	19718	18"	Reverse	18 1/4"	1 1/8"	1 3/4"-2 1/4"



Chrome Hub

Black Hub

High Performance Aluminum

- Rated up to 8,000 RPM's
- Red or Blue anodized aluminum fan blades
- Chrome plated or black powder coated hub
- Available in standard rotation



Black Hub Part No.	Chrome Hub Part No.	Fan Size	Rotation	Blade Color	Dim. A (Diameter)	Dim. B (Depth)	Dia. C (Flange)
19817	19417	17"	Standard	Red	17"	1 1/8"	1 3/4"-2 1/4"
19818	19418	18"	Standard	Red	18 1/4"	1 1/8"	1 3/4"-2 1/4"
19917	19517	17"	Standard	Blue	17"	1 1/8"	1 3/4"-2 1/4"
19918	19518	18"	Standard	Blue	18 1/4"	1 1/8"	1 3/4"-2 1/4"



Rigid Race Steel Blade Fans

- Rated up to 8,000 RPM's
- Steel fan blades
- Maximum full-time airflow
- Available in standard and reverse rotation

Standard Rotation Part No.	Reverse Rotation Part No.	Fan Size	Dim. A (Diameter)	Dim. B (Depth)	Dia. C (Flange)
17313	17413	13"	13"	2 1/4"	1 3/4"-2 1/4"
17315	17415	15"	15"	2 1/4"	1 3/4"-2 1/4"
17317	17417	17"	17"	2 1/4"	1 3/4"-2 1/4"
17318	17418	18"	18"	2 1/4"	1 3/4"-2 1/4"
17319	17419	19"	18 7/8"	2 1/4"	1 3/4"-2 1/4"
17320	17420	20"	19 7/8"	2 1/4"	1 3/4"-2 1/4"



Standard Rotation



Reverse Rotation



Rigid Race Aluminum Blade Fans

- Rated up to 8,000 RPM's
- Aluminum fan blades
- Maximum full-time airflow
- Available in standard rotation

Part No.	Fan Size	Rotation	Dim. A (Diameter)	Dim. B (Depth)	Dia. C (Flange)
17513	13"	Standard	13"	2 1/4"	1 3/4"-2 1/4"
17515	15"	Standard	15"	2 1/4"	1 3/4"-2 1/4"
17517	17"	Standard	17"	2 1/4"	1 3/4"-2 1/4"
17518	18"	Standard	18"	2 1/4"	1 3/4"-2 1/4"





Belt Driven Fan Spacers

- Strong one-piece aluminum construction
- Closed loop design
- Designed to fit 5/8", 3/4" or 1.180 water pumps
- Standard 5/8" male pilot
- Clear anodized finish
- Includes mounting hardware

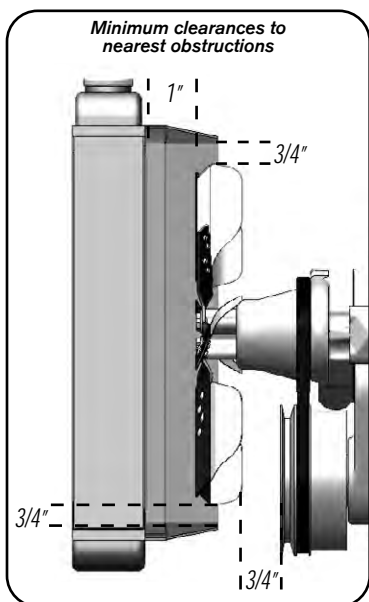
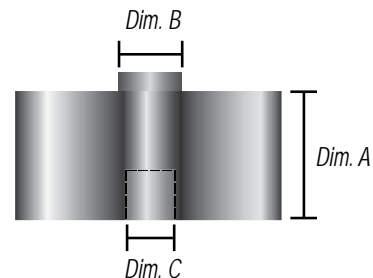

Part No.	Dim. A (Length)	Dim. B (Male Pilot Diameter)	Dim. C (Male Pilot Diameter)	Bolts (4 each)	Flange
31500	1/2"	5/8"	5/8"	5/16-18 / 5/16-24	1 3/4"-2 1/4"
31510	1"	5/8"	5/8" or 3/4"	5/16-18 / 5/16-24	1 3/4"-2 1/4"
31515	1 1/2"	5/8"	5/8" or 3/4"	5/16-18 / 5/16-24	1 3/4"-2 1/4"
31518	1 3/4"	5/8"	5/8" or 3/4"	5/16-18 / 5/16-24	1 3/4"-2 1/4"
31520	2"	5/8"	5/8" or 3/4"	5/16-18 / 5/16-24	1 3/4"-2 1/4"
31521	2"	5/8"	5/8" or 3/4"	8mm x 1.25	1 3/4"-2 1/4"
31540	2 1/4"	5/8"	5/8" or 3/4"	5/16-18 / 5/16-24	1 3/4"-2 1/4"
31541	2 1/4"	5/8"	1.180	8mm x 1.25	1 3/4"-2 1/4"
31547	2 1/4"	5/8"	5/8" or 3/4"	6mm x 1.00 / 8mm x 1.25	1 3/4"-2 1/4"
31550	2 1/2"	5/8"	5/8" or 3/4"	5/16-18 / 5/16-24	1 3/4"-2 1/4"
31551	3 1/2"	5/8"	1.180	8mm x 1.25	1 3/4"-2 1/4"

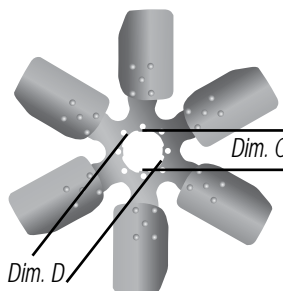

Mounting bolt circles:
3" and 3-1/4"

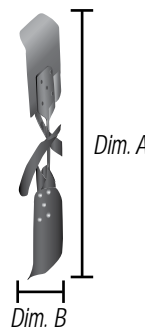

Fan Clutch Fans

- Rated up to 8,000 RPM's
- Steel fan blades
- Maximum full-time airflow
- Available in standard or reverse rotation
- Black powder coated finish



Standard Rotation Part No.	Reverse Rotation Part No.	Fan Size	Dim. A (Diameter)	Dim. B (Depth)	Dia. C (Flange)	Dia. D (Flange)
17117	17917	17"	17 1/4"	1 15/16"	2 3/8"	2 5/8"
17118	17918	18"	18"	1 15/16"	2 3/8"	2 5/8"
17119	17919	19"	19 1/8"	2 1/8"	2 3/8"	2 5/8"
17120	17920	20"	20"	1 15/16"	2 3/8"	2 5/8"

PART NUMBER INDEX



Part No.	Page	Part No.	Page	Part No.	Page	Part No.	Page	Part No.	Page
12006	45	13105	30	13403	22	15705	52	16114	67
12200	33	13106	30	13501	27	15706	52	16116	67
12213	33	13107	30	13502	27	15708	49	16119	67
12730	15	13108	30	13503	27	15709	49	16136	67
12731	15	13200	31	13504	27	15714	55	16142	67
12732	15	13210	32	13523	27	15715	47	16212	67
12733	15	13211	32	13611	25	15716	47	16214	67
12740	15	13212	31	13612	25	15717	47	16217	67
12741	15	13213	31	13613	25	15718	47	16308	70
12742	15	13215	27	13614	25	15719	16	16309	70
12743	15	13220	32	13615	25	15720	51	16310	70
12901	33	13221	32	13633	19	15721	17	16312	70
12902	33	13222	32	13700	13	15724	52	16314	70
12903	33	13223	32	13720	13	15725	47	16316	70
12904	33	13224	32	13730	14	15726	16	16507	68
12906	33	13225	32	13731	14	15728	49	16508	68
12907	33	13249	36	13735	16	15729	49	16509	68
13001	45, 71	13250	36	13740	9	15730	51	16510	68
13002	45	13251	36	13750	11	15731	51	16512	68
13003	45	13252	36	13751	11	15732	51	16514	68
13004	37	13253	36	13754	11	15733	51	16516	68
13005	49	13254	36	13760	9	15734	51	16617	68
13006	45	13255	36	13764	9	15735	51	16618	68
13007	45	13256	36	13870	9	15740	45	16619	68
13008	45	13257	36	13900	13	15746	52	16620	68
13010	59	13259	36	13950	11	15747	52	16622	68
13011	16	13260	36	13960	9	15748	47	16624	68
13014	37	13261	36	14000	59	15749	47	16626	68
13016	45	13262	36	14002	59	15751	45	16700	68
13017	45	13263	36	14010	59	15752	45	16701	68
13018	37	13264	36	14200	58	15755	52	16720	76
13021	17	13265	36	14201	58	15756	52	16721	76
13022	9, 11, 13	13266	36	14202	58	15757	52	16730	76
13023	9, 11, 13	13267	36	14204	58	15758	52	16731	76
13024	37	13269	35	14207	58	15761	52	16735	76
13025	37	13270	35	14208	59	15780	47	16738	76
13026	16	13271	35	14210	59	15781	47	16739	76
13028	37	13272	35	15200	13	15782	51	16740	71
13030	37	13277	35	15220	13	15799	45	16741	71
13031	37	13279	35	15230	14	15800	13	16742	71
13032	37	13280	35	15300	13	15820	13	16743	71
13033	37	13281	35	15301	29	15830	14	16744	71
13034	37	13282	35	15302	31	15831	14	16745	71
13035	37	13287	35	15320	13	15840	9	16746	71
13041	40	13300	13	15321	29	15845	9	16749	76
13042	40	13302	29	15331	29	15850	11	16750	76
13043	40	13303	30	15405	25	15851	11	16751	71
13044	40	13304	30	15450	11	15860	9	16752	75
13045	40	13306	30	15451	25	15865	9	16753	75
13046	40	13309	29	15500	13	15870	9	16754	71
13049	49	13310	29	15502	31	15875	9	16757	74
13062	45	13311	29	15503	31	15876	9	16759	76
13063	45	13312	29	15505	31	15900	13	16760	76
13064	45	13313	29	15551	31	15950	11	16763	71
13065	45	13314	29	15602	22	15960	9	16764	71
13070	54	13315	29	15603	22	16010	68	16765	71
13072	54	13316	29	15604	22	16012	68	16769	76
13075	54	13317	29	15605	22	16014	68	16778	75
13090	54	13318	29	15651	22	16016	68	16779	75
13091	54	13320	13	15660	9	16104	67	16788	75
13092	54	13322	29	15700	45	16105	67	16789	75
13101	30	13349	36	15701	45	16108	67	16795	74
13102	30	13350	36	15702	51	16109	67	16797	74
13103	30	13401	22	15703	52	16110	67	16812	64
13104	30	13402	22	15704	52	16112	67	16814	61



PART NUMBER INDEX

Part No.	Page	Part No.	Page	Part No.	Page	Part No.	Page	Part No.	Page
16816	61	17418	80	25708	49	35727	48	66819	61
16817	61	17419	80	25709	49	35728	48	66820	61
16818	61	17420	80	25719	16	35729	48	66821	61
16819	61	17513	80	25720	51	35747	52	66822	61
16820	61	17515	80	25728	49	35760	52	66823	61
16821	61	17517	80	25729	49	35762	52	66825	63
16822	61	17518	80	25730	51	35799	48, 40	66826	63
16823	61	17615	79	25731	51	35920	40	66827	61
16824	68	17617	79	25732	51	35921	40	66828	61
16825	63	17618	79	25733	51	35922	40	66830	63
16826	63	17619	79	25734	51	50020	23	66831	63
16827	61	17817	79	25750	49	50022	23	66833	63
16828	61	17818	79	25751	49	50023	23	66835	63
16830	63	17819	79	25752	49	50100	23	66836	63
16831	63	17917	81	25753	49	51006	21	66837	63
16833	63	17918	81	25770	51	51008	21	66838	63
16834	68	17919	81	25771	51	51010	21	66842	63
16835	63	17920	81	25772	51	51078	21	66927	63
16836	63	18212	67	25773	51	51606	21	72000	77
16837	63	18214	67	25774	51	51608	21	72001	77
16838	63	18217	67	25782	51	51610	21	72003	77
16839	5	18735	76	25783	51	51678	21	72004	77
16842	63	18738	76	25791	16	51906	21	96209	58
16843	64	18739	76	25792	16	51908	21	96900	58
16850	64	18910	70	31500	81	51910	21	96901	58
16908	70	18912	70	31510	81	51978	21	96905	59
16909	70	18914	70	31515	81	52506	21	96906	58
16910	70	18916	70	31518	81	52508	21	96908	59
16912	70	19113	79	31520	81	52510	21	98000	55
16913	69	19115	79	31521	81	52578	21	98003	52
16914	70	19117	79	31540	81	53406	21	98004	52
16916	70	19118	79	31541	81	53408	21	98020	55
16917	69	19213	79	31547	81	53410	21	98021	55
16918	67	19215	79	31550	81	53478	21	98028	55
16919	61	19217	79	31551	81	54006	21	98100	40
16920	67	19218	79	33501	27	54008	21	98101	40
16924	69	19313	79	33502	27	54010	21	98102	40
16925	69	19315	79	33503	27	54078	21	98103	40
16926	65	19317	79	33504	27	59006	40	98104	55
16927	63	19318	79	33523	27	59008	40	98105	55
16928	65	19417	80	33601	25	59010	40	98106	55
16934	65	19418	80	33602	25	59012	40	98200	40
17013	79	19517	80	33603	25	59106	40	98201	40
17015	79	19518	80	33604	25	59108	40	98202	40
17017	79	19713	79	33605	25	59206	40	98203	40
17018	79	19715	79	33633	19	59208	40	98204	40
17019	79	19717	79	35000	50	59210	40	98205	40
17117	81	19718	79	35020	17	59306	40	98206	40
17118	81	19817	80	35021	17	59308	40	98208	40
17119	81	19818	80	35022	17	59310	40	98233	55
17120	81	19917	80	35025	17	59406	40	98234	55
17213	79	19918	80	35026	17	59408	40	98244	55
17215	79	20161	5	35027	17	59506	40	98333	55
17217	79	20500	5	35030	5	59508	40	98334	55
17218	79	20541	4	35601	53	59510	40	98400	55
17219	79	20542	4	35611	53	59606	40	98410	55
17313	80	20543	4	35621	53	59608	40	98450	55
17315	80	20561	5	35703	52	59706	40	98451	55
17317	80	20565	5	35704	52	59708	40	98452	55
17318	80	25005	49	35705	52	61178	7		
17319	80	25011	16	35706	52	61878	7		
17320	80	25044	49	35707	48	65840	7		
17413	80	25049	49	35708	48	65860	7		
17415	80	25702	51	35709	48	65861	7		
17417	80	25707	49	35724	52	66818	61		

DERALE PERFORMANCE

3901 Medford St.
Los Angeles, CA 90063
Tel: (323) 266-3850
Fax: (323) 263-3948



Visit Us Online at:

DERALE.COM



20 21



Powered By

