

# **Dynatech**<sup>®</sup>

Competition Exhaust Systems

**HIGH PERFORMANCE, DRAG  
RACING, OVAL TRACK RACING**

[WWW.DYNATECHHEADERS.COM](http://WWW.DYNATECHHEADERS.COM)



**2020**  
MASTER **CATALOG**

# Dynatech®

**WHO WE ARE** Dynatech® continues to be the exhaust leader in all forms of racing and high performance applications. Advances in racing, engineering, and design have automakers bringing a whole new breed of cars and trucks to the streets and tracks. This same excitement and new wave of technology is apparent at Dynatech® as you view the pages of our latest catalog. We continue to be focused on new products and award-winning designs.



## WORLD CLASS DESIGN & ENGINEERING

Virtual reality exhaust design systems allow engineers to design the exhaust system in virtual space that will meet all necessary design criteria. Key interference and mounting points are captured and then transferred into engineering computer stations. Tube routings, lengths, and diameters can all be manipulated for proper fit and function. These processes cut design time by 90% and produce a much more efficient and powerful design.



## TECHNOLOGY & MANUFACTURING

At Dynatech®, we strive for 100% perfection on all of the products that we manufacture. Everything we manufacture goes through proven assembly steps and procedures to provide the end user with a product that we stake our reputation on. We have instituted numerous fitment and quality control inspections. All high performance systems are 100% tested to be leak free and 100% jig tested for fitment.



## UNMATCHED SALES & CUSTOMER SERVICE

Our team members are more than welders, machinists, engineers and salespeople. We are racers and enthusiasts just like you. We understand the needs of our customers and respond accordingly with outstanding technical support and customer service. In some cases, the very people that build the product speak with the end user. Fast and friendly service before, during and after the sale all come standard when you purchase Dynatech® products.



**VISIT US ONLINE**

***DynatechHeaders.com***

- SHOP THE ONLINE STORE
- WATCH TUTORIALS
- REVIEW PRODUCT TECH



# CONTENTS

## 2020 DYNATECH® CATALOG

★★★★★ SUPERIOR PRODUCTS

Dynatech® products provide superior performance and fit for a wide range of exhaust applications. One thing that you can always count on regardless of what Dynatech® product you buy is excellent fit, function and performance. We understand the value of offering no hassle, maintenance-free products to our customers.

5

### DRAG RACING

#### Headers

Dragster / Strut Front Headers	06
Weld-up / Strut Front Header Kits	09
Camaro / Nova Headers	10
<i>Standard / Tall Deck Headers</i>	
Mustang K-Member Headers	11
Mufflers & Collectors	12
Exhaust Accessories	14

19

### MUSCLE CAR

#### Headers

'67-'69 Camaro Headers	20
'68-'74 Nova Headers	22
'70-'81 Camaro Headers	24
Block Hugger Headers	25

26

### HIGH PERFORMANCE

#### Headers

'18-'19 Ford Mustang GT	29
'15-'17 Ford Mustang Shelby GT350 Headers	30
'11-'17 Ford Mustang 5.0	31
'07-'14 Ford Mustang Shelby GT500 Headers	32
'05-'10 Ford Mustang GT Headers	33
'05-'17 Challenger / Charger / Magnum Headers	34
'14-'18 C7 / Z06 Chevy Corvette Headers	35
'05-'13 C6 / Z06 Chevy Corvette Headers	36
'97-'04 C5 Chevy Corvette Headers	37
'09-'15 Cadillac CTS-V Headers	38
'16-'17 Chevy Camaro SS / ZL1 Headers	39
'10-'15 Chevy Camaro Headers	40
'98-'02 Chevy Camaro / Trans Am	41
Exhaust Accessories	42

45

### TRUCK / SUV

#### Headers

'15-'17 Ford F-150	47
'11-'14 Ford F-150	48
'04-'08 Ford F-150 Truck Headers	49
'99-'03 Ford F-150 Truck Headers	50
'99-'04 Ford Lightning	50
'14-'19 Chevy / GMC Truck / SUV Headers	51
'07-'13 Chevy 1500 Truck / SUV Headers	52
'99-'06 Chevy 1500 Truck / SUV Headers	53
'00-'09 Hummer H2 Headers	54
'04-'05 Dodge 1500 Truck Headers	55

56

### OVAL TRACK

#### Headers

Crate Modified Headers	58
Modified Headers	59
Dirt Late Model Headers	60
Exhaust Accessories	61

### Apparel & More

AFCO Performance Group Apparel	62
--------------------------------	----

## FEATURES & BENEFITS

# WHAT IS IN A QUALITY SYSTEM?



**CNC LASER-CUT  
FLANGES**



**EQUAL LENGTH  
PRIMARY TUBES**



**FIBER  
GASKETS**

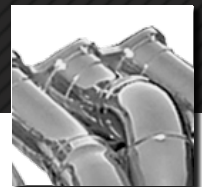

**360° GUSSET  
SUPPORTS**

**PERFECT, DIRECT BOLT-ON FIT**

**100%** JIG ASSEMBLED AND CHECKED  
FOR AN EXCELLENT FIT

**OPTIMIZED TUBE LENGTH**  
FOR INCREASED H.P. AND TORQUE

**CERAMIC COATED FINISH**

**ALL FLANGES**



MACHINE SURFACED  
AFTER WELDING

**MADE IN THE U.S.A.**

**ONE YEAR  
LIMITED  
WARRANTY**

AFCO Performance Group, LLC will repair or replace any products found upon our inspection to be defective in workmanship or material within 12 months from date of purchase for the original purchaser. Except for the limited warranty set forth herein, AFCO Performance Group, LLC makes no warranties either expressed or implied, written or oral, with regard to the products including, without limitation, any warranty of merchantability or fitness for a particular purpose. In no event shall AFCO Performance Group, LLC be liable for any special, incidental or consequential damages, or any other damages whatsoever arising out of or connected with the use or misuse of the products. Purchasers acknowledge and agree that no person, entity or agent of AFCO Performance Group, LLC has any authority to make any statement contrary to this disclaimer and that any warranty statements or representations allegedly made on behalf of AFCO Performance Group, LLC by any such person, entity or agent are void. AFCO Performance Group, LLC products are not D.O.T. approved or intended for street use. Purchasers are relying solely on their own skill and judgment to select, purchase and use suitable products and assume all responsibility and risk with regard thereto.





# DRAG RACING

*We have taken out all the guess work when it comes to selecting the right header for your race car. Dynatech® Drag Racing Headers are purpose-built to fit your specific application.*



*TIG-welded flanges are accurate to +/- .003" and improve weld flow for increased durability.*

*360° Gusset supports increase durability for muffler applications.*

*All drag headers are Chrome or high-temperature, silver ceramic coated inside and out.*

*Jig located U-tabs for easy bolt on collector installation.*



# DRAG RACING

## 2<sup>STEP</sup> DRAGSTER **CHROME** HEADERS TWO-STEP VERSION

- Large radius, CNC mandrel bent, equal length primary tubes.
- Equal length for superior acceleration.
- 360° gusset supports increased durability.
- CNC laser-cut flanges for superior quality and accuracy.
- Broader performance range with a combination of two tube sizes.
- A great combination of low end Tq and high end Hp over a non-stepped header.



\*Pan E-vac/O2 Kit included with all Standard Collectors.  
785-10095

**1 YEAR LIMITED WARRANTY**  
**MADE IN THE U.S.A.**

APPLICATION	TUBE SIZE	PART #	PRICE
CHROME DRAGSTER W/ STANDARD 4.500" COLLECTORS (2 STEP)*	2.250" - 2.375"	750-96410	\$1499.99
CHROME DRAGSTER W/ STANDARD 4.500" COLLECTORS (2 STEP)*	2.375" - 2.500"	750-98410	\$1499.99
CHROME DRAGSTER W/ 4.500" MERGE COLLECTORS (2 STEP)	2.250" - 2.375"	750-97410	\$1699.99
CHROME DRAGSTER W/ 4.500" MERGE COLLECTORS (2 STEP)	2.375" - 2.500"	750-99410	\$1699.99





## LONG TUBE BIG BLOCK CHEVY SIDE EXIT HEADER KIT

These Long Tube Big Block Chevy Header kits are designed with ease of assembly and performance in mind. The tubes are tack welded together to make it easy to completely assemble or make changes. Collectors are sold separately and come in a variety of sizes in standard or merge style configurations. Optional ceramic coating is available once you assemble your kit. After assembly, the 16 gauge steel construction and CNC laser-cut, surfaced flanges make this a durable header for multiple racing seasons.

- 0.375" thick CNC laser cut and surfaced flanges.
- Stepped tube sizes to optimize torque and horsepower.
- Designed to run out the side fender of a tube chassis door car with a BBC.
- 28.000" primaries.
- **Collectors sold separately (page 13).**



APPLICATION	TUBE SIZE	PART #	PRICE
SIDE EXIT HEADER KIT	2.250" - 2.375"	760-42410	\$499.99
SIDE EXIT HEADER KIT	2.375" - 2.500"	760-44410	\$499.99
SIDE EXIT HEADER KIT (14° HEAD)	2.250" - 2.375"	760-46410	\$499.99
SIDE EXIT HEADER KIT (14° HEAD)	2.375" - 2.500"	760-47410	\$499.99



DON O'NEAL

# DRAG RACING

## HEADERS SLIP-ON COLLECTORS

**1 YEAR LIMITED WARRANTY**  
**MADE IN THE U.S.A.**

**DRAGSTER, BIG BLOCK CHEVY, STRUT FRONT & DOOR SLAMMER**

- CNC laser cut flanges feature raised port location for increased power.
- Unique port gussets eliminate cracking caused by tire shake and muffler applications.
- Jig located U-tabs for hassle free, bolt-on collectors.
- Five models in straight or stepped header tubes.
- 28.000" equal length design.
- High-temp., silver ceramic coated inside and out. Ceramic coating comes with a three year limited warranty.



**Ceramic Coated**



\*Pan E-vac/O2 Kit included with all Standard Ceramic Collectors. (Collectors sold separately)

**\$799.99**  
**HEADERS ONLY**

**\$159.99**  
each  
**STANDARD COLLECTOR (COATED)\***

APPLICATION	TUBE SIZE	PART #	+	PART # / OUTLET SIZE
STRUT TYPE, DRAGSTER	2.250"	750-91410		783-71241 (4.000")
STRUT TYPE, DRAGSTER	2.250" - 2.375"	750-92410		783-81241 (4.000") 783-81246 (4.500")
STRUT TYPE, DRAGSTER	2.375" - 2.500"	750-94410		783-91246 (4.500")



## WELD-UP HEADER KITS

### BIG BLOCK CHEVY STRUT FRONT AND DRAGSTER HEADERS

Designed specifically for strut type front end cars and dragsters, this kit allows you to fabricate your own headers to save money or make changes to the kit to fit your specific needs. These kits are assembled in the same jig we use for our finished headers. Then, we simply tack-weld all connections. If needed, you can cut a tack-weld to reposition the tube, or you can simply finish weld the kit and have the same header offered by Dynatech®.

- Same exact header as a Dynatech® finished header.
- Tack-welded to make it easy to change or finish weld.
- CNC laser-cut flanges, gaskets, gussets and bolts included.
- Optimum port exit angle for added power.
- **Collectors must be purchased separately (see below.)**
- **Star Plugs must be purchased separately (see page 13.)**

#### BIG BLOCK DRAGSTER/STRUT TYPE HEADERS

TUBE SIZE	HEADER KIT	PRICE
2.250"	760-91410	\$429.99
2.250" - 2.375"	760-92410	\$429.99
2.375"	760-93410	\$429.99
2.375" - 2.500"	760-94410	\$429.99
2.500"	760-95410	\$429.99

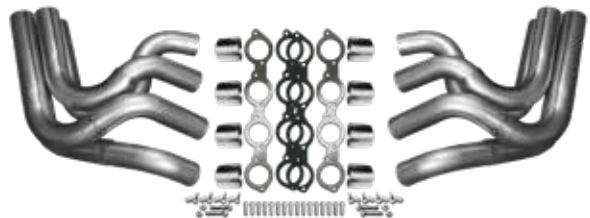

#### STANDARD COLLECTOR

TUBE SIZE	OUTLET SIZE	PART#	PRICE
2.000"	3.500"	783-51235	\$99.99
2.250"	4.000"	783-71240	\$99.99
2.375"	4.500"	783-81245	\$99.99
2.500"	4.500"	783-91245	\$99.99
2.500"	5.000"	783-91250	\$99.99



#### MERGE COLLECTOR

TUBE SIZE	OUTLET SIZE	PART#	PRICE
2.250"	4.000"	780-02518	\$199.99
2.375"	4.500"	780-03519	\$199.99
2.500"	4.500"	780-03510	\$199.99

Note: Does not include O2 bungs. To purchase separately please order: **785-10097** (pg. 16).

#### BIG BLOCK

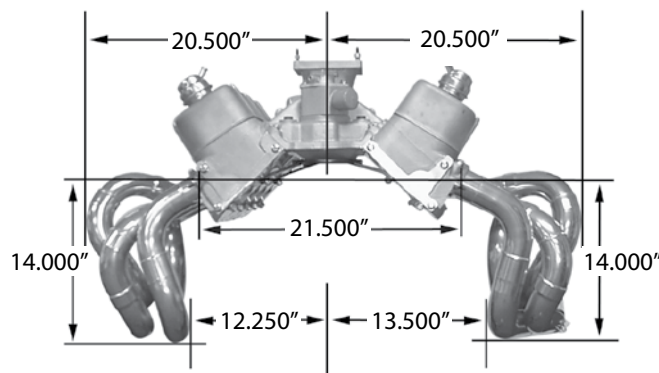

# DRAG RACING

## DRAG RACING EXHAUST BIG BLOCK CHEVY STD. & TALL DECK "572"

**1 YEAR LIMITED WARRANTY**  
**MADE IN THE U.S.A.**

**'67 – '69 CAMARO**  
**'68 – '74 NOVA**

**▶ COATED**

- Designed for BBC tall deck motors.
- Mandrel bent 2.125" primary tubes.
- CNC laser-cut flanges feature optimum port location for increased power.
- Designed for stock engine location.
- Fits factory, manual, and power steering box.



\*Pan E-vac/O2 Kit included with all Standard Coated Collectors.

- High-temp., silver ceramic coated inside and out.
- Ceramic coated headers require separate purchase of collectors.
- 10.200" Deck height.



**\$159.99**  
**STANDARD COLLECTOR (COATED)\***

**HEADERS ONLY**

APPLICATION	TUBE SIZE	PART #	PRICE	OUTLET SIZE	PART #
BBC GM 572 TALL DECK	2.125"	750-91010	\$839.99	3.500"	783-61236
				4.000"	783-61241



**'67 – '69 CAMARO**  
**'68 – '74 NOVA**

**▶ PAINTED**

- Painted headers come with collectors installed.
- Reducer kit included.
- Built for use with the factory subframe.
- Fits around Manual and Power Steering boxes as well as factory A/C boxes and factory power brake booster.
- Fits Automatic or 4 speed.
- Ceramic coating services are available. Call for details.



Black Painted  
750-91910 shown

APPLICATION	TUBE SIZE	PART #	PRICE	OUTLET SIZE
BBC GM 572 TALL DECK (PAINTED) 10.2" DECK HEIGHT	2.125"	750-91910	\$699.99	3.500"
BBC GM STANDARD DECK (PAINTED) 9.8" DECK HEIGHT	2.125"	740-59310	\$599.99	3.500"



## MUSTANG K-MEMBER HEADERS '79 - '04 MUSTANGS

- For use with AJE, TEAMZ, and P.A. Racing K Members.
- Fits with factory starter, master cylinder, brake booster & proportioning valve (SBC, SBF, LSX only).
- Designed to be used with a wide variety of transmissions.
- '79-'93 requires after market steering shaft.
- May require a "cable style" shifter linkage.
- Not designed for use with motorplate.



**1 YEAR LIMITED WARRANTY**  
**MADE IN THE U.S.A.**



**LSX**

'79 - '93 w/ LS Based Chevy: 1.875" Tube w/ 3.000" Collector

715-91410

\$599.99

'94 - '04 w/ LS Based Chevy: 1.875" Tube w/ 3.000" Collector

715-91310

\$599.99



**SBC**

**\$599.99**

**SMALL BLOCK CHEVY:**

1.750" - 1.875" Tube

3.000" Collector

701-23010



**BBC**

**\$699.99**

**BIG BLOCK CHEVY:**

2.125" Tube

3.500" Collector

750-91110



**SBF**

**\$599.99**

**351 WINDSOR & 302\*:**

1.750" - 1.875" Tube

3.000" Collector

704-23010

*\*Will work with 302 by spacing engine up 0.625" between engine block and motor mount.*

## MUFFLERS

### Auger Style Muffler



- 11.000" long – fits inside 3.000" or 3.500" O.D. pipe.
- Weighs only 1.000 lb.
- 6-7 dB reduction.

APPLICATION	SIZE	PART #	PRICE
AUGER STYLE MUFFLER	3.000"	776-24302	\$29.99
AUGER STYLE MUFFLER	3.500"	776-24352	\$29.99

## SPLIT-FLOW<sup>®</sup> RACING MUFFLERS

The Split-Flow<sup>®</sup> racing muffler is the "hot topic" among racers, and for good reason. The straight-thru design can handle big power. The exclusive dual pattern core reduces dB levels while maintaining a powerful sound. The all-aluminized, fully welded construction makes it a top choice for racing and high performance applications.

- Straight-thru design for maximum flow.
- Dual-pattern core for reduced sound levels.
- All-aluminized materials and welded construction.
- Stainless steel sound absorbing material for no burnout.
- Lightweight design.
- Meets or exceeds dB requirements at most muffler-required sanctioned events.

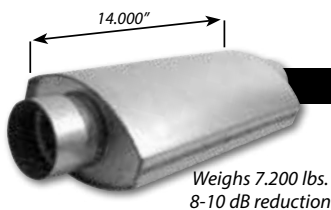
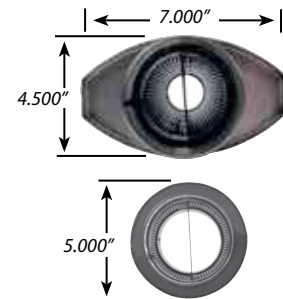

OVAL (14.000"L X 7.000"W X 4.500"H DIA.)	INLET I.D.	OUTLET I.D.	PART #	PRICE
SPLIT-FLOW <sup>®</sup> OVAL	2.500"	2.500"	776-14252	\$139.99
SPLIT-FLOW <sup>®</sup> OVAL	3.000"	3.000"	776-14302	\$139.99
SPLIT-FLOW <sup>®</sup> OVAL	3.500"	3.500"	776-14352	\$149.99

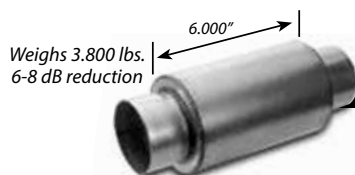

ROUND (6.000"L X 5.000" DIA.)	INLET I.D.	OUTLET I.D.	PART #	PRICE
SPLIT-FLOW <sup>®</sup> ROUND	3.000"	3.000"	776-06302	\$119.99
SPLIT-FLOW <sup>®</sup> ROUND	3.500"	3.500"	776-06352	\$119.99

## STANDARD COLLECTORS

Dynatech® slip-on race collectors offer great performance at an affordable price. All collectors come race-ready right out of the box. They are available in a wide variety of primary tube and collector outlet sizes for all popular applications.

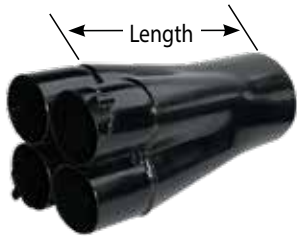

### PAINTED MILD STEEL SLIP-ON COLLECTORS

TUBE SIZE	OUTLET SIZE	LENGTH	PART#	PRICE
1.750"	3.000"	12.000"	783-31230	\$99.99
1.875"	3.000"	12.000"	783-41230	\$99.99
1.875"	3.500"	12.000"	783-41235	\$99.99
2.000"	3.500"	12.000"	783-51235	\$99.99
2.125"	3.500"	12.000"	783-61235	\$99.99
2.250"	4.000"	12.000"	783-71240	\$99.99
2.375"	4.500"	12.000"	783-81245	\$99.99
2.500"	4.500"	12.000"	783-91245	\$99.99
2.500"	5.000"	12.000"	783-91250	\$99.99



### CERAMIC COATED MILD STEEL SLIP-ON COLLECTORS

TUBE SIZE	OUTLET SIZE	LENGTH	PART#	PRICE
2.125"	3.500"	12.000"	783-61236	\$159.99
2.125"	4.000"	12.000"	783-61241	\$159.99
2.250"	4.000"	12.000"	783-71241	\$159.99
2.375"	4.000"	12.000"	783-81241	\$159.99
2.375"	4.500"	12.000"	783-81246	\$159.99
2.375"	5.000"	12.000"	783-81251	\$159.99
2.500"	4.500"	12.000"	783-91246	\$159.99



\*Pan E-vac/O2 Kit included with all Standard Collectors.



Required when using non-slip-on/weld-on collectors.



### STAR PLUGS

TUBE SIZE	PART#	PRICE
SMALL UP TO 2.250" TUBE SIZE	794-00012	\$2.99
X-LARGE 2.375" TUBE SIZE AND UP	794-00022	\$2.99



### COLLECTOR SPIKE/GOILET

COLLECTOR SPIKE	PART#	PRICE
COLLECTOR SPIKE	550000620	\$9.99



# ACCESSORIES

## MERGE COLLECTORS

In order to understand how the merge collector works, you must first know why one exhaust system can generate more torque and horsepower than another. The ability of a header/exhaust system to maintain exhaust gas velocity has a tremendous impact on realizing maximum torque and horsepower. Any significant changes in the system, such as baffles (mufflers) or collectors, will have an impact on exhaust gas velocity. The large area change seen at the transition from the primary tube to the collector causes an immediate reduction in exhaust gas speed. This reduction in speed decreases the efficiency of the system, thereby reducing scavenging ability. Scavenging ability is the key factor by which an exhaust system is evaluated. The more efficient the system, the more air/fuel mixture that can be pulled into the combustion chamber. Obviously, the greater quantity of air/fuel mixture that can be burned, the more torque and power potential the engine has.

The construction of a merge collector is such that the change in area at the primary tube to collector transition point is minimized. This gradual transition allows the exhaust gas to maintain as much velocity as possible. Maintaining gas velocity is the key to allowing the exhaust system to reach its efficiency potential.

Merge collectors significantly improve the efficiency of the exhaust system. If your combination has been optimized to a header with standard collectors, it's possible to over-scavenge when adding merge collectors. Over-scavenging will normally decrease torque and horsepower when compared to your optimized, previous setup. We recommend dyno testing to arrive at the final camshaft combination when using this style of collector. If you need that last little edge and are willing to do the testing required to realize the potential gains, merge collectors are one of the most economical ways to gain significant amounts of torque and horsepower in the entire engine combination.

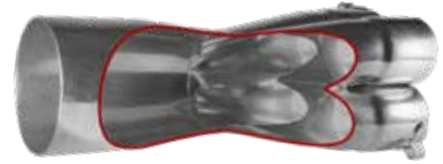

- 100% TIG-welded.
- Optimum reduction angle.
- Increases torque and horsepower.
- Sold Individually.

Note: Does not include O2 bungs. To purchase separately please order: **785-10097** (pg. 16).

### Mild Steel Merge Collectors

SLIP OVER	OUTLET	PART #	PRICE
2.250"	4.000"	<b>780-02518</b>	\$199.99
2.375"	4.500"	<b>780-03519</b>	\$199.99
2.500"	4.500"	<b>780-03510</b>	\$199.99

## INSERT CONES

### VORTEX® INSERT CONE

**NEW LOWER PRICING!**

- 100% T-304 stainless steel construction.
- Ultra-lightweight, less than .500 lbs. each.
- Little or no power loss.
- Easy bolt-in installation.

### HOW IT WORKS:

The Vortex® Insert Cone, installed near the exit of the header collector or muffler outlet, provides a large friction area to reflect and dissipate sound energy, thus reducing the dB level. The open area of the cone is actually greater than the area of the collector or exhaust pipe, thus reducing a back pressure condition. Because no significant back pressure has been introduced, the engine is still able to use the scavenge ability of a good header to create horsepower and torque. Dyno and track testing show significant noise reduction with little or no power loss.



TUBE SIZE	A	B	PART #	PRICE
3.000"	3.750"	1.000"	<b>772-32520</b>	\$69.99
3.500"	4.750"	1.000"	<b>772-32510</b>	\$69.99
4.000"	6.250"	1.000"	<b>772-32530</b>	\$69.99
4.500"	6.750"	1.000"	<b>772-32540</b>	\$69.99

Weighs less than 1/2 lbs. 1-3 dB reduction.

## TURN DOWNS WITH CONES

The Vortex® Turn Down is expanded to slip over collector outlets or tail pipes. Greater sound reduction can be achieved by directing the outlet away from the meter or sound test point. U-tab mounting hardware is included.



DESCRIPTION	TUBE SIZE	PART #	PRICE
TURN DOWN WITH 3.000" CONE INSTALLED	3.000"	<b>780-01100</b>	\$119.99
TURN DOWN WITH 3.500" CONE INSTALLED	3.500"	<b>780-01200</b>	\$119.99

CONES ARE SOLD INDIVIDUALLY, TWO REQUIRED PER V-8 ENGINE.

# FLANGES & GASKETS

## MUSCLE CAR APPLICATIONS

A great exhaust system starts at the beginning — the flange. One of Dynatech®'s biggest advantages is our wide selection of port matched flanges. All of our flanges are CNC laser cut for unparalleled quality and fit.



Mild Steel Flanges



Fiber Gasket

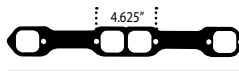
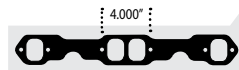

**DESCRIPTION**

- SMALL BLOCK CHEVY 23°
- SMALL BLOCK CHEVY 23°
- SMALL BLOCK CHEVY 23°
- SMALL BLOCK CHEVY 23°
- SMALL BLOCK CHEVY 18°
- LS1 GM
- STAHL ROUND PATTERN
- SPREAD PORT CHEVY
- SPREAD PORT CHEVY
- SPREAD PORT CHEVY
- BIG BLOCK CHEVY
- BIG BLOCK CHEVY
- BIG BLOCK CHEVY
- BIG BLOCK CHEVY

Starting at: **\$29<sup>99</sup>**

**FLANGE**  
*(single)*

PORT	X	Y	THICKNESS
1.750"	1.485"	1.880"	.375"
1.625"	1.485"	1.685"	.375"
1.625"	1.485"	1.685"	.250"
1.750"	1.485"	1.880"	.250"
1.875"	1.839"	1.697"	.3125"
1.875"	1.946"	1.946"	.3125"
1.875"	1.944"	1.944"	.3125"
1.875"	1.950"	1.950"	.3125"
2.000"	2.070"	2.070"	.3125"
-	2.125"	2.196"	.3125"
2.125"	2.224"	2.224"	.3125"
2.250"	2.350"	2.350"	.375"
2.375"	2.476"	2.476"	.375"
2.500"	2.600"	2.600"	.375"

Starting at: **\$19<sup>99</sup>**

**GASKET**  
*(pair)*

794-00001
794-00001
794-00001
794-00001
-
794-20001
-
794-00000
794-00000
794-00000
794-50011
794-50001
794-50001
794-50001

## CERAMIC COATING

All headers purchased with this option are coated inside and outside. The coating will significantly reduce the underhood temperature of your car — which translates into horsepower gain. **Headers purchased with this ceramic coating come with a 3 year warranty and a customer satisfaction guarantee.**

DESCRIPTION	PART#	PRICE
CERAMIC COATING FOR HEADERS	790-00100	\$299.99
CERAMIC COATING FOR X & Y PIPES	790-00101	\$74.99
CERAMIC COATING FOR ELBOWS	790-00102	\$49.99
CERAMIC COATING FOR COLLECTORS	790-00103	\$68.99

Note: Ceramic coating not available for Catalytic converters.

# ACCESSORIES

## CLAMP COLLAR KIT



These clamp collar kits allow you to connect extension pipes, Y-pipes, X-pipes, and mufflers without welding. The clamps also allow you to quickly disconnect if needed.

DESCRIPTION	TUBE SIZE	PART#	PRICE
CLAMP COLLAR KIT	2.500"	794-90250	\$29.99
CLAMP COLLAR KIT	3.000"	794-90200	\$29.99
CLAMP COLLAR KIT	3.500"	794-90350	\$29.99
CLAMP COLLAR KIT	4.000"	794-90400	\$29.99

## O2/PAN E-VAC KIT

Complete kit w/ weld-on bung.

- Increase horsepower.
- Better ring seal.
- Reduce crankcase pressure.



This kit has been dyno-proven to pull as much as 3 inches of vacuum on your typical bracket engine. The U-weld kit features an 18mm threaded bung that will also accept a standard O2 sensor found on EFI applications. Threaded adapter has standard .500" mpt for typical valve cover plumbing installation. 1-kit required per collector.

DESCRIPTION	PART#	PRICE
O2 SENSOR/PAN E-VAC COMPLETE KIT	785-10095	\$26.99
18MM WELD ON BUNG	785-10097	\$7.99
O2/E-VAC MALE ADAPTER	785-10096	\$11.99
18MM PLUG	785-10094	\$6.99
18MM SEALING WASHER	785-10093	\$6.99

## V-CLAMP KITS



Kit includes two weld-on v-clamp rings and stainless steel v-band clamp. Models for 2.500", 3.000", or 3.500" pipe sizes.

DESCRIPTION	PART#	PRICE
V-CLAMP COLLAR ASSEMBLY 2.500"	794-91225	\$49.99
V-CLAMP COLLAR ASSEMBLY 3.000"	794-91230	\$49.99
V-CLAMP COLLAR ASSEMBLY 3.500"	794-91235	\$59.99

## HEADER BOLT KITS

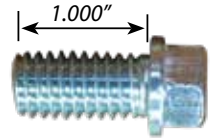

DESCRIPTION	THREAD	PART#	PRICE
12 POINT HEAD	3/8-16	794-00120	\$6.99
HEX BOLTS (16 PACK)	3/8-16	794-00118	\$7.99

## MANDREL BENT J-BENDS

Dynatech® stocks a complete inventory of mandrel bent J-bends. These are made from premium grade mild steel tubing.

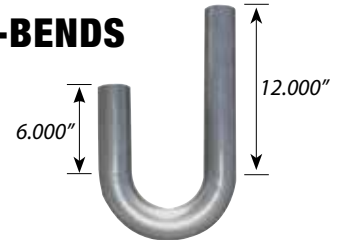

SIZE	CLR	MILD STEEL		STAINLESS	
		PART#	PRICE	PART#	PRICE
1.625"	2.625"	794-60202	\$24.99	794-60302	\$29.99
1.750"	2.625"	794-60203	\$24.99	-	-
2.000"	3.000"	794-60205	\$24.99	-	-
2.125"	3.188"	794-60206	\$24.99	-	-
2.250"	3.375"	794-60207	\$24.99	-	-
2.325"	3.563"	794-60208	\$29.99	-	-
2.500"	3.750"	794-60209	\$29.99	-	-

## U-TAB KIT



These are the same U-tabs we use on all Dynatech® headers and collectors. Kit includes: U-tabs and hardware.

DESCRIPTION	PART#	PRICE
U-TAB KIT (2 TABS, 1 BOLT)	794-00310	\$9.99
U-TAB KIT (4 TABS, 2 BOLTS)	794-00313	\$19.99
U-TAB KIT (8 TABS, 4 BOLTS)	794-00320	\$19.99

## EXTENSIONS

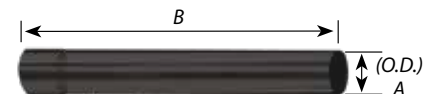

- Manufactured from mild steel.
- Designed to slip over 3.000" or 3.500" outer diameter on one end.
- Ideal for finishing your exhaust system.

"A"	"B"	PART#	PRICE
3.500"	24.000"	780-00301	\$34.99
3.000"	24.000"	780-00302	\$34.99



# ACCESSORIES

## EXHAUST ELBOWS

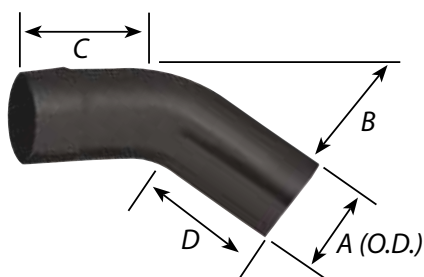

"A"	"B"	"C"	"D"	PART#	PRICE
3.000"	30°	6.000"	6.000"	780-30301	\$29.99
3.500"	30°	6.000"	7.000"	780-30351	\$29.99
3.000"	42°	6.000"	12.000"	780-42301	\$29.99
3.500"	42°	6.000"	12.000"	780-42351	\$29.99
3.000"	80°	2.000"	5.875"	780-80301	\$29.99
3.500"	80°	2.000"	5.750"	780-80351	\$29.99

## STEPPED BAND CLAMPS

Smooth transition taper allows proper fit to seal expanded slip-fit connections. Great for muffler/tail pipe connections.



DESCRIPTION	PART#	PRICE
BAND CLAMP FOR 2.500" JUNCTION	789-70250	\$34.99
BAND CLAMP FOR 2.750" JUNCTION	789-70275	\$34.99
BAND CLAMP FOR 3.000" JUNCTION	789-70300	\$34.99
BAND CLAMP FOR 3.500" JUNCTION	789-70350	\$34.99

Models for 2.500", 2.750" 3.000" or 3.500" pipe sizes. 1 clamp/pkg.

## EXHAUST TIPS

With their unique insert design, TQ Tips® allow for a flush fit with the outside diameter of your exhaust's tail pipe. This makes for a smooth, clean look that doesn't take away from your car's appearance like bulky, clamped-on tips tend to do. Another quality feature of these tips is the billet aluminum construction, giving them unmatched strength and function.



DESCRIPTION	PART#	PRICE
TQ TIP FOR 2.500" OUTLET (SINGLE TIP)	794-93025	\$34.99
TQ TIP FOR 3.000" OUTLET (SINGLE TIP)	794-93030	\$34.99
TQ TIP FOR 2.500" OUTLET (2 PACK)	794-93026	\$69.99
TQ TIP FOR 3.000" OUTLET (2 PACK)	794-93031	\$69.99

## TURNDOWNS

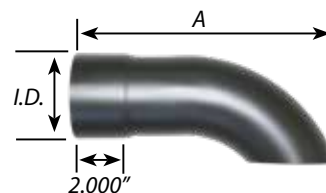

INNER DIAMETER	A	PART#	PRICE
3.000"	10.000"	780-00100	\$39.99
3.500"	10.000"	780-00200	\$34.99
4.000"	11.000"	780-00050	\$39.99

## ADAPTER PLATE KIT



DESCRIPTION	OPENING SIZE	PART#	PRICE
SBC STD. 23° TO STAHL PATTERN (0.625" THICK)	1.125" X 1.125"	796-00100	\$176.99

Includes plates and hardware for both heads.

Designed to be machined to size, to port match Head port.

## VISIT US ONLINE

- SHOP THE ONLINE STORE
- WATCH TUTORIALS
- REVIEW PRODUCT TECH



[www.DynatechHeaders.com](http://www.DynatechHeaders.com)

## FEATURES & BENEFITS

# WHAT IS IN A QUALITY SYSTEM?



**0.375" THICK  
CNC LASER-CUT  
FLANGES**



**4-BOLT BALL &  
SOCKET COLLECTOR  
FLANGES**



**FIBER  
GASKETS**



**3.000" WIDE / 2-BOLT  
BAND CLAMPS**

**PERFECT, DIRECT BOLT-ON FIT**

**100%** JIG ASSEMBLED AND CHECKED  
FOR AN EXCELLENT FIT

**OPTIMIZED TUBE LENGTH**  
FOR INCREASED H.P. AND TORQUE

**CERAMIC COATED FINISH**

**ALL FLANGES**



MACHINE SURFACED  
AFTER WELDING

**MADE IN THE U.S.A.**



DETAILED  
INSTRUCTIONS  
& HARDWARE  
INCLUDED

**ONE YEAR  
LIMITED  
WARRANTY**

AFCO Performance Group, LLC will repair or replace any products found upon our inspection to be defective in workmanship or material within 12 months from date of purchase for the original purchaser. Except for the limited warranty set forth herein, AFCO Performance Group, LLC makes no warranties either expressed or implied, written or oral, with regard to the products including, without limitation, any warranty of merchantability or fitness for a particular purpose. In no event shall AFCO Performance Group, LLC be liable for any special, incidental or consequential damages, or any other damages whatsoever arising out of or connected with the use or misuse of the products. Purchasers acknowledge and agree that no person, entity or agent of AFCO Performance Group, LLC has any authority to make any statement contrary to this disclaimer and that any warranty statements or representations allegedly made on behalf of AFCO Performance Group, LLC by any such person, entity or agent are void. AFCO Performance Group, LLC products are not D.O.T. approved or intended for street use. Purchasers are relying solely on their own skill and judgment to select, purchase and use suitable products and assume all responsibility and risk with regard thereto.



# MUSCLE CAR



*.375" thick, laser-cut, surfaced flanges for an excellent seal.*

*Unique port design accommodates Std. 23 Degree Chevy, "D" Port, and many other Std. Chevy Bolt pattern heads (aluminum and cast iron).*

*Long tube headers for maximum torque and horsepower across the power range.*

*Clears 600 Series and all factory steering boxes, power and manual styles.*

***Ceramic Coating INSIDE AND OUT with a three year warranty on the coating.***

- *Designed with excellent ground clearance in mind, when using standard Small Block Chevy Engine Mounts and Factory Front Subframe.*
- *Using Big Block Engine Mounts / Stands and Aftermarket Subframes typically set the engine lower which will result in ground clearance issues.*
- *LSX Conversion Models must use specified mounts described in the installation manual.*
- *Available in multiple sizes, depending on application.*



***Unique "Ball & Socket" designed reducer cones, included with every set.***



# MUSCLE CAR

**MUSCLEMAXX®**

## '67 - '69 CAMARO

STAINLESS STEEL, CERAMIC COATED & PAINTED HEADERS

► FITS: **LSX** / SBC / BBC

**1 YEAR LIMITED WARRANTY**

**MADE IN THE U.S.A.**

- 0.375" thick, laser-cut flanges to provide the ultimate leak-free seal.
- SBC flanges specifically designed to fit: 23 deg. standard port, D-port, Fast Burn, LT1 and crate engines.
- CNC laser-cut flanges feature raised port location for increased power.
- BBC headers come painted standard **ceramic coating is optional.**
- LSX & SBC headers comes in high-temp, silver ceramic coating inside and out.
- Race-proven stepped tube design for maximum street/strip performance.
- New design clears the following steering boxes: 600, 700, 800 & factory manual/power with 23° aluminum/factory heads/straight or angle plugs.
- Includes bolts and gaskets.
- Direct bolt-on fit.
- 794-03006 Bracket Set is needed for all MuscleMAXX® Camaro & Chevelle headers for factory air compressor mounting.

**NEW!**



# MUSCLE CAR

Reducer cone kit  
included w/ all headers.



BLACK  
PAINTED



HEADER TUBE SIZE	2.500" REDUCER	3.000" REDUCER	PRICE
1.625" - 1.750" (SBC) STAINLESS <b>NEW!</b>	740-11510	740-21510	\$999.99
1.750" - 1.875" (SBC) STAINLESS <b>NEW!</b>	740-11610	740-21610	\$999.99
2.125" - 3.500" (BBC STD) PAINTED	-	740-59310	\$599.99
2.125" - 3.500" (BBC TALL) PAINTED	-	750-91910	\$699.99
1.875" STAINLESS (LS SERIES)	715-31425***	715-31430***	\$999.99

\*\*\* Designed around: Muscle Rods Engine Mount Kit #106-1302-00, Detroit Speed Engine Mount Kit #DSE-060401, Muscle Rods Sure Fit Crossmember Kit #106-2200-00, 4LS0E transmission, factory AC, power brakes, and factory subframe. Steering boxes 600 series/factory manual/power will clear factory LS style plug wires. Designed for maximum ground clearance. If using with Exhaust System 793-91125 some modification will be required (modification of the 793-91125).

\* Aftermarket plug wires required for fuel injected applications.  
\*\* Engine Mounts: Detroit Speed Motor Mount Kit # DSE-060401. Transmission Cross Member: BPT-1002 (Fit up with a 4L60 Transmission).  
\*\*\*\* On convertible Camaro models, the 3.000" system cannot be used. The 2.500" system and use of Hotchkis Performance X-Brace is required. Hotchkis Part# 1404. Subframe: OEM Factory Original GM - Using these headers with any combination other than what is specified may cause fitment issues.

# MUSCLE CAR

**MUSCLEMAXX®**

## '68-'74 NOVA

STAINLESS STEEL, CERAMIC COATED & PAINTED HEADERS

► FITS: **LSX** / SBC / BBC

**1 YEAR LIMITED WARRANTY**

**MADE IN THE U.S.A.**

- 0.375" thick, laser-cut flanges to provide the ultimate leak-free seal.
- Flanges fit most 23° SBC standard port heads including: D-Port, Fast Burn, LT1, LS and crate engines.
- CNC laser-cut flanges feature raised port location for increased power.
- BBC headers comes painted standard - ceramic coating is optional.
- LSX & SBC headers comes in high-temp, silver ceramic coating inside and out.
- Race-proven stepped tube design for maximum street/strip performance.
- New design clears the following steering boxes: 600 & factory manual/power with 23° aluminum / factory heads / straight or angle plugs.
- Includes bolts and gaskets.
- Direct bolt-on fit.

**NEW!**





# MUSCLE CAR

Reducer cone kit included w/ all headers.



BLACK PAINTED



HEADER TUBE SIZE	2.500" REDUCER	3.000" REDUCER	PRICE
1.625" - 1.750" (SBC) STAINLESS <b>NEW!</b>	740-11510	740-21510	\$999.99
1.750" - 1.875" (SBC) STAINLESS <b>NEW!</b>	740-11610	740-21610	\$999.99
2.125" - 3.500" (BBC STD) PAINTED	-	740-59310	\$599.99
2.125" - 3.500" (BBC TALL) PAINTED	-	750-91910	\$699.99
1.875" STAINLESS (LS SERIES)	715-31425***	715-31430***	\$999.99

\*\*\* Designed around: Muscle Rods Engine Mount Kit #106-1302-00, Detroit Speed Engine Mount Kit #DSE-060401, Muscle Rods Sure Fit Crossmember Kit #106-2200-00, 4LS0E transmission, factory AC, power brakes, and factory subframe. Steering boxes 600 series/factory manual/power will clear factory LS style plug wires. Designed for maximum ground clearance. If using with Exhaust System 793-91125 some modification will be required (modification of the 793-91125).

\* Aftermarket plug wires required for fuel injected applications.  
 \*\* Engine Mounts: Detroit Speed Motor Mount Kit # DSE-060401.  
 Transmission Cross Member: BPT-1002 (Fit up with a 4L60 Transmission).  
 \*\*\*\* On convertible Camaro models, the 3.000" system cannot be used.  
 The 2.500" system and use of Hotchkis Performance X-Brace is required. Hotchkis Part# 1404.  
 Subframe: OEM Factory Original GM - Using these headers with any combination other than what is specified may cause fitment issues.

# MUSCLE CAR

**MUSCLEMAXX®**

## '70-'81 CAMARO

CERAMIC COATED HEADERS

► FITS: **LSX** / SBC

**1 YEAR LIMITED WARRANTY**

**MADE IN THE U.S.A.**

- 0.375" thick, laser-cut flanges to provide the ultimate leak-free seal.
- SBC flanges specifically designed to fit: 23 deg. standard port, D-port, Fast Burn, LT1 and crate engines.
- Comes in high-temp. silver ceramic coating inside and out.
- CNC laser-cut flanges feature raised port location for increased power.
- Race-proven stepped tube design for maximum street/strip performance.
- Includes bolts and gaskets.
- Direct bolt-on fit.
- 794-03006 Bracket Set is needed for all MuscleMAXX® Camaro & Chevelle headers for factory air compressor mounting.



CERAMIC COATED



Reducer cone kit included w/ all headers.



Headers not included with exhaust kit.



### HEADER TUBE SIZE

1.750" - 1.875" X 3.000" (SBC)

\*1.875" X 3.000" (LS SERIES)

### 2.500" REDUCER

740-19310

715-19410

### 3.000" REDUCER

740-29310

715-29410

### PRICE

\$699.99

\$699.99

Transmission Cross member: Stock OEM Subframe: OEM Factory Original GM

\* Aftermarket plug wires required for fuel injected applications.

\* Engine Mounts: Speedway Motors part# 910-18012 (DO NOT use Big Block Chevy engine mount brackets. They are approximately .250" narrower and will lower the engine, causing ground clearance issues.)

Use 916-7081 Kit, or 910-18012 Mount & 910-18016 LS Adapt Plates.

## STAINLESS STEEL **PRO CRUISER**

### BLOCK HUGGER HEADERS

► **FITS: SBC 23°**

#### 1 YEAR LIMITED WARRANTY

For applications where space is a primary concern, sometimes a short header is the only solution. For these cases, we offer our all-stainless Pro Cruiser Series block hugger header. They feature the same exceptional levels of quality, fit, and finish in a compact package.

- SBC Standard 23° 6-bolt pattern.
- 0.375" flange.
- 1.625" primaries.
- 2.500" collector.
- 2.000" reducer cones.
- 100% stainless steel construction.
- Includes bolts & gaskets.



#### DESCRIPTION

BLOCK HUGGER HOT ROD HEADERS (Fits Straight Head Plugs Only)

PART#

PRICE

730-10010

\$399.99



Machined flange is flat ground for proper fit and leak-free performance.

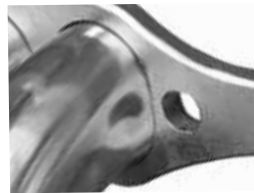

Machined flange features unique bevel that adds a quality look.

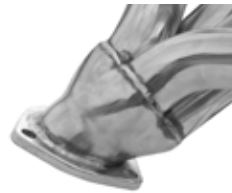

High-flow contoured collector for increased power.



Finished welds offer smooth exhaust flow and excellent seal.





# HIGH PERFORMANCE

- Perfect, direct bolt-on fit.
- 0.375" Thick CNC laser-cut flanges.
- 4-Bolt ball & socket collector flanges.
- All flanges machine surfaced after welding.
- 3.000" Wide, 2-bolt band clamps.
- Optimized tube length for Hp and torque.
- 100% jig assembled and checked for an excellent fit.
- Triple layer stainless steel gaskets.
- T304 stainless steel construction.
- Detailed instructions & all hardware included.

## HOW TO PURCHASE YOUR DYNATECH® EXHAUST SYSTEM

### 1 HEADERS

The headers consist of a long tube set of headers with all of the required hardware included for the installation. The headers alone cannot be installed as a "Bolt In" to your factory catalytic converters and system.



### 2 INTERMEDIATE SECTION

The intermediate section consists of the required components to connect the headers to your factory or aftermarket "Cat-Back" exhaust system. In most cases, you have two choices when it comes to selecting your intermediate section. You can choose either the "Catted" or "Non Catted" version.

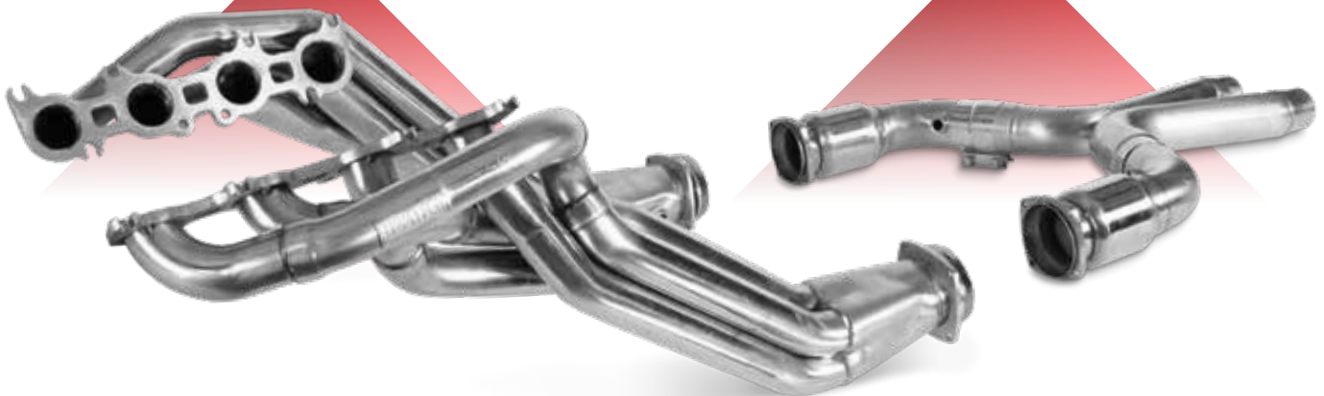

These products are intended for racing and off-road applications. Not legal for sale or use in the state of California, nor in states which have adopted California emission standards.



# HIGH PERFORMANCE QUICK GUIDE

## FORD



APPLICATION	YEAR	ENGINE	HEADERS	CATTED	NON-CATTED	HP GAIN	INST. TIME	PAGE
MUSTANG GT	'18 - '19	5.0L	722-44310	722-75320	722-75330	32	5-7 hrs	29
MUSTANG SHELBY GT350	'15 - '17	5.0L	722-65310	722-65320	722-65330	26	5-6 hrs	30
MUSTANG GT 5.0	'11 - '14	5.0L	722-74310	722-74320	722-74330	32	5-7 hrs	31
MUSTANG GT 5.0	'15 - '17	5.0L	722-74310	722-75320	722-75330	32	5-7 hrs	31
MUSTANG SHELBY GT500	'07 - '10	ALL	722-64310	722-54320	722-54330	15	6-8 hrs	32
MUSTANG SHELBY GT500	'11 - '14	ALL	722-84310	722-74420	722-74330	15	6-8 hrs	32
MUSTANG GT	'05 - '10	4.6L	722-54310	722-54320	722-54330	30	5-7 hrs	33

## DODGE



APPLICATION	YEAR	ENGINE	HEADERS	CATTED	NON-CATTED	HP GAIN	INST. TIME	PAGE
CHALLENGER, MAGNUM, CHARGER, 300C	'05 - '17	5.7L HEMI	724-73310	724-73320	724-73330	30	5-7 hrs	34
CHALLENGER, MAGNUM, CHARGER, 300C	'05 - '17	SRT-8 6.1L & 6.4L HEMI	728-73310	728-73320	728-73330	30	5-7 hrs	34

## GM



APPLICATION	YEAR	ENGINE	HEADERS	CATTED	NON-CATTED	HP GAIN	INST. TIME	PAGE
CORVETTE C7	'14 - '18	V8	715-63810	715-63820	715-63830	25	6-8 hrs	35
CORVETTE C7 Z06	'14 - '18	V8	715-63810	715-63920	715-63830	25	6-8 hrs	35
CORVETTE C6	'05 - '08	V8	715-63510	715-63520	715-63530	25	4-6 hrs	36
CORVETTE C6	'09 - '13	V8	715-63510	715-63540	715-63550	25	4-6 hrs	36
CORVETTE C6 Z06	'05 - '13	V8	715-63510	715-63620	715-63630	25	4-6 hrs	36
CORVETTE C5	'97 - '00	V8	715-73610	715-73720	715-73730	30	4-6 hrs	37
CORVETTE C5	'01 - '03	V8	715-73710	715-73720	715-73730	30	4-6 hrs	37
CORVETTE C5	'04	V8	715-74710	715-74720	715-74730	30	4-6 hrs	37
CADILLAC CTS-V 1.875"	'09 - '15	6.2L	715-75010	715-75020	715-75030	64	4-6 hrs	38
CADILLAC CTS-V 2.000"	'09 - '15	6.2L	715-75210	715-75040	715-75050	64	4-6 hrs	38
CAMARO SS/ZL1 1.875"	'16 - '17	6.2L	715-75510	715-75520	715-75530	28	4-6 hrs	39
CAMARO SS/ZL1 2.000"	'16 - '17	6.2L	715-76010	715-75520	715-75530	28	4-6 hrs	39
CAMARO (5TH GEN.) 1.875"	'10 - '15	6.2L	715-74010	715-73920	715-73930	36	4-6 hrs	40
CAMARO (5TH GEN.) 2.000"	'10 - '15	6.2L	715-74110	715-74020	715-74030	36	4-6 hrs	40
CAMARO, FIREBIRD, F-BODY	'98 - '99	V8	715-73210	715-73220	715-73230	19	4-6 hrs	41
CAMARO, FIREBIRD, F-BODY	'00 - '02	V8	715-73310	715-73220	715-73230	19	4-6 hrs	41

These products are intended for racing and off-road applications. Not legal for sale or use in the state of California, nor in states which have adopted California emission standards.

## FEATURES & BENEFITS

# WHAT IS IN A QUALITY SYSTEM?



**0.375" THICK  
CNC LASER-CUT  
FLANGES**



**DONUT  
GASKET**



**TRIPLE LAYER  
STAINLESS  
STEEL GASKETS**



**3.000" WIDE / 2-BOLT  
BAND CLAMPS**

## PERFECT, DIRECT BOLT-ON FIT

**100%** JIG ASSEMBLED AND CHECKED  
FOR AN EXCELLENT FIT

**OPTIMIZED TUBE LENGTH**  
FOR INCREASED H.P. AND TORQUE

**100% T304** STAINLESS STEEL  
CONSTRUCTION

## LIMITED LIFETIME WARRANTY

of purchase is required for any / all warranty claims. Except for the limited lifetime warranty set forth herein, AFCO Performance Group, LLC makes no warranties either expressed or implied, written or oral, with regard to the products including, without limitation, any warranty of merchantability or fitness for a particular purpose. In no event shall AFCO Performance Group, LLC be liable for any special, incidental or consequential damages, or any other damages whatsoever arising out of or connected with the use or misuse of the products. Purchasers acknowledge and agree that no person, entity or agent of AFCO Performance Group, LLC has any authority to make any statement contrary to this disclaimer and that any warranty statements or representations allegedly made on behalf of AFCO Performance Group, LLC by any such person, entity or agent are void. AFCO Performance Group, LLC products are not D.O.T. approved and are intended for off-road use only. Purchasers are relying solely on their own skill and judgment to select, purchase and use suitable products and assume all responsibility and risk with regard thereto.

Catalytic Converters: Catalytic converters included with any SuperMAXX® system are limited to a 2 year limited replacement warranty. For any catalytic converter warranties, it is required that the product be returned to AFCO Performance Group, LLC for review. After inspection, a determination will be made as to what caused the failure. Any failure determined to be caused by an incorrect engine tune, or any other use for which the converter was not designed, will void the warranty. Any freight cost to get the product to AFCO Performance Group, LLC for evaluation will be the customer's responsibility.

## ALL FLANGES



MACHINE SURFACED  
AFTER WELDING

**MADE IN THE U.S.A.**



DETAILED  
INSTRUCTIONS  
& HARDWARE  
INCLUDED

These products are intended for racing and off-road applications. Not legal for sale or use in the state of California, nor in states which have adopted California emission standards.

**NEW!**

**SUPERMAXX®**

# 2018-19 MUSTANG GT

**STAINLESS STEEL HEADERS**

**LIMITED LIFETIME WARRANTY**

**MADE IN THE U.S.A.**



5.000"  
INTERMEDIATE  
TUBES W/ CATS



5.000"  
INTERMEDIATE  
TUBES W/O CATS



## FEATURES

**PRIMARY TUBE SIZE:** 1.875"

**COLLECTOR SIZE:** 3.000"

**SYSTEM TUBE SIZE:** 3.000"

**MATERIAL:** T304 Stainless

**TRANS:** Manual & Automatic

**INCLUDED:** Detailed instructions and all needed hardware.

**FIT:** Some cutting required for any factory or O.E. size aftermarket cat back.

**INSTALL TIME:** 5-7 hours

**+32 HORSEPOWER**  
**+20 FT-LBS TORQUE**

*Ceramic Coating Services  
are Available.*

*Call Dynatech® for Details.*

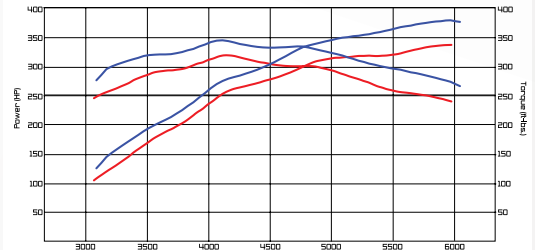

**Dyno Chart**

■ Stock ■ SuperMAXX®

**\$949.99**

**HEADERS  
ONLY**

722-44310

**\$749.99**

**INTERMEDIATE  
TUBES W/ CATS**

722-75320

**\$699.99**

**INTERMEDIATE  
TUBES W/O CATS**

722-75330

**APPLICATION**

**2018-19 MUSTANG GT**



These products are intended for racing and off-road applications. Not legal for sale or use in the state of California, nor in states which have adopted California emission standards.

CONNECT WITH DYNATECH® [www.DynatechHeaders.com](http://www.DynatechHeaders.com) 800-848-5850





**SUPERMAXX**

# '15 - '17 MUSTANG SHELBY GT350

## STAINLESS STEEL HEADERS

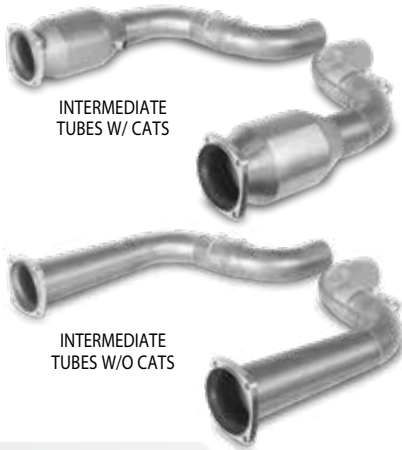

INTERMEDIATE TUBES W/ CATS

INTERMEDIATE TUBES W/O CATS



### FEATURES

- PRIMARY TUBE SIZE:** 1.750" - 1.875" Stepped
- COLLECTOR SIZE:** 3.000"
- SYSTEM TUBE SIZE:** 3.000"
- MATERIAL:** T304 Stainless
- TRANS:** Manual & Automatic
- INCLUDED:** Detailed instructions and all needed hardware.
- FIT:** Direct Bolt-Up to any factory or O.E. size aftermarket cat back.
- INSTALL TIME:** 5-6 hours

**+26 HORSEPOWER**  
**+13 FT-LBS TORQUE**  
*\*with a tune.*

*Ceramic Coating Services are Available.*  
 Call Dynatech® for Details.

**LIMITED LIFETIME WARRANTY**  
**MADE IN THE U.S.A.**

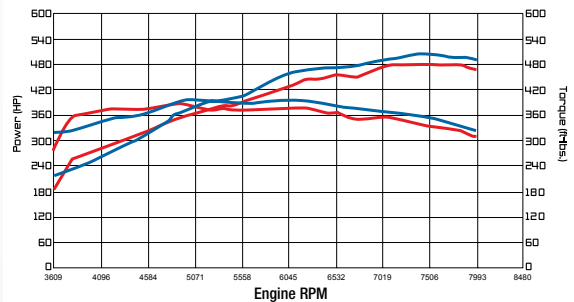

**Dyno Chart** ■ Stock ■ SuperMAXX®

**\$999.99**

**HEADERS ONLY**

722-65310



**\$799.99**

**INTERMEDIATE TUBES W/ CATS**

722-65320



**\$599.99**

**INTERMEDIATE TUBES W/O CATS**

722-65330

**APPLICATION**

'15 - '17 MUSTANG GT350

These products are intended for racing and off-road applications. Not legal for sale or use in the state of California, nor in states which have adopted California emission standards.





**SUPERMAXX®**

# '11-'17 MUSTANG 5.0

## STAINLESS STEEL HEADERS

**LIMITED LIFETIME WARRANTY**  
**MADE IN THE U.S.A.**



5.000"  
INTERMEDIATE  
TUBES W/ CATS



5.000"  
INTERMEDIATE  
TUBES W/O CATS



### FEATURES

- PRIMARY TUBE SIZE:** 1.750" - 1.875"
- COLLECTOR SIZE:** 3.000"
- SYSTEM TUBE SIZE:** 3.000"
- MATERIAL:** T304 Stainless
- TRANS:** Manual & Automatic
- INCLUDED:** Detailed instructions and all needed hardware.
- FIT:** Some cutting required for any factory or O.E. size aftermarket cat back.
- INSTALL TIME:** 5-7 hours

**+32 HORSEPOWER**  
**+20 FT-LBS TORQUE**

*Ceramic Coating Services  
are Available.*  
Call Dynatech® for Details.

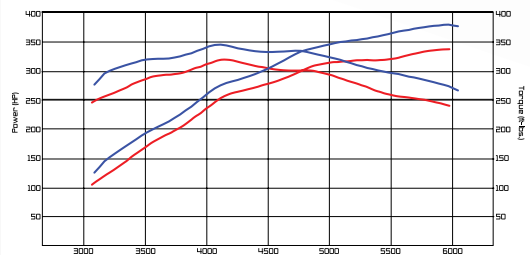

**Dyno Chart** ■ Stock ■ SuperMAXX®

APPLICATION	HEADERS ONLY	+	INTERMEDIATE TUBES W/ CATS	OR	INTERMEDIATE TUBES W/O CATS	OR	SUPERCHARGED SUPERCATTED 3.000"
'15 - '17 MUSTANG 5.0/CONVERTIBLE	\$999.99		\$799.99		STARTING AT \$649.99		\$999.99
'11 - '14 MUSTANG 5.0	722-74310		722-75320		722-75330		722-75420
	722-74310		722-74320		722-74330		722-74420

These products are intended for racing and off-road applications. Not legal for sale or use in the state of California, nor in states which have adopted California emission standards.





**SUPERMAXX®**

# '07 - '14 MUSTANG SHELBY GT500 STAINLESS STEEL HEADERS

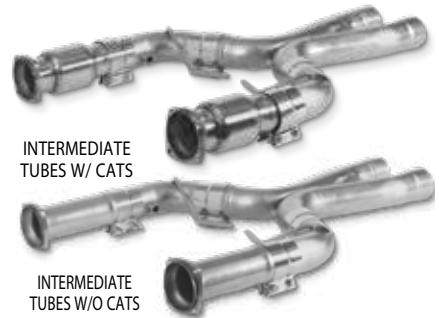

INTERMEDIATE  
TUBES W/ CATS

INTERMEDIATE  
TUBES W/O CATS

## FEATURES

- PRIMARY TUBE SIZE:** 1.875"
- COLLECTOR SIZE:** 3.000"
- SYSTEM TUBE SIZE:** 2.500" or 3.000"
- MATERIAL:** T304 Stainless
- TRANS:** Manual & Automatic
- INCLUDED:** Detailed instructions and all needed hardware.
- FIT:** Direct Bolt-Up to any factory or O.E. size aftermarket cat back.
- INSTALL TIME:** 6-8 hours

**LIMITED LIFETIME WARRANTY**  
**MADE IN THE U.S.A.**

### Dyno Chart

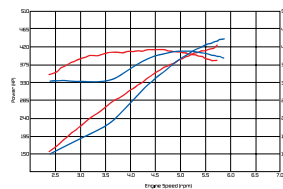

**'07-'12**  
▶ **+15 HORSEPOWER**  
▶ **+24 FT-LBS TORQUE**

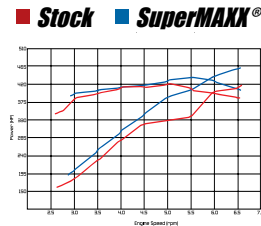

**2013**  
▶ **+49 HORSEPOWER**  
▶ **+32 FT-LBS TORQUE**

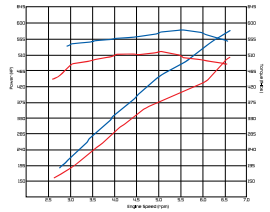

**2014**  
▶ **+70 HORSEPOWER**  
▶ **+59 FT-LBS TORQUE**

*Ceramic Coating Services are Available.*

*Call Dynatech® for Details.*

DESCRIPTION	'07 - '10 SHELBY GT500	'11 - '14 SHELBY GT500	PRICE
HEADERS ONLY	722-64310	722-84310	\$999.99
<b>+</b> 2.500" INTERMEDIATE TUBES W/ CATS	722-54320	-	\$649.99
2.500" INTERMEDIATE TUBES W/O CATS	722-54330	-	\$499.99
3.000" INTERMEDIATE TUBES W/ CATS (SUPER CATTED)	-	722-74420	\$999.99
3.000" INTERMEDIATE TUBES W/O CATS	-	722-74330	\$649.99

These products are intended for racing and off-road applications. Not legal for sale or use in the state of California, nor in states which have adopted California emission standards.



**SUPERMAXX®**  
**'05 - '10 MUSTANG GT**  
**STAINLESS STEEL HEADERS**

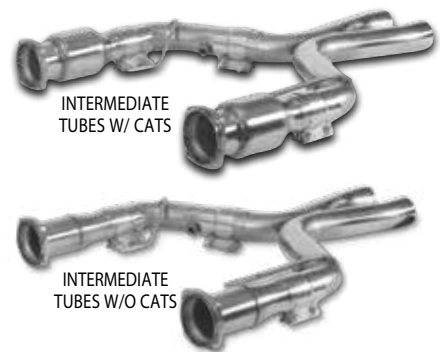

INTERMEDIATE  
TUBES W/ CATS

INTERMEDIATE  
TUBES W/O CATS

**FEATURES**

- PRIMARY TUBE SIZE:** 1.750"
- COLLECTOR SIZE:** 3.000"
- SYSTEM TUBE SIZE:** 2.500"
- MATERIAL:** T304 Stainless
- TRANS:** Manual & Automatic
- INCLUDED:** Detailed instructions and all needed hardware.
- FIT:** Direct Bolt-Up to any factory or O.E. size aftermarket cat back.
- INSTALL TIME:** 5-7 hours

**+30 HORSEPOWER**  
**+30 FT-LBS TORQUE**

*Ceramic Coating Services  
 are Available.  
 Call Dynatech® for Details.*

**LIMITED LIFETIME WARRANTY**  
**MADE IN THE U.S.A.**

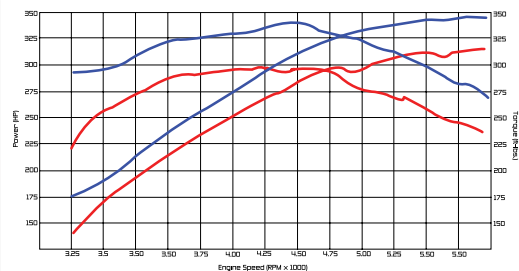

**Dyno Chart**

■ Stock ■ SuperMAXX®

**\$899.99**

**HEADERS  
 ONLY**

722-54310



**\$649.99**

**INTERMEDIATE  
 TUBES W/ CATS**

722-54320



**\$499.99**

**INTERMEDIATE  
 TUBES W/O CATS**

722-54330

**APPLICATION**

'05 - '10 MUSTANG GT

These products are intended for racing and off-road applications. Not legal for sale or use in the state of California, nor in states which have adopted California emission standards.





**SUPERMAXX®**

**'05 - '17 CHALLENGER / CHARGER / 300C / MAGNUM**

**LIMITED LIFETIME WARRANTY  
MADE IN THE U.S.A.**

**STAINLESS STEEL HEADERS**

**MATERIAL:** T304 Stainless  
**TRANS:** Manual & Automatic  
**INCLUDED:** Detailed instructions and all needed hardware.  
**FIT:** Direct Bolt-Up to any factory or O.E. size aftermarket cat back.  
**INSTALL TIME:** 5-7 hours

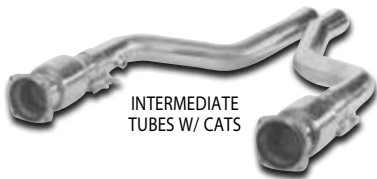

INTERMEDIATE TUBES W/ CATS

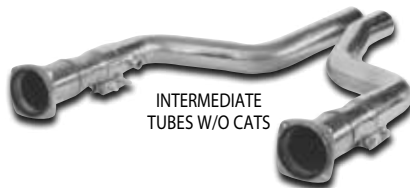

INTERMEDIATE TUBES W/O CATS

**5.7 Hemi**

**PRIMARY TUBE SIZE:** 1.750"  
**COLLECTOR SIZE:** 3.000"  
**SYSTEM TUBE SIZE:** 2.500"

**+30 HORSEPOWER  
+30 FT-LBS TORQUE**

**SRT-8 (6.1 & 6.4 Hemi)**

**PRIMARY TUBE SIZE:** 1.875"  
**COLLECTOR SIZE:** 3.000"  
**SYSTEM TUBE SIZE:** 2.750" & 3.000"

**+30 HORSEPOWER  
+24 FT-LBS TORQUE**

*Ceramic Coating Services are Available.*

*Call Dynatech® for Details.*



**SRT-8**  
Port Matched Flange

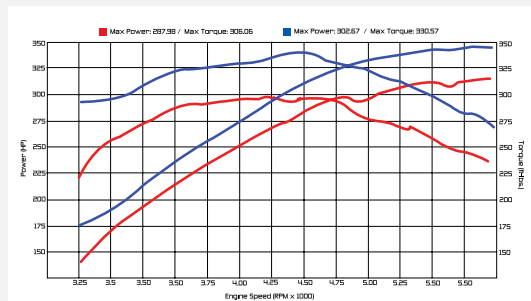

**Dyno Chart** ■ Stock ■ SuperMAXX®

DESCRIPTION	5.7 HEMI	PRICE
HEADERS ONLY	724-73310	\$999.99
INTERMEDIATE TUBES W/ CATS	724-73320	\$699.99
INTERMEDIATE TUBES W/O CATS	724-73330	\$599.99

DESCRIPTION	SRT-8	PRICE
HEADERS ONLY	728-73310	\$999.99
INTERMEDIATE TUBES W/ CATS	728-73320	\$899.99
INTERMEDIATE TUBES W/O CATS	728-73330	\$699.99
3.000" INTERMEDIATE TUBES W/ CATS	728-73340	\$899.99
3.000" INTERMEDIATE TUBES W/O CATS	728-73350	\$699.99

*These products are intended for racing and off-road applications. Not legal for sale or use in the state of California, nor in states which have adopted California emission standards.*





**SUPERMAXX®**

# '14 - '18 CORVETTE C7/Z06

## STAINLESS STEEL HEADERS

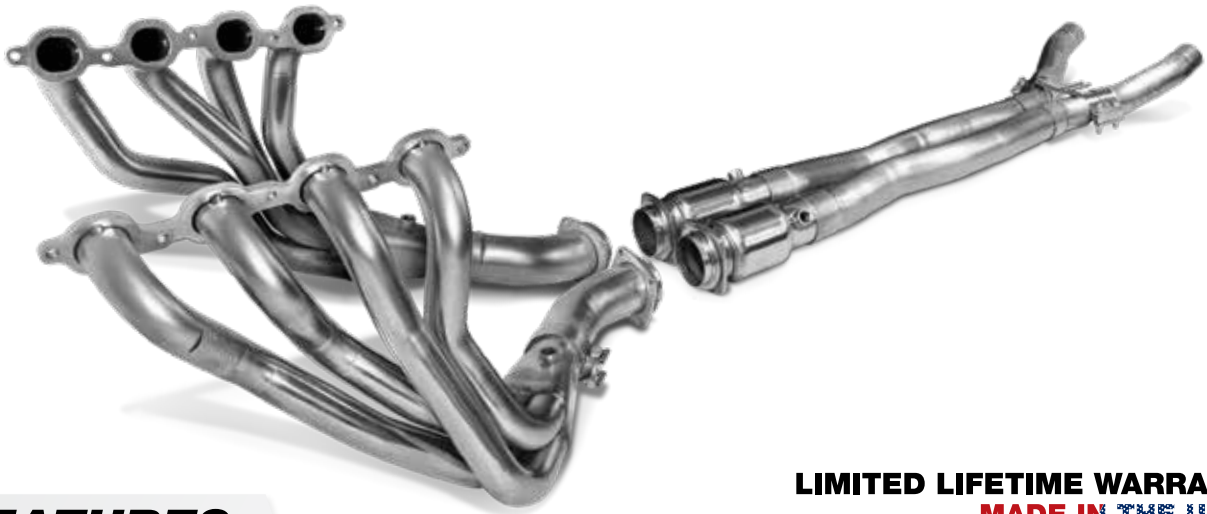

**LIMITED LIFETIME WARRANTY**  
**MADE IN THE U.S.A.**

### FEATURES

- PRIMARY TUBE SIZE:** 1.875"
- COLLECTOR SIZE:** 3.000"
- SYSTEM TUBE SIZE:** 3.000"
- MATERIAL:** T304 Stainless
- TRANS:** Manual & Automatic
- INCLUDED:** Detailed instructions, and all needed hardware.
- FIT:** Direct Bolt-Up to any factory or O.E. size aftermarket cat back.
- INSTALL TIME:** 6-8 hours

**+25 HORSEPOWER**  
**+25 FT-LBS TORQUE**

*Ceramic Coating Services  
are Available.  
Call Dynatech for Details.*

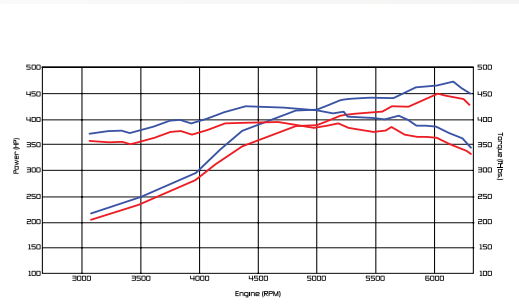

**Dyno Chart** ■ Stock ■ SuperMAXX®

APPLICATION	STARTING AT \$1099.99	+	STARTING AT \$899.99	OR	STARTING AT \$799.99
	HEADERS ONLY		INTERMEDIATE TUBES W/ CATS		INTERMEDIATE TUBES W/O CATS
'14 - '18 CORVETTE C7	715-63810		715-63820		715-63830
'14 - '18 CORVETTE Z06	715-63810		715-63920		715-63830

These products are intended for racing and off-road applications. Not legal for sale or use in the state of California, nor in states which have adopted California emission standards.



**SUPERMAXX**

# '05 - '13 CORVETTE C6/Z06

**STAINLESS STEEL HEADERS**

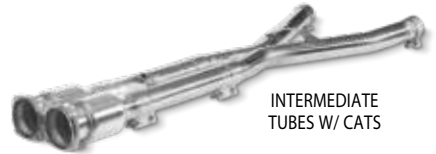

**LIMITED LIFETIME WARRANTY**  
**MADE IN THE U.S.A.**

## FEATURES

- PRIMARY TUBE SIZE:** 1.875"
- COLLECTOR SIZE:** 3.000"
- SYSTEM TUBE SIZE:** 2.500" or 3.000"
- MATERIAL:** T304 Stainless
- TRANS:** Manual & Automatic
- INCLUDED:** Detailed instructions and all needed hardware.
- FIT:** Direct Bolt-Up to any factory or O.E. size aftermarket cat back.
- INSTALL TIME:** 4-6 hours

**+25 HORSEPOWER**  
**+25 FT-LBS TORQUE**

*Ceramic Coating Services are Available.*  
*Call Dynatech® for Details.*

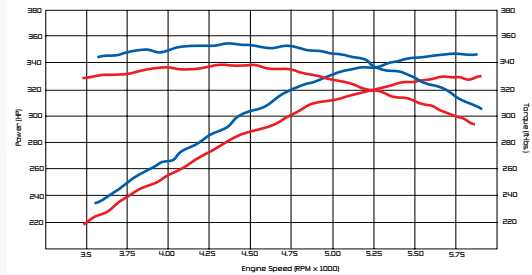

**Dyno Chart** ■ Stock ■ SuperMAXX®

APPLICATION	<b>\$999.99</b> HEADERS ONLY	+	<b>\$899.99</b> INTERMEDIATE TUBES W/ CATS	OR	<b>\$799.99</b> INTERMEDIATE TUBES W/O CATS
'05 - '08 CORVETTE C6	715-63510		715-63520		715-63530
'09 - '13 CORVETTE C6	715-63510		715-63540		715-63550
'05 - '13 CORVETTE Z06	715-63510		715-63620		715-63630

These products are intended for racing and off-road applications. Not legal for sale or use in the state of California, nor in states which have adopted California emission standards.

**SUPERMAXX®**

# '97-'04 CORVETTE C5

**STAINLESS STEEL HEADERS**



INTERMEDIATE TUBES W/ CATS

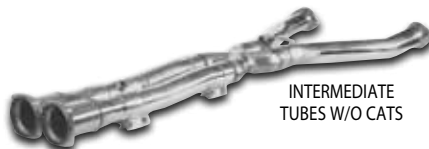

INTERMEDIATE TUBES W/O CATS



**LIMITED LIFETIME WARRANTY**  
**MADE IN THE U.S.A.**

## FEATURES

**PRIMARY TUBE SIZE:** 1.750"

**COLLECTOR SIZE:** 3.000"

**SYSTEM TUBE SIZE:** 2.500"

**MATERIAL:** T304 Stainless

**TRANS:** Manual & Automatic

**INCLUDED:** Detailed instructions and all needed hardware.

**FIT:** Direct Bolt-Up to any factory or O.E. size aftermarket cat back.

*Works with convertible models.*

**INSTALL TIME:** 4-6 hours

**+30 HORSEPOWER**  
**+30 FT-LBS TORQUE**

*Ceramic Coating Services are Available.*

*Call Dynatech® for Details.*

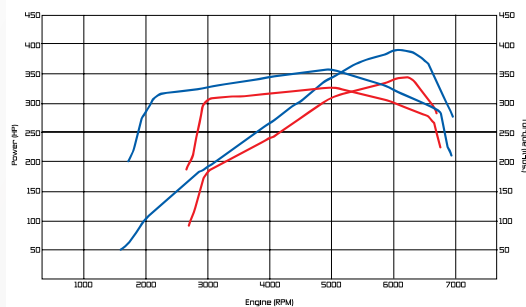

**Dyno Chart**

■ Stock ■ SuperMAXX®

**\$999.99**

**HEADERS ONLY**

**APPLICATION**

'97 - '00 CORVETTE C5

715-73610



**\$899.99**

**INTERMEDIATE TUBES W/ CATS**

'01 - '03 CORVETTE C5

715-73710



715-73720

**\$799.99**

**INTERMEDIATE TUBES W/O CATS**

'04 CORVETTE C5

715-74710

715-74720

715-73730

715-73730

715-74730

These products are intended for racing and off-road applications. Not legal for sale or use in the state of California, nor in states which have adopted California emission standards.

CONNECT WITH DYNATECH® [www.DynatechHeaders.com](http://www.DynatechHeaders.com) 800-848-5850



**SUPERMAXX**

# '09 - '15 CADILLAC CTS-V

## STAINLESS STEEL HEADERS



### FEATURES

- ENGINE:** 6.2L
- PRIMARY TUBE SIZE:** 1.875 or 2.000"
- COLLECTOR SIZE:** 3.000"
- SYSTEM TUBE SIZE:** 2.500" or 3.000"
- MATERIAL:** T304 Stainless
- TRANS:** Manual & Automatic
- INCLUDED:** Detailed instructions and all needed hardware.
- FIT:** Some cutting required for any factory or O.E. size aftermarket cat back.
- INSTALL TIME:** 4-6 hours

**+64 HORSEPOWER**  
**+58 FT-LBS TORQUE**

*Ceramic Coating Services are Available.*  
*Call Dynatech® for Details.*

**LIMITED LIFETIME WARRANTY**  
**MADE IN THE U.S.A.**

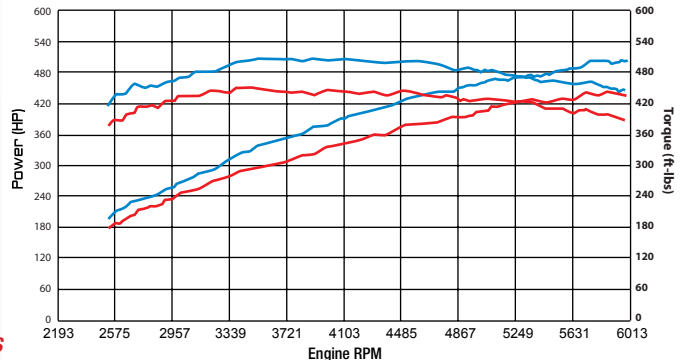

**Dyno Chart**

■ Stock ■ SuperMAXX®

**DESCRIPTION**

**PART #**

**PRICE**

HEADERS ONLY (1.875")

715-75010

\$999.99

HEADERS ONLY (2.000")

715-75210

\$1099.99



2.500" INTERMEDIATE TUBES W/ CATS

715-75020

\$899.99

2.500" INTERMEDIATE TUBES W/O CATS

715-75030

\$799.99

3.000" INTERMEDIATE TUBES W/ CATS

715-75040

\$899.99

3.000" INTERMEDIATE TUBES W/O CATS

715-75050

\$799.99

These products are intended for racing and off-road applications. Not legal for sale or use in the state of California, nor in states which have adopted California emission standards.





**SUPERMAXX®**

# '16 - '17 CAMARO SS/ZL1

## STAINLESS STEEL HEADERS

INTERMEDIATE  
TUBES KIT  
(sold separately)



**LIMITED LIFETIME WARRANTY**  
**MADE IN THE U.S.A.**

### FEATURES

- ENGINE:** 6.2L
- PRIMARY TUBE SIZE:** 1.875" or 2.000"
- COLLECTOR SIZE:** 3.000"
- SYSTEM TUBE SIZE:** 2.750"
- MATERIAL:** T304 Stainless
- TRANS:** Manual & Automatic
- INCLUDED:** Detailed instructions and all needed hardware.
- FIT:** Some cutting required for any factory or O.E. size aftermarket cat back.
- INSTALL TIME:** 4-6 Hours

**+28 HORSEPOWER**  
**+10 FT-LBS TORQUE**

*Ceramic Coating Services  
are Available.*  
Call Dynatech® for Details.

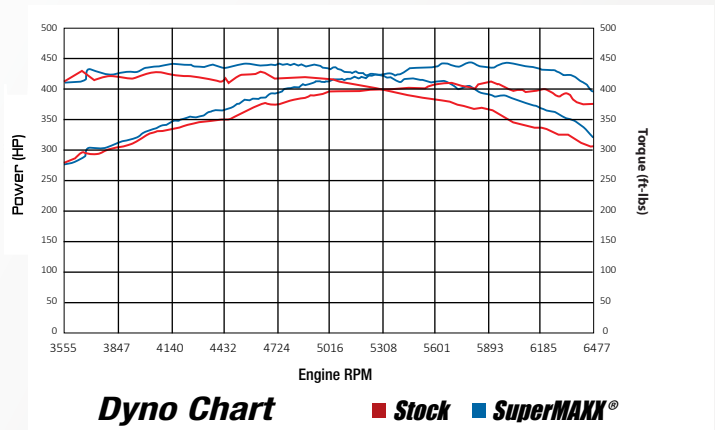

DESCRIPTION	HEADERS ONLY	PRICE	+	2.750" INTERMEDIATE TUBES W/ CATS	OR	2.750" INTERMEDIATE TUBES W/O CATS	OR	2.750" INT. TUBES W/ POWERCAT PLUS
1.875"	715-75510	\$999.99		715-75520		715-75530		715-76020
2.000"	715-76010	\$1099.99		715-75520		715-75530		715-76020

These products are intended for racing and off-road applications. Not legal for sale or use in the state of California, nor in states which have adopted California emission standards.



# '10 - '15 CAMARO (6.2L V8)

## STAINLESS STEEL HEADERS

\*Fits hard top and convertible models.

**NOW AVAILABLE  
FOR Z28**

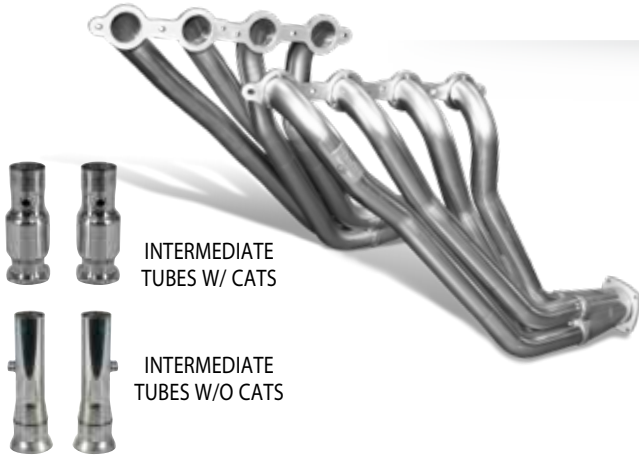

INTERMEDIATE  
TUBES W/ CATS

INTERMEDIATE  
TUBES W/O CATS



\*2010-2015 Chevy Camaro SS  
Coupe and Convertible  
Stainless Steel Exhaust System (Part #793-73925)  
Will not fit Z/28 or ZL1.  
Not compatible with factory ground effects.  
For models with factory round tail pipes.  
May not fit with rectangle rear fascia.

## FEATURES

- PRIMARY TUBE SIZE:** 1.875" or 2.000"
- COLLECTOR SIZE:** 3.000"
- SYSTEM TUBE SIZE:** 2.500", 2.750" or 3.000"
- MATERIAL:** T304 Stainless
- TRANS:** Manual & Automatic
- INCLUDED:** Detailed instructions and all needed hardware.
- FIT:** Direct Bolt-Up to any factory or O.E. size aftermarket cat back.
- INSTALL TIME:** 4-6 hours

**+36 HORSEPOWER  
+25 FT-LBS TORQUE**

*Ceramic Coating Services  
are Available.  
Call Dynatech® for Details.*

## LIMITED LIFETIME WARRANTY MADE IN THE U.S.A.

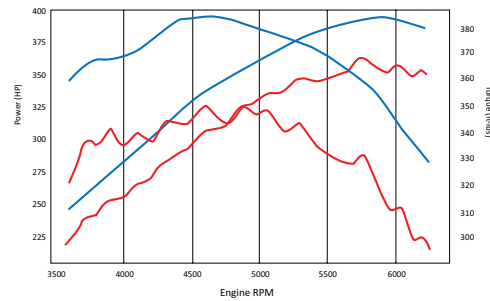

**Dyno Chart** ■ Stock ■ SuperMAXX®

DESCRIPTION	Z28 CAMARO	'10 - '15 CAMARO	ZL1 + SUPERCHARGED	PRICE
HEADERS ONLY (1.875")	715-74010	715-74010	715-74010	\$999.99
HEADERS ONLY (2.000")	715-74110	715-74110	715-74110	\$1099.99
<b>+</b> 2.500" INTERMEDIATE TUBES W/ CATS	.	715-73920	.	\$399.99
2.500" INTERMEDIATE TUBES W/O CATS	.	715-73930	.	\$229.99
2.750" INTERMEDIATE TUBES W/ CATS	715-75120	.	.	\$349.99
2.750" INTERMEDIATE TUBES W/O CATS	715-74230	.	.	\$199.99
3.000" INTERMEDIATE TUBES W/ CATS	.	715-74020	.	\$399.99
3.000" INTERMEDIATE TUBES W/O CATS	715-74330	715-74030	.	\$229.99
CAT-BACK EXHAUST SYSTEM ('10-'15)*	.	793-73925	.	\$1099.99
2.500" SUPERCATTED INTER. SECTION	.	.	715-74120	\$599.99
3.000" SUPERCATTED INTER. SECTION	.	.	715-74220	\$599.99

These products are intended for racing and off-road applications. Not legal for sale or use in the state of California, nor in states which have adopted California emission standards.

**SUPERMAXX**<sup>®</sup>

# '98 - '02 CAMARO / TRANS AM

## STAINLESS STEEL HEADERS

\* Will not fit convertible models.

**LIMITED LIFETIME WARRANTY**  
**MADE IN THE U.S.A.**



### FEATURES

**PRIMARY TUBE SIZE:** 1.750"  
**COLLECTOR SIZE:** 3.000"  
**SYSTEM TUBE SIZE:** 2.500"  
**MATERIAL:** T304 Stainless  
**TRANS:** Manual & Automatic  
**INCLUDED:** Detailed instructions and all needed hardware.  
**FIT:** Direct Bolt-Up to any factory or O.E. size aftermarket cat back.  
**INSTALL TIME:** 4-6 hours

**+19 HORSEPOWER**  
**+15 FT-LBS TORQUE**

*Ceramic Coating Services are Available.*  
*Call Dynatech<sup>®</sup> for Details.*

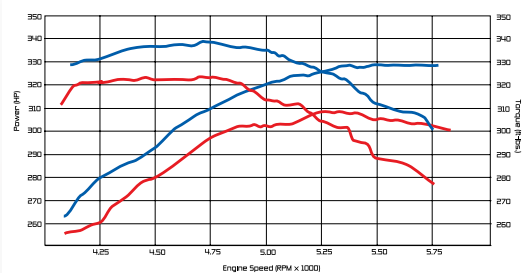

**Dyno Chart**

■ Stock ■ SuperMAXX<sup>®</sup>

**\$899.99**

**HEADERS ONLY**

**APPLICATION**

'98 - '99 4TH GENERATION F-BODY

715-73210



**\$599.99**

**INTERMEDIATE TUBES W/ CATS**

715-73220



**\$499.99**

**INTERMEDIATE TUBES W/O CATS**

715-73230

'00 - '02 4TH GENERATION F-BODY

715-73310

715-73220

715-73230

These products are intended for racing and off-road applications. Not legal for sale or use in the state of California, nor in states which have adopted California emission standards.

CONNECT WITH DYNATECH<sup>®</sup> [www.DynatechHeaders.com](http://www.DynatechHeaders.com) 800-848-5850



# ACCESSORIES

## POWERCAT CATALYTIC CONVERTERS

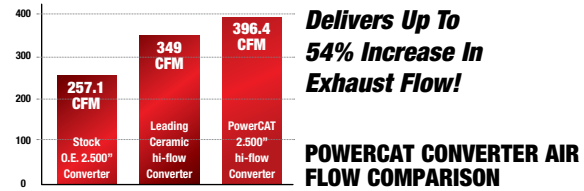

### POWERCAT CATALYTIC CONVERTERS

- Premium metallic substrate.
- Superior strength and durability.
- Stainless steel housing.
- Quicker lightoff due to higher thermal conductivity.
- Low pressure drop.
- Higher flow rates compared to stock and most after-market converters.

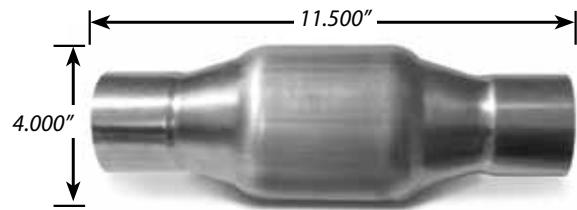

NOTE: These products are intended for racing and off-road applications. Not legal for sale or use in the state of California, nor in states which have adopted California emission standards.

DESCRIPTION	PART#	PRICE
POWERCAT 2.500" INLET AND OUTLET	779-40025	\$199.99
POWERCAT 3.000" INLET AND OUTLET	779-40030	\$199.99

### POWERCAT PLUS CATALYTIC CONVERTERS

- **Designed for supercharged & higher horsepower applications.**
- Premium metallic substrate.
- Superior strength and durability.
- Stainless steel housing.
- Quicker lightoff due to higher thermal conductivity.
- Low pressure drop.
- Higher flow rates compared to stock and most after-market converters.

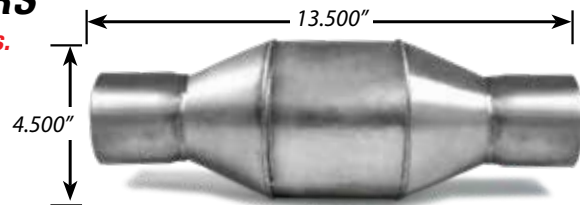

NOTE: These products are intended for racing and off-road applications. Not legal for sale or use in the state of California, nor in states which have adopted California emission standards.

DESCRIPTION	PART#	PRICE
UNIVERSAL POWERCAT PLUS 2.500" INLET / OUTLET	779-50025	\$299.99
UNIVERSAL POWERCAT PLUS 3.000" INLET / OUTLET	779-50030	\$299.99

These products are intended for racing and off-road applications. Not legal for sale or use in the state of California, nor in states which have adopted California emission standards.



# ACCESSORIES

## BALL & SOCKET KIT



Unlike common metal to metal connections, Dynatech®'s unique "4-Bolt, Ball and Socket" connection uses a 0.500" thick, tapered donut gasket, which allows for expansion and contraction while maintaining a long lasting leak free seal. We also use four bolts instead of two or three for added durability. For use with any 3.000" O.D. collector and 100% stainless steel.

DESCRIPTION	TUBE SIZE	PART#	PRICE
STUB KIT	2.500"	791-09025	\$129.99
STUB KIT	3.000"	791-09030	\$149.99

## STEPPED BAND CLAMPS

Smooth transition taper allows proper fit to seal expanded slip-fit connections. Great for muffler, tail pipe, and merge pipe connections.



DESCRIPTION	PART#	PRICE
BAND CLAMP FOR 2.500" JUNCTION	789-70250	\$34.99
BAND CLAMP FOR 2.750" JUNCTION	789-70275	\$34.99
BAND CLAMP FOR 3.000" JUNCTION	789-70300	\$34.99
BAND CLAMP FOR 3.500" JUNCTION	789-70350	\$34.99

Models for 2.500", 2.750", 3.000", or 3.500" pipe sizes. 1 clamp/ pkg.

## V-CLAMP KITS



Kit includes two weld-on v-clamp rings and stainless steel v-band clamp. Models for 2.500", 3.000", and 3.500" pipe sizes.

DESCRIPTION	PART#	PRICE
V-CLAMP COLLAR ASSEMBLY 2.500"	794-91225	\$49.99
V-CLAMP COLLAR ASSEMBLY 3.000"	794-91230	\$49.99
V-CLAMP COLLAR ASSEMBLY 3.500"	794-91235	\$59.99

## MANDREL BENT J-BENDS

Dynatech® stocks a complete inventory of mandrel bent J-bends. These are made from premium grade mild steel tubing.

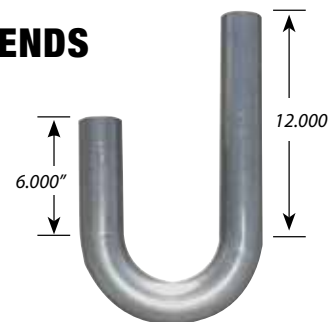

SIZE	CLR	STAINLESS PART#	PRICE
1.625"	2.625"	794-60302	\$29.99



**VISIT US ONLINE**

[www.DynatechHeaders.com](http://www.DynatechHeaders.com)

These products are intended for racing and off-road applications. Not legal for sale or use in the state of California, nor in states which have adopted California emission standards.



# ACCESSORIES

## FLANGES & GASKETS

### HIGH PERFORMANCE APPLICATIONS

A great exhaust system starts at the beginning - the flange. One of Dynatech's biggest advantages is our wide selection of port matched flanges. All of our flanges are CNC laser cut for unparalleled quality and fit.



**Stainless Steel Flanges**



**Stainless Steel Gasket**



	DESCRIPTION	FLANGE (single)	PORT	X	Y	THICKNESS	GASKET (pair)
	LS1	796-13000	1.750"	1.820"	1.820"	.375"	794-30001
	LS1	796-16061	1.875"	1.940"	1.940"	.375"	794-30001
	LS1	796-16062	2.000"	2.070"	2.070"	.375"	794-30006
	4.6 FORD	796-18061	1.750"	1.824"	1.824"	.375"	794-70001
	4 VALVE COBRA 4.6L	796-16071	1.875"	2.243"	1.465"	.375"	-
	6.1L HEMI	796-10661	1.875"	2.082"	1.508"	.375"	794-20002
	5.7L HEMI DRIVERS SIDE	796-10761	1.750"	1.820"	1.820"	.375"	794-10001
	5.7L HEMI PASS. SIDE	796-10762	1.750"	1.820"	1.820"	.375"	794-10001
	5.4L TRITON FORD 3 VALVE	796-18062	1.625"	1.696"	1.696"	.375"	794-70001
	5.4L FORD (PRE 2004)	796-19061	1.625"	1.696"	1.696"	.375"	794-90001
	5.0L FORD	796-17070	1.750"	1.815"	1.815"	.375"	794-70005
	5.0L FORD	796-17071	1.875"	1.940"	1.940"	.375"	794-70005
	5.3/6.2L CHEVY LT	796-13010	1.750"	1.980"	1.560"	.375"	794-30007
	5.3/6.2L CHEVY LT	796-13011	1.875"	2.100"	1.680"	.375"	794-30007
	5.3/6.2L CHEVY LT	796-13012	2.000"	2.216"	1.796"	.375"	794-30007

Starting at:  
**\$89<sup>99</sup>**

Starting at:  
**\$44<sup>99</sup>**

## LIMITED LIFETIME WARRANTY

the event the item cannot be repaired or replaced, a refund in the amount of the original purchase price may be issued. Proof of purchase is required for any / all warranty claims. Except for the limited lifetime warranty set forth herein, AFCO Performance Group, LLC makes no warranties either expressed or implied, written or oral, with regard to the products including, without limitation, any warranty of merchantability or fitness for a particular purpose. In no event shall AFCO Performance Group, LLC be liable for any special, incidental or consequential damages, or any other damages whatsoever arising out of or connected with the use or misuse of the products. Purchasers acknowledge and agree that no person, entity or agent of AFCO Performance Group, LLC has any authority to make any statement contrary to this disclaimer and that any warranty statements or representations allegedly made on behalf of AFCO Performance Group, LLC by any such person, entity or agent are void. AFCO Performance Group, LLC products are not D.O.T. approved and are intended for off-road use only. Purchasers are relying solely on their own skill and judgment to select, purchase and use suitable products and assume all responsibility and risk with regard thereto.

Catalytic Converters: Catalytic converters included with any SuperMAXX® system are limited to a 2 year limited replacement warranty. For any catalytic converter warranties, it is required that the product be returned to AFCO Performance Group, LLC for review. After inspection, a determination will be made as to what caused the failure. Any failure determined to be caused by an incorrect engine tune, or any other use for which the converter was not designed, will void the warranty. Any freight cost to get the product to AFCO Performance Group, LLC for evaluation will be the customer's responsibility.

Dynatech® SuperMAXX® Limited Lifetime Warranty: All Dynatech® SuperMAXX® exhaust systems come with a limited lifetime warranty. AFCO Performance Group, LLC will repair or replace any such products found after our inspection to be defective in workmanship or material, for the original purchasing customer, on the original installed vehicle. Any product that has been improperly installed, damaged, welded on or modified in any way will not be considered for warranty. In

These products are intended for racing and off-road applications. Not legal for sale or use in the state of California, nor in states which have adopted California emission standards.



# TRUCK / SUV

- Perfect, direct bolt-on fit.
- 0.375" Thick CNC laser-cut flanges.
- 3-Bolt ball-&-socket collector flanges.
- All flanges machine surfaced after welding.
- 3.000" Wide, 2-bolt band clamps.
- Optimized tube length for Hp and torque.
- 100% jig assembled and checked for an excellent fit.
- Triple layer stainless steel gaskets.
- T304 stainless steel construction.
- Detailed instructions & all hardware included.

## HOW TO PURCHASE YOUR DYNATECH® EXHAUST SYSTEM

### 1 HEADERS



### 2 INTERMEDIATE SECTION

The headers consist of a long tube set of headers with all of the required hardware included for the installation. The headers alone cannot be installed as a "Bolt In" to your factory catalytic converters and system.

The intermediate section consists of the required components to connect the headers to your factory or aftermarket "Cat-Back" exhaust system. In most cases, you have two choices when it comes to selecting your intermediate section. You can choose either the "Catted" or "Non Catted" version.

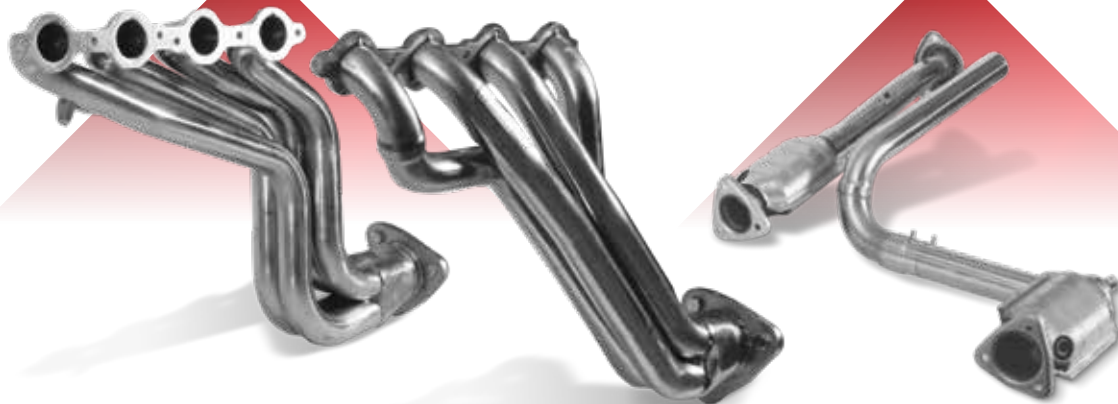

These products are intended for racing and off-road applications. Not legal for sale or use in the state of California, nor in states which have adopted California emission standards.

## FORD



APPLICATION	YEAR	ENGINE	HEADERS	CATTED	NON-CATTED	HP GAIN	INST. TIME	PAGE
F-150	'15-'17	5.0L	722-55210	722-54220	722-54230	30	5-7 hrs	47
F-150	'11-'14	5.0L	722-52210	722-52220	722-52230	31	5-7 hrs	48
F-150 2WD	'04 - '08	5.4L	722-62210	722-62320	-	14	4-6 hrs	49
F-150 4WD	'04 - '08	5.4L	722-62210	722-62220	722-62230	14	4-6 hrs	49
F-150 LIGHTNING EDITION	'99 - '04	5.4L	722-84210	722-84320	722-84330	20	4-6 hrs	50
F-150 2WD & 4WD	'99 - '03	5.4L	722-84210	722-84220	-	15	4-6 hrs	50

## GM



APPLICATION	YEAR	ENGINE	HEADERS	CATTED	NON-CATTED	HP GAIN	INST. TIME	PAGE
SILVERADO, AVALANCHE, TAHOE, YUKON, DENALI, ESCALADE	'14 - '19	5.3L & 6.2L	715-34110	715-34120	715-44120	32	4-6 hrs	51
	'07 - '13	6.2L	715-14110	715-14620	-	15	4-6 hrs	52
	'07 - '13	4.8, 5.3 & 6.0L	715-14110	715-14420	715-14430	15	4-6 hrs	52
	'99 - '06	6.0L	715-84110	715-84220	715-84230	15	4-6 hrs	53
	'99 - '06	4.8 - 5.3L	715-84110	715-84120	715-84130	25	4-6 hrs	53
H2 HUMMER	'07 - '09	6.0L	715-14110	715-14320	715-14330	25	4-6 hrs	54
H2 HUMMER	'00 - '06	6.0L	715-84110	715-84220	715-84230	25	4-6 hrs	54

## DODGE



APPLICATION	YEAR	ENGINE	HEADERS	CATTED	NON-CATTED	HP GAIN	INST. TIME	PAGE
DODGE RAM HEMI 2WD	'04 - '05	5.7L HEMI	724-84310	724-84520	-	17	4-6 hrs	55
DODGE RAM HEMI 4WD	'04 - '05	5.7L HEMI	724-84410	724-84620	-	17	4-6 hrs	55

These products are intended for racing and off-road applications. Not legal for sale or use in the state of California, nor in states which have adopted California emission standards.





**SUPERMAXX®**

# '15 - '17 FORD F-150

## STAINLESS STEEL HEADERS



INTERMEDIATE  
TUBES W/ CATS



INTERMEDIATE  
TUBES W/O CATS

### FEATURES

- PRIMARY TUBE SIZE:** 1.875"
- COLLECTOR SIZE:** 2.500"
- SYSTEM TUBE SIZE:** 2.500"
- MATERIAL:** T304 Stainless Steel
- TRANS:** Manual & Automatic
- INCLUDED:** Detailed instructions and all needed hardware.
- FIT:** Some cutting required for any factory or O.E. size aftermarket cat back.
- INSTALL TIME:** 5-7 hours

**+30 HORSEPOWER**  
**+47 FT-LBS TORQUE**

*Ceramic Coating Services  
are Available.  
Call Dynatech® for Details.*

**LIMITED LIFETIME WARRANTY**  
**MADE IN THE U.S.A.**

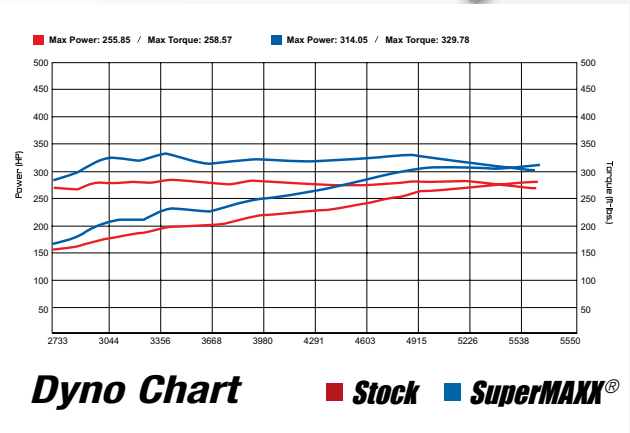

DESCRIPTION	PART #	PRICE
1.875" HEADERS	722-55210	\$999.99
INTERMEDIATE SECTION W/CATS	722-54220	\$699.99
INTERMEDIATE SECTION W/O CATS	722-54230	\$499.99

These products are intended for racing and off-road applications. Not legal for sale or use in the state of California, nor in states which have adopted California emission standards.





**SUPERMAXX**

# '11 - '14 FORD F-150

## STAINLESS STEEL HEADERS



INTERMEDIATE  
TUBES W/ CATS



INTERMEDIATE  
TUBES W/O CATS

### FEATURES

**PRIMARY TUBE SIZE:** 1.750" & 1.875"  
**COLLECTOR SIZE:** 2.500"  
**SYSTEM TUBE SIZE:** 2.500"  
**MATERIAL:** T304 Stainless  
**TRANS:** Manual & Automatic  
**INCLUDED:** Detailed instructions and all needed hardware.  
**FIT:** Some cutting required for any factory or O.E. size aftermarket cat back.  
**INSTALL TIME:** 5-7 hours

**+31 HORSEPOWER**  
**+27 FT-LBS TORQUE**

**LIMITED LIFETIME WARRANTY**  
**MADE IN THE U.S.A.**

*Ceramic Coating Services are Available.*  
 Call Dynatech® for Details.

DESCRIPTION	PART #	PRICE
1.750" HEADER SET	722-52210	\$999.99
1.875" HEADER SET	722-53210	\$999.99
CATTED SECTION	722-52220	\$699.99
NON-CATTED SECTION	722-52230	\$499.99

These products are intended for racing and off-road applications. Not legal for sale or use in the state of California, nor in states which have adopted California emission standards.



**SUPERMAXX**

# '04 - '08 FORD F-150

## STAINLESS STEEL HEADERS



INTERMEDIATE  
TUBES W/ CATS



INTERMEDIATE  
TUBES W/O CATS



### FEATURES

**PRIMARY TUBE SIZE:** 1.625"

**COLLECTOR SIZE:** 2.500"

**SYSTEM TUBE SIZE:** 2.500"

**MATERIAL:** T304 Stainless

**TRANS:** Manual & Automatic

**INCLUDED:** Detailed instructions and all needed hardware.

**FIT:** Direct Bolt-Up to any factory or O.E. size aftermarket cat back.

**INSTALL TIME:** 4-6 hours

**+14 HORSEPOWER**  
**+9 FT-LBS TORQUE**

**LIMITED LIFETIME WARRANTY**  
**MADE IN THE U.S.A.**

*Ceramic Coating Services are Available.*  
Call Dynatech® for Details.

DESCRIPTION	'04 - '08 2WD (5.4L)	'04 - '08 4WD (5.4L)	PRICE
HEADERS ONLY	722-62210	722-62210	\$999.99
INTERMEDIATE TUBES W/ CATS	722-62320	722-62220	\$649.99
INTERMEDIATE TUBES W/O CATS	.	722-62230	\$499.99

These products are intended for racing and off-road applications. Not legal for sale or use in the state of California, nor in states which have adopted California emission standards.

CONNECT WITH DYNATECH® [www.DynatechHeaders.com](http://www.DynatechHeaders.com) 800-848-5850



**SUPERMAXX®**

# '99 - '03 FORD F-150 '99 - '04 FORD LIGHTNING

## STAINLESS STEEL HEADERS



CAT BACK EXHAUST SYSTEM FOR LIGHTNING ONLY



### FEATURES

**PRIMARY TUBE SIZE:** 1.625"  
**COLLECTOR SIZE:** 2.500"  
**SYSTEM TUBE SIZE:** 2.500"  
**MATERIAL:** T304 Stainless  
**TRANS:** Manual & Automatic  
**INCLUDED:** Detailed instructions and all needed hardware.  
**FIT:** Direct Bolt-Up to any factory or O.E. size aftermarket cat back.  
**INSTALL TIME:** 4-6 hours

**+20 HORSEPOWER  
+14 FT-LBS TORQUE**

**LIMITED LIFETIME WARRANTY  
MADE IN THE U.S.A.**

*Ceramic Coating Services are Available.  
Call Dynatech® for Details.*



INTERMEDIATE TUBES W/ CATS FOR F-150



INTERMEDIATE TUBES W/ CATS FOR LIGHTNING



INTERMEDIATE TUBES W/O CATS FOR LIGHTNING

DESCRIPTION	'99 - '03 F-150 2WD/4WD (5.4L)	'99 - '04 LIGHTNING	PRICE
HEADERS ONLY	722-84210	722-84210	\$899.99
INTERMEDIATE TUBES W/ CATS	722-84220	722-84320	\$649.99
INTERMEDIATE TUBES W/O CATS	.	722-84330	\$499.99
CAT BACK SYSTEM: X-PIPE W/ DUAL 4.000" MUFFLERS	.	722-84231	\$749.99

These products are intended for racing and off-road applications. Not legal for sale or use in the state of California, nor in states which have adopted California emission standards.



**SUPERMAXX**

# '14 - '19 CHEVY/GMC 1500 TRUCK & SUV STAINLESS STEEL HEADERS

**NEW!**

**LIMITED LIFETIME WARRANTY  
MADE IN THE U.S.A.**



**+32 HORSEPOWER  
+43 FT-LBS TORQUE**

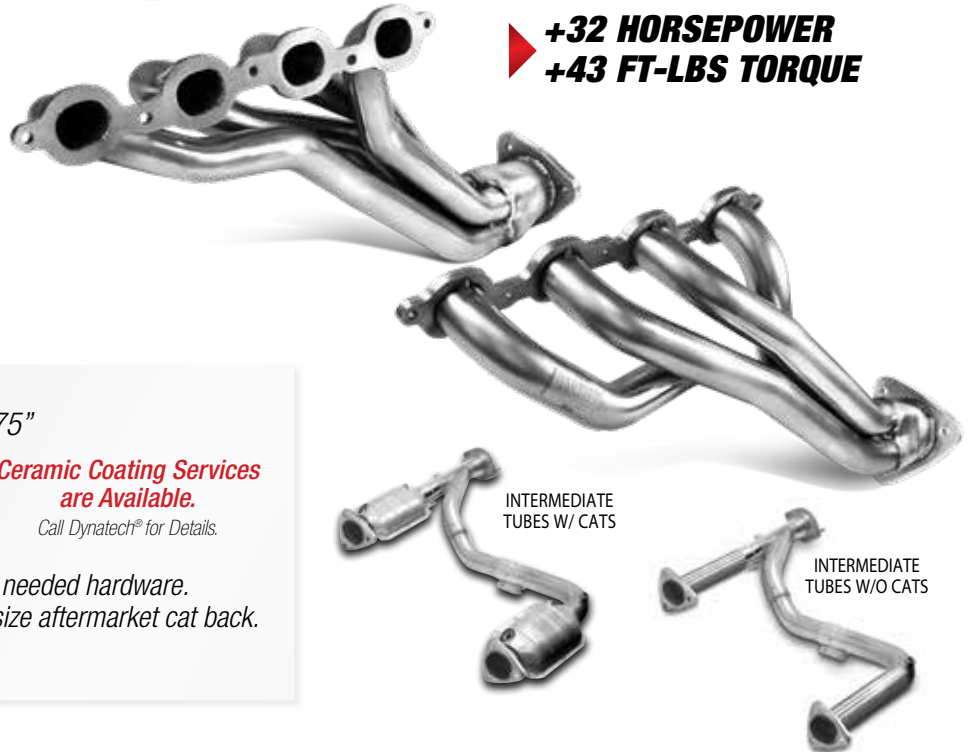

## FEATURES

- PRIMARY TUBE SIZE:** 1.750" or 1.875"
  - COLLECTOR SIZE:** 2.500"
  - SYSTEM TUBE SIZE:** 2.500"
  - MATERIAL:** T304 Stainless
  - TRANS:** Manual or Automatic
  - INCLUDED:** Detailed instructions and all needed hardware.
  - FIT:** Direct Bolt-up to any factory or O.E. size aftermarket cat back.
  - INSTALL TIME:** 4-6 hours
- Ceramic Coating Services  
are Available.*
- Call Dynatech® for Details.*

HEADER PRIMARY TUBE SIZE	PART #	ENGINE	PRICE
1.750"	715-34110	5.3L & 6.2L	\$999.99
1.875"	715-44110	5.3L & 6.2L	\$999.99
1.750" (2019 GM1500) <b>NEW!</b>	715-54110	5.3L	\$999.99
1.875" (2019 GM1500) <b>NEW!</b>	715-64110	5.3L	\$999.99

DESCRIPTION	PART #	ENGINE	CATS	PRICE
INTERMEDIATE TUBE SECTION	715-34120	5.3L	W/CATS	\$749.99
INTERMEDIATE TUBE SECTION	715-34130	5.3L	W/O CATS	\$599.99
INTERMEDIATE TUBE SECTION	715-44120	6.2L	W/ CATS	\$749.99
INTERMEDIATE TUBE SECTION	715-44130	6.2L	W/O CATS	\$599.99
INTERMEDIATE TUBE SECTION 2019 <b>NEW!</b>	715-54120	5.3L	W/ CATS	\$749.99
INTERMEDIATE TUBE SECTION 2019 <b>NEW!</b>	715-54130	5.3L	W/O CATS	\$599.99

These products are intended for racing and off-road applications. Not legal for sale or use in the state of California, nor in states which have adopted California emission standards.

CONNECT WITH DYNATECH® [www.DynatechHeaders.com](http://www.DynatechHeaders.com) 800-848-5850





**SUPERMAXX**

# '07 - '13 CHEVY 1500 TRUCK / SUV

## STAINLESS STEEL HEADERS



INTERMEDIATE TUBES W/ CATS



INTERMEDIATE TUBES W/O CATS

### FEATURES

**PRIMARY TUBE SIZE:** 1.750"  
**COLLECTOR SIZE:** 2.500"  
**SYSTEM TUBE SIZE:** 2.500"  
**MATERIAL:** T304 Stainless  
**TRANS:** Manual & Automatic  
**INCLUDED:** Detailed instructions and all needed hardware.  
**FIT:** Direct Bolt-Up to any factory or O.E. size aftermarket cat back.  
**INSTALL TIME:** 4-6 hours

*Ceramic Coating Services are Available.*

*Call Dynatech® for Details.*

**+15 HORSEPOWER**  
**+38.5 FT-LBS TORQUE**

**LIMITED LIFETIME WARRANTY**  
**MADE IN THE U.S.A.**

'07 - '13 (4.8L, 5.3L, & 6.0L) / DESCRIPTION	PART#	PRICE
HEADERS ONLY	715-14110	\$999.99
INTERMEDIATE TUBES W/ CATS ('07-'08)	715-14120	\$649.99
INTERMEDIATE TUBES W/O CATS ('07-'08)	715-14130	\$499.99
INTERMEDIATE TUBES W/ CATS ('09-'13)	715-14420	\$649.99
INTERMEDIATE TUBES W/O CATS ('09-'13)	715-14430	\$599.99

'07 - '13 (6.2L) / DESCRIPTION	PART#	PRICE
HEADERS ONLY	715-14110	\$999.99
INTERMEDIATE TUBES W/ CATS ('07-'10)	715-14220	\$599.99
INTERMEDIATE TUBES W/O CATS ('07-'10)	715-14230	\$499.99
INTERMEDIATE TUBES W/ CATS ('11-'13)	715-14620	\$599.99

These products are intended for racing and off-road applications. Not legal for sale or use in the state of California, nor in states which have adopted California emission standards.



**SUPERMAXX**

# '99-'06 CHEVY 1500 TRUCK / SUV

## STAINLESS STEEL HEADERS



### FEATURES

**PRIMARY TUBE SIZE:** 1.750"  
**COLLECTOR SIZE:** 2.500"  
**SYSTEM TUBE SIZE:** 2.500"  
**MATERIAL:** T304 Stainless  
**TRANS:** Manual & Automatic  
**INCLUDED:** Detailed instructions and all needed hardware.  
**FIT:** Direct Bolt-Up to any factory or O.E. size aftermarket cat back.  
**INSTALL TIME:** 4-6 hours

**+25 HORSEPOWER**  
**+15 FT-LBS TORQUE**

*Ceramic Coating Services are Available.*  
 Call Dynatech® for Details.

**LIMITED LIFETIME WARRANTY**  
**MADE IN THE U.S.A.**

DESCRIPTION	'99 - '06 CHEVY TRUCK (4.8L & 5.3L)	'99 - '06 CHEVY TRUCK (6.0L)	PRICE
HEADERS ONLY	715-84110	715-84110	\$899.99
INTERMEDIATE TUBES W/ CATS	715-84120	715-84220	\$649.99
INTERMEDIATE TUBES W/O CATS	715-84130	715-84230	\$499.99

These products are intended for racing and off-road applications. Not legal for sale or use in the state of California, nor in states which have adopted California emission standards.





**SUPERMAXX**

# '00 - '09 HUMMER H2

## STAINLESS STEEL HEADERS



### FEATURES

**PRIMARY TUBE SIZE:** 1.750"  
**COLLECTOR SIZE:** 2.500"  
**SYSTEM TUBE SIZE:** 2.500"  
**MATERIAL:** T304 Stainless  
**TRANS:** Manual & Automatic  
**INCLUDED:** Detailed instructions and all needed hardware.  
**FIT:** Direct Bolt-Up to any factory or O.E. size aftermarket cat back.  
**INSTALL TIME:** 4-6 hours

**+25 HORSEPOWER**  
**+15 FT-LBS TORQUE**

*Ceramic Coating Services are Available.*  
 Call Dynatech® for Details.

**LIMITED LIFETIME WARRANTY**  
**MADE IN THE U.S.A.**

DESCRIPTION	'00 - '06 HUMMER H2	'07 - '09 HUMMER H2	PRICE
HEADERS ONLY	715-84110	-	\$899.99
HEADERS ONLY	-	715-14110	\$999.99
INTERMEDIATE TUBES W/ CATS	715-84220	715-14320	\$649.99
INTERMEDIATE TUBES W/O CATS	715-84230	715-14330	\$499.99

These products are intended for racing and off-road applications. Not legal for sale or use in the state of California, nor in states which have adopted California emission standards.





**SUPERMAXX**

# '04 - '05 DODGE 1500 2WD/4WD

**STAINLESS STEEL HEADERS**

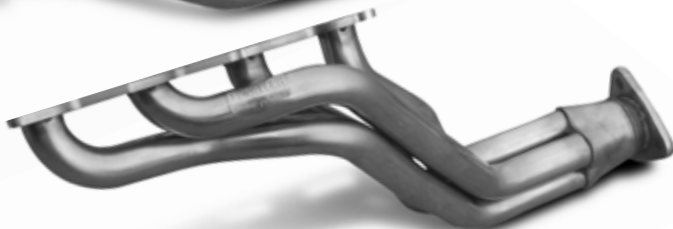

FIT 5.7L HEMI  
ENGINE ONLY

## FEATURES

**PRIMARY TUBE SIZE:** 1.750"

**COLLECTOR SIZE:** 2.500"

**SYSTEM TUBE SIZE:** 2.500"

**MATERIAL:** T304 Stainless

**TRANS:** Manual & Automatic

**INCLUDED:** Detailed instructions and all needed hardware.

**FIT:** Direct Bolt-Up to any factory or O.E. size aftermarket cat back.

**INSTALL TIME:** 4-6 hours

**+17 HORSEPOWER**  
**+15 FT-LBS TORQUE**

**LIMITED LIFETIME WARRANTY**  
**MADE IN THE U.S.A.**

*Ceramic Coating Services are Available.*

*Call Dynatech® for Details.*

DESCRIPTION	HEADERS (5.7L HEMI)	PRICE
2WD HEADERS ONLY	724-84310	\$899.99
4WD HEADERS ONLY	724-84410	\$899.99
2WD INTERMEDIATE TUBES W/ CATS	724-84520	\$599.99
4WD INTERMEDIATE TUBES W/ CATS	724-84620	\$599.99

These products are intended for racing and off-road applications. Not legal for sale or use in the state of California, nor in states which have adopted California emission standards.

CONNECT WITH DYNATECH® [www.DynatechHeaders.com](http://www.DynatechHeaders.com) 800-848-5850





# OVAL TRACK

**604  
CRATE**

## 604 CRATE ENGINES:

*604 Crate Engines have a unique cylinder head port design that, unlike the 602 Crate engines, has a much higher port ceiling. This requires a special flange to obtain maximum exhaust flow. Dynatech® has responded to these demands by offering a flange specifically designed for the 604 Crate Engines. This flange is currently offered on a number of our headers. If you find an application in our catalog that does not offer this unique flange on the header, please contact us and request it. We are always looking for more ways to satisfy our customers.*



## ONE YEAR LIMITED WARRANTY

AFCO Performance Group, LLC will repair or replace any products found upon our inspection to be defective in workmanship or material within 12 months from date of purchase for the original purchaser. Except for the limited warranty set forth herein, AFCO Performance Group, LLC makes no warranties either expressed or implied, written or oral, with regard to the products including, without limitation, any warranty of merchantability or fitness for a particular purpose. In no event shall AFCO Performance Group, LLC be liable for any special, incidental or consequential damages, or any other damages whatsoever arising out of or connected with the use or misuse of the products. Purchasers acknowledge and agree that no person, entity or agent of AFCO Performance Group, LLC has any authority to make any statement contrary to this disclaimer and that any warranty statements or representations allegedly made on behalf of AFCO Performance Group, LLC by any such person, entity or agent are void. AFCO Performance Group, LLC products are not D.O.T. approved or intended for street use. Purchasers are relying solely on their own skill and judgment to select, purchase and use suitable products and assume all responsibility and risk with regard thereto.



# OVAL TRACK EXHAUST



**1/2 SET CRASH REPLACEMENTS AVAILABLE**

**100%** JIG ASSEMBLED AND CHECKED FOR AN EXCELLENT FIT

**OPTIMIZED TUBE LENGTH** FOR MAXIMUM H.P. AND TORQUE

**17 GAUGE** STAINLESS & MILD STEEL CONSTRUCTION

ALWAYS CHECK YOUR SANCTIONING BODY'S RULE BOOK FOR COMPLIANCE BEFORE MAKING A PURCHASE.

**CNC LASER CUT FLANGES**



ALL FLANGES MACHINE SURFACED AFTER WELDING

**MADE IN THE U.S.A.**

**High Temperature Ceramic Coating**

Inside & Outside • Available Upon Request

## WHY SETTLE FOR LESS?

All Dynatech® header flanges are machine surfaced after final welding to prevent leakage.



**Dynatech**

OTHERS

## CRATE MODIFIED



## 2010-2014 SHAW CHASSIS

MADE IN THE U.S.A.

- Accommodates raising the engine 1.000".
  - High quality stainless steel for increased header life and exhaust velocity vs. mild steel.
  - Fully TIG-welded construction improves weld quality.
  - 9.000" long collector for IMCA rules.
  - Laser cut flanges w/ 604 crate port design.
  - Three inch collector outlet diameter.
  - Triple-step long tube design optimized on "in-house" engine dyno.
  - Gaskets and bolts included.
  - Accommodates raised & offset engine positions.
  - 1/2 sets are available for crash replacement.
  - Ceramic coating services are available.
- Call Dynatech® for details.
- 1 Year Limited Warranty.



DESCRIPTION	TUBE SIZE	COLL.	H.P.	PART #	PRICE
<b>604 CRATE - STAINLESS STEEL</b>	1.625"-1.750"-1.875"	3.000"	604 CRATE	<b>701-17310</b>	\$499.99

2010-2015 JET CHASSIS  
2015 KAZZBUILT CHASSIS

MADE IN THE U.S.A.

- Accommodates raising the engine 1.250".
  - High quality stainless steel for increased header life and exhaust velocity vs. mild steel.
  - Fully TIG-welded construction improves weld quality.
  - 9.000" long collector for IMCA rules.
  - Laser cut flanges w/ 604 crate port design.
  - Three inch collector outlet diameter.
  - Triple-step long tube design optimized on "in-house" engine dyno.
  - Gaskets and bolts included.
  - Accommodates raised & offset engine positions.
  - 1/2 sets are available for crash replacement.
  - Ceramic coating services are available.
- Call Dynatech® for details.
- 1 Year Limited Warranty.



DESCRIPTION	TUBE SIZE	COLL.	H.P.	PART #	PRICE
<b>604 CRATE - STAINLESS STEEL</b>	1.625"-1.750"-1.875"	3.000"	604 CRATE	<b>701-17410</b>	\$499.99



**DIRT WORKS • IMPRESSIVE • LIGHTNING  
• HOFFMAN • SHAW**

- Fits standard Chevy engines with angle or straight plug heads.
- Gaskets and bolts included.
- 1/2 sets available.
- Slip on collectors.
- Ceramic coating services are available. Call Dynatech® for details.
- 1 Year Limited Warranty.



**MADE IN THE U.S.A.**

DESCRIPTION	TUBE SIZE	COLL.	H.P.	INTERCHANGE #	PART #	PRICE
STANDARD CHEVY	1.750"	3.500"	300-450	172 & 172CM	701-19810	\$299.99

**DIRT WORKS • BMS • JET • SMILEY'S  
• PIERCE • HOFFMAN • VICTORY • LAZER**

- Fits angle or straight plug heads.
- Gaskets and bolts included.
- Longer primaries for maximum torque and horsepower.
- 1/2 sets available.
- Ceramic coating services are available. Call Dynatech® for details.
- 1 Year Limited Warranty.



**MADE IN THE U.S.A.**

DESCRIPTION	TUBE SIZE	COLL.	H.P.	INTERCHANGE #	PART #	PRICE
STANDARD CHEVY	1.750" - 1.875"	3.500"	450+	1186V	701-10610	\$299.99

**2010-2014 SHAW CHASSIS**

- Accommodates raising the engine 1.000".
- 9.000" long collector for IMCA rules.
- 3.000" inch collector outlet diameter.
- 1-5/8" Straight through design for crate motors and classes that require 1-5/8" tubes.
- Gaskets and bolts included.
- Accommodates raised & offset engine positions.
- 1/2 sets are available for crash replacement.
- Ceramic coating services are available. Call Dynatech® for details.
- 1 Year Limited Warranty.



**MADE IN THE U.S.A.**

DESCRIPTION	TUBE SIZE	COLL.	H.P.	INTERCHANGE #	PART #	PRICE
SPORT/ B MOD	1.625"	3.000"	300-400	1185V	701-17610	\$299.99

# CRATE DIRT LATE MODEL

**BARRY WRIGHT • MORRIS • ROCKET • SWARTZ**  
 • OTHERS W/ 2.625" OFFSET & 6.000" SETBACK



**MADE IN THE U.S.A.**

- Unique flange design fits standard Chevy and 602 Crate heads with a single part number.
- 604 Crate available in port matched mild steel or Stainless Steel.
- Increase Torque with Extension Kits and Torque Boosters sold in kits. (see p.69)
- Machine surfaced flanges – no leaks.
- 1/2 sets available.
- 1 year limited warranty.



DESCRIPTION	TUBE SIZE	COLL.	PART #	PRICE
<b>604 CRATE - STAINLESS STEEL ULTIMATE TORQUE PACKAGE**</b>	1.625"-1.750"	3.000"	<b>711-65810</b>	\$999.99
<b>604 CRATE - STAINLESS STEEL HEADERS / EXTENSION KIT*</b>	1.625"-1.750"	3.000"	<b>711-55810</b>	\$699.99
<b>604 CRATE - STAINLESS STEEL HEADERS</b>	1.625"-1.750"	3.000"	<b>711-45810</b>	\$599.99

\*\*Includes Headers, Extension Kit, and Torque Boosters  
 \*Includes Headers, 80° Elbow & 14.000" Extension Pipe.

**FAST • GRT • SHAW • TRAKSTAR**  
 • OTHERS W/ 0.625" OFFSET & 6.000" SETBACK



**MADE IN THE U.S.A.**

- Unique flange design fits standard Chevy and 602 Crate heads with a single part number.
- 604 Crate available in port matched mild steel or Stainless Steel.
- Increase Torque with Extension Kits and Torque Boosters sold in kits. (see p.69)
- Machine surfaced flanges – no leaks.
- 1/2 sets available.
- 1 year limited warranty.



DESCRIPTION	TUBE SIZE	COLL.	PART #	PRICE
<b>604 CRATE - STAINLESS STEEL ULTIMATE TORQUE PACKAGE**</b>	1.625"-1.750"	3.000"	<b>711-66410</b>	\$999.99
<b>604 CRATE - STAINLESS HEADER / EXTENSION KIT*</b>	1.625"-1.750"	3.000"	<b>711-56410</b>	\$699.99
<b>604 CRATE - STAINLESS HEADER</b>	1.625"-1.750"	3.000"	<b>711-46410</b>	\$574.99

\*\*Includes Headers, Extension Kit, and Torque Boosters  
 \*Includes Headers, 80° Elbow & 14.000" Extension Pipe.

# CRATE DIRT LATE MODEL

**BERNHEISEL • LAZER • MASTERSBILT**  
**• RAYBURN • WARRIOR**

**MADE IN THE U.S.A.**

- Unique flange design fits standard Chevy and 602 Crate heads with a single part number.
- 604 Crate available in port matched mild steel or Stainless Steel.
- Increase Torque with Extension Kits and Torque Boosters sold in kits below.
- Machine surfaced flanges – no leaks.
- 1/2 sets available.
- 1 year limited warranty.



DESCRIPTION	TUBE SIZE	COLL.	PART #	PRICE
<b>604 CRATE - STAINLESS STEEL ULTIMATE TORQUE PACKAGE**</b>	1.625"-1.750"	3.000"	<b>711-65910</b>	\$999.99
<b>604 CRATE - STAINLESS STEEL HEADERS / EXTENSION KIT*</b>	1.625"-1.750"	3.000"	<b>711-55910</b>	\$689.99
<b>604 CRATE - STAINLESS HEADER</b>	1.625"-1.750"	3.000"	<b>711-45910</b>	\$574.99

\*Includes Headers, 80° Elbow & 14.000" Extension Pipe.

\*\*Includes Headers, Extension Kit, and Torque Boosters.

## COLLECTOR EXTENSIONS

### 14" EXTENSIONS



- Designed for use with crate engines.
- Equalizes crate engine exhaust system when used with 80° elbow.



### 80° ELBOW EXTENSION

- Designed for use on driver's side dirt late model headers.
- Used to route exhaust toward rear of car.

— PURCHASE 604 CRATE ACCESSORIES INDIVIDUALLY —

APPLICATION	PART #	PRICE	APPLICATION	PART #	PRICE
14.000" EXTENSION	<b>780-00314</b>	\$29.99	80° ELBOW	<b>780-80301</b>	\$29.99
14.000" STAINLESS EXTENSION	<b>780-01314</b>	\$59.99	80° ELBOW STAINLESS STEEL	<b>780-80311</b>	\$69.99

## TORQUE BOOSTERS

The Dynatech® Torque Booster is a great way to pick up some low end torque on many engines. The gains are usually between 2500 and 4200 rpm, which is an excellent benefit for restarts. This device is a simple way to quickly add that well needed torque on the low end without sacrificing any power on the top end.



- Easy install.
- Excellent add-on for crate engines.
- Increased torque on restarts.
- Promotes torque gains of 10% or more.

APPLICATION	INLET SIZE	OUTLET SIZE	PART #	PRICE
TORQUE BOOSTER (602 & 604 CRATE)	3.000"	3.000"	<b>772-06312</b>	\$99.99
TORQUE BOOSTER (500-600 HP Engines)	3.000"	3.500"	<b>772-06302</b>	\$99.99
TORQUE BOOSTER (600+ HP Engines)	3.500"	3.500"	<b>772-06352</b>	\$99.99
TORQUE BOOSTER STAINLESS STEEL (604)	3.000"	3.000"	<b>772-06322</b>	\$149.99

# DYNATECH®

▶ DYNATECH T-SHIRT **\$14<sup>99</sup>**  
89118



▶ STRETCH FIT HAT **\$24<sup>99</sup>**  
89045

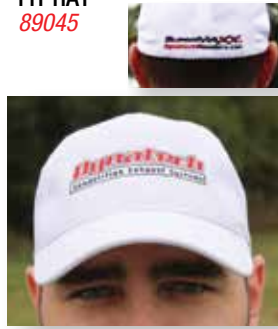

▶ DYNATECH COOLIE **\$2<sup>99</sup>**  
89098



▶ 8' x 3' BANNER **\$21<sup>99</sup>**  
BANNER



# AFCO

▶ AT SERIES T-SHIRT **\$14<sup>99</sup>**  
89108



▶ AT SERIES HOODIE **\$29<sup>99</sup>**  
89115



▶ AFCO WORK SHIRT **\$34<sup>99</sup>**  
89086



▶ AFCO WORK JACKET **\$69<sup>99</sup>**  
89095



▶ AFCO BANNER **\$19<sup>99</sup>**  
LIT-215



# LONGACRE®

▶ BLACK TWILL HAT **\$19<sup>99</sup>**  
52-11655



▶ LONGACRE® PIT GEAR BAG **\$39<sup>99</sup>**  
52-11911



▶ LONGACRE® PIT GLOVES **\$24<sup>99</sup>**  
52-11208





# AFCO

PERFORMANCE GROUP

Visit [www.AFCOPERFORMANCEGROUP.com](http://www.AFCOPERFORMANCEGROUP.com) to view all of our brands and download or request our catalogs!

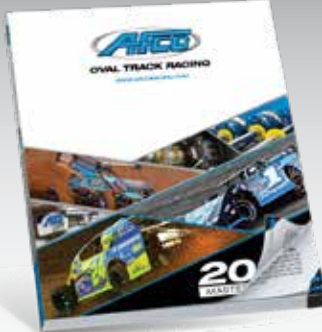

AFCO Oval Track Racing



AFCO Drag Racing, Muscle, Street Rod, High Performance



Dynatech® Headers



PRO Shocks



Longacre® Racing Products



DeWitts Radiator

## CONTACT INFO

### MAILING ADDRESS

P.O. Box 548  
Boonville, IN 47601

### SALES AND TECHNICAL SUPPORT

800-632-2320  
Open Daily Monday-Friday  
8 a.m. - 5:00 p.m. CST

### PHYSICAL ADDRESS

977 Hyrock Blvd.  
Boonville, IN 47601

### MARKETING PARTNERS



### LIMITED WARRANTY

AFCO Performance Group, LLC will repair or replace any products found upon our inspection to be defective in workmanship or material within 12 months from date of purchase for the original purchaser. Except for the limited warranty set forth herein, AFCO Performance Group, LLC makes no warranties either expressed or implied, written or oral, with regard to the products including, without limitation, any warranty of merchantability or fitness for a particular purpose. In no event shall AFCO Performance Group, LLC be liable for any special, incidental or consequential damages, or any other damages whatsoever arising out of or connected with the use or misuse of the products. Purchasers acknowledge and agree that no person, entity or agent of AFCO Performance Group, LLC has any authority to make any statement contrary to this disclaimer and that any warranty statements or representations allegedly made on behalf of AFCO Performance Group, LLC by any such person, entity or agent are void. AFCO Performance Group, LLC products are not D.O.T. approved or intended for street use. Purchasers are relying solely on their own skill and judgment to select, purchase and use suitable products and assume all responsibility and risk with regard thereto.

© Copyright 2020 AFCO Performance Group • Printed in the U.S.A.

This catalog may not, in whole or in part, be copied, photocopied, reproduced, or converted to any electronic or machine-readable form without written consent of AFCO Performance Group.

# UltimateM.com

Visit us today to order a complete car and purchase parts for all your quarter midget needs!

# **Dynatech**<sup>®</sup>

Competition Exhaust Systems

[WWW.DYNATECHHEADERS.COM](http://WWW.DYNATECHHEADERS.COM)

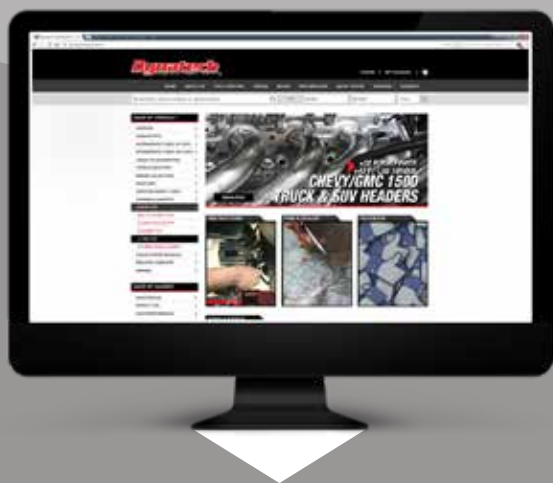

**Visit us online at [DynatechHeaders.com](http://DynatechHeaders.com) for more great products from Dynatech!**

Dynatech continues to be the exhaust leader in all forms of racing and high performance applications. Advances in engineering, design and performance help keep Dynatech products at the forefront of innovation, quality and performance.



**Follow us on Facebook to keep up with the action and all things Dynatech related!**

For the latest news from Dynatech on new product development information, install videos, technical manuals, technical tips and event schedules, find us online at [Facebook.com/DynatechHeaders](http://Facebook.com/DynatechHeaders).

## **Dynatech Exhaust Products**

- ▶ 977 Hyrock Blvd., Boonville, IN 47601
- ▶ Ph: 800.848.5850 Fax: 800.319.2551

Distributed by:

**WINNING**  
PROMOTIONS

P.O. Box 548, Boonville, IN 47601