

NOT FOR USE ON AIRBAG EQUIPPED VEHICLES

CLASSIC/CHALLENGER WHEELS ONLY

IF YOU HAVE A PAINTED SPOKE, YOUR WHEEL CAME WITH A SILVER FOIL DISC THAT MUST BE USED FOR PROPER HORN OPERATION. REFER TO INSTRUCTION SHEET WITH WHEEL

DO NOT THROW AWAY!

SHOWN: TYPICAL CLASSIC/CHALLENGER INSTALLATION
SEE INSTRUCTION SHEET PROVIDED WITH WHEEL FOR SIGNATURE SERIES HORN HOOKUP

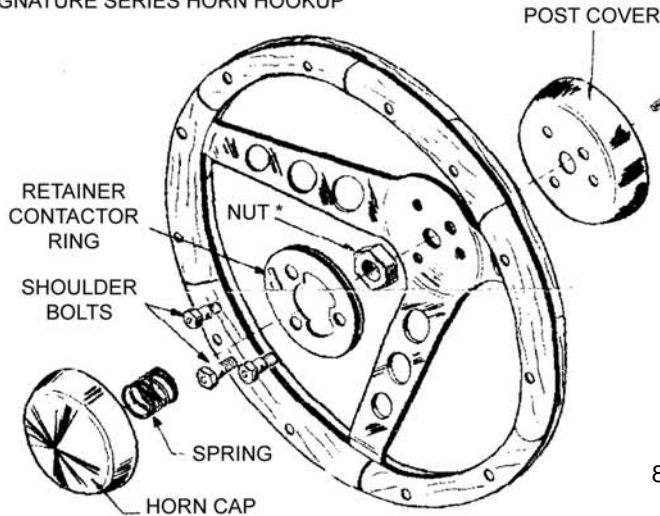

GRANT

FORM #3

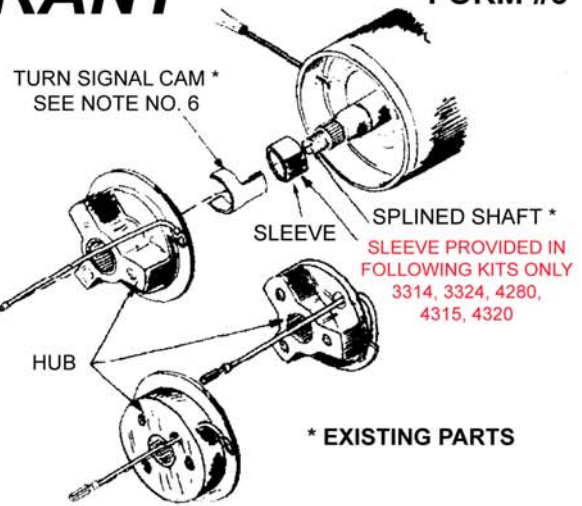

Apply grease from enclosed capsules to cover the copper contact surface on custom hub. This will reduce wear on the parts and does not interfere with the electrical circuit.

8. Position custom hub onto splined shaft observing that "top" is located in accordance with the mark you made in step No. 4.
9. Position post cover, if provided, and wheel onto hub using the three shoulder bolts provided, but do not tighten them.
10. Check to see if wheel is in the proper position and if correct install the wheel retainer nut and tighten securely.

Remove shoulder bolts and reinstall the same through retainer contactor ring so that the **fiber side is toward you**. Tighten shoulder bolts and connect wire lead from hub to terminal on retainer contactor ring.

When tightening the shoulder bolts please keep in mind that excessive torque will result in damage to the hub. The wheel retainer nut, if properly tightened, will firmly hold hub/wheel assembly onto vehicle.

11. Position spring on nut. (You may find tape a help). Place horn cap in position by aligning dimples in cap with reliefs in fiber material and push until dimples pass fiber. Turn cap left or right until tight (about 1/4"-1/2").
12. Reconnect battery or replace fuse and enjoy your new wheel.

TORQUE REQUIREMENTS

SHOULDER BOLTS 10-12 FT/LBS
STEERING SHAFT NUT 25-30 FT/LBS

ATTN: TOYOTA (HUB NO. 10179) AND HONDA/ACURA VEHICLES (HUB NO. 10069). THESE HUBS ARE DESIGNED TO FIT ONTO THE SHAFT VERY TIGHTLY AND BE DRAWN DOWN BY TIGHTENING THE SHAFT NUT.

1. Point wheels straight ahead and disconnect battery or pull horn fuse before starting removal of the old wheel so horn won't short out and blow during installation.
2. Remove horn mechanism. This is normally done by one or more of the following steps:
 - a.) Press down on horn cap or ring and turn.
 - b.) Remove emblem cap from its snapped-in condition by grasping it and pulling toward you or pry loose.
 - c.) Horn ring and emblem may be secured by screws, which are concealed in rear side of wheel spokes.

If one of the above operations has not removed all of the horn parts, it will have exposed the remaining screws to permit easy removal of the balance of such parts.

3. Remove nut holding wheel to shaft.
4. Mark shaft as to which is the top of the wheel.
5. With conventional puller, (or GRANT puller 5891), use the two tapped holes which you will find in the hub of old wheel to pull off the steering shaft.

If a puller is not available, you may improvise an efficient one to do the job. By drilling two holes of the proper size in a short steel bar and using two screws of the proper length, you can tighten them and pull the old wheel very easily.

6. If custom hub does not have provisions for turn signal cancellation, remove the turn indicator cam from the back of your old steering wheel and reinstall it in the same position on back of hub. Generally this part is affixed to the steering wheel with screws, or clamped on by spring tension. **NOTE: Some cams are molded into the old wheel and are not removable, use the roll pin(s) provided in kit for these applications. See enclosed instructions.**

7. **On vehicles using kit Nos. 3314, 3324, 4280, 4315, 4320 install small tubular metal sleeve over splined shaft.**

Our Limited Warranty

We warrant this product for ninety (90) days from the date of original purchase to be free from defects in materials and workmanship. If, during this period, the product fails under normal usage because of a manufacturing defect, then we will replace or repair the item. To obtain repair or replacement under the terms of this warranty, notify us at 615 Elca Lane, Suite C, Brownsville, TX 78521. Proof of purchase and date of purchase are required to validate warranty.

All implied warranties, including warranty of merchantability, are limited to this same ninety-day period from date of original purchase. We are not liable for any direct or consequential loss or property damage arising from any use of this product. This warranty gives you specific legal rights, and you may also have other rights which vary from state to state. Offer good in U.S.A. and Canada only.

IMPORTANT

FOR YOUR OWN SAFETY, DO **NOT** USE THIS WHEEL FOR ANY COMPETITIVE OR COMMERCIAL RACING PURPOSES: RACING DOES NOT CONSTITUTE NORMAL USAGE AND THEREFORE MAKES THIS WARRANTY VOID.

On the Web: www.grantproducts.com

Rev. 4/09 by J.F.

97502-00-01

INSTRUCTION SUPPLEMENT

READ BEFORE ASSEMBLING WHEEL

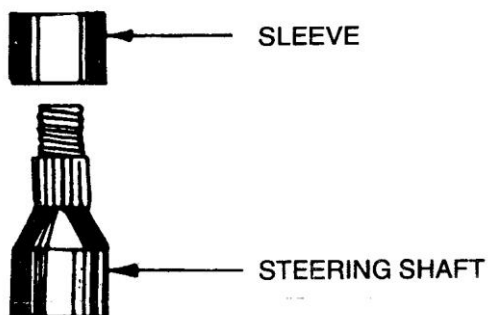

AFTER THE EXISTING STEERING WHEEL AND ASSOCIATED HARDWARE HAVE BEEN REMOVED AS INDICATED IN YOUR INSTRUCTION SHEET PLACE SLEEVE OVER STEERING SHAFT AS SHOWN ABOVE.

IMPORTANT NOTE

SLEEVE SHOULD FIT **FREELY** OVER SHAFT AND SLIDE DOWN UNTIL IT BOTTOMS.

ON SOME MODELS THE PLASTIC TURN SIGNAL CANCELING MECHANISM PREVENTS THIS SLEEVE FROM BOTTOMING OR FITS SNUGLY AGAINST THE SIDES OF SLEEVE. IF EITHER OF THESE CONDITIONS EXIST, **DO NOT USE SLEEVE**, IT IS NOT REQUIRED.

CONTINUE WITH INSTRUCTIONS FOUND WITH KIT AND WHEEL.